

Op Amp Common-Mode Rejection Ratio (CMRR)

COMMON-MODE REJECTION RATIO (CMRR)

If a signal is applied equally to both inputs of an op amp, so that the differential input voltage is unaffected, the output should not be affected. In practice, changes in common mode voltage will produce changes in output. The op amp *common-mode rejection ratio* (CMRR) is the ratio of the common-mode gain to differential-mode gain. For example, if a differential input change of Y volts produces a change of 1 V at the output, and a common-mode change of X volts produces a similar change of 1 V, then the CMRR is X/Y. When the common-mode rejection ratio is expressed in dB, it is generally referred to as common-mode rejection (CMR)—*please note that there is very little consistency in this throughout the semiconductor industry with regards to the use of dB or ratio values for CMR or CMRR.*

Typical low frequency CMR values can be between 70 dB and 120 dB, but at higher frequencies, CMR deteriorates. In addition to a CMRR numeric specification, many op amp data sheets show a plot of CMR versus frequency, as shown in Figure 1 for the [OP177](#) precision op amp.

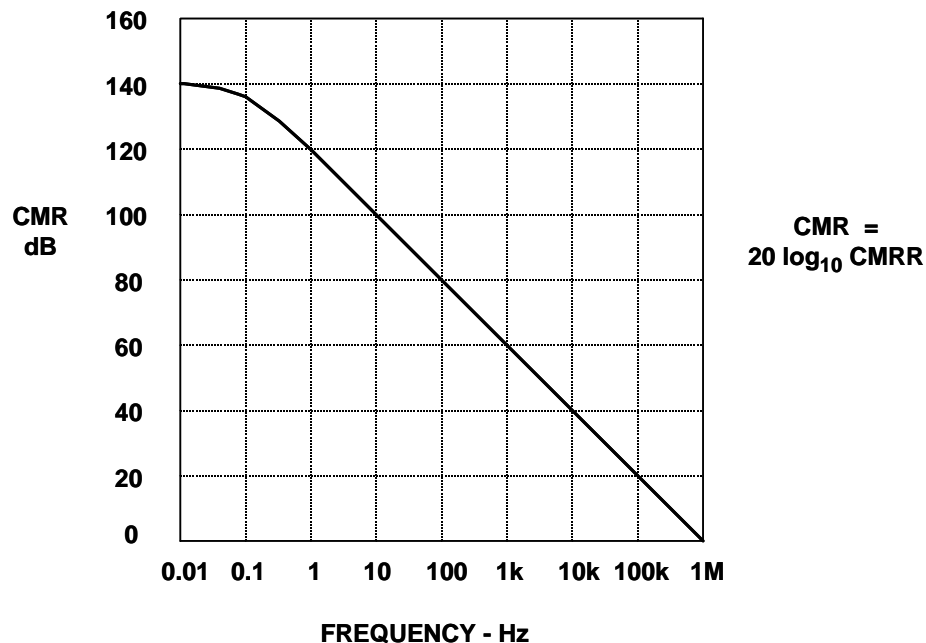

Figure 1: CMRR for the OP177

CMRR produces a corresponding output offset voltage error in op amps configured in the non-inverting mode as shown in Figure 2. Note inverting mode operating op amps will have less CMRR error. Since both inputs are held at a ground (or virtual ground), there is no CM dynamic voltage.

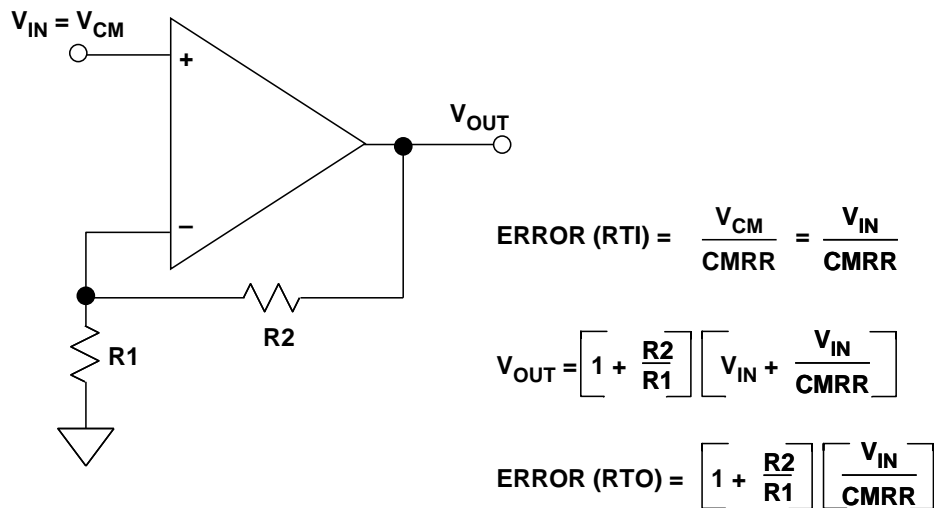

Figure 2: Calculating Offset Error Due to Common-Mode Rejection Ratio (CMRR)

MEASURING COMMON MODE REJECTION RATIO

Common-mode rejection ratio can be measured in several ways. The method shown in Figure 3 below uses four precision resistors to configure the op amp as a differential amplifier, a signal is applied to both inputs, and the change in output is measured—an amplifier with infinite CMRR would have no change in output. The disadvantage inherent in this circuit is that the ratio match of the resistors is as important as the CMRR of the op amp. A mismatch of 0.1% between resistor pairs will result in a CMR of only 66 dB—no matter how good the op amp! Since most op amps have a low frequency CMR of between 80 dB and 120 dB, it is clear that this circuit is only marginally useful for measuring CMRR (although it does an excellent job in measuring the matching of the resistors!).

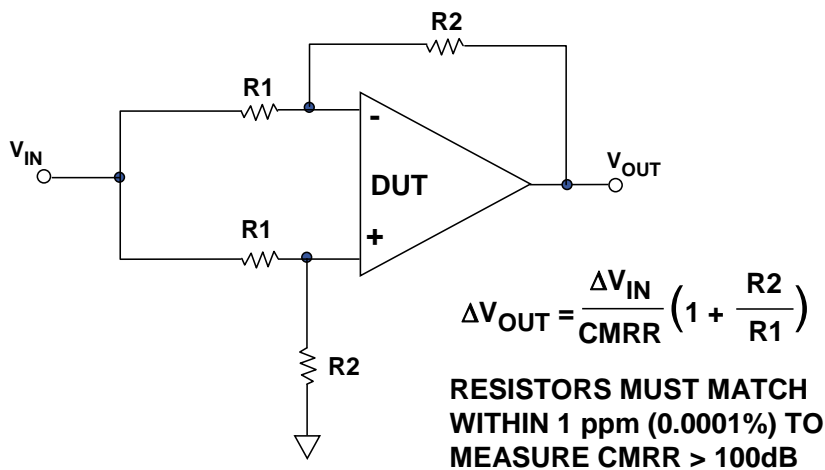

Figure 3: Simple Common-Mode Rejection Ratio (CMRR) Test Circuit

The slightly more complex circuit shown in Figure 4 below measures CMRR without requiring accurately matched resistors. In this circuit, the common-mode voltage is changed by switching the power supply voltages. (This is easy to implement in a test facility, and the same circuit with different supply voltage connections can be used to measure power supply rejection ratio).

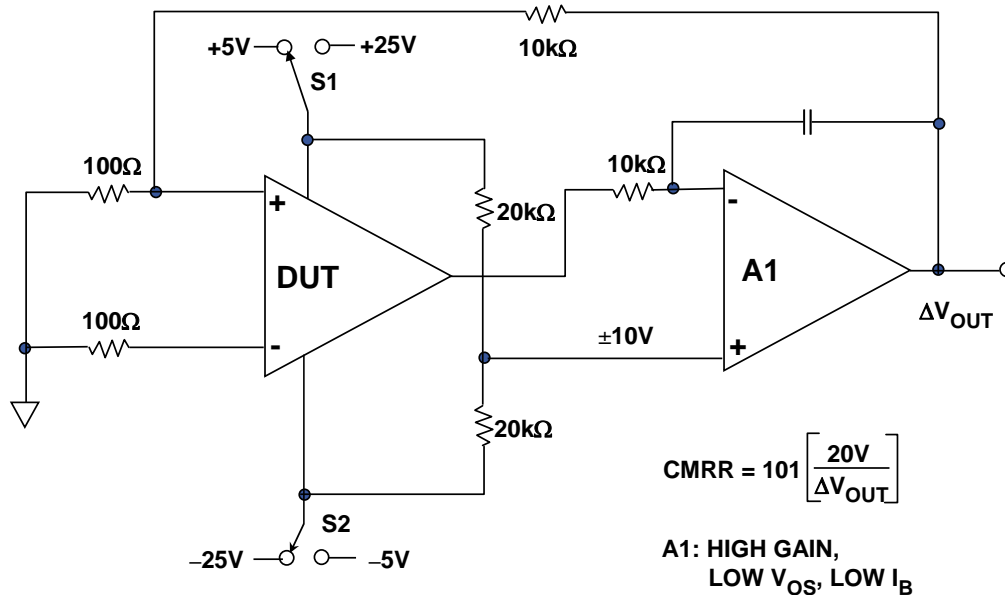

Figure 4: CMRR Test Circuit Does Not Require Precision Resistors

The power supply values shown in the circuit are for a ± 15 V DUT op amp, with a common-mode voltage range of ± 10 V. Other supplies and common-mode ranges can also be accommodated by changing voltages, as appropriate. The integrating amplifier A1 should have high gain, low V_{OS} and low I_{B} , such as an [OP97](#) family device.

REFERENCES:

1. Hank Zumbahlen, *Basic Linear Design*, Analog Devices, 2006, ISBN: 0-915550-28-1. Also available as [Linear Circuit Design Handbook](#), Elsevier-Newnes, 2008, ISBN-10: 0750687037, ISBN-13: 978-0750687034. Chapter 1.
2. Walter G. Jung, *Op Amp Applications*, Analog Devices, 2002, ISBN 0-916550-26-5, Also available as [Op Amp Applications Handbook](#), Elsevier/Newnes, 2005, ISBN 0-7506-7844-5. Chapter 1.

Copyright 2009, Analog Devices, Inc. All rights reserved. Analog Devices assumes no responsibility for customer product design or the use or application of customers' products or for any infringements of patents or rights of others which may result from Analog Devices assistance. All trademarks and logos are property of their respective holders. Information furnished by Analog Devices applications and development tools engineers is believed to be accurate and reliable, however no responsibility is assumed by Analog Devices regarding technical accuracy and topicality of the content provided in Analog Devices Tutorials.