

## Amplifier Classes

by Hank Zumbahlen,  
Analog Devices, Inc.

### IN THIS MINI TUTORIAL

*Operational amplifiers (op amps) are differentiated by the class of the output stage. This mini tutorial is one in a series of tutorials on discrete circuits.*

One of the ways that amplifiers are differentiated is by the class of its output stage. This classification is determined by what percentage of the output cycle the output device conducts. The basic tradeoff is distortion vs. power.

The basic classifications are classes A, B, C, and D. Class D is not discussed in detail in this tutorial, since it is a completely different beast (a separate mini tutorial will be developed on Class D amplifiers). A Class D amplifier operates as a switch mode circuit. The output devices are either saturated (turned on) or cutoff (turned off). This is similar in concept to a switch mode power supply.

There are some amplifiers built using Class D outputs. Class D amplifiers are very efficient. This is particularly attractive where significant output current must be delivered and there is concern about the dissipation in the chip. An example of this is the speaker driver in many consumer applications. Class D is also attractive in battery-powered circuits since there is little dissipation in the output drivers themselves and most of the current is delivered to the load. In fact, that is their main attribute. A major drawback with Class D is the spurious high frequency radiation that must be dealt with.

There are some other classifications that one may run into, but these are rather rare. They often have to do with minimizing dissipation by varying the power supply level in some way. This tutorial does not cover these types.

The Class C amplifier sometime finds application in RF circuits, but for the most part it is not used in op amp circuits. Therefore, that leaves Class A and Class B.

The simplest configuration is Class A. In this class, the output device is biased so that it conducts for the entire cycle of the output waveform. This has the potential for the least amount of distortion. However, the disadvantage is the power dissipation in the output devices. A Class A amplifier draws a constant power from the power supply. What power is not delivered to the load is dissipated in the output devices.

The basic Class A output is shown in Figure 1. The upper device (Q1) is the output driver. It conducts over the entire output cycle. The lower device (Q2) is simply a constant current load. The idle current is set so that it is greater than the currents expected to be delivered to the load ( $R_{LOAD}$ )

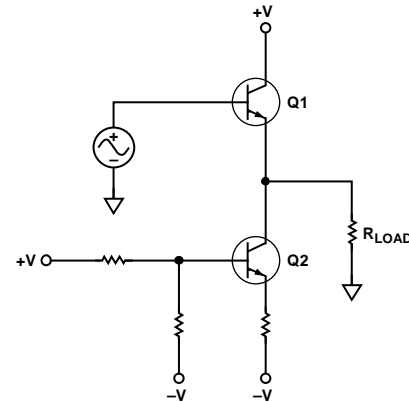

Figure 1. Class A Output Stage

Looking at the load line of a Class A amplifier (see Figure 2), note that the bias point is set so that the output device conducts over the full cycle.

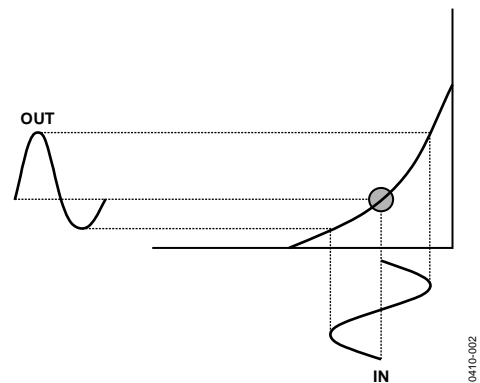

Figure 2. Class A Load Line

In a Class B output stage, the output devices are biased so that each device conducts over half the cycle. This means that this configuration is, by necessity, a push-pull configuration. This has the advantage of much lower dissipation in the output devices. Only the current delivered to the load is passed through the output devices. This makes the Class B output much more desirable in a monolithic op amp. The heat generated in the output causes drift in the input stage.

Figure 3 shows that the Class B output stage. Q1 conducts over the positive portion of the cycle and Q2 conducts over the negative portion of the cycle. The diodes compensate for the  $V_{BE}$  drop of the output devices.

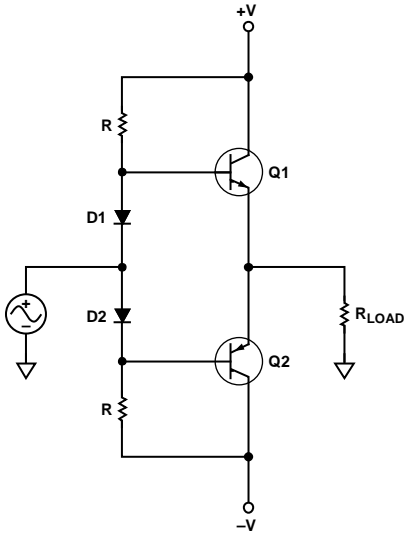

Figure 3. Class B Output Stage

The load line of a Class B amplifier is shown in Figure 4. Note that the bias point is low on the load line, showing that the device (the upper device in this case) is close to cutoff.

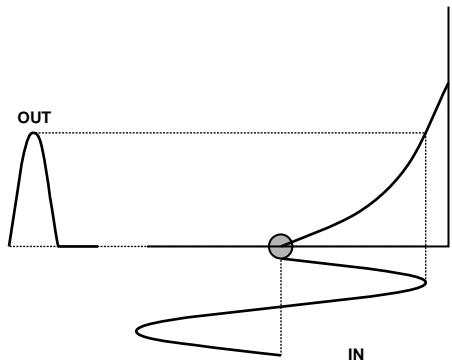

Figure 4. Class B Load Line

The biggest problem with Class B output is a small portion of the output around the center where neither device conducts. This gives rise to a phenomenon called crossover notch. This is a big problem, especially in audio applications, since the point of maximum distortion occurs at the point of minimum signal. Crossover distortion is illustrated in Figure 5.

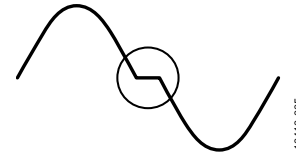

Figure 5. Crossover Distortion

The issue of crossover notch can be compensated for by biasing the output stage more into the linear range. This causes both devices to conduct over a part of the output cycle. Referring to Figure 6, the diodes in the Class B output stage are replaced by voltage sources. Increasing the voltage on these sources causes their respective devices to conduct over more of the output cycle. This reduces crossover notch. The tradeoff is that dissipation of the output stage increases.

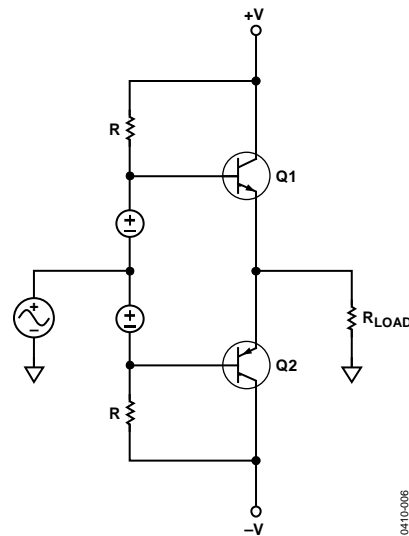

Figure 6. Class AB Output

