

Compact, configurable and customizable reference design for battery-operated brushless power tools based on STM32G431 and STDRIVE101



Features

- Input voltage from 12 to 24 V dc (Input voltage customizable to 36V with change in resistors, up to 8S batteries)
- Output RMS current up to 20 AMP
- The board comprises the following key devices:
 - **STM32G431RB**: A high-performance Arm®-based Cortex®-M4 32-bit MCU+FPU with integrated op amps and comparators in LQFP 64 (10x10mm) package
 - **STDRIVE101**: Triple half-bridge high-voltage gate driver in VFQFPN 4x4 with inbuilt regulator and protection features
 - **STL220N6F7**: Six N-channel 60 V, 0.014 Ω typ., 120 A, STripFET F7 power MOSFET in a PowerFLAT 5x6 package
 - **L6981**: 1.5 A synchronous step-down converter in a PowerSO-8 package
 - **LDL112**: 1.2A low quiescent current LDO with reverse current protection in a SO8-batwing package
 - **ESDALC6V1-1U2**: Single line low capacitance Transil™ for ESD protection is a precision 500 mA regulator in DPAK package
 - **TSV911A**: Single, dual, and quad rail to rail input/output 8MHz op-amp
 - **TS861**: Rail to rail micropower Bi-CMOS comparators
 - **BAT54**: Small signal Schottky diodes
 - **BAT30F4**: 30V Schottky barrier diodes in a 0201 package
- Hardware features enabling efficient motor control options
 - Sensor less three-shunt vector (FOC) algorithm (default)
 - Single-shunt vector (FOC) algorithm
 - Digital hall sensors input
 - Back EMF sensing
 - Bus voltage sensing
 - Sensored or sensorless 6 step algorithm
- Empowered with feature rich STM32 motor control ecosystem for permanent magnet synchronous motors (PMSM), brushless DC motors (BLDC)
 - Wide configurability via motor control library, associated GUI, and profiler
 - Tuning of drive dynamics
 - Selection of operating parameters such as switching frequency
 - Other parameter values for nominal and fault conditions: over current threshold
 - Torque or speed mode operation
- Fully protected
 - Overcurrent protection
 - Undervoltage lockout
 - Thermal shutdown
- Serial wire debug (SWD) port for debugging/programming
- Option for SPI, UART interface
- Easy user interface with buttons and trimmer

Product summary

Compact, configurable and customizable reference design for battery-operated brushless power tools based on STM32G431 and STDRIVE101	STDES-PTOOL3A
Mainstream Arm Cortex-M4 MCU 170 MHz	STM32G431RBT6
Triple half-bridge gate driver	STDRIVE101
N-channel 60 V, 0.0012 Ohm typ., 120 A STripFET F7 Power MOSFET	STL220N6F7
Applications	Motor Control

- Fault, status LEDs and interface for external LED for illumination
- Test land areas on the board for monitoring important signals or DAC outputs for debugging

Description

The [STDES-PTOOL3A](#) reference design is a compact system designed to control a BLDC/PMSM motor in a handheld battery powered tool.

It works on the standard set of inputs such as throttle to control the motor torque/speed and to deliver power up to 250W.

The board can be connected to a suitable 24V/250W power tool motor. More peak power can be delivered with heatsink or with arrangement for circulating air to achieve better power dissipation.

This reference design is ideal for high-performance motor control applications such in power tools such as drill machines, grinder, disc cutters, circular saws, leaf blowers, handheld mowers.

Small form factor and ample compute power make it suitable even for application such as drones, wheelchairs, home appliances and robotic platforms.

The board comprises a high performance [STM32G431RB](#) MCU featuring integrated op amps and comparators especially optimized for motor control applications along with a triple half bridge gate driver controlling six low voltages high current MOSFETS.

The MCU features multiple ADC peripherals thereby enabling simultaneous sampling of motor phase currents.

The board has the capability to implement both six-step and FOC algorithm. This results in high performance of six-step and field oriented control (FOC) of the hub motor.

1 Schematic diagrams

Figure 1. STDES-PTOOL3A schematic diagram (1 of 3)

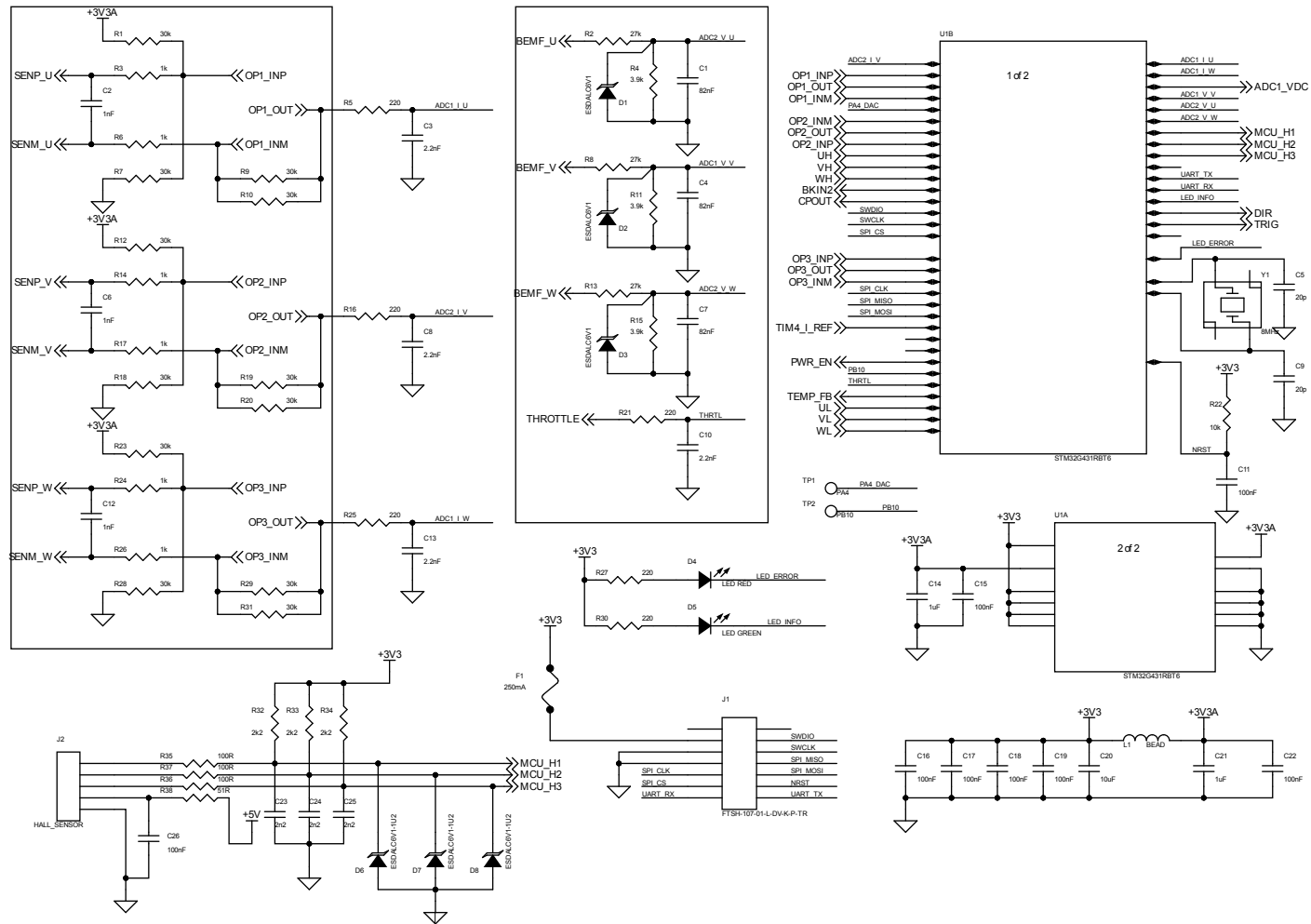

Figure 2. STDES-PTOOL3A schematic diagram (2 of 3)

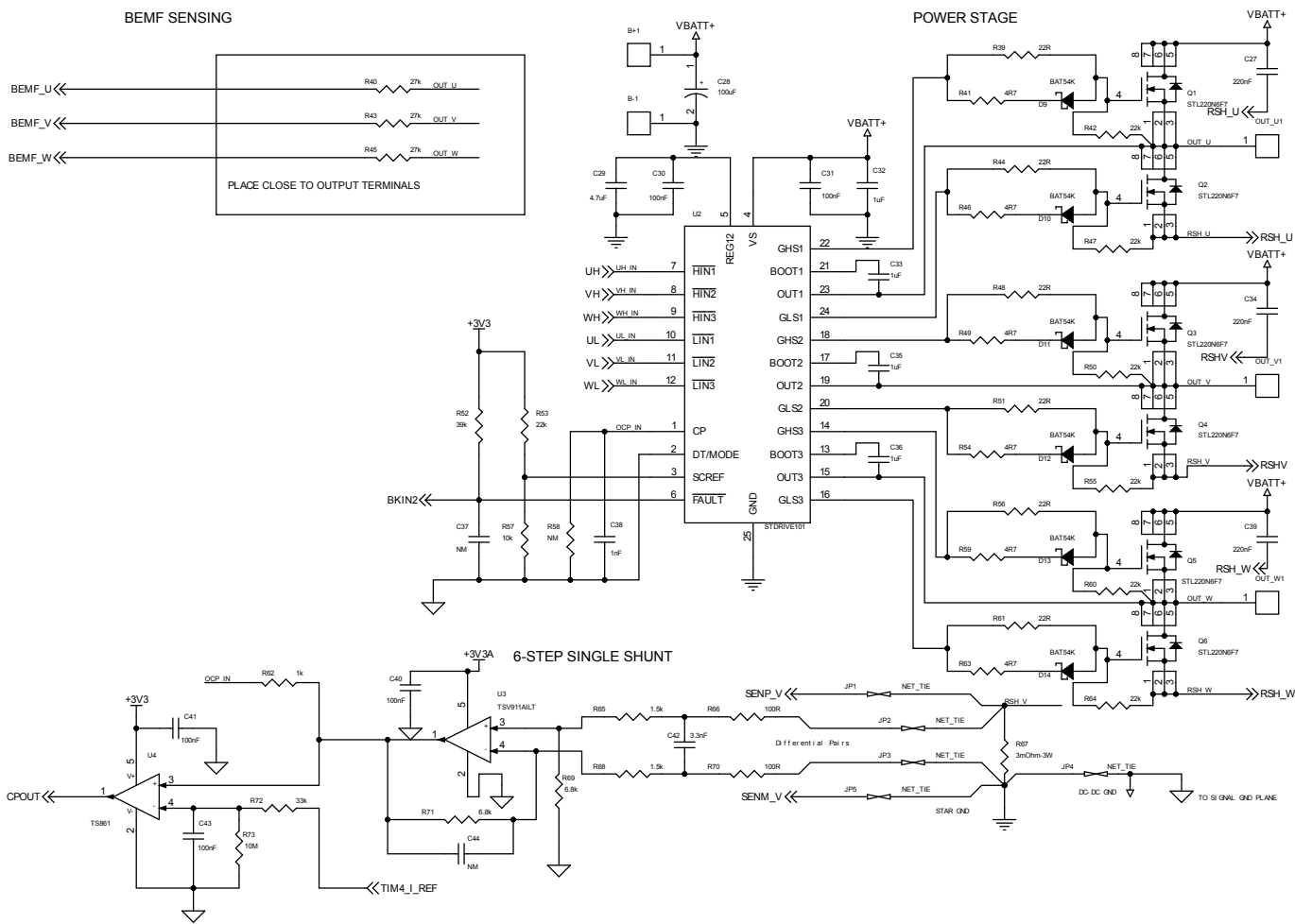
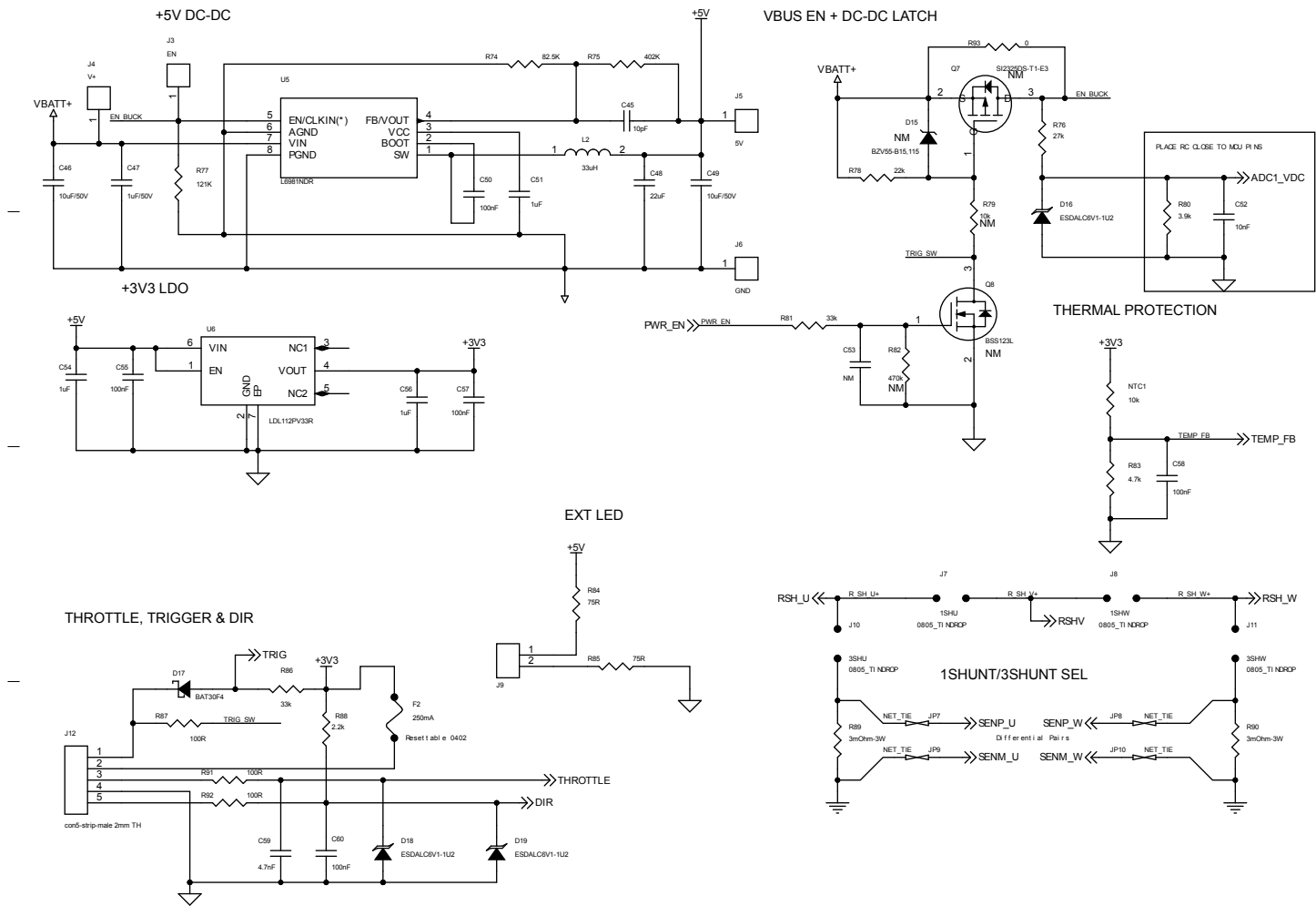

Figure 3. STDES-PTOOL3A schematic diagram (3 of 3)



Revision history

Table 1. Document revision history

Date	Revision	Changes
13-Mar-2023	1	Initial release.

IMPORTANT NOTICE – READ CAREFULLY

STMicroelectronics NV and its subsidiaries (“ST”) reserve the right to make changes, corrections, enhancements, modifications, and improvements to ST products and/or to this document at any time without notice. Purchasers should obtain the latest relevant information on ST products before placing orders. ST products are sold pursuant to ST’s terms and conditions of sale in place at the time of order acknowledgment.

Purchasers are solely responsible for the choice, selection, and use of ST products and ST assumes no liability for application assistance or the design of purchasers’ products.

No license, express or implied, to any intellectual property right is granted by ST herein.

Resale of ST products with provisions different from the information set forth herein shall void any warranty granted by ST for such product.

ST and the ST logo are trademarks of ST. For additional information about ST trademarks, refer to www.st.com/trademarks. All other product or service names are the property of their respective owners.

Information in this document supersedes and replaces information previously supplied in any prior versions of this document.

© 2023 STMicroelectronics – All rights reserved