

### Features:

- Power rating to 3 W
- Operation temperature range is -55 to +170°C
- Insulation resistance over 100MΩ
- Maximum working voltage (V) is  $(P \cdot R)^{1/2}$
- RoHS compliant, REACH compliant, lead free and halogen free
- AEC-Q200 compliant

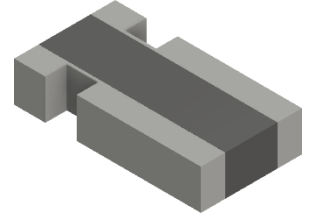

### Electrical Specifications

Type/Code	Power Rating (W) @ 70°C	TCR (ppm/°C)	Ohmic Range (Ω) and Tolerance	
			0.5%	1%, 5%
CSSK0612	1	± 100	-	0.0005 - 0.005
CSSK3637	3	± 50	0.0005 - 0.006	0.0005 - 0.006

### Mechanical Specifications

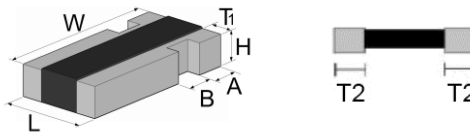

Type/Code	L	W	A	B	H	T1	T2	Unit
CSSK0612	0.065 ± 0.008 1.65 ± 0.20	0.120 ± 0.010 3.05 ± 0.25	0.020 ± 0.005 0.51 ± 0.13	0.020 ± 0.005 0.51 ± 0.13	0.026 ± 0.008 0.65 ± 0.20	0.016 ± 0.010 0.40 ± 0.25	0.016 ± 0.010 0.40 ± 0.25	inches mm
CSSK3637_L500	0.360 ± 0.010 9.14 ± 0.25	0.378 ± 0.010 9.60 ± 0.25	0.059 ± 0.010 1.50 ± 0.25	0.047 ± 0.010 1.20 ± 0.25	0.029 ± 0.010 0.73 ± 0.25	0.091 ± 0.010 2.30 ± 0.25	0.087 ± 0.010 2.22 ± 0.25	inches mm
CSSK3637_L750	0.360 ± 0.010 9.14 ± 0.25	0.378 ± 0.010 9.60 ± 0.25	0.059 ± 0.010 1.50 ± 0.25	0.047 ± 0.010 1.20 ± 0.25	0.029 ± 0.010 0.73 ± 0.25	0.091 ± 0.010 2.30 ± 0.25	0.089 ± 0.010 2.27 ± 0.25	inches mm
CSSK3637_1L00	0.360 ± 0.010 9.14 ± 0.25	0.378 ± 0.010 9.60 ± 0.25	0.059 ± 0.010 1.50 ± 0.25	0.047 ± 0.010 1.20 ± 0.25	0.029 ± 0.010 0.73 ± 0.25	0.091 ± 0.010 2.30 ± 0.25	0.091 ± 0.010 2.32 ± 0.25	inches mm
CSSK3637_2L00	0.360 ± 0.010 9.14 ± 0.25	0.378 ± 0.010 9.60 ± 0.25	0.059 ± 0.010 1.50 ± 0.25	0.047 ± 0.010 1.20 ± 0.25	0.029 ± 0.010 0.73 ± 0.25	0.091 ± 0.010 2.30 ± 0.25	0.079 ± 0.010 2.00 ± 0.25	inches mm
CSSK3637_3L00	0.360 ± 0.010 9.14 ± 0.25	0.378 ± 0.010 9.60 ± 0.25	0.059 ± 0.010 1.50 ± 0.25	0.047 ± 0.010 1.20 ± 0.25	0.029 ± 0.010 0.73 ± 0.25	0.091 ± 0.010 2.30 ± 0.25	0.079 ± 0.010 2.00 ± 0.25	inches mm
CSSK3637_5L00	0.360 ± 0.010 9.14 ± 0.25	0.378 ± 0.010 9.60 ± 0.25	0.059 ± 0.010 1.50 ± 0.25	0.047 ± 0.010 1.20 ± 0.25	0.029 ± 0.010 0.73 ± 0.25	0.091 ± 0.010 2.30 ± 0.25	0.091 ± 0.010 2.32 ± 0.25	inches mm
CSSK3637_6L00	0.360 ± 0.010 9.14 ± 0.25	0.378 ± 0.010 9.60 ± 0.25	0.059 ± 0.010 1.50 ± 0.25	0.047 ± 0.010 1.20 ± 0.25	0.029 ± 0.010 0.73 ± 0.25	0.091 ± 0.010 2.30 ± 0.25	0.091 ± 0.010 2.32 ± 0.25	inches mm

Performance Characteristics				
Test	Test Method	Test Specification		Test Condition
		CSSK0612	CSSK3637	
Temperature Coefficient of Resistance	IEC60115-1-4.8 JIS-C5201-4.8	As per specification		At +25°C/+150°C, 25°C is the reference temperature
Load Life	IEC60115-1-4.25.1 JIS-C5201-4.25.1	$\Delta R/R1 \leq \pm(2\% + 0.0005\Omega)$	$\Delta R/R1 \leq \pm(1\% + 0.0005\Omega)$	1000 hours at rated power, 70°C, 1.5 hours "ON", 0.5 hour "OFF".
Short Time Overload	IEC60115-1-4.13 JIS-C5201-4.13	$\Delta R/R1 \leq \pm(0.5\% + 0.0005\Omega)$		5 times rated power for 5 seconds
Moisture no Load	IEC60115-1-4.24.2.1a JIS-C5201-4.24.2.1a	$\Delta R/R1 \leq \pm(0.5\% + 0.0005\Omega)$		85°C, 85% RH, 1000 hours
Biased Humidity	MIL-STD-202 Method 103	$\Delta R/R1 \leq \pm(0.5\% + 0.0005\Omega)$		1000 hours; 85°C/85% R.H., 10% of operating power. Measurement at 24 ± 4 hours after test conclusion.
CSSK0612 Temperature Cycle	IEC60115-1-4.19 JIS-C5201-4.19	< ± 1%	-	-55°C and +155°C, 300 cycle, 15 minutes per extreme condition.
CSSK3637 Temperature Cycle	JESD22 Method JA-104	-	$\Delta R/R1 \leq \pm(0.5\% + 0.0005\Omega)$	1000 cycles (-55 to + 155°C). Measurement at 24 ± 4 hours after test conclusion. 30 minutes maximum dwell time at each temperature extreme.
Resistance to Soldering Heat	IEC60115-1-4.18 JIS-C5201-4.18	$\Delta R/R1 \leq \pm(0.5\% + 0.0005\Omega)$		260 ± 5°C for 10 ± 1 seconds 2 cycles
Solderability	IEC60115-1-4.17 JIS-C5201-4.17	At least 95% of surface area of electrode shall be covered with new solder.		245 ± 5°C, 2 ± 0.5 seconds
High Temperature Exposure	IEC60115-1-4.23.2 JIS-C5201-4.23.2	$\Delta R/R1 \leq \pm(2\% + 0.0005\Omega)$	$\Delta R/R1 \leq \pm(1\% + 0.0005\Omega)$	170°C, 1000 hours
Low Temperature Storage	IEC60115-1-4.23.4 JIS-C5201-4.23.4	< ± 0.5%	-	-55°C, 1000 hours
Dielectric Withstanding Voltage	JIS-C5201-1 4.7	No breakage.		Applied 500VAC for 1 minute.
Core Body Strength	JIS-C5201-1 4.15	$\Delta R/R1 \leq \pm(0.5\% + 0.0005\Omega)$		Central part pressurizing force: 5 N, 10 seconds
Terminal Strength	AEC-Q200-006	$\Delta R/R1 \leq \pm(0.5\% + 0.0005\Omega)$		Pressurizing force 17.7 N for 60 seconds
Moisture Resistance	MIL-STD 202 Method 106	$\Delta R/R1 \leq \pm(0.5\% + 0.0005\Omega)$		T=24 hours / cycle, 10 cycles. Steps 7a & 7b not required. Unpowered.
Substrate Bending	IEC60115-1-4.33 JIS-5201-4.33	$\Delta R/R1 \leq \pm(0.5\% + 0.0005\Omega)$		Bending once 2 mm for 10 seconds
Insulation Resistance	IEC60115-1-4.6 JIS-5201-4.6	> 100MΩ	-	100 VDC for 1 minute

Operating temperature range is -55 to +170°C

Recommended storage temperature is 25 ± 5°C, Humidity: 60 ± 20%

### Power Derating Curve:

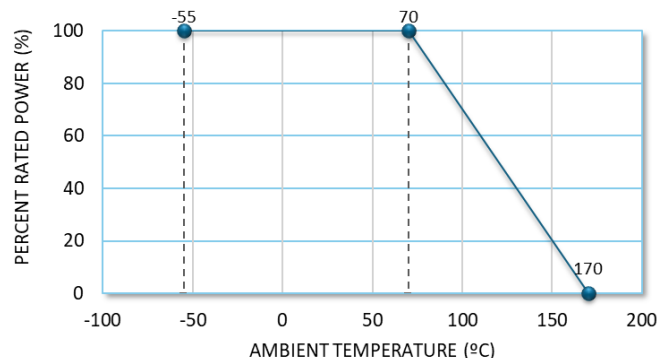

### Recommended Solder Pad

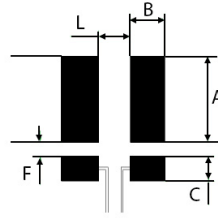

Type/Code	A	B	C	L	F	Unit
CSSK0612	0.091 2.30	0.039 1.00	0.031 0.80	0.028 0.70	0.016 0.40	inches mm
CSSK3637	0.312 7.92	0.130 3.30	0.078 1.98	0.157 4.00	0.024 0.60	inches mm

### Recommended Resistor Reflow Profile

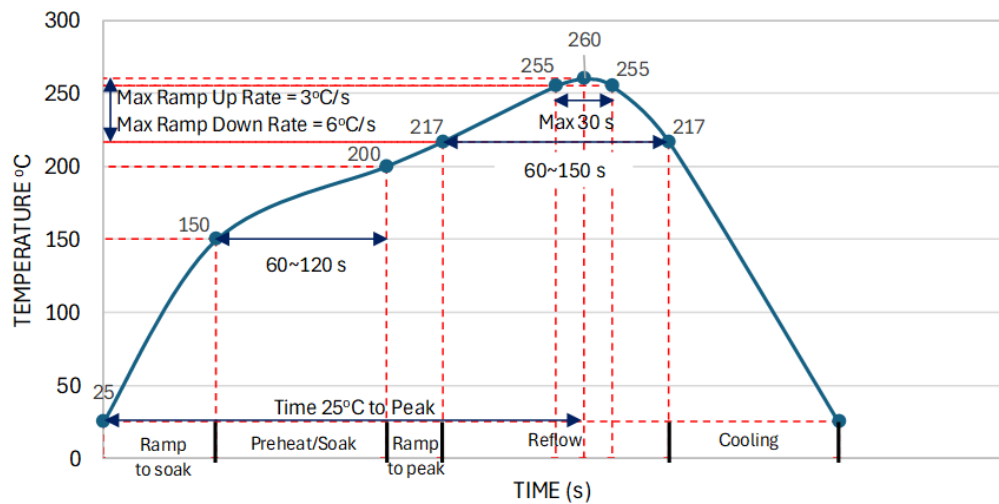

### Reel Specifications

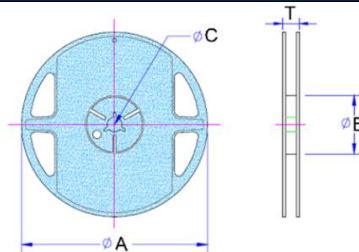

Type/Code	Carrier	ΦA	ΦB	ΦC	T	Unit
CSSK0612	Paper Tape	7.008 ± 0.079 178.00 ± 2.00	2.362 ± 0.039 60.00 ± 1.00	0.512 ± 0.039 13.00 ± 1.00	0.453 ± 0.039 11.50 ± 1.00	inches mm
CSSK3637	Plastic Tape	7.008 ± 0.079 178.00 ± 2.00	2.362 ± 0.039 60.00 ± 1.00	0.531 ± 0.020 13.50 ± 0.50	0.685 ± 0.039 17.40 ± 1.00	inches mm

**Taping Specifications - Paper Tape**

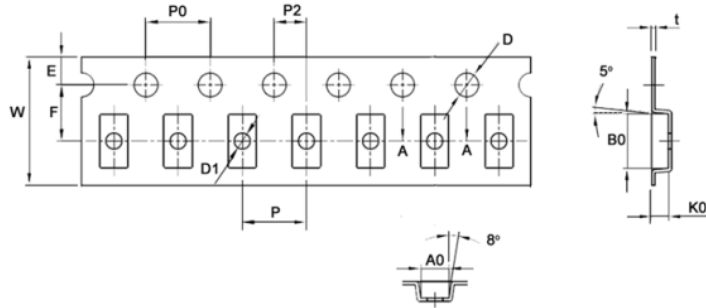

Type/Code	W	P	E	F	P2	D	Unit
CSSK0612 (Paper Tape)	0.315 ± 0.004 8.00 ± 0.10	0.157 ± 0.004 4.00 ± 0.10	0.069 ± 0.004 1.75 ± 0.10	0.138 ± 0.002 3.50 ± 0.05	0.079 ± 0.002 2.00 ± 0.05	0.059 ± 0.004 1.50 ± 0.10	inches mm
	D1	P0	A0	B0	K0	t	Unit
	0.039 ± 0.004 1.00 ± 0.10	0.157 ± 0.004 4.00 ± 0.10	0.070 ± 0.004 1.77 ± 0.10	0.134 ± 0.004 3.40 ± 0.10	0.041 ± 0.004 1.04 ± 0.10	0.009 ± 0.002 0.22 ± 0.05	inches mm

**Taping Specifications - Plastic Tape**

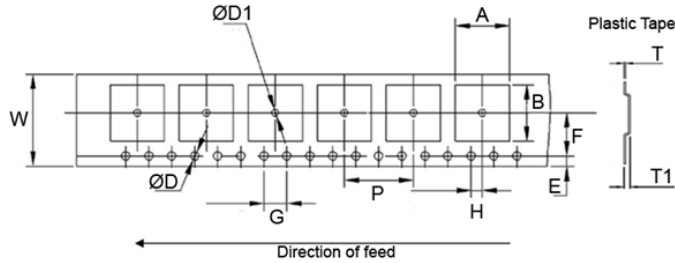

Type/Code	W	P	E	F	Ø D	Ø D1	Unit
CSSK3637 (Plastic Tape)	0.630 ± 0.008 16.00 ± 0.20	0.472 ± 0.004 12.00 ± 0.10	0.069 ± 0.004 1.75 ± 0.10	0.295 ± 0.004 7.50 ± 0.10	0.059 +0.004/-0 1.50 +0.10/-0	0.059 ± 0.004 1.50 ± 0.10	inches mm
	G	H	A	B	T1	T	Unit
	0.157 ± 0.004 4.00 ± 0.10	0.079 ± 0.004 2.00 ± 0.10	0.378 ± 0.004 9.60 ± 0.10	0.394 ± 0.004 10.00 ± 0.10	0.051 ± 0.004 1.30 ± 0.10	0.010 ± 0.002 0.25 ± 0.05	inches mm

**Peeling Strength of Top Cover Tape**

Test condition: 0.1 to 0.7 N at a peel-off speed of 300 mm/minute.

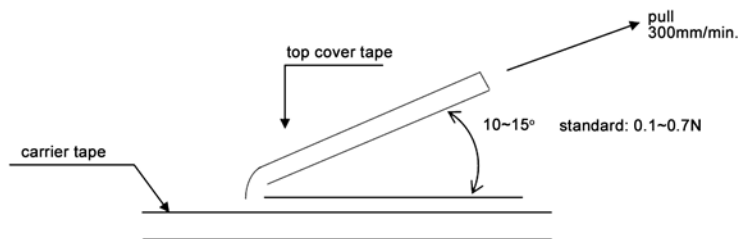

### RoHS Compliance

Stackpole Electronics has joined the worldwide effort to reduce the amount of lead in electronic components and to meet the various regulatory requirements now prevalent, such as the European Union's directive regarding "Restrictions on Hazardous Substances" (RoHS 3). As part of this ongoing program, we periodically update this document with the status regarding the availability of our compliant components. All our standard part numbers are compliant to EU Directive 2011/65/EU of the European Parliament as amended by Directive (EU) 2015/863/EU as regards the list of restricted substances.

RoHS Compliance Status				
Standard Product Series	Description	Package / Termination Type	Standard Series RoHS Compliant	Lead-Free Termination Composition
CSSK	Kelvin Termination Metal Alloy Current Sensing Resistor	SMD	YES	100% Matte Sn over Ni

### "Conflict Metals" Commitment

We at Stackpole Electronics, Inc. are joined with our industry in opposing the use of metals mined in the "conflict region" of the eastern Democratic Republic of the Congo (DRC) in our products. Recognizing that the supply chain for metals used in the electronics industry is very complex, we work closely with our own suppliers to verify to the extent possible that the materials and products we supply do not contain metals sourced from this conflict region. As such, we are in compliance with the requirements of Dodd-Frank Act regarding Conflict Minerals.

### Compliance to "REACH"

We certify that all passive components supplied by Stackpole Electronics, Inc. are SVHC (Substances of Very High Concern) free and compliant with the requirements of EU Directive 1907/2006/EC, "The Registration, Evaluation, Authorization and Restriction of Chemicals", otherwise referred to as REACH. Contact us for complete list of REACH Substance Candidate List.

### Environmental Policy

It is the policy of Stackpole Electronics, Inc. (SEI) to protect the environment in all localities in which we operate. We continually strive to improve our effect on the environment. We observe all applicable laws and regulations regarding the protection of our environment and all requests related to the environment to which we have agreed. We are committed to the prevention of all forms of pollution.

## How to Order

