

Features

Operating Conditions

- 1.8–5.5V, -40°C to +85°C, DC to 24 MHz
- 1.8–5.5V, -40°C to +125°C, DC to 24 MHz

Qualification

- AEC-Q100 Grade 1 (-40°C to +125°C)

Core: Arm® Cortex®-M0+ CPU Running at up to 24 MHz

- Single-cycle hardware multiplier

Memories

- Up to 128 KB in-system self-programmable Flash
- Up to 16 KB SRAM main memory

System

- Power-on Reset (POR) and Brown-out Detection (BOD)
- Internal and external clock options
- External Interrupt Controller (EIC)
- One non-maskable interrupt

Low Power

- Idle and Standby sleep modes
- SleepWalking peripherals

Input/Output (I/O)

- Up to 55 programmable I/O pins
- Up to 16 external interrupts
- Multi-Voltage I/O (MVIO)

Clock System

- Main Clock Controller (MCLK)
- Generic Clock Controller (GCLK)
- Clock sources:
 - Internal 1-24 MHz High Frequency Oscillator (OSCHF)
 - Internal 32.768 kHz Oscillator (OSC32K)
 - External 32.768 kHz Oscillator input (XOSC32K)

Debugger Development Support

- In-circuit and in-application programming
- 2-wire Serial Wire Debug Port Interface
- Four hardware breakpoints, one data watchpoint
- Micro Trace Buffer (MTB) for instruction trace in SRAM
- Programming and Debugging Interface Disable (PDID) functionality

Advanced Analog

- One 12-bit, 800 kps Analog-to-Digital Converter (ADC)
 - Differential and single-ended input
 - Automatic offset and gain error compensation
 - Oversampling and decimation in hardware to support up to 5 extra bits of resolution
- Two Analog Comparators (AC) with window compare function
- Peripheral Touch Controller (PTC) with up to 29 self-capacitance touch channels
- Internal and external voltage reference options

Peripherals

- 2-channel Direct Memory Access Controller (DMAC) with CRC Function
- 4-channel Event System
- Four 16-bit Timer/Counters:
 - Three 16-bit basic timers (TC0-2)
 - One 16-bit Timer/Counter for Control with four PWM channels (TCC0)
- 32-bit Real Time Counter (RTC) with clock/calendar function
- Watchdog Timer (WDT)
- Two Serial Communication Interfaces (SERCOM), configurable to operate as:
 - USART with full-duplex and single-wire half-duplex configuration

- ISO7816 UART
- I²C up to 1 MHz (SERCOM0)
- SPI
- LIN Host/Client
- RS-485
- Configurable Custom Logic (CCL) with four Look-Up Tables (LUT)
- Integrated Temperature Sensor

Available Packages

- 20-pin SSOP and VQFN
- 28-pin SSOP, SPDIP and VQFN
- 32-pin TQFP and VQFN
- 48-pin TQFP and VQFN
- 64-pin TQFP and VQFN

Family Overview

The figure below shows the PIC32CM PL10 Family devices and illustrates the pin count variants and memory sizes:

- Vertical migration is possible without code modification, as these devices are fully pin- and feature-compatible
- Horizontal migration to the left reduces the pin count and, therefore, the available features

Figure 1. PIC32CM PL10 Family Overview

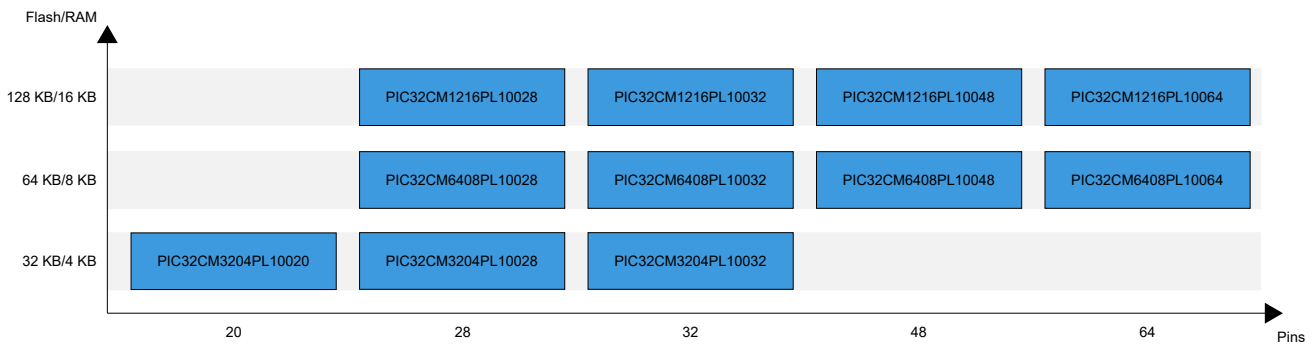

The name of a device in the PIC32CM PL10 Family is decoded as follows:

Figure 2. PIC32CM PL10 Family Family Device Designations

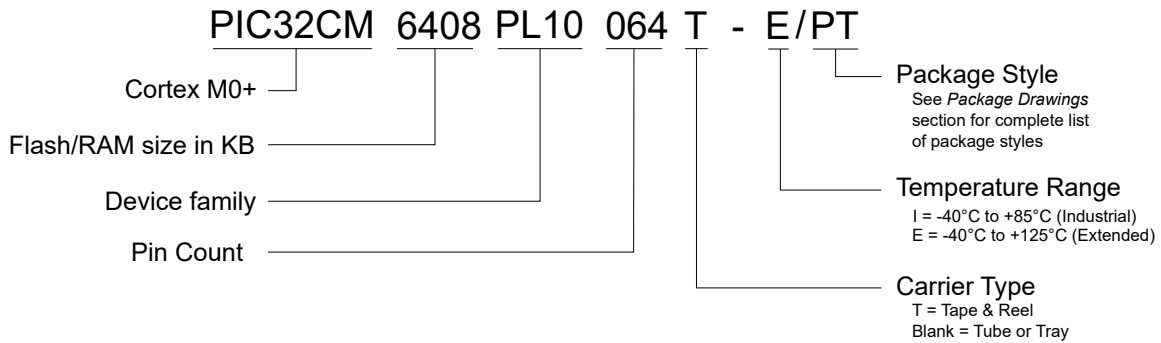

Note:

1. VQFN packages have wettable flanks.

Memory Overview

Table 1. Memory Overview

| Devices | CM3204-20 CM3204-28 CM3204-32 | CM6408-28 CM6408-32 CM6408-48 CM6408-64 | CM1216-28 CM1216-32 CM1216-48 CM1216-64 |
|--------------------|-------------------------------------|--|--|
| Flash memory | 32 KB | 64 KB | 128 KB |
| SRAM | 4 KB | 8 KB | 16 KB |
| Boot ROM (BOOTROM) | 8 KB | 8 KB | 8 KB |
| User row (USERROW) | 512B | 512B | 512B |

Peripheral Overview

Table 2. Peripheral Overview

| Feature | CM3204-20 | CM3204-28 CM6408-28 CM1216-28 | CM3204-32 CM6408-32 CM1216-32 | CM6408-48 CM1216-48 | CM6408-64 CM1216-64 |
|---|-----------|-------------------------------------|-------------------------------------|------------------------|------------------------|
| Pins | 20 | 28 | 32 | 48 | 64 |
| Max. frequency (MHz) | 24 | 24 | 24 | 24 | 24 |
| Generic Clock Controller (GCLK) | 4 | 4 | 4 | 4 | 4 |
| External High-Frequency Oscillator (XOSCHF) | 0 | 0 | 0 | 0 | 0 |
| External 32.768 kHz Oscillator | 1 | 1 | 1 | 1 | 1 |
| Timer/Counter (TC) | 3 | 3 | 3 | 3 | 3 |
| Timer/Counter for Control Applications (TCC) | 1 | 1 | 1 | 1 | 1 |
| Real-Time Counter (RTC) | 1 | 1 | 1 | 1 | 1 |
| Serial Communication Interface (SERCOM) | 2 | 2 | 2 | 2 | 2 |
| ADC (channels) | 1 (11) | 1 (16) | 1 (20) | 1 (25) | 1 (29) |
| DAC | 0 | 0 | 0 | 0 | 0 |
| Analog Comparator (AC) | 2 | 2 | 2 | 2 | 2 |
| Peripheral Touch Controller (PTC) and (channels) | 1 (11) | 1 (16) | 1 (20) | 1 (25) | 1 (29) |
| Operational Amplifier (OPAMP) | 0 | 0 | 0 | 0 | 0 |
| Configurable Custom Logic Look-up Table (CCL LUT) | 3 | 4 | 4 | 4 | 4 |
| Watchdog Timer (WDT) | 1 | 1 | 1 | 1 | 1 |
| Direct Memory Access Channels (DMA) | 2 | 2 | 2 | 2 | 2 |
| Event System channels (EVSYS) | 4 | 4 | 4 | 4 | 4 |
| General Purpose I/O ⁽¹⁾ | 17/16 | 23/22 | 27/26 | 42/41 | 56/55 |
| Multi-Voltage I/O (MVIO) | 3 | 4 | 4 | 8 | 8 |
| External Interrupts | 11 | 13 | 15 | 16 | 16 |

Note:

1. The PA30/RESET pin is input only.

1. Block Diagram

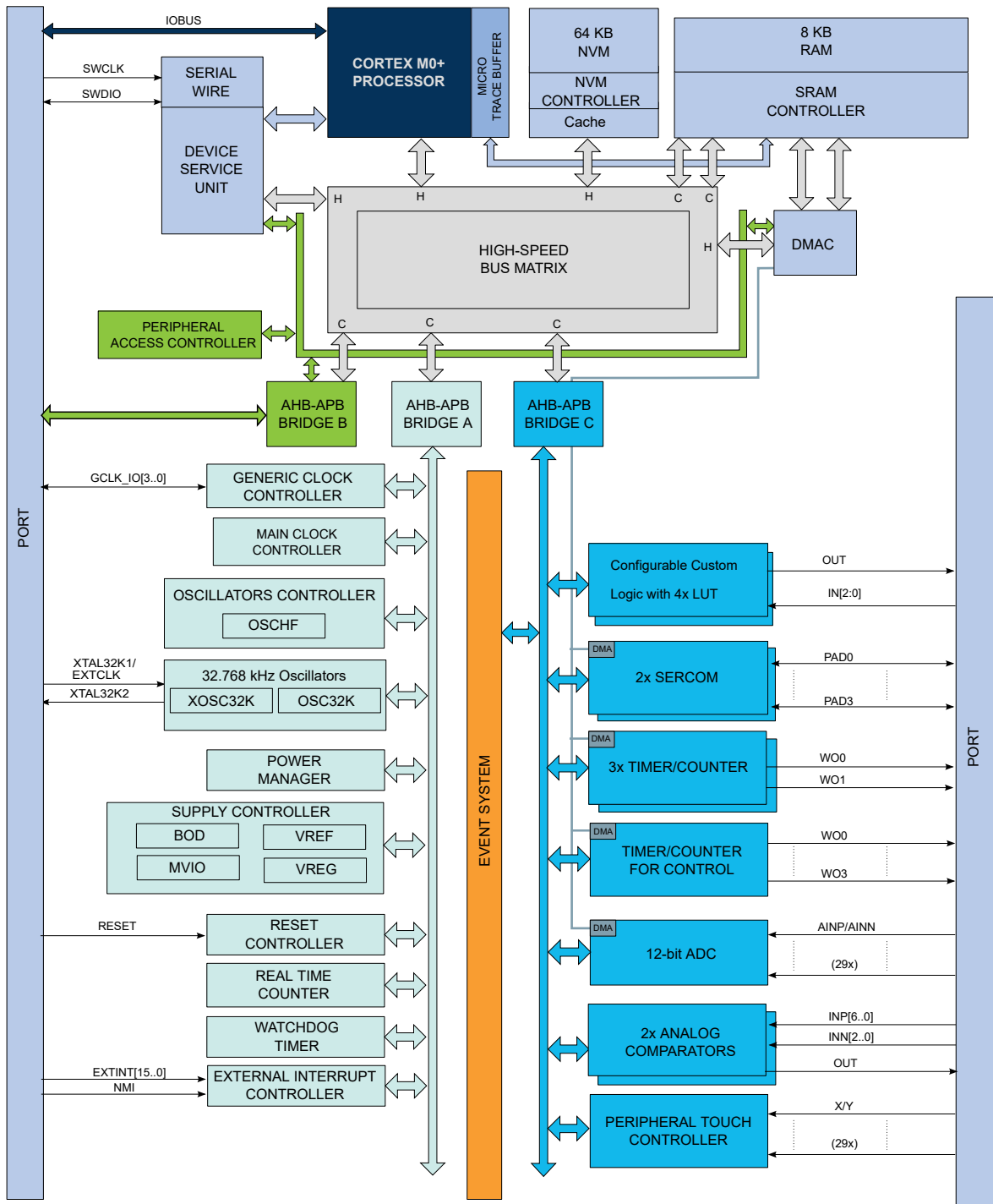



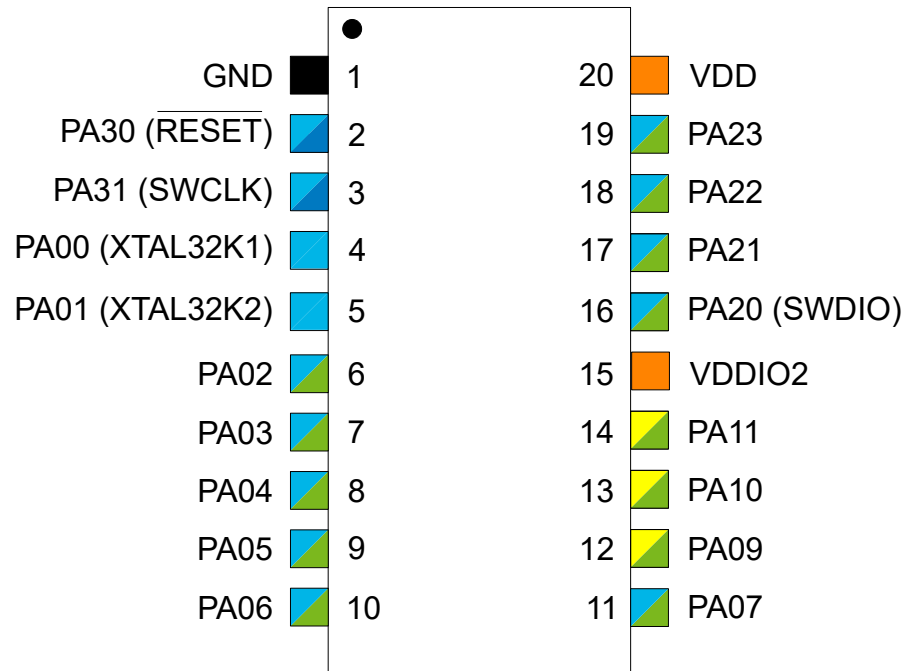

2. Pinout





2.1. 20-pin SSOP



Power

-  Power Supply
-  Ground
-  Pin on VDD Power Domain
-  Pin on AVDD Power Domain
-  Pin on VDDIO2 Power Domain



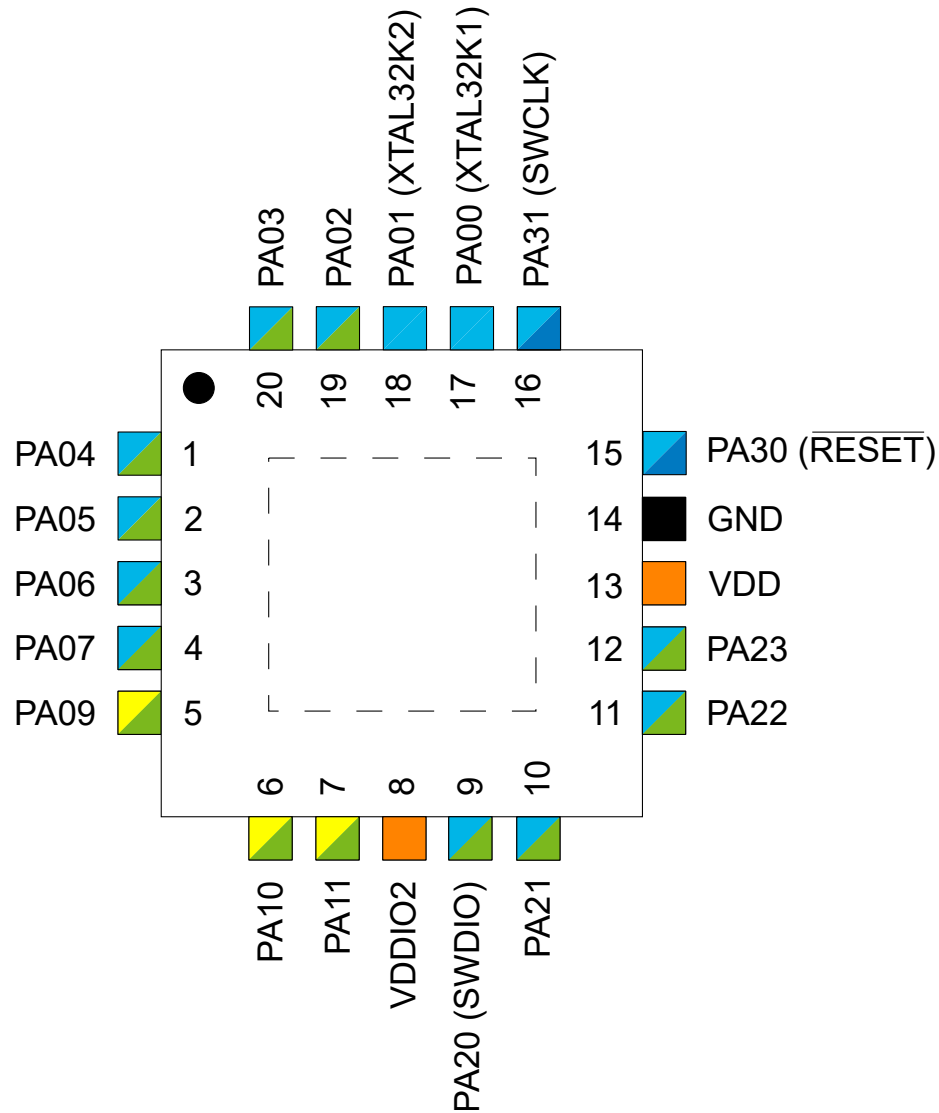

Functionality

-  Programming/Debug
-  Clock/Crystal
-  Digital Function Only
-  Analog Function





2.2. 20-pin VQFN



Power

-  Power Supply
-  Ground
-  Pin on VDD Power Domain
-  Pin on AVDD Power Domain
-  Pin on VDDIO2 Power Domain



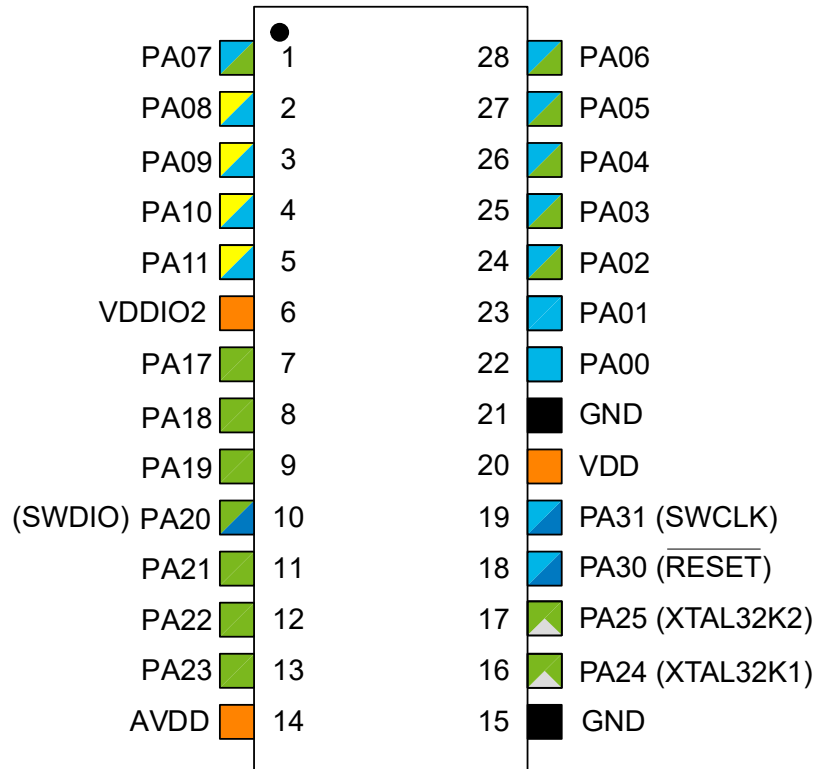

Functionality

-  Programming/Debug
-  Clock/Crystal
-  Digital Function Only
-  Analog Function





2.3. 28-pin SPDIP and SSOP



Power

-  Power Supply
-  Ground
-  Pin on VDD Power Domain
-  Pin on AVDD Power Domain
-  Pin on VDDIO2 Power Domain

Functionality

-  Programming/Debug
-  Clock/Crystal
-  Digital Function Only
-  Analog Function

2.4. 28-pin VQFN

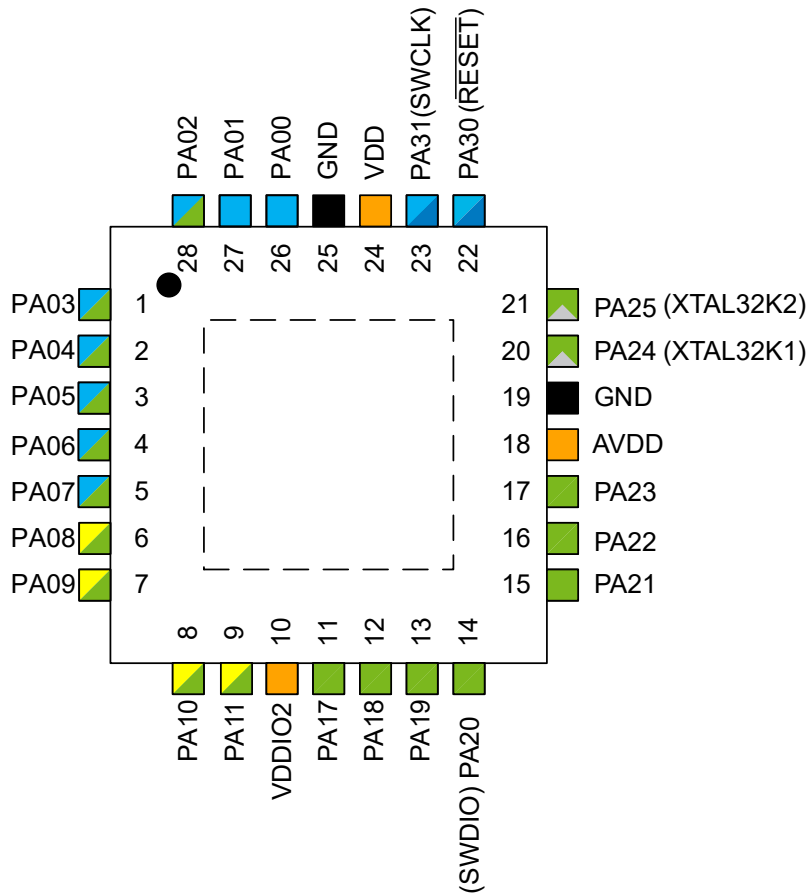

Power







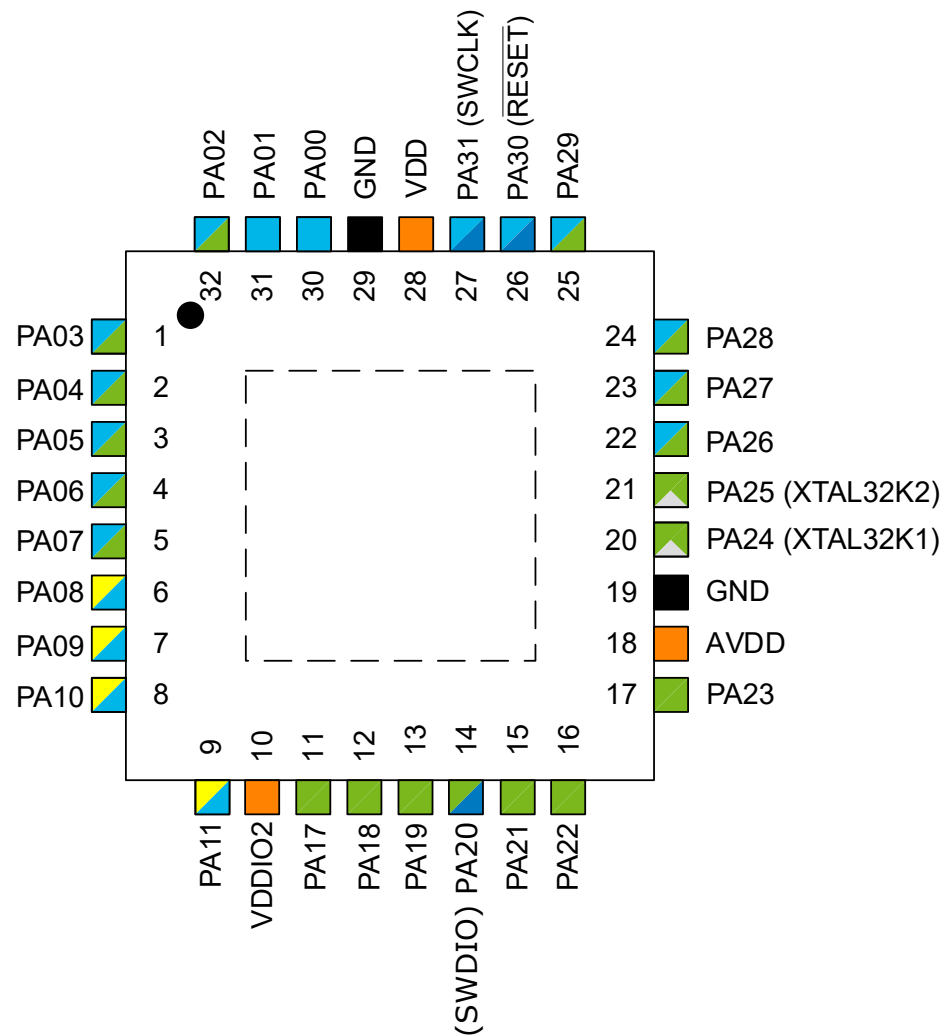

- Power Supply
- Ground
- Pin on VDD Power Domain
- Pin on AVDD Power Domain
- Pin on VDDIO2 Power Domain

Functionality

- Programming/Debug
- Clock/Crystal
- Digital Function Only
- Analog Function

2.5. 32-pin VQFN and TQFP



| Power | | Functionality | |
|---|----------------------------|---|-----------------------|
|  | Power Supply |  | Programming/Debug |
|  | Ground |  | Clock/Crystal |
|  | Pin on VDD Power Domain |  | Digital Function Only |
|  | Pin on AVDD Power Domain |  | Analog Function |
|  | Pin on VDDIO2 Power Domain | | |

2.6. 48-pin VQFN and TQFP

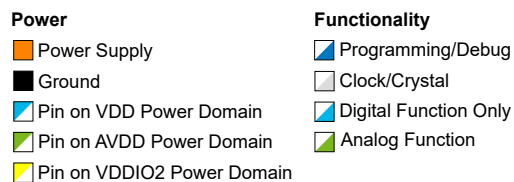
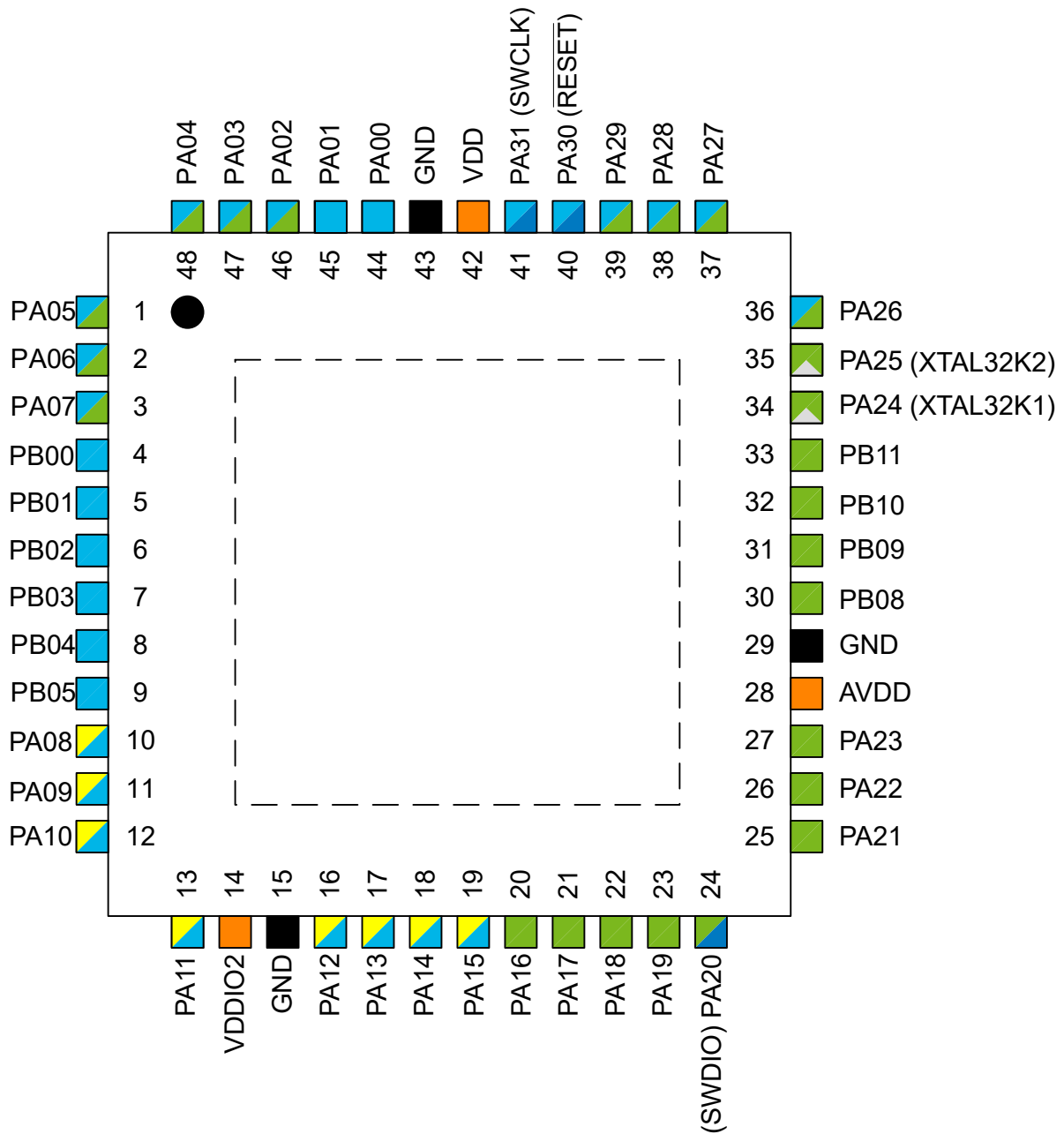

2.7. 64-pin VQFN and TQFP

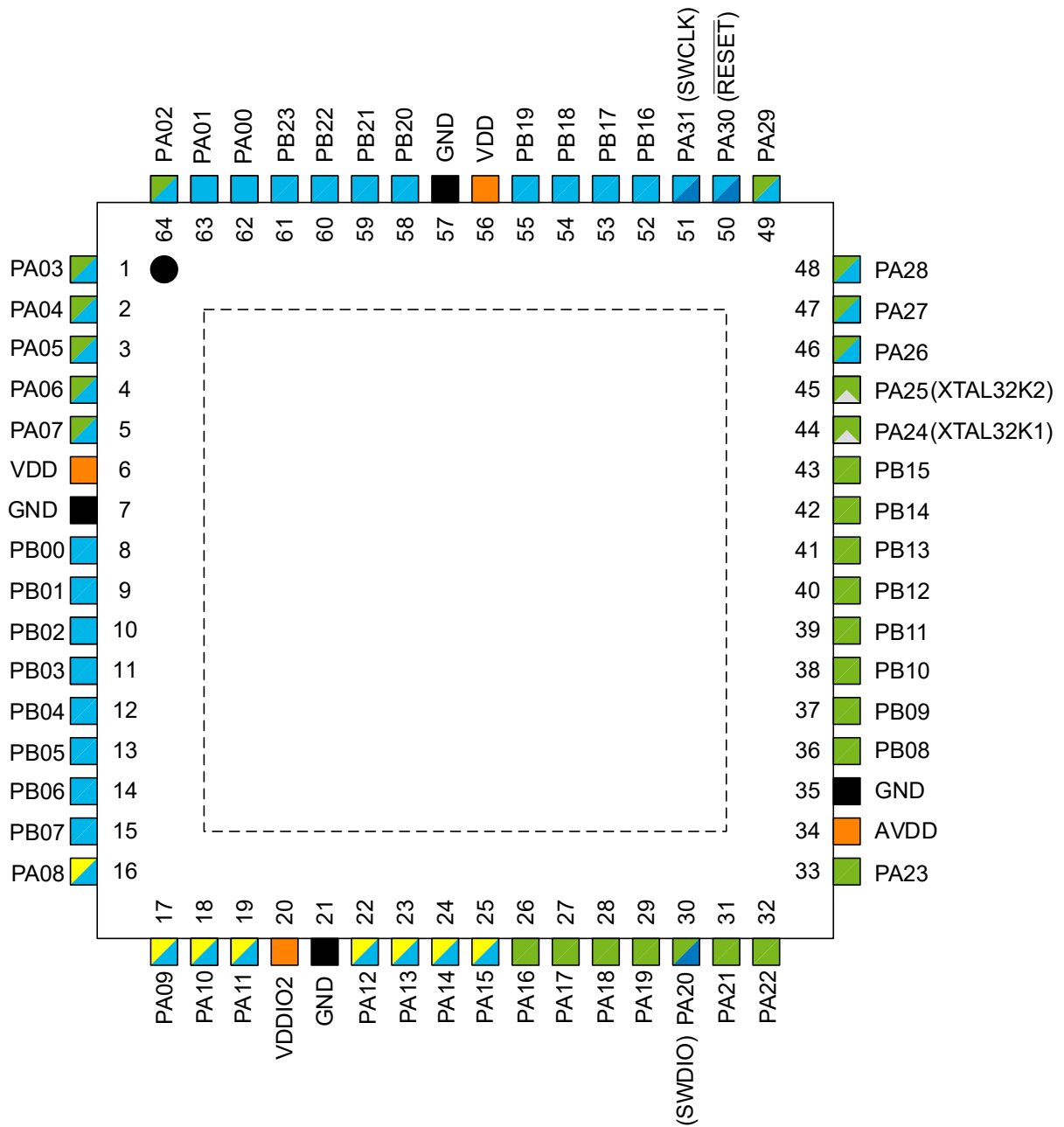

- | Power | Functionality |
|----------------------------|-----------------------|
| Power Supply | Programming/Debug |
| Ground | Clock/Crystal |
| Pin on VDD Power Domain | Digital Function Only |
| Pin on AVDD Power Domain | Analog Function |
| Pin on VDDIO2 Power Domain | |

3. I/O Multiplexing and Considerations

3.1. Pinout and Multiplexing

| Package/Pin Number | | | | | | | | A | | B | | | C | D | E | F | G | H | I | P | | | |
|--------------------|--------|--------|--------|--------|--------|--------|--------|-------------------------|------------|--------|--------|----------|-----------------|-------------------------|---------------------------|---------------------------|----------------------|--------------------|----------------------|----------------------|---------------------|---------|---------|
| 64-pin | 48-pin | 32-pin | 28-pin | 28-pin | 20-pin | 20-pin | SSOP | Pin name | Special | EXTINT | ADC0 | | PTC | ACn | SERCOMn | | TCn | TCC0 | | CCLn, ACn OUT | GCLKn | PTC X/Y | |
| | | | | | | | | | | | Pos | Neg | EXTCINT | | def. and alt. | alt. | | def. and alt. | SWCLK | | | | |
| 62 | 44 | 30 | 26 | 22 | 17 | 4 | PA00 | XTAL32K1 ⁽⁵⁾ | EXTINT[0] | | | | | | 0,PAD[0] ⁽²⁾ | 1,PAD[0] ⁽¹⁾ | 0,W00 ⁽¹⁾ | W00 | | 0,IN0 | 1,IO | | |
| 63 | 45 | 31 | 27 | 23 | 18 | 5 | PA01 | XTAL32K2 ⁽⁵⁾ | NMI | | | | | | 0,PAD[1] ⁽²⁾ | 1,PAD[1] ⁽¹⁾ | 0,W01 ⁽¹⁾ | W01 | | 0,IN1 | 2,IO | | |
| 64 | 46 | 32 | 28 | 24 | 19 | 6 | PA02 | | EXTINT[2] | AINP2 | AINN2 | | | | 0,PAD[2] | 1,PAD[2] ⁽¹⁾ | 1,W00 ⁽¹⁾ | W02 | | 0,IN2 | 3,IO | X2/Y2 | |
| 1 | 47 | 1 | 1 | 25 | 20 | 7 | PA03 | | EXTINT[3] | AINP3 | AINN3 | | | | 0,PAD[3] | 1,PAD[3] ⁽¹⁾ | 1,W01 ⁽¹⁾ | W03 | | 0,IO | 1,IO | X3/Y3 | |
| 2 | 48 | 2 | 2 | 26 | 1 | 8 | PA04 | | EXTINT[4] | AINP4 | AINN4 | | | | 0,PAD[0] ^(1,2) | | | | | | 1,IO ⁽¹⁾ | X4/Y4 | |
| 3 | 1 | 3 | 3 | 27 | 2 | 9 | PA05 | | EXTINT[5] | AINP5 | AINN5 | | | | 0,PAD[1] ^(1,2) | | | | | AC1 ⁽⁴⁾ | 2,IO ⁽¹⁾ | X5/Y5 | |
| 4 | 2 | 4 | 4 | 28 | 3 | 10 | PA06 | | EXTINT[6] | AINP6 | AINN6 | | | | 0,PAD[2] ⁽¹⁾ | | | | | 0,OUT ⁽¹⁾ | 3,IO ⁽¹⁾ | X6/Y6 | |
| 5 | 3 | 5 | 5 | 1 | 4 | 11 | PA07 | | NMI | AINP7 | AINN7 | | | | 0,PAD[3] ⁽¹⁾ | | | | | AC0 ⁽⁴⁾ | 0,IO ⁽¹⁾ | X7/Y7 | |
| 6 | | | | | | | | VDD | | | | | | | | | | | | | | | |
| 7 | | | | | | | | GND | | | | | | | | | | | | | | | |
| 8 | 4 | | | | | | PB00 | | EXTINT[0] | | | | | | | 1,PAD[0] ⁽¹⁾ | | W00 ⁽¹⁾ | | | | | |
| 9 | 5 | | | | | | PB01 | | EXTINT[1] | | | | | | | 1,PAD[1] ⁽¹⁾ | | W01 ⁽¹⁾ | | | | | |
| 10 | 6 | | | | | | PB02 | | EXTINT[2] | | | | | | | 1,PAD[2] ⁽¹⁾ | | W02 ⁽¹⁾ | | | | | |
| 11 | 7 | | | | | | PB03 | | EXTINT[3] | | | | | | | 1,PAD[3] ⁽¹⁾ | | W03 ⁽¹⁾ | | | | | |
| 12 | 8 | | | | | | PB04 | | EXTINT[4] | | | | | | | | | | | | | | |
| 13 | 9 | | | | | | PB05 | | EXTINT[5] | | | | | | | | | | | | | | |
| 14 | | | | | | | PB06 | | EXTINT[6] | | | | | | | | | | | | | | |
| 15 | | | | | | | PB07 | | EXTINT[7] | | | | | | | | | | | | | | |
| 16 | 10 | 6 | 6 | 2 | | | PA08 | VDDIO2 ⁽³⁾ | EXTINT[8] | | | | | | 1,PAD[2] | 0,PAD[2] ⁽¹⁾ | 1,W00 | W00 ⁽¹⁾ | | 1,IN0 | 1,IO ⁽¹⁾ | | |
| 17 | 11 | 7 | 7 | 3 | 5 | 12 | PA09 | VDDIO2 ⁽³⁾ | EXTINT[9] | | | | | | 1,PAD[3] | 0,PAD[3] ⁽¹⁾ | 1,W01 | W01 ⁽¹⁾ | | 1,IN1 | 2,IO ⁽¹⁾ | | |
| 18 | 12 | 8 | 8 | 4 | 6 | 13 | PA10 | VDDIO2 ⁽³⁾ | EXTINT[10] | | | | | | 1,PAD[0] | 0,PAD[0] ^(1,2) | 0,W00 | W02 ⁽¹⁾ | | 1,IN2 | 3,IO ⁽¹⁾ | | |
| 19 | 13 | 9 | 9 | 5 | 7 | 14 | PA11 | VDDIO2 ⁽³⁾ | EXTINT[11] | | | | | | 1,PAD[1] | 0,PAD[1] ^(1,2) | 0,W01 | W03 ⁽¹⁾ | | 1,OUT | 1,IO ⁽¹⁾ | | |
| 20 | 14 | 10 | 10 | 6 | 8 | 15 | VDDIO2 | | | | | | | | | | | | | | | | |
| 21 | 15 | | | | | | GND | | | | | | | | | | | | | | | | |
| 22 | 16 | | | | | | PA12 | VDDIO2 ⁽³⁾ | EXTINT[12] | | | | | | 1,PAD[2] ⁽¹⁾ | | | | | | | | |
| 23 | 17 | | | | | | PA13 | VDDIO2 ⁽³⁾ | EXTINT[13] | | | | | | 1,PAD[3] ⁽¹⁾ | | | | | AC1 ^(1,4) | | | |
| 24 | 18 | | | | | | PA14 | VDDIO2 ⁽³⁾ | EXTINT[14] | | | | | | 1,PAD[0] ⁽¹⁾ | | | | | 1,OUT ⁽¹⁾ | | | |
| 25 | 19 | | | | | | PA15 | VDDIO2 ⁽³⁾ | EXTINT[15] | | | | | | 1,PAD[1] ⁽¹⁾ | | | | | AC0 ^(1,4) | | | |
| 26 | 20 | | | | | | PA16 | | EXTINT[0] | AINP16 | AINN16 | | 0,N1 1,N1 | | | | W00 ⁽¹⁾ | | 2,IN0 | | | X16/Y16 | |
| 27 | 21 | 11 | 11 | 7 | | | PA17 | | EXTINT[1] | AINP17 | AINN17 | | | | | | W01 ⁽¹⁾ | | 2,IN1 | | | X17/Y17 | |
| 28 | 22 | 12 | 12 | 8 | | | PA18 | | EXTINT[2] | AINP18 | AINN18 | | 0,P0 1,P0 | | | | W02 ⁽¹⁾ | | 2,IN2 | | | X18/Y18 | |
| 29 | 23 | 13 | 13 | 9 | | | PA19 | | EXTINT[3] | AINP19 | AINN19 | | 0,N0 1,P1 | | | | W03 ⁽¹⁾ | | 2,OUT | | | X19/Y19 | |
| 30 | 24 | 14 | 14 | 10 | 9 | 16 | PA20 | SWDIO | EXTINT[4] | AINP20 | AINN20 | | 0,P5 1,P2 | 1,PAD[0] ⁽¹⁾ | | 2,W00 | | | | 2,IO ⁽¹⁾ | | X20/Y20 | |
| 31 | 25 | 15 | 15 | 11 | 10 | 17 | PA21 | | EXTINT[5] | AINP21 | AINN21 | EXTCINT0 | 0,P6 1,N0/P5 | 1,PAD[1] ⁽¹⁾ | | 2,W01 | | | | 3,IO ⁽¹⁾ | | X21/Y21 | |
| 32 | 26 | 16 | 16 | 12 | 11 | 18 | PA22 | | EXTINT[6] | AINP22 | AINN22 | EXTCINT1 | 0,P3 1,P3 | 1,PAD[2] ⁽¹⁾ | | | | | 2,OUT ⁽¹⁾ | 1,IO ⁽¹⁾ | | X22/Y22 | |
| 33 | 27 | 17 | 17 | 13 | 12 | 19 | PA23 | VREFA | EXTINT[7] | AINP23 | AINN23 | | 0,N2 1,N2 | 1,PAD[3] ⁽¹⁾ | | | | | | 0,IO ⁽¹⁾ | | X23/Y23 | |
| 34 | 28 | 18 | 18 | 14 | 13 | 20 | AVDD | | | | | | | | | | | | | | | | |
| 35 | 29 | 19 | 19 | 15 | 14 | 1 | AGND | | | | | | | | | | | | | | | | |
| 36 | 30 | | | | | | PB08 | | EXTINT[8] | AINP40 | AINN40 | | | | | | W00 ⁽¹⁾ | | | | | X40/Y40 | |
| 37 | 31 | | | | | | PB09 | | EXTINT[9] | AINP41 | AINN41 | | | | | | W01 ⁽¹⁾ | | | | | X41/Y41 | |
| 38 | 32 | | | | | | PB10 | | EXTINT[10] | AINP42 | AINN42 | | | | | | W02 ⁽¹⁾ | | | | | X42/Y42 | |
| 39 | 33 | | | | | | PB11 | | EXTINT[11] | AINP43 | AINN43 | | | | | | W03 ⁽¹⁾ | | | | | X43/Y43 | |
| 40 | | | | | | | PB12 | | EXTINT[12] | AINP44 | AINN44 | | | | | | | | | | | X44/Y44 | |
| 41 | | | | | | | PB13 | | EXTINT[13] | AINP45 | AINN45 | | | | | | | | | | | X45/Y45 | |
| 42 | | | | | | | PB14 | | EXTINT[14] | AINP46 | AINN46 | | | | | | | | | | | X46/Y46 | |
| 43 | | | | | | | PB15 | | EXTINT[15] | AINP47 | AINN47 | | | | | | | | | | | X47/Y47 | |
| 44 | 34 | 20 | 20 | 16 | | | PA24 | XTAL32K1 ⁽⁶⁾ | EXTINT[8] | AINP24 | AINN24 | | | | 1,PAD[2] ⁽¹⁾ | | W00 ⁽¹⁾ | | 3,IN0 | 1,IO ⁽¹⁾ | | X24/Y24 | |
| 45 | 35 | 21 | 21 | 17 | | | PA25 | XTAL32K2 ⁽⁶⁾ | EXTINT[9] | AINP25 | AINN25 | | | | 1,PAD[3] ⁽¹⁾ | | W01 ⁽¹⁾ | | 3,IN1 | 2,IO ⁽¹⁾ | | X25/Y25 | |
| 46 | 36 | 22 | | | | | PA26 | | EXTINT[10] | AINP26 | AINN26 | | | | 1,PAD[0] ⁽¹⁾ | | W02 ⁽¹⁾ | | 3,IN2 | 3,IO ⁽¹⁾ | | X26/Y26 | |
| 47 | 37 | 23 | | | | | PA27 | | EXTINT[11] | AINP27 | AINN27 | | | | 1,PAD[1] ⁽¹⁾ | | W03 ⁽¹⁾ | | 3,OUT | | | X27/Y27 | |
| 48 | 38 | 24 | | | | | PA28 | | EXTINT[12] | AINP28 | AINN28 | | | | | | | | | | | | X28/Y28 |
| 49 | 39 | 25 | | | | | PA29 | | EXTINT[13] | AINP29 | AINN29 | | | | | | | | | | 1,IO ⁽¹⁾ | | X29/Y29 |
| 50 | 40 | 26 | 22 | 18 | 15 | 2 | PA30 | RESET | NMI | | | | | | | | | | | | | | |
| 51 | 41 | 27 | 23 | 19 | 16 | 3 | PA31 | SWCLK | EXTINT[15] | AINP31 | AINN31 | | | 1,PAD[0] ⁽¹⁾ | 0,PAD[2] ⁽¹⁾ | | | SWCLK | | 0,IO ⁽¹⁾ | | X31/Y31 | |
| 52 | | | | | | | PB16 | | EXTINT[0] | | | | | | | | W00 ⁽¹⁾ | | | | | | |
| 53 | | | | | | | PB17 | | EXTINT[1] | | | | | | | | W01 ⁽¹⁾ | | | | | | |
| 54 | | | | | | | PB18 | | EXTINT[2] | | | | | | | | W02 ⁽¹⁾ | | | | | | |
| 55 | | | | | | | PB19 | | EXTINT[3] | | | | | | | | W03 ⁽¹⁾ | | | | | | |
| 56 | 42 | 28 | 24 | 20 | | | VDD | | | | | | | | | | | | | | | | |
| 57 | 43 | 29 | 25 | 21 | | | GND | | | | | | | | | | | | | | | | |

| Package/Pin Number | | | | | | | | | | A | | B | | | C | D | E | F | G | H | I | P |
|--------------------|--------|--------|--------|----------------|--------|--------|-----|-------------|---------|-----------|------|---------|------------------|-----|---------|------------------|----------------------|-------|-----|------------------|-------|-----|
| VQFN/ TQFP | | VQFN | | SSOP/ SPDIP | | VQFN | | Pin name | Special | EXTINT | ADC0 | | PTC | ACn | SERCOMn | | TCn | TCC0 | | CCLn, ACn OUT | GCLKn | PTC |
| 64-pin | 48-pin | 32-pin | 28-pin | 28-pin | 20-pin | 20-pin | Pos | | | | Neg | EXTCINT | def. and alt. | | alt. | def. and alt. | | SWCLK | X/Y | | | |
| | | | | | | | | PB20 | | EXTINT[4] | | | | | | | 2,W00 ⁽¹⁾ | | | | | |
| | | | | | | | | PB21 | | EXTINT[5] | | | | | | | 2,W01 ⁽¹⁾ | | | | | |
| | | | | | | | | PB22 | | EXTINT[6] | | | | | | | | | | | | |
| | | | | | | | | PB23 | | EXTINT[7] | | | | | | | | | | | | |

1. Alternative pin position. To select alternative pin positions, refer to the *Port Multiplexer* chapter.
2. This pin supports I²C with SERCOM0.
3. This pin is on the VDDIO2 power domain. For usage and properties, refer to the MVIO description in the *SUPC - Supply Controller* and in the *Electrical Characteristics* sections.
4. The output of the Analog Comparator to the pin can be used as input to the CCL. Refer also to the *CCL - Configurable Custom Logic* section.
5. Applicable only for 20-pin devices.
6. Not applicable for 20-pin devices.

4. Product Brief Revision History

Note: The product brief revision is independent of the die revision and the device variant (the last letter of the ordering number).

4.1. Rev. B - 02/2026

| Section | Description |
|-----------------|--|
| Document | Removed the 16 kB variant |
| Features | Minor updates and clarifications to the text |
| Family Overview | Updated figure; the 16 kB variant has been removed |

4.2. Rev. A - 09/2025

| Section | Description |
|----------|--------------------------|
| Document | Initial document release |

Microchip Information

Trademarks

The “Microchip” name and logo, the “M” logo, and other names, logos, and brands are registered and unregistered trademarks of Microchip Technology Incorporated or its affiliates and/or subsidiaries in the United States and/or other countries (“Microchip Trademarks”). Information regarding Microchip Trademarks can be found at <https://www.microchip.com/en-us/about/legal-information/microchip-trademarks>.

ISBN: 979-8-3371-2829-0

Legal Notice

This publication and the information herein may be used only with Microchip products, including to design, test, and integrate Microchip products with your application. Use of this information in any other manner violates these terms. Information regarding device applications is provided only for your convenience and may be superseded by updates. It is your responsibility to ensure that your application meets with your specifications. Contact your local Microchip sales office for additional support or, obtain additional support at www.microchip.com/en-us/support/design-help/client-support-services.

THIS INFORMATION IS PROVIDED BY MICROCHIP “AS IS”. MICROCHIP MAKES NO REPRESENTATIONS OR WARRANTIES OF ANY KIND WHETHER EXPRESS OR IMPLIED, WRITTEN OR ORAL, STATUTORY OR OTHERWISE, RELATED TO THE INFORMATION INCLUDING BUT NOT LIMITED TO ANY IMPLIED WARRANTIES OF NON-INFRINGEMENT, MERCHANTABILITY, AND FITNESS FOR A PARTICULAR PURPOSE, OR WARRANTIES RELATED TO ITS CONDITION, QUALITY, OR PERFORMANCE.

IN NO EVENT WILL MICROCHIP BE LIABLE FOR ANY INDIRECT, SPECIAL, PUNITIVE, INCIDENTAL, OR CONSEQUENTIAL LOSS, DAMAGE, COST, OR EXPENSE OF ANY KIND WHATSOEVER RELATED TO THE INFORMATION OR ITS USE, HOWEVER CAUSED, EVEN IF MICROCHIP HAS BEEN ADVISED OF THE POSSIBILITY OR THE DAMAGES ARE FORESEEABLE. TO THE FULLEST EXTENT ALLOWED BY LAW, MICROCHIP’S TOTAL LIABILITY ON ALL CLAIMS IN ANY WAY RELATED TO THE INFORMATION OR ITS USE WILL NOT EXCEED THE AMOUNT OF FEES, IF ANY, THAT YOU HAVE PAID DIRECTLY TO MICROCHIP FOR THE INFORMATION.

Use of Microchip devices in life support and/or safety applications is entirely at the buyer’s risk, and the buyer agrees to defend, indemnify and hold harmless Microchip from any and all damages, claims, suits, or expenses resulting from such use. No licenses are conveyed, implicitly or otherwise, under any Microchip intellectual property rights unless otherwise stated.

Microchip Devices Code Protection Feature

Note the following details of the code protection feature on Microchip products:

- Microchip products meet the specifications contained in their particular Microchip Data Sheet.
- Microchip believes that its family of products is secure when used in the intended manner, within operating specifications, and under normal conditions.
- Microchip values and aggressively protects its intellectual property rights. Attempts to breach the code protection features of Microchip products are strictly prohibited and may violate the Digital Millennium Copyright Act.
- Neither Microchip nor any other semiconductor manufacturer can guarantee the security of its code. Code protection does not mean that we are guaranteeing the product is “unbreakable”. Code protection is constantly evolving. Microchip is committed to continuously improving the code protection features of our products.

Product Page Links

[PIC32CM1216PL10028](#), [PIC32CM1216PL10032](#), [PIC32CM1216PL10048](#), [PIC32CM1216PL10064](#),
[PIC32CM3204PL10020](#), [PIC32CM3204PL10028](#), [PIC32CM3204PL10032](#), [PIC32CM6408PL10028](#),
[PIC32CM6408PL10032](#), [PIC32CM6408PL10048](#), [PIC32CM6408PL10064](#)