

1500W, 9 to 80V Input Non-Isolated DC-DC Buck-Boost Converter with PHEPT*

*Programmable High Efficiency Pass-Through



The i9C Series DC-DC buck-boost converter highlights its key innovation: Programmable High-Efficiency Pass-Through (PHEPT) mode. Using patented technology, PHEPT allows designers to define an input-voltage window in which the module bypasses regulation and directly connects input to output, eliminating switching and conversion losses. This improves efficiency, reduces thermal stress, and extends battery runtime. The converter supports 9–80 V or 9–40 V inputs and 9.6–60 V or 5–36 V outputs, delivering up to 1500 W for 12 V, 24 V, 48 V, and 60 V bus architectures. Its compact wide quarter-brick package with baseplate enables flexible cooling options. Features include wide output adjustment, negative logic On/Off control, power good, remote sense, user-adjustable overcurrent protection, low-power sleep mode, and full auto-recovery protection. Designed for high-ambient, low-airflow environments, it is ideal for industrial, telecom, test and measurement, and battery-powered applications, including AGVs, AMRs, and drones.

Features	Benefits
• Up to 1500W in a Compact, Wide Quarter Brick Package	• High Power Density, Less Board Area Needed
• User Programmable PHEPT Window, Up to 99% Efficiency	• Reduces Energy Consumption, Extends Battery Runtimes
• Wide Operating Input Voltage Range	• Operates From Multiple DC Sources, Including Batteries
• Wide Output Voltage Adjustment Range	• One Part Supports Multiple System Voltages
• User Configurable Sleep Mode	• Puts Module in Low Power Dissipation State During Idle or Light-Load Conditions
• Adjustable Overcurrent Protection	• Reduces Device Stress and Helps Eliminate External Circuits

Model Selector									
Model	Max O/P Power (W)	Input Voltage (V)	Output Voltage (V)	Max O/P Current (A)	Typical Efficiency		Baseplate Design	Adjustable OCP	SLEEP Mode Function
					Fully Regulated Mode	PHEPT Mode			
I9C4W030A480V-OC3-R #	1500	9 - 80	9.6 - 60	30	97%	99%	Flanged	Yes	Yes
I9C4W030A480V-NC3-R	1500	9 - 80	9.6 - 60	30	97%	99%	Non-Flanged	Yes	Yes
I9C2W050A240V-OC3-R #	1500	9 - 40	5 - 36	50	95%	97.5%	Flanged	Yes	Yes
I9C2W050A240V-NC3-R	1500	9 - 40	5 - 36	50	95%	97.5%	Non-Flanged	Yes	Yes

Contact Technical Support for availability.

Preferred model

Related Products		
Type	Part Number	Description
DC-DC Buck Converter	I3A	100W, Input 9-53V, Output 5-30V 4.5A or 3.3-16.5V 8A
DC-DC Buck Converter	I6A4W	250W, Input 9-53V, Output 3.3-40V 10A or 3.3-15V 20A
DC-DC Buck-Boost Converter	I1C	200W, Input 9-36V or 18-75V, Output 9.6-28V, 1x1 inch Footprint
DC-DC Buck-Boost Converter	I7C	300W, Input 9-53V or 9-36V, Output 9.6-48V 8A, 5-28V 12.5A or 8-24V 20A
DC-DC Buck Converter	RGA	250W, Input 9 up to 53V, Output 3.3 up to 40V, Rugged Modules
DC-DC Buck Converter	RGB	400-750W, Input 9 to 18V or 18 up to 60V, Output 0.8 to 8V or 3.3 up to 24V, Rugged Modules
DC-DC Buck-Boost Converter	RGC	300W, Input 9-53V, Output 9.6-48V 8A or 5-28V 12.5A, Rugged Modules
AC-DC Power Module	PFE-FB	1500-1800W, 85-305Vac, 50/60/400Hz, 48V, 60V, 28V output, Digital Control/PMBus
Filter Module	RGE	80V, 20A or 40A Differential Mode Filter Module
ORing FET Module	I1R	60V/60A; 30V/80A ORing FET (Ideal Diode) Modules
Evaluation Kit	I9C30A-C03-EVK-S1	Evaluation kit with I9C4W030A480V-OC3-R Module
Evaluation Kit	I9C50A-C03-EVK-S1	Evaluation kit with I9C2W050A240V-OC3-R Module

Specification		
Model	<div style="display: flex; justify-content: space-between;"> 19C4W030A480V 19C2W050A240V </div>	
Environmental		
Operating Baseplate Temperature	°C	-40 to 117 (For Derating, please refer to I9C Specifications)
Storage Temperature	°C	-55 to 125
Humidity (non condensing)	%RH	5 - 95 (Operating & Storage)
Operating Altitude	m	up to 5000
Cooling	-	Convection, conduction (baseplate) or forced air
Random Vibration	-	MIL-STD-810G Method 514.6 Procedure I Category 4
Shock (Operating)	-	MIL-STD-810G Method 516.6 Procedure I Table 516.6-1
Other		
Weight (max)	g	115
Size (LxWxH)	mm	57.91 x 55.88 x 15.25
MTBD - Telcordia SR-332	hr	>10M; Ta = 40°C
Warranty	Yrs	3

Notes

- 1 Refer to i9C Specifications.
- 2 Over all rated line, load, temperature conditions to end of life.
- 3 Observe maximum power limit and the operating range chart.
- 4 Due to wide variation in input and output conditions, i9C performance (including output ripple and transient response) may vary by application. Performance should be verified in the end use. TDK-Lambda can assist with external component selection; contact technical support, particularly when using very low-ESR capacitor banks or values beyond those listed.
- 5 With minimum output capacitance, Co,min. i9C2W with additional 2X 22µF ceramic.
- 6 If operating in range where input and output voltage are both near the minimum specified value, use of an output capacitance above the minimum is recommended

Typical Application Circuit

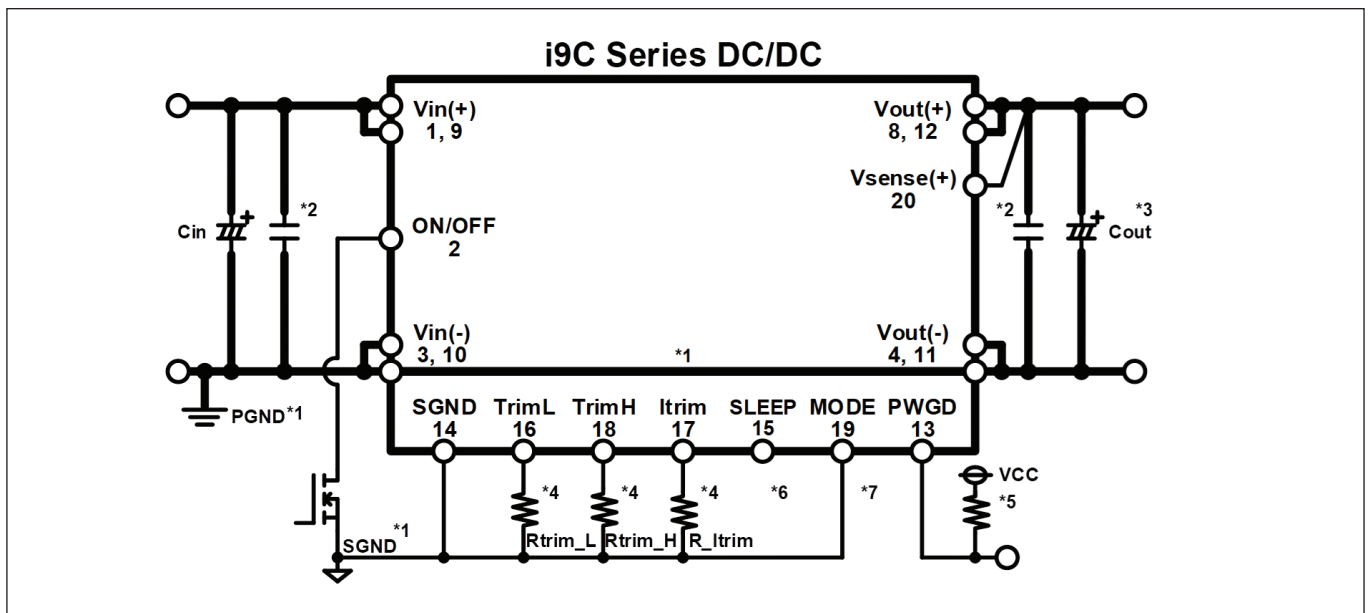

Design Guideline / Recommendation

1. Power GND and Signal GND (SGND) should be separated. Vin(-) and Vout(-) should be connected by a heavy copper ground plane underneath the i9C module. Pin 14 SGND, is internally grounded.
2. Input and Output MLCC should be placed close to the i9C module to reject high frequency noise. Minimum 4 x 22µF recommended at input and 2 x 22µF at output.
3. Cout bulk capacitors may carry significant ripple current especially during step-up operation. Cin bulk capacitors may carry significant ripple current especially during step-down operation. Please check ripple current capability of capacitor versus actual measured current.
4. TRIM resistors must connect to Signal GND. Itrim pin must be tied directly to SGND if this feature is not used.
5. PWGD (Power Good) is open-drain. Refer to Operating Information description.
6. SLEEP pin state (open or grounded) is critical for proper operation, please refer to the I9C Specifications.
7. Refer to Operating Information description in the I9C Specifications to understand use of MODE pin.

Simplified Block Diagram for Redundant / Parallel Configuration

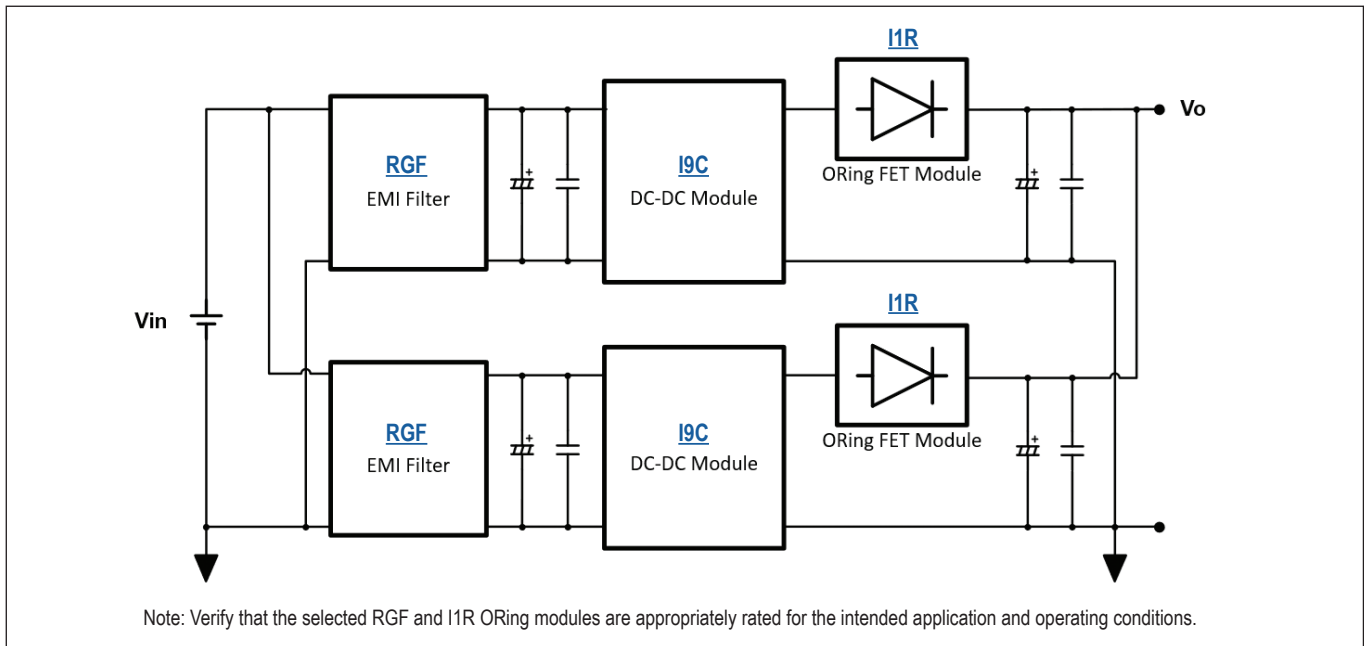

Output vs. Input Voltage Operating Range

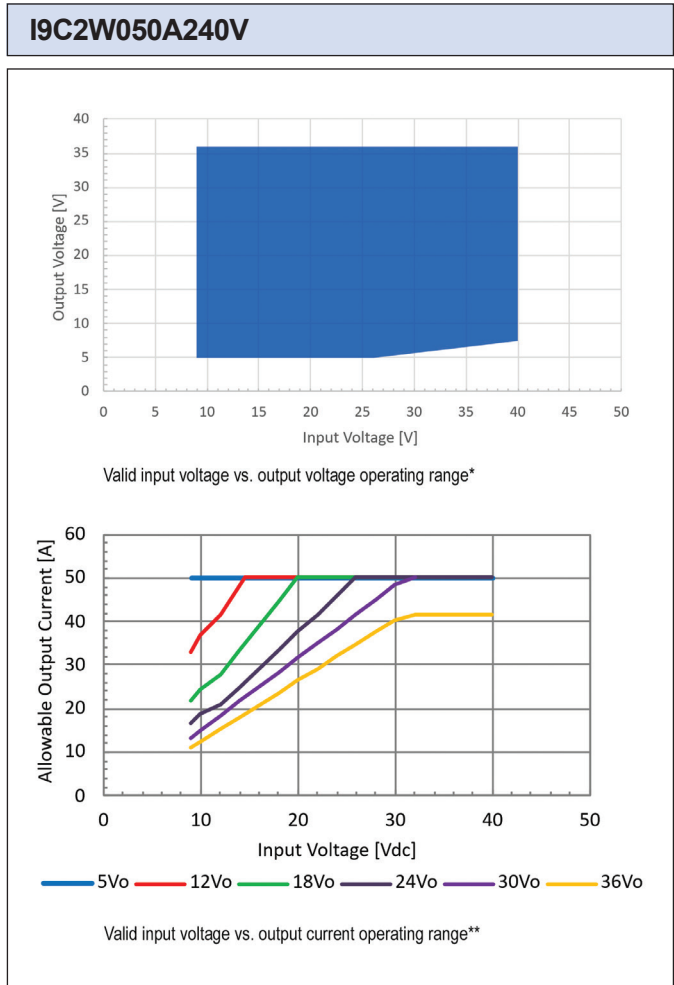
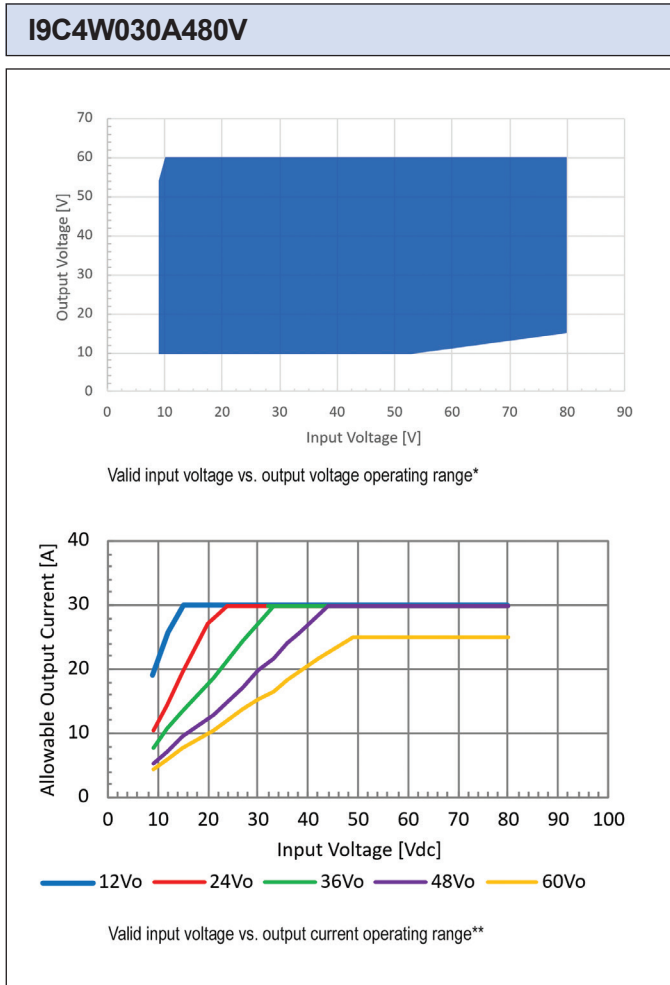

* Unit will not be damaged if operated at high lines with output voltage set below the region specified but within the specified output voltage operating range. In this region unit may have high ripple or not regulate the voltage properly at light loads
 ** Allowable output current is limited by combination of Vin and Vout during Step-up mode. Output voltage may start to decrease if allowable output current is exceeded..

Mechanical Specification

Outline Drawing (Baseplate)

Dimensions are in mm [in]. Unless otherwise specified, tolerances are: $x.x \pm 0.5$ [0.02] / $x.xx \pm 0.25$ [0.010]

To avoid damaging components, do not exceed 8.0 [0.32] depth with M3 screws

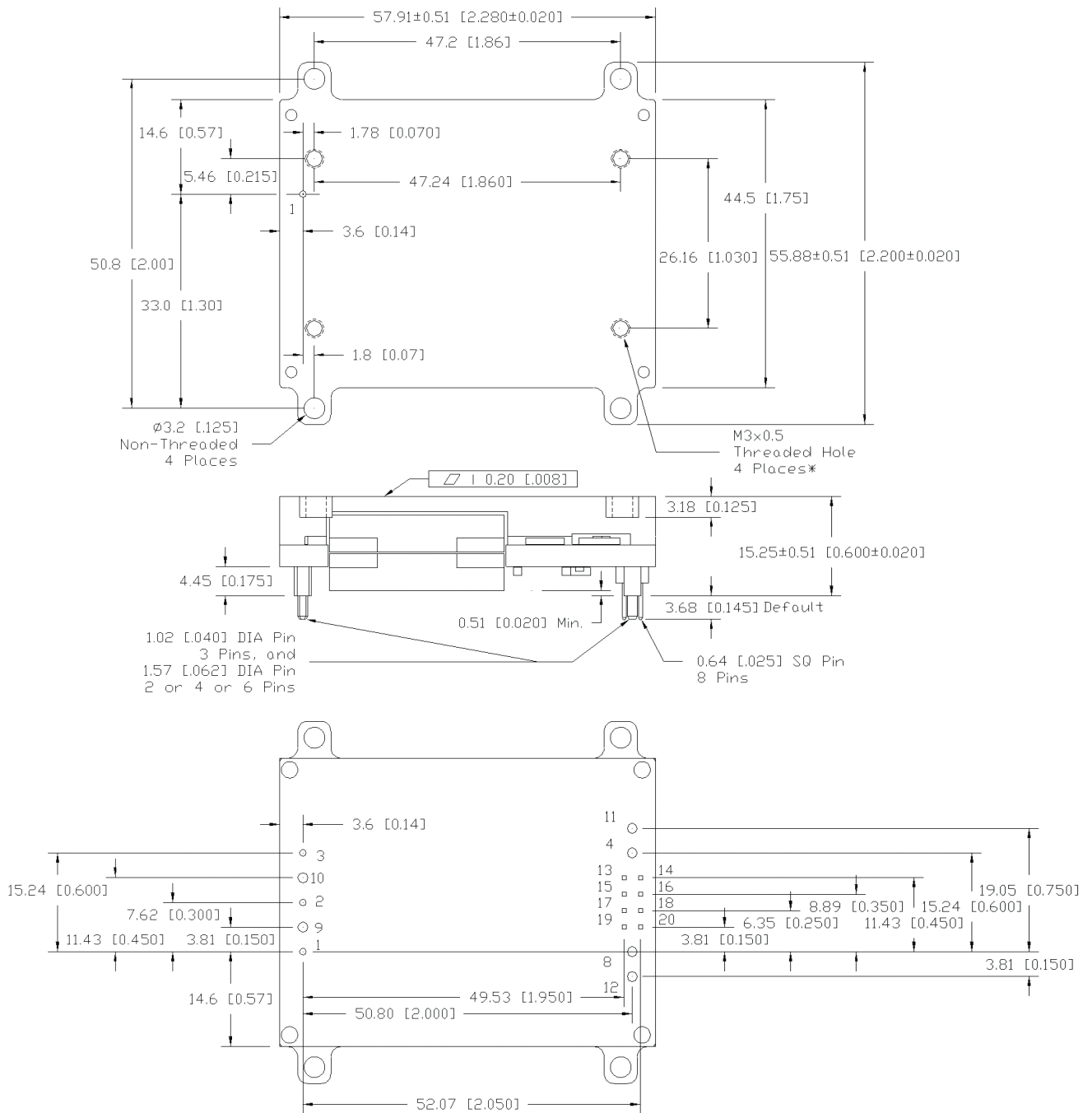

Mechanical Specification

Recommended Hole Pattern (Top View)

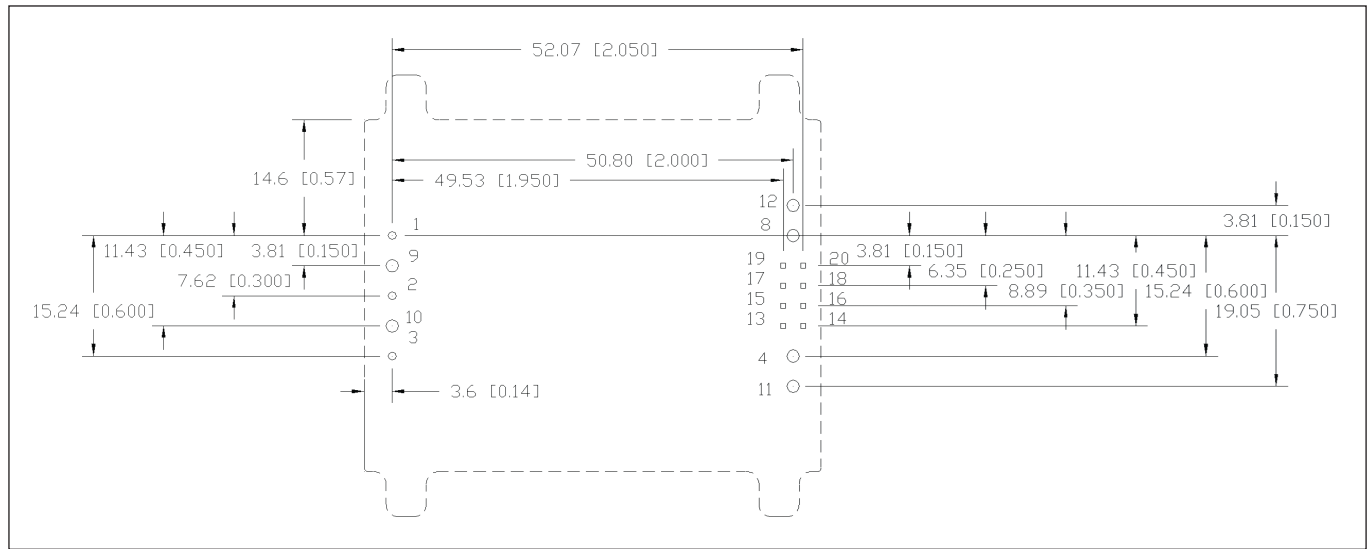

Pin Assignment

PIN	Function	PIN	Function	PIN	Function
1, 9	Vin (+)	13	PWGD	18	TrimH
2	On / Off	14	SGND	19	MODE
3, 10	Vin (-) / GND	15	SLEEP	20	Vsense(+)
4, 11	Vout (-) / GND	16	TrimL		
8, 12	Vout (+)	17	Itrim		



TDK-Lambda France SAS
 Tel: +33 1 60 12 71 65
 ttf.fr-powersolutions@tdk.com
 www.emea.lambda.tdk.com/fr



TDK-Lambda Americas
 Tel: +1 800-LAMBDA-4 or 1-800-526-2324
 tla.powersolutions@tdk.com
 www.us.lambda.tdk.com



Italy Sales Office
 Tel: +39 02 61 29 38 63
 ttf.it-powersolutions@tdk.com
 www.emea.lambda.tdk.com/it



TDK Electronics do Brasil Ltda
 Tel: +55 11 3289-9599
 sales.br@tdk-electronics.tdk.com
 www.tdk-electronics.tdk.com/en



Netherlands
 ttf.nl-powersolutions@tdk.com
 www.emea.lambda.tdk.com/nl



TDK-Lambda Corporation
 Tel: +81-3-6778-1113
 www.jp.lambda.tdk.com



TDK-Lambda Europe GmbH
 Tel: +49 7841 666 0
 tlg.powersolutions@tdk.com
 www.emea.lambda.tdk.com/de



TDK-Lambda (China) Electronics Co. Ltd.
 Tel: +86 21 6485-0777
 tlc.powersolutions@tdk.com
 www.lambda.tdk.com.cn



Austria Sales Office
 Tel: +43 2256 655 84
 tlg.at-powersolutions@tdk.com
 www.emea.lambda.tdk.com/at



TDK-Lambda Singapore Pte Ltd.
 Tel: +65 6251 7211
 tfs.marketing@tdk.com
 www.sg.lambda.tdk.com



Switzerland Sales Office
 Tel: +41 44 850 53 53
 tlg.ch-powersolutions@tdk.com
 www.emea.lambda.tdk.com/ch



TDK India Private Limited, Power Supply Division
 Tel: +91 80 4039-0660
 mathew.philip@tdk.com
 www.sg.lambda.tdk.com



TDK-Lambda Europe GmbH
 Tel: +45 3222 8086
 tlg.dk-powersolutions@tdk.com
 www.emea.lambda.tdk.com/dk



TDK-Lambda UK Ltd.
 Tel: +44 (0) 12 71 85 66 66
 tlu.powersolutions@tdk.com
 www.emea.lambda.tdk.com/uk



TDK-Lambda Ltd.
 Tel: +9 723 902 4333
 tli.powersolutions@tdk.com
 www.emea.lambda.tdk.com/il-en

