

SHARP

Be Original.

For Your Creative Products

LASER DIODES

Catalog

March 2024

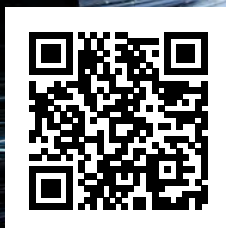
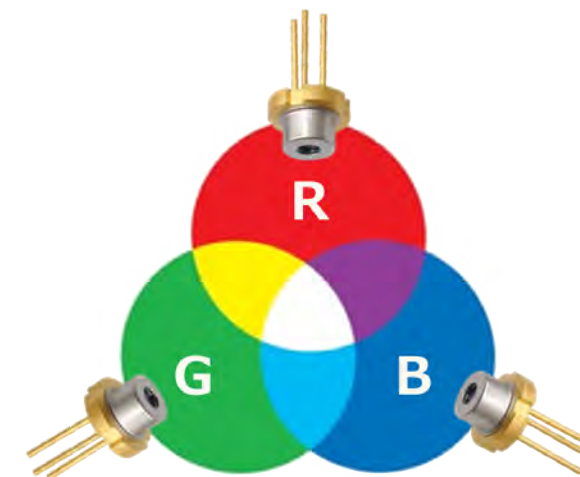

<https://global.sharp/products/device/>

LASER Diode Lineup

Precautions regarding laser

[Click](#)

Output / Wavelength deployment

[Click](#) on your desired wavelength band.

Package deployment

[Click](#) on your preferred package.

[Φ 9.0 CAN](#) [Φ 5.6 CAN](#) [Φ 3.8 CAN](#) [Φ 3.3 CAN](#) [T1.8mm Frame](#)

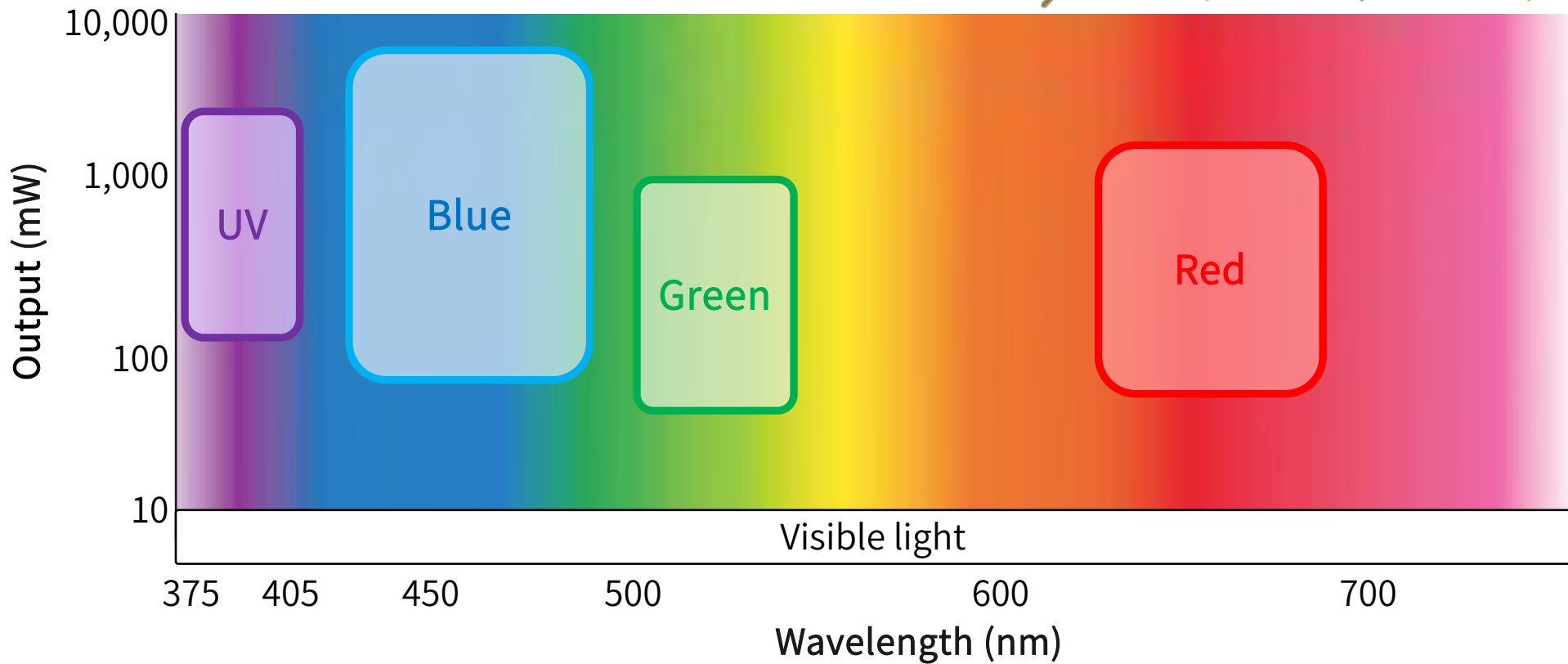

Wavelength Lineup





○ New product ● Under development

Model name [mode] ^{*4}			Wavelength λ_p (nm)	Characteristics (T _c =25°C)										Absolute maximum rating ^{*1}			Package (mm)	Monitor PD (Built-in:○)	
				Po (mW)	I _{th} (mA)	I _{op} (mA)	V _{op} (V)	η_d (mW/mA)	(Peak) λ_p (nm)	Emitter width (μ m)	FFP		Po (mW)	I _{op} (mA)	Top (°C)				
											$\theta_{//}$ (°)	θ_{\perp} (°)							
○	GH0382AA2G	MM	PDF	380	200	200	325	4.4	-	380	7	15	36	*3	210	-	0 to +30	ϕ 5.6	-
	GH0393AA2G	MM	PDF	395	300	150	310	4.4	1.8	395	7	13	44	*3	350	-	0 to +30	ϕ 5.6	-
	GH0401FA2G	SM	PDF	405	150	40	130	5.0	1.7	405	1.25	9	19	*2	155	-	-10 to +75	ϕ 5.6	-
	GH0401FA2K	SM	PDF	405	150	40	130	5.0	1.7	405	1.25	9	19	*2	155	-	-10 to +75	ϕ 5.6	○
	GH0406AA2G	MM	PDF	405	600	120	420	4.4	2.0	405	7	16	38	*3	700	-	0 to +30	ϕ 5.6	-
○	GH04V01A2GC	MM	PDF	405	1000	150	650	5.0	2.0	405	10	16	40	*3	1100	-	0 to +30	ϕ 5.6	-
●	GH04V01B2GC	MM	Under Construction	405	1300	(160)	(825)	(4.0)	-	405	15	(7.5)	(42)	*3	1400	-	0 to +30	ϕ 5.6	-
○	GH04V03Z9G	MM	PDF	405	3000	450	1800	4.0	2.0	405	30	8	40	*3	-	2000	0 to +30	ϕ 9.0	-
	GH04W10A2GC	MM	PDF	406	300	140	325	4.5	1.8	406	7	14	41	*3	350	-	0 to +50	ϕ 5.6	-

*1 The absolute maximum rating is a limit that must not be exceeded under any operating or test conditions.

*2 Overall width angle at 1/2 of peak intensity

*3 Overall width angle at 1/e² of peak intensity

*4 MM: Multimode, SM: Single mode

※ Please contact us for combinations of packages and characteristics other than the above.





○ New product ● Under development

Model name [mode] ^{*4}			Wavelength λ_p (nm)	Characteristics (T _c =25°C)										Absolute maximum rating ^{*1}			Package (mm)	Monitor PD (Built-in:○)
				P _o (mW)	I _{th} (mA)	I _{op} (mA)	V _{op} (V)	η_d (mW/mA)	(Peak) λ_p (nm)	Emitter width (μ m)	FFP		P _o (mW)	I _{op} (mA)	Top (°C)			
											$\theta_{//}$ (°)	θ_{\perp} (°)						
● GH04I01A2G	MM	PDF	425	1500	120	850	4.2	-	425	15	8	47	*3	1600	-	0 to +30	φ5.6	-
○ GH04C06R9G	MM	PDF	430	6000	300	3000	4.2	2.0	430	47	7	45	*3	-	3300	0 to +60	φ9.0	-
○ GH04C07W9G	MM	PDF	435	7000	360	4000	4.3	1.9	435	60	8	47	*3	-	4200	0 to +60	φ9.0	-
	SM	PDF	450	80	22	84	5.1	1.3	450	1.25	10	24	*2	85	-	-10 to +70	φ5.6	-
	SM	PDF	450	90	28	100	5.2	1.3	450	1.25	9	24	*2	95	-	-10 to +50	φ3.8	-
	MM	PDF	450	1800	110	1100	4.1	1.8	450	15	7	26	*2	2000	-	-10 to +50	φ5.6	-
	MM	PDF	450	3500	260	2100	4.4	1.9	450	30	9	47	*3	-	2800	0 to +60	φ9.0	-
○ GH04C05U9G	MM	PDF	450	5000	300	2950	4.1	1.8	450	47	9	46	*3	-	3200	0 to +60	φ9.0	-
	SM	PDF	487	50	40	105	6.0	0.8	487	1.55	8	23	*2	55	-	-10 to +60	φ5.6	-
	SM	PDF	498	80	30	120	6.0	0.6	498	1.85	7	22	*2	85	-	-10 to +60	φ3.8	○

*1 The absolute maximum rating is a limit that must not be exceeded under any operating or test conditions. *2 Overall width angle at 1/2 of peak intensity

*3 Overall width angle at 1/e² of peak intensity *4 MM: Multimode, SM: Single mode

※ Please contact us for combinations of packages and characteristics other than the above.

SHARP Green Laser Diode



Contact



○ New product ● Under development

Model name [mode] ^{*4}			Wavelength λ_p (nm)	Characteristics (T _c =25°C)										Absolute maximum rating ^{*1}			Package (mm)	Monitor PD (Built-in:○)
				P _o (mW)	I _{th} (mA)	I _{op} (mA)	V _{op} (V)	η_d (mW/mA)	(Peak) λ_p (nm)	Emitter width (μ m)	FFP		P _o (mW)	I _{op} (mA)	Top (°C)			
											$\theta_{//}$ (°)	θ_{\perp} (°)						
GH05030H2K	SM	PDF	505	30	30	75	6.0	0.7	505	1.8	8	23	*2	35	-	-10 to +60	ϕ 5.6	○
● GH05230H1G	SM	PDF	518	30	25	75	6.2	0.6	518	1.8	7.5	22	*2	35	-	-10 to +60	ϕ 5.6	-
GH15230H8C	SM	PDF	518	30	25	75	6.2	0.6	518	1.8	7.5	22	*2	35	-	-10 to +60	t1.8	-
GH05210H2KC	SM	PDF	520	10	25	35	5.8	0.7	520	1.8	7	22	*2	15	-	-10 to +60	ϕ 5.6	○
○ GH05210H5K	SM	PDF	520	10	25	35	5.8	0.7	520	1.8	7	22	*2	15	-	-10 to +70	ϕ 3.8	○
GH05230H2KC	SM	PDF	520	30	25	70	6.5	0.7	520	1.8	7	22	*2	35	-	-10 to +60	ϕ 5.6	○
GH05250F2K	SM	PDF	520	50	40	100	5.9	0.7	520	1.85	7	22	*2	55	-	-10 to +60	ϕ 5.6	○
GH05280E2KC	SM	PDF	520	80	50	150	6.5	0.8	520	1.85	7	23	*2	85	-	-10 to +60	ϕ 5.6	○
GH05280E5K	SM	PDF	520	80	65	180	6.5	0.7	520	1.85	7	23	*2	85	-	-10 to +60	ϕ 3.8	○
GH05290A5G	SM	PDF	520	90	60	185	6.8	0.7	520	1.85	7	23	*2	95	-	-10 to +50	ϕ 3.8	-
GH0521DE2G	SM	PDF	520	130	70	270	6.7	0.7	520	1.8	8	22	*2	135	-	-10 to +60	ϕ 5.6	-
GH0521DE5G	SM	PDF	520	130	70	270	6.7	0.7	520	1.8	8	22	*2	135	-	-10 to +50	ϕ 3.8	-
GH0523AD2G	MM	PDF	520	300	100	500	5.2	0.8	520	15	7	23	*2	-	850	0 to +60	ϕ 5.6	-
GH05C01B9G	MM	PDF	520	1000	210	1400	5.2	0.9	520	15	8	41	*3	-	1800	0 to +60	ϕ 9.0	-

*1 The absolute maximum rating is a limit that must not be exceeded under any operating or test conditions. *2 Overall width angle at 1/2 of peak intensity

*3 Overall width angle at 1/e² of peak intensity *4 MM: Multimode, SM: Single mode

※ Please contact us for combinations of packages and characteristics other than the above.



○ New product ● Under development

Model name [mode] ^{*4}			Wavelength λ_p (nm)	Characteristics (T _c =25°C)										Absolute maximum rating ^{*1}			Package (mm)	Monitor PD (Built-in:○)
				P _o (mW)	I _{th} (mA)	I _{op} (mA)	V _{op} (V)	η_d (mW/mA)	(Peak) λ_p (nm)	Emitter width (μ m)	FFP		P _o (mW)	I _{op} (mA)	Top (°C)			
											$\theta_{//}$ (°)	θ_{\perp} (°)						
GH06330A2G	SM	PDF	638	30	30	50	2.3	1.4	638	-	7	16	*2	30	-	-10 to +60	ϕ 5.6	-
GH1631AA8C	SM	PDF	638	100	50	130	2.5	1.2	638	-	8	15	*2	100	-	-10 to +60	t1.8	-
GH0631CA5GC	SM	PDF	638	120	50	150	2.5	1.2	638	-	8	15	*2	120	-	-10 to +50	ϕ 3.8	-
GH0631IA5G	SM	PDF	638	150	60	190	2.5	1.2	638	-	7.5	15	*2	185	-	-10 to +60	ϕ 3.8	-
GH0637AA2G	MM	PDF	638	700	110	810	2.5	1.0	638	-	16	35	*2	702	-	-10 to +30	ϕ 5.6	-
● GH0631IB2GC	SM	PDF	639	180	55	215	2.7	1.2	639	-	8	15	*2	185	-	-10 to +60	ϕ 5.6	-
● GH06C01A9G	MM	PDF	640	1200	350	1400	2.3	1.2	640	80	11	35	*2	1210	1600	0 to +45	ϕ 9.0	-
● GH0651IA2GC	SM	PDF	650	180	55	200	2.6	1.2	650	-	8	12.5	*2	185	-	-10 to +70	ϕ 5.6	-
GH06510F4AK	SM	PDF	660	7	17	26	2.2	0.9	660	-	13	28	*2	10	-	-10 to +70	ϕ 3.3	○
GH06610A2KC	SM	PDF	660	10	15	24	2.2	1.1	660	-	12	33	*2	12	-	-40 to +90	ϕ 5.6	○
GH06P25A2CC	SM	PDF	660	95	40	122	2.4	1.1	660	-	10	15.5	*2	100	-	-10 to +70	ϕ 5.6	-
GH16P32B8C	SM	PDF	661	90	42	120	2.3	1.2	661	-	9.3	15	*2	100	-	-10 to +70	t1.8	-

*1 The absolute maximum rating is a limit that must not be exceeded under any operating or test conditions. *2 Overall width angle at 1/2 of peak intensity

*3 Overall width angle at 1/e² of peak intensity *4 MM: Multimode, SM: Single mode

※ Please contact us for combinations of packages and characteristics other than the above.

SHARP 2 Wavelength Laser Diode



Contact



○ New product ● Under development

Model name [mode] ^{*4}			Wavelength λ_p (nm)	Characteristics (Tc=25°C)										Absolute maximum rating ^{*1}			Package (mm)	Monitor PD (Built-in:○)
				Po (mW)	Ith (mA)	Iop (mA)	Vop (V)	η_d (mW/mA)	(Peak) λ_p (nm)	Emitter width (μ m)	FFP		Po (mW)	Iop (mA)	Top (°C)			
											$\theta_{//}$ (°)	θ_{\perp} (°)						
GH33235A8CN (Two-Wavelength)	SM	PDF	661	90	50	134	2.4	1.1	661	-	8-11.5	13.5-19	*2	90	-	-10 to +85	t1.8	-
			785	150	53	215	2.4	0.9	785		7-10.5	13-18		160				
GH33540D8C5 (Two-Wavelength)	SM	PDF	661	120	68	189	2.5	1.0	661	-	8.5-11.5	14-19	*2	125	-	-10 to +80	t1.8	-
			785	150	55	230	2.4	0.9	785		7-10.5	13-18		200				

*1 The absolute maximum rating is a limit that must not be exceeded under any operating or test conditions. *2 Overall width angle at 1/2 of peak intensity

*3 Overall width angle at 1/e² of peak intensity *4 MM: Multimode, SM: Single mode

※ Please contact us for combinations of packages and characteristics other than the above.

Package Lineup

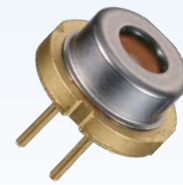

Φ 9.0 CAN



Φ 5.6 CAN



Φ 3.8 CAN



Φ 3.3 CAN



T1.8mm Frame

SHARP Laser Diode



φ9.0mm TO-CAN Package

Contact



○ New product ● Under development

Model name [mode] ^{*4}	Wavelength λ _p (nm)	Characteristics (T _c =25°C)											Absolute maximum rating ^{*1}			Monitor PD (Built-in:○)	
		P _o (mW)	I _{th} (mA)	I _{op} (mA)	V _{op} (V)	η _d (mW/ mA)	(Peak) λ _p (nm)	Emitter width (μm)	FFP		P _o (mW)	I _{op} (mA)	Top (°C)				
									θ _{//} (°)	θ _⊥ (°)							
○ GH04V03Z9G	MM	PDF	405	3000	450	1800	4.0	2.0	405	30	8	40	*3	-	2000	0 to +30	-
○ GH04C06R9G	MM	PDF	430	6000	300	3000	4.2	2.0	430	47	7	45	*3	-	3300	0 to +60	-
○ GH04C07W9G	MM	PDF	435	7000	360	4000	4.3	1.9	435	60	8	47	*3	-	4200	0 to +60	-
○ GH04C03Z9G	MM	PDF	450	3500	260	2100	4.4	1.9	450	30	9	47	*3	-	2800	0 to +60	-
○ GH04C05U9G	MM	PDF	450	5000	300	2950	4.1	1.8	450	47	9	46	*3	-	3200	0 to +60	-
○ GH05C01B9G	MM	PDF	520	1000	210	1400	5.2	0.9	520	15	8	41	*3	-	1800	0 to +60	-
● GH06C01A9G	MM	PDF	640	1200	350	1400	2.3	1.2	640	80	11	35	*2	1210	1600	0 to +45	-

*1 The absolute maximum rating is a limit that must not be exceeded under any operating or test conditions.

*2 Overall width angle at 1/2 of peak intensity

*3 Overall width angle at 1/e² of peak intensity

*4 MM: Multimode, SM: Single mode

※ Please contact us for combinations of packages and characteristics other than the above.



SHARP Laser Diode



φ5.6mm TO-CAN Package

Contact



○ New product ● Under development

Model name [mode] ^{*4}			Wavelength λ _p (nm)	Characteristics (T _c =25°C)											Absolute maximum rating ^{*1}			Monitor PD (Built-in:○)
				P _o (mW)	I _{th} (mA)	I _{op} (mA)	V _{op} (V)	η _d (mW/ mA)	(Peak) λ _p (nm)	Emitter width (μm)	FFP		P _o (mW)	I _{op} (mA)	Top (°C)			
											θ _{//} (°)	θ _⊥ (°)						
● GH0382AA2G	MM	PDF	380	200	200	325	4.4	-	380	7	15	36	*3	210	-	0 to +30	-	
GH0393AA2G	MM	PDF	395	300	150	310	4.4	1.8	395	7	13	44	*3	350	-	0 to +30	-	
GH0401FA2G	SM	PDF	405	150	40	130	5.0	1.7	405	1.25	9	19	*2	155	-	-10 to +75	-	
GH0401FA2K	SM	PDF	405	150	40	130	5.0	1.7	405	1.25	9	19	*2	155	-	-10 to +75	○	
GH0406AA2G	MM	PDF	405	600	120	420	4.4	2.0	405	7	16	38	*3	700	-	0 to +30	-	
● GH04V01A2GC	MM	PDF	405	1000	150	650	5.0	2.0	405	10	16	40	*3	1100	-	0 to +30	-	
● GH04V01B2GC	MM	Under Construction	405	1300	(160)	(825)	(4.0)	-	405	15	(7.5)	(42)	*3	1400	-	0 to +30	-	
GH04W10A2GC	MM	PDF	406	300	140	325	4.5	1.8	406	7	14	41	*3	350	-	0 to +50	-	
● GH04I01A2G	MM	PDF	425	1500	120	850	4.2	-	425	15	8	47	*3	1600	-	0 to +30	-	
GH04580A2G	SM	PDF	450	80	22	84	5.1	1.3	450	1.25	10	24	*2	85	-	-10 to +70	-	
GH04C01B2G	MM	PDF	450	1800	110	1100	4.1	1.8	450	15	7	26	*2	2000	-	-10 to +50	-	
GH04850B2G	SM	PDF	487	50	40	105	6.0	0.8	487	1.55	8	23	*2	55	-	-10 to +60	-	

*1 The absolute maximum rating is a limit that must not be exceeded under any operating or test conditions.

*2 Overall width angle at 1/2 of peak intensity

*3 Overall width angle at 1/e² of peak intensity

*4 MM: Multimode, SM: Single mode

※ Please contact us for combinations of packages and characteristics other than the above.



<https://global.sharp/products/device/>

SHARP Laser Diode



φ5.6mm TO-CAN Package

Contact



○ New product ● Under development

Model name [mode] ^{*4}			Wavelength λ _p (nm)	Characteristics (T _c =25°C)										Absolute maximum rating ^{*1}			Monitor PD (Built-in:○)
				P _o (mW)	I _{th} (mA)	I _{op} (mA)	V _{op} (V)	η _d (mW/ mA)	(Peak) λ _p (nm)	Emitter width (μm)	FFP		P _o (mW)	I _{op} (mA)	Top (°C)		
											θ _{//} (°)	θ _⊥ (°)					
GH05030H2K	SM	PDF	505	30	30	75	6.0	0.7	505	1.8	8	23	*2	35	-	-10 to +60	○
● GH05230H1G	SM	PDF	518	30	25	75	6.2	0.6	518	1.8	7.5	22	*2	35	-	-10 to +60	-
GH05210H2KC	SM	PDF	520	10	25	35	5.8	0.7	520	1.8	7	22	*2	15	-	-10 to +60	○
GH05230H2KC	SM	PDF	520	30	25	70	6.5	0.7	520	1.8	7	22	*2	35	-	-10 to +60	○
GH05250F2K	SM	PDF	520	50	40	100	5.9	0.7	520	1.85	7	22	*2	55	-	-10 to +60	○
GH05280E2KC	SM	PDF	520	80	50	150	6.5	0.8	520	1.85	7	23	*2	85	-	-10 to +60	○
GH0521DE2G	SM	PDF	520	130	70	270	6.7	0.7	520	1.8	8	22	*2	135	-	-10 to +60	-
GH0523AD2G	MM	PDF	520	300	100	500	5.2	0.8	520	15	7	23	*2	-	850	0 to +60	-
GH06330A2G	SM	PDF	638	30	30	50	2.3	1.4	638	-	7	16	*2	30	-	-10 to +60	-
GH0637AA2G	MM	PDF	638	700	110	810	2.5	1.0	638	-	16	35	*2	702	-	-10 to +40	-
● GH0631IB2GC	SM	PDF	639	180	55	215	2.7	1.2	639	-	8	15	*2	185	-	-10 to +60	-
● GH0651IA2GC	SM	PDF	650	180	55	200	2.6	1.2	650	-	8	12.5	*2	185	-	-10 to +70	-
GH06610A2KC	SM	PDF	660	10	15	24	2.2	1.1	660	-	12	33	*2	12	-	-40 to +90	○
GH06P25A2CC	SM	PDF	660	95	40	122	2.4	1.1	660	-	10	15.5	*2	100	-	-10 to +70	-

*1 The absolute maximum rating is a limit that must not be exceeded under any operating or test conditions. *2 Overall width angle at 1/2 of peak intensity

*3 Overall width angle at 1/e² of peak intensity *4 MM: Multimode, SM: Single mode

※ Please contact us for combinations of packages and characteristics other than the above.

SHARP Laser Diode



φ3.8mm TO-CAN Package

Contact



○ New product ● Under development

Model name [mode] ^{*4}			Wavelength λ _p (nm)	Characteristics (T _c =25°C)										Absolute maximum rating ^{*1}			Monitor PD (Built-in:○)
				P _o (mW)	I _{th} (mA)	I _{op} (mA)	V _{op} (V)	η _d (mW/ mA)	(Peak) λ _p (nm)	Emitter width (μm)	FFP		P _o (mW)	I _{op} (mA)	Top (°C)		
											θ _{//} (°)	θ _⊥ (°)					
GH04590A5G	SM	PDF	450	90	28	100	5.2	1.3	450	1.25	9	24	*2	95	-	-10 to +50	-
GH04980E5K	SM	PDF	498	80	30	120	6.0	0.6	498	1.85	7	22	*2	85	-	-10 to +60	○
GH05210H5K	SM	PDF	520	10	25	35	5.8	0.7	520	1.8	7	22	*2	15	-	-10 to +70	○
GH05280E5K	SM	PDF	520	80	65	180	6.5	0.7	520	1.85	7	23	*2	85	-	-10 to +60	○
GH05290A5G	SM	PDF	520	90	60	185	6.8	0.7	520	1.85	7	23	*2	95	-	-10 to +50	-
GH0521DE5G	SM	PDF	520	130	70	270	6.7	0.7	520	1.8	8	22	*2	135	-	-10 to +50	-
GH0631CA5GC	SM	PDF	638	120	50	150	2.5	1.2	638	-	8	15	*2	120	-	-10 to +60	-
GH0631IA5G	SM	PDF	638	150	60	190	2.5	1.2	638	-	7.5	15	*2	185	-	-10 to +60	-

*1 The absolute maximum rating is a limit that must not be exceeded under any operating or test conditions.

*2 Overall width angle at 1/2 of peak intensity

*3 Overall width angle at 1/e² of peak intensity

*4 MM: Multimode, SM: Single mode

※ Please contact us for combinations of packages and characteristics other than the above.



SHARP Laser Diode



φ3.3mm TO-CAN Package

Contact



○ New product ● Under development

Model name [mode] ^{*4}			Wavelength λ _p (nm)	Characteristics (T _c =25°C)										Absolute maximum rating ^{*1}			Monitor PD (Built-in:○)
				P _o (mW)	I _{th} (mA)	I _{op} (mA)	V _{op} (V)	η _d (mW/ mA)	(Peak) λ _p (nm)	Emitter width (μm)	FFP		P _o (mW)	I _{op} (mA)	Top (°C)		
											θ _{//} (°)	θ _⊥ (°)					
GH06510F4AK	SM	PDF	660	7	17	26	2.2	0.9	660	-	13	28	*2	10	-	-10 to +70	○

*1 The absolute maximum rating is a limit that must not be exceeded under any operating or test conditions.

*2 Overall width angle at 1/2 of peak intensity

*3 Overall width angle at 1/e² of peak intensity

*4 MM: Multimode, SM: Single mode

※ Please contact us for combinations of packages and characteristics other than the above.





t1.8mm Frame

Contact



○ New product ● Under development

Model name [mode] ^{*4}			Wavelength λ_p (nm)	Characteristics (T _c =25°C)										Absolute maximum rating ^{*1}			Monitor PD (Built-in:○)
				P _o (mW)	I _{th} (mA)	I _{op} (mA)	V _{op} (V)	η_d (mW/ mA)	(Peak) λ_p (nm)	Emitter width (μ m)	FFP		P _o (mW)	I _{op} (mA)	Top (°C)		
											$\theta_{//}$ (°)	θ_{\perp} (°)					
GH15230H8C	SM	PDF	518	30	25	75	6.2	0.6	518	1.8	7.5	22	*2	35	-	-10 to +60	-
GH1631AA8C	SM	PDF	638	100	50	130	2.5	1.2	638	-	8	15	*2	100	-	-10 to +60	-
GH16P32B8C	SM	PDF	661	90	42	120	2.3	1.2	661	-	9.3	15	*2	100	-	-10 to +70	-
GH33235A8CN (Two-Wavelength)	SM	PDF	661	90	50	134	2.4	1.1	661	-	8-11.5	13.5-19	*2	90	-	-10 to +85	-
			785	150	53	215	2.4	0.9	785		7-10.5	13-18		160			
GH33540D8C5 (Two-Wavelength)	SM	PDF	661	120	68	189	2.5	1.0	661	-	8.5-11.5	14-19	*2	125	-	-10 to +80	-
			785	150	55	230	2.4	0.9	785		7-10.5	13-18		200			

*1 The absolute maximum rating is a limit that must not be exceeded under any operating or test conditions.

*2 Overall width angle at 1/2 of peak intensity

*3 Overall width angle at 1/e² of peak intensity

*4 MM: Multimode, SM: Single mode

※ Please contact us for combinations of packages and characteristics other than the above.





[← To the Wavelength](#)

[← To the Package](#)

[Contact](#)

φ5.6mm TO-CAN Package

March 2024

Characteristics

(Tc=25°C, CW)

Item	Conditions	Characteristic value (TYP.)
Wavelength (Peak)	Po=200mW	380nm
Output [Max]	—	200mW [210mW]
Threshold current	—	200mA
Operating current	Po=200mW	325mA
Operating voltage	Po=200mW	4.4V
Far Field (1/e ²)	Po=200mW	θ// 15°, θ⊥ 36°

Terminal connections	No.9
Package type	φ5.6

CW I-L, I-V Temperature

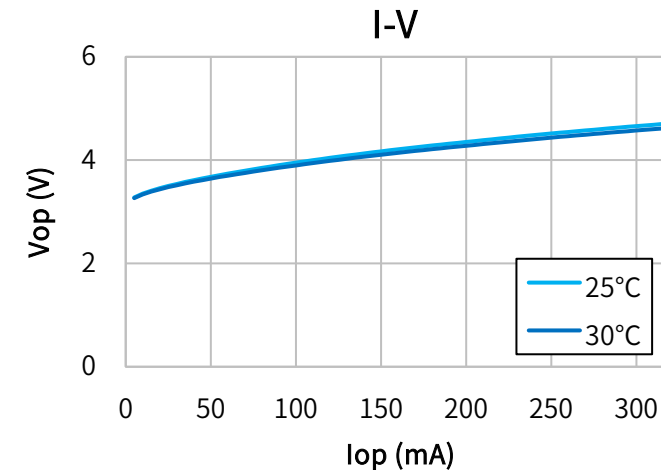
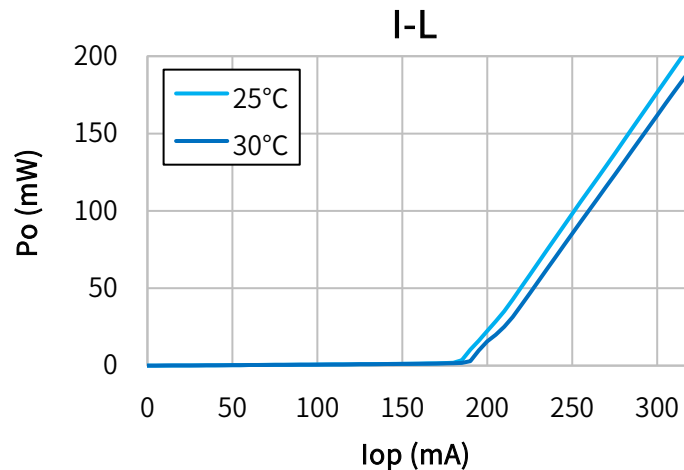

Far Field Pattern

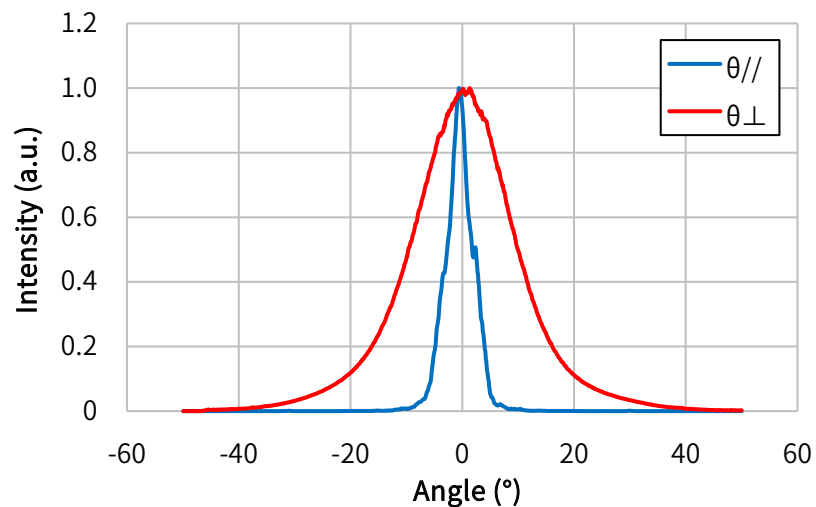

Near Field Pattern

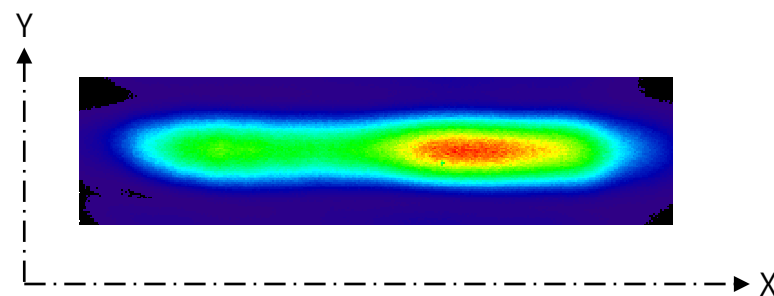

Emitter size

	FWHM (μm)	1/e (μm)	1/e ² (μm)
X	6.2	6.7	7.9
Y	0.7	0.9	1.2

X Profile

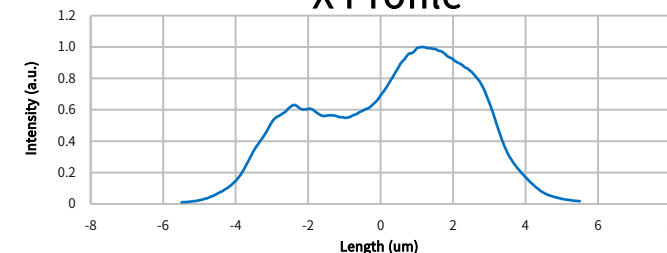

Y Profile

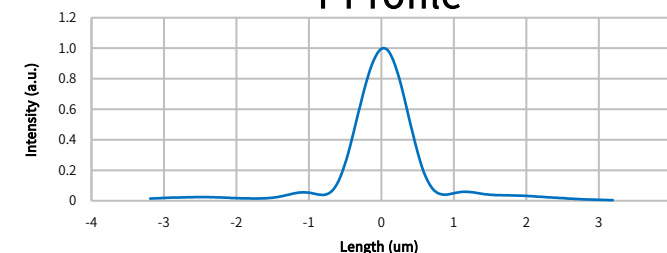



Characteristics

(Tc=25°C, CW)

Item	Conditions	Characteristic value (TYP.)
Wavelength (Peak)	Po=300mW	395nm
Output [Max]	—	300mW [350mW]
Threshold current	—	150mA
Operating current	Po=300mW	310mA
Operating voltage	Po=300mW	4.4V
Far Field (1/e ²)	Po=300mW	θ// 13°, θ⊥ 44°
Terminal connections		No.9
Package type		φ5.6

CW I-L, I-V Temperature

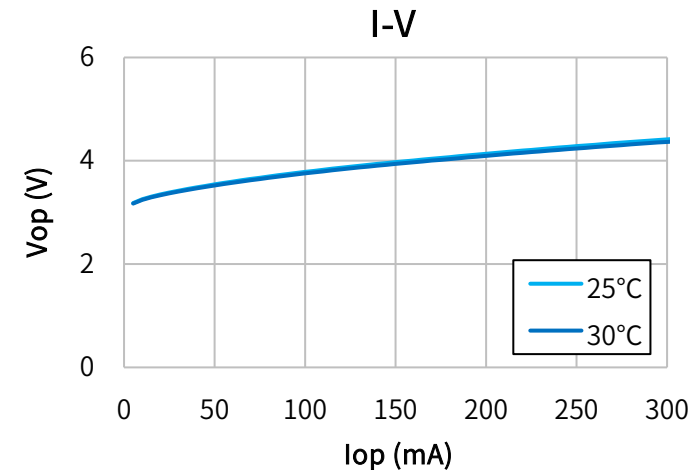
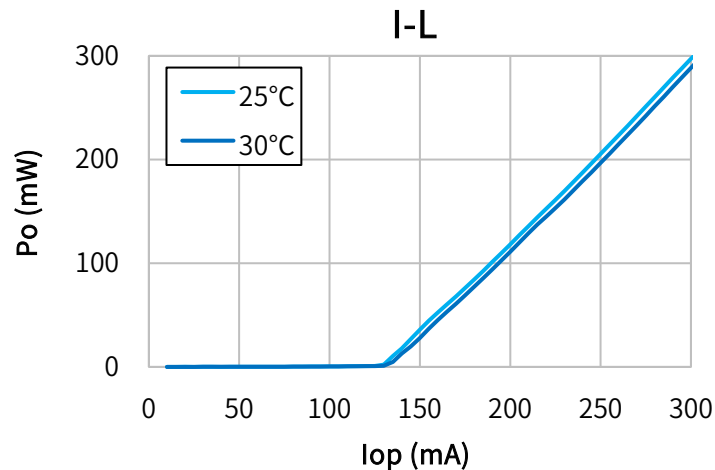

Far Field Pattern

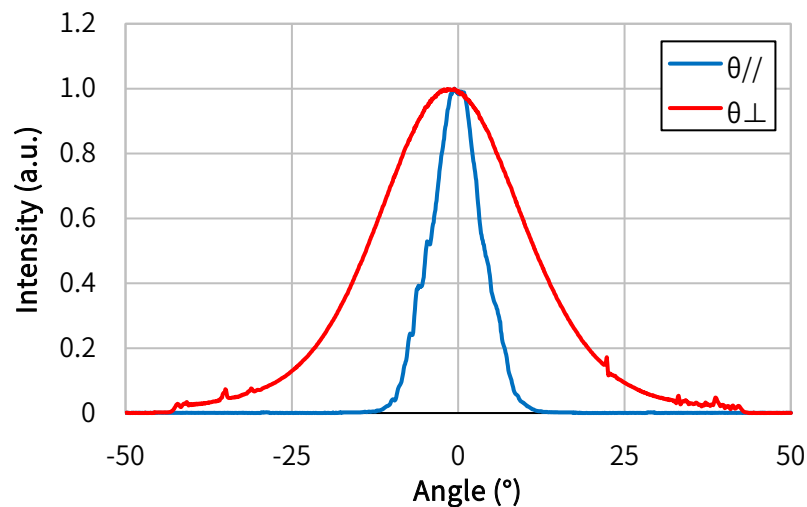

Near Field Pattern

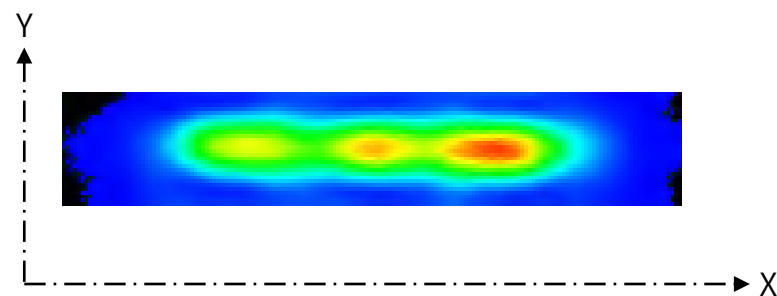

Emitter size

	FWHM (μm)	1/e (μm)	1/e ² (μm)
X	7.0	7.5	8.7
Y	0.9	1.1	1.5

X Profile

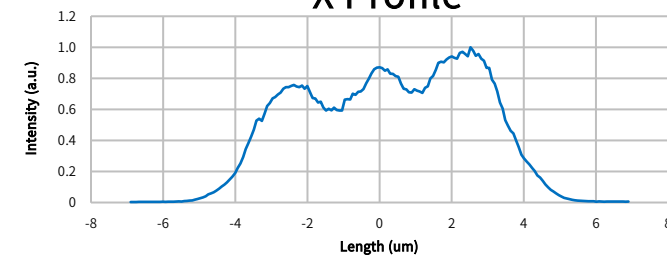

Y Profile

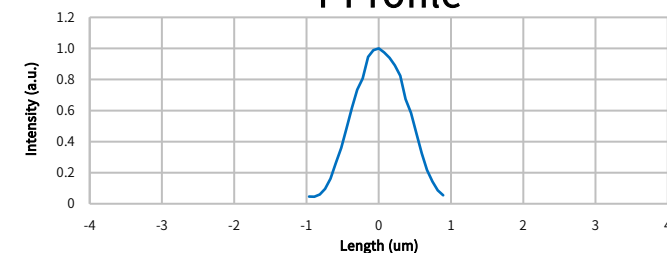



Characteristics

(T_c=25°C, CW)

Item	Conditions	Characteristic value (TYP.)
Wavelength (Peak)	Po=150mW	405nm
Output [Max]	—	150mW [155mW]
Threshold current	—	40mA
Operating current	Po=150mW	130mA
Operating voltage	Po=150mW	5.0V
Far Field (FWHM)	Po=150mW	θ// 9°, θ⊥ 19°

Terminal connections	No.8
Package type	φ5.6

CW I-L, I-V Temperature

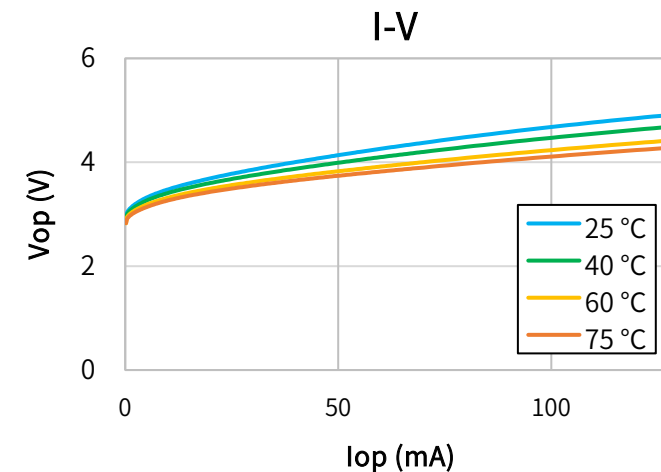
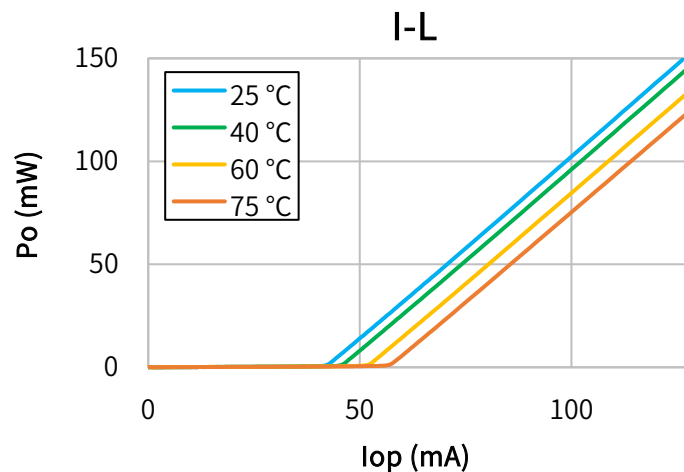

Far Field Pattern

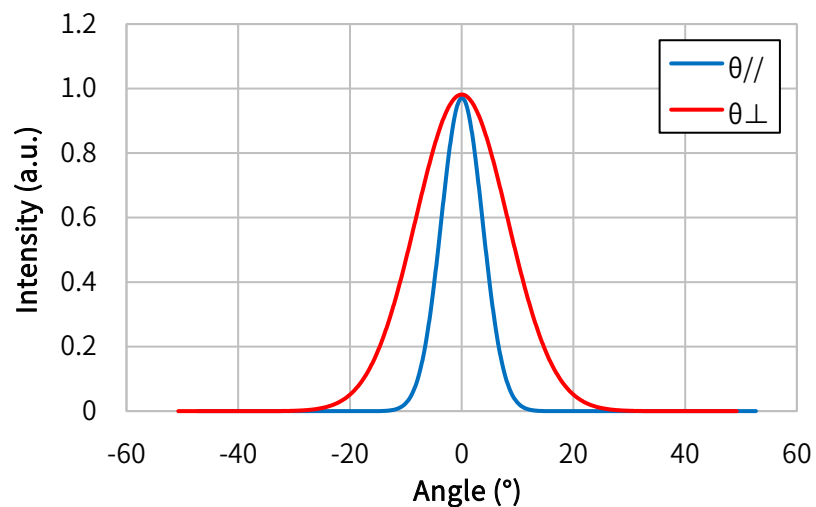

Near Field Pattern

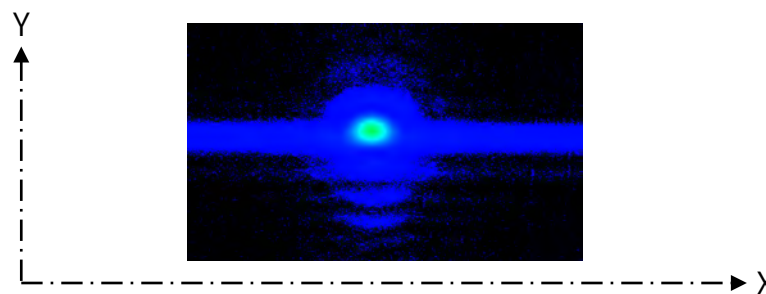

Emitter size

	FWHM (μm)	1/e (μm)	1/e ² (μm)
X	1.3	1.6	2.7
Y	0.8	1.0	1.4

X Profile

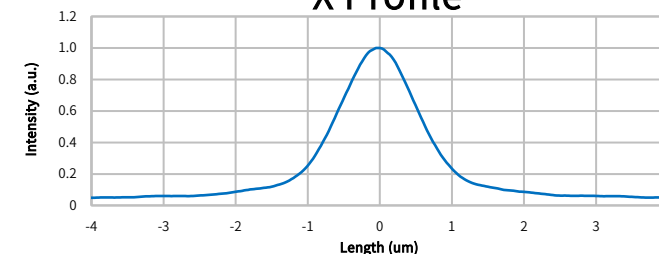

Y Profile

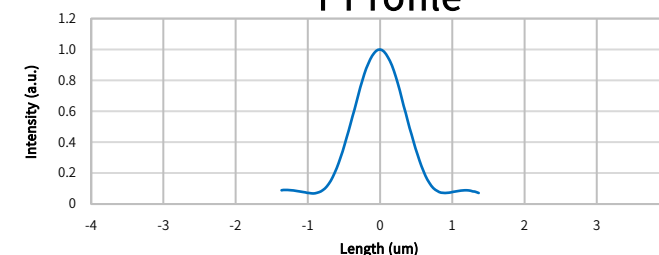



Characteristics

(Tc=25°C, CW)

Item	Conditions	Characteristic value (TYP.)
Wavelength (Peak)	Po=150mW	405nm
Output [Max]	—	150mW [155mW]
Threshold current	—	40mA
Operating current	Po=150mW	130mA
Operating voltage	Po=150mW	5.0V
Far Field (FWHM)	Po=150mW	$\theta_{//} 9^\circ, \theta_{\perp} 19^\circ$
Terminal connections		No.4
Package type		φ5.6

CW I-L, I-V Temperature

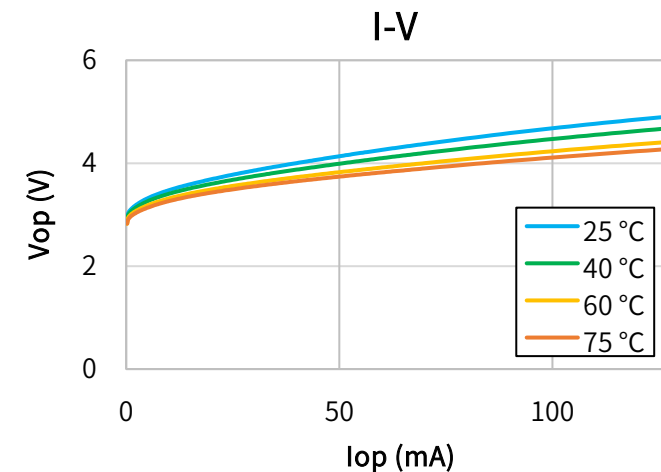
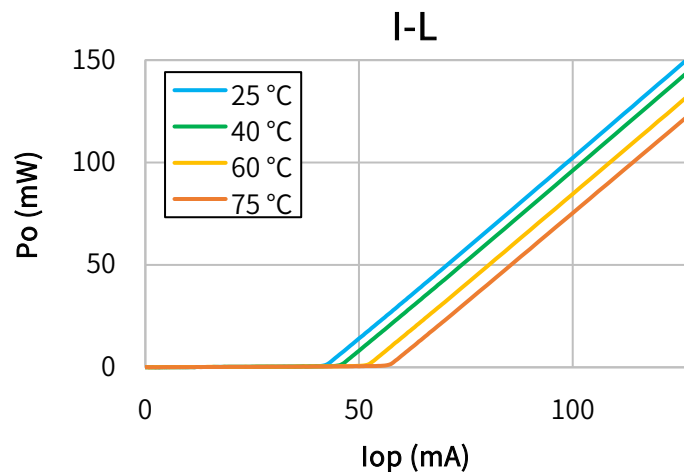

Far Field Pattern

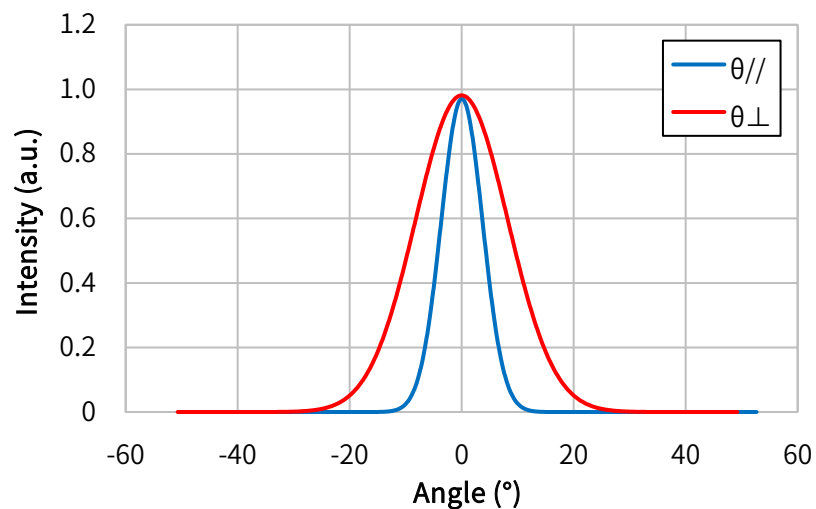

Near Field Pattern

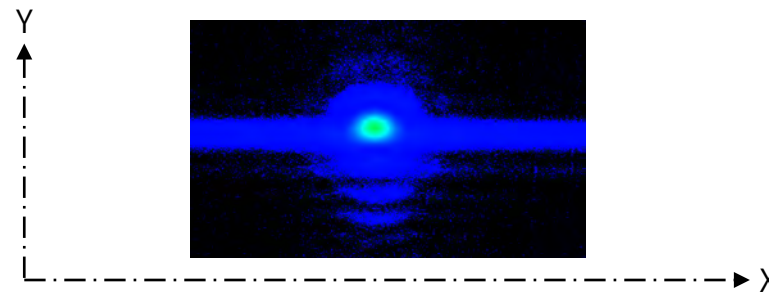

Emitter size

	FWHM (μm)	1/e (μm)	1/e ² (μm)
X	1.3	1.6	2.7
Y	0.8	1.0	1.4

X Profile

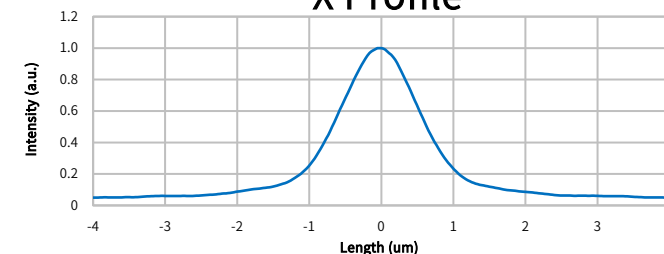

Y Profile

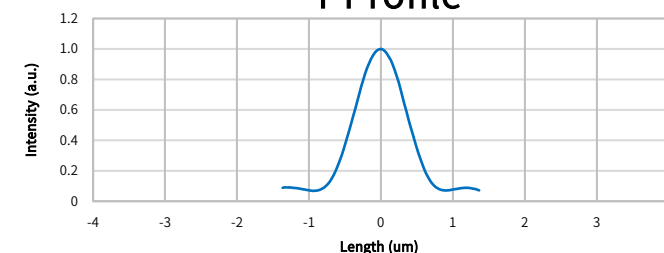



Characteristics

(Tc=25°C, CW)

Item	Conditions	Characteristic value (TYP.)
Wavelength (Peak)	Po=600mW	405nm
Output [Max]	—	600mW [700mW]
Threshold current	—	120mA
Operating current	Po=600mW	420mA
Operating voltage	Po=600mW	4.4V
Far Field (1/e ²)	Po=600mW	θ// 16°, θ⊥ 38°
Terminal connections	No.9	
Package type	φ5.6	

CW I-L, I-V Temperature

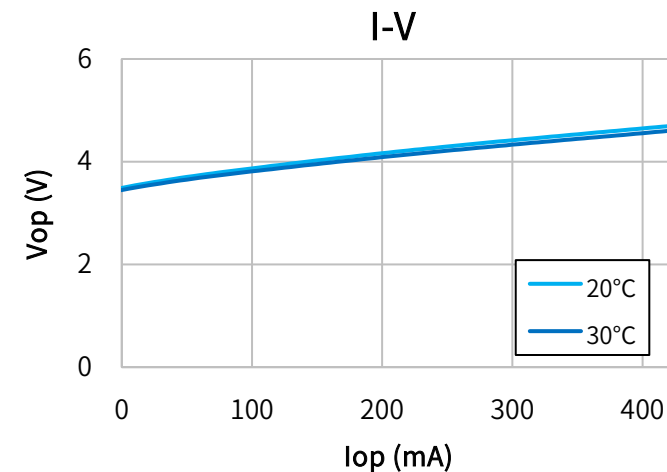
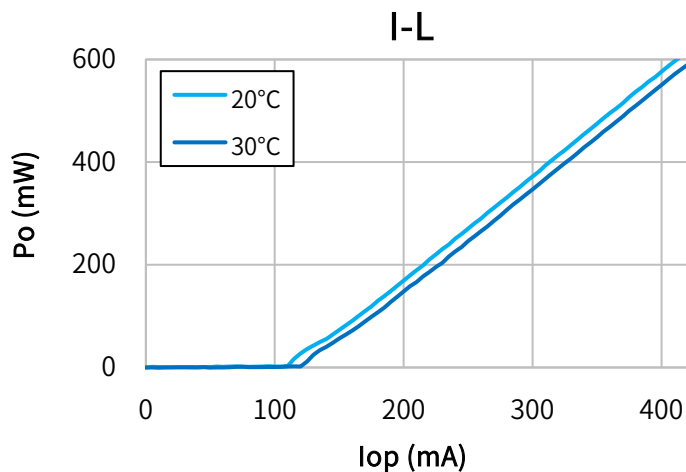

Far Field Pattern

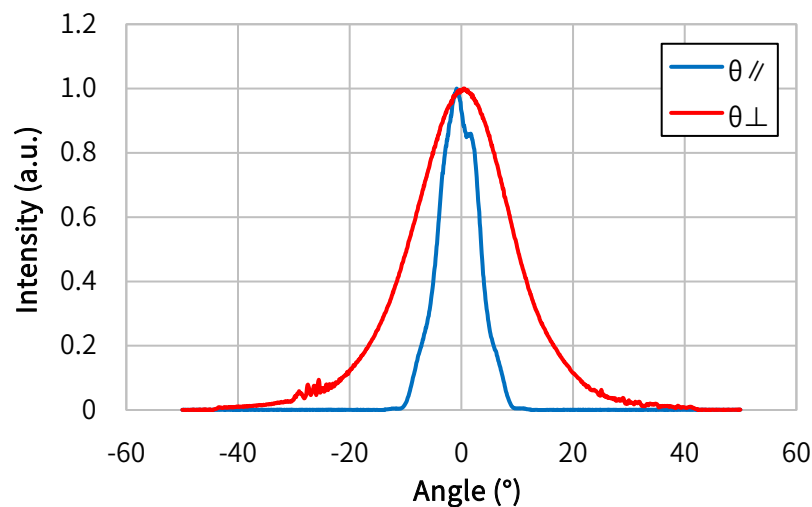

Near Field Pattern

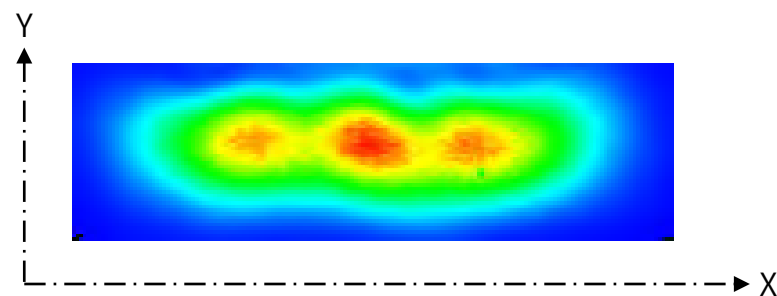

Emitter size

	FWHM (μm)	1/e (μm)	1/e ² (μm)
X	7.7	8.4	10.4
Y	1.8	2.2	3.3

X Profile

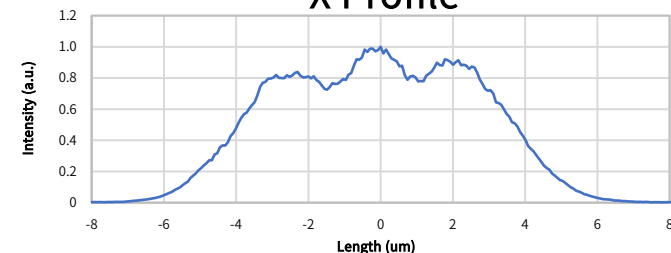

Y Profile

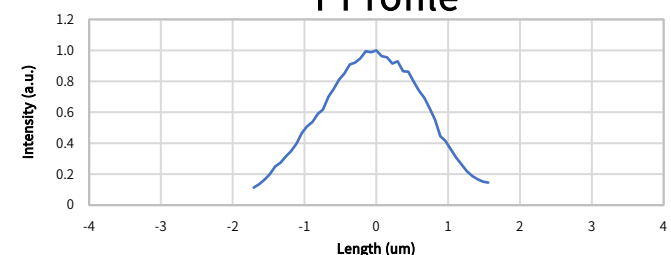



Characteristics

(Tc=25°C, CW)

Item	Conditions	Characteristic value (TYP.)
Wavelength (Peak)	Po=1000mW	405nm
Output [Max]	—	1000mW [1100mW]
Threshold current	—	150mA
Operating current	Po=1000mW	650mA
Operating voltage	Po=1000mW	5.0V
Far Field (1/e ²)	Po=1000mW	θ// 16°, θ⊥ 40°

Terminal connections	No.9
Package type	φ5.6

CW I-L, I-V Temperature

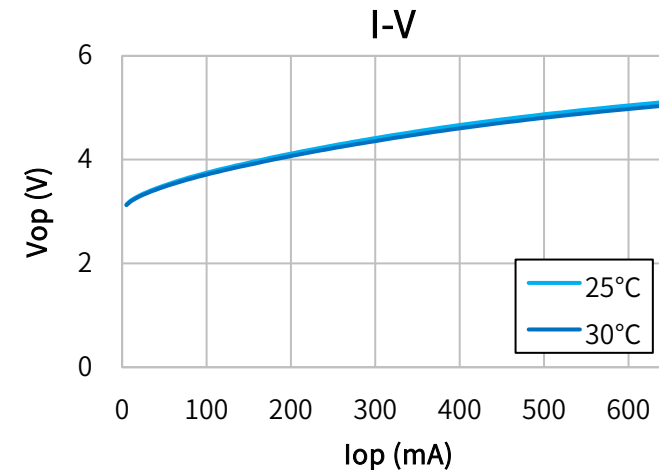
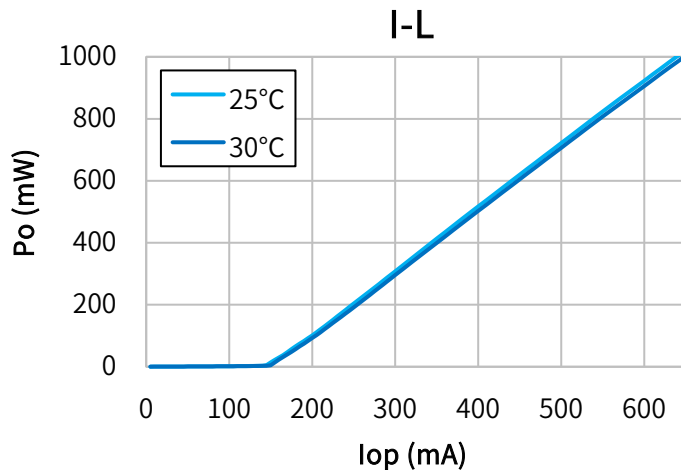

Far Field Pattern

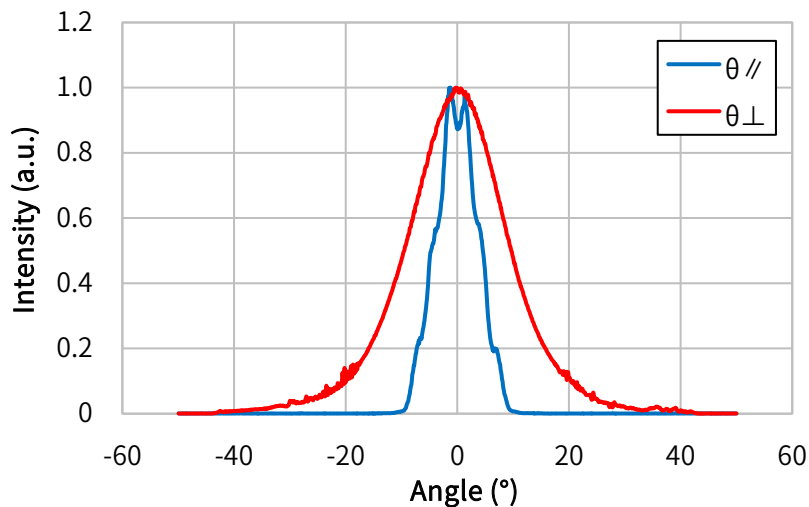

Near Field Pattern

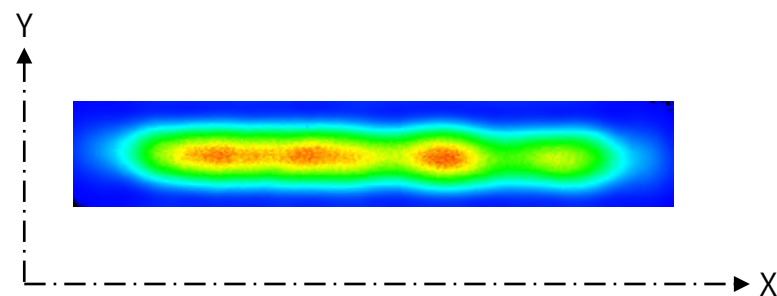

Emitter size

	FWHM (μm)	1/e (μm)	1/e ² (μm)
X	9.5	9.9	11.5
Y	0.9	1.1	1.5

X Profile

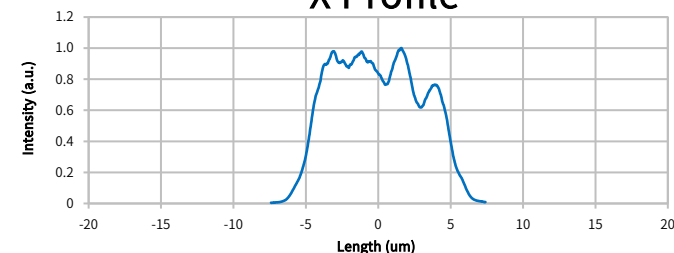

Y Profile

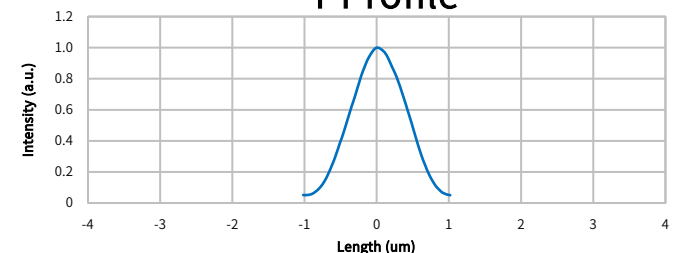



Characteristics

(Tc=25°C, CW)

Item	Conditions	Characteristic value (TYP.)
Wavelength (Peak)	Po=3000mW	405nm
Output	—	3000mW
Threshold current	—	450mA
Operating current	Po=3000mW	1800mA
Operating voltage	Po=3000mW	4.0V
Far Field (1/e ²)	Po=3000mW	θ// 8°, θ⊥ 40°
Terminal connections	No.13	
Package type	φ9.0	

CW I-L, I-V Temperature

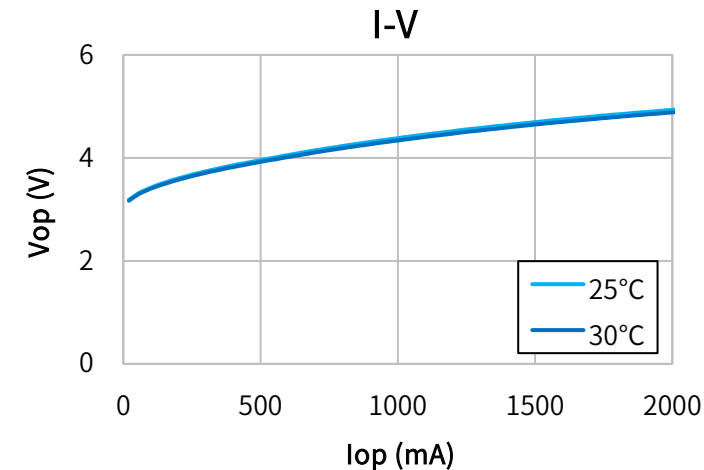
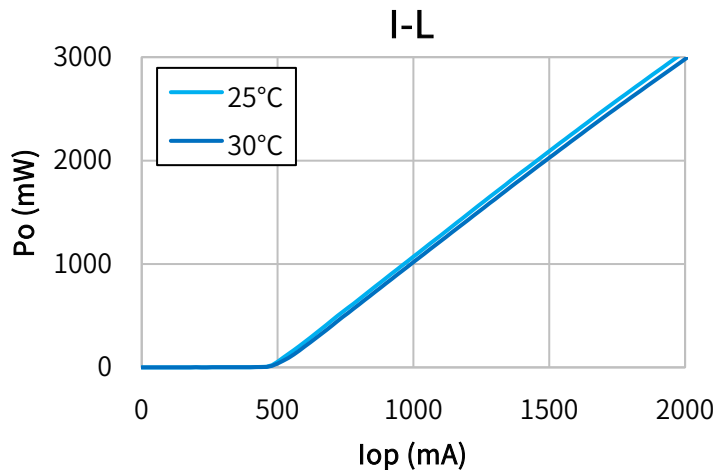

Far Field Pattern

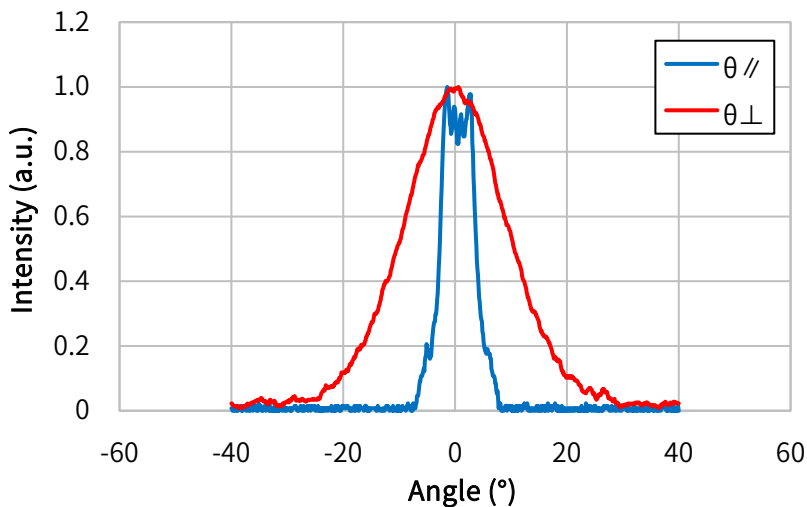

Near Field Pattern

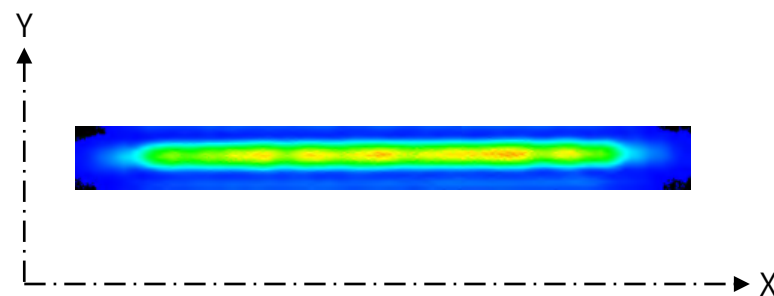

Emitter size

	FWHM (μm)	1/e (μm)	1/e ² (μm)
X	25.8	26.7	30.5
Y	1.1	1.2	1.7

X Profile

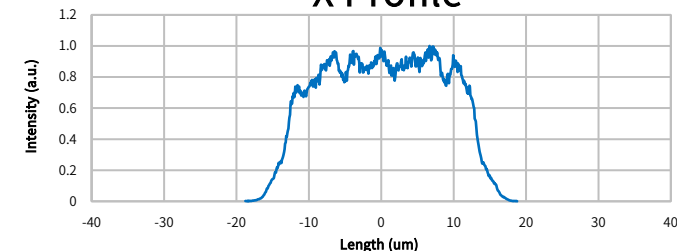

Y Profile

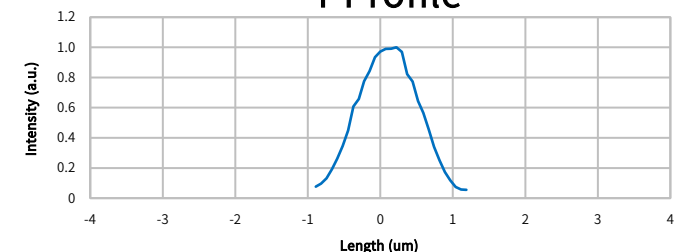



[← To the Wavelength](#)

[← To the Package](#)

[Contact](#)

Characteristics

(Tc=25°C, CW)

Item	Conditions	Characteristic value (TYP.)
Wavelength (Peak)	Po=300mW	406nm
Output [Max]	—	300mW [350mW]
Threshold current	—	140mA
Operating current	Po=300mW	325mA
Operating voltage	Po=300mW	4.5V
Far Field (1/e ²)	Po=300mW	θ// 14°, θ⊥ 41°

Terminal connections	No.9
Package type	φ5.6

Far Field Pattern

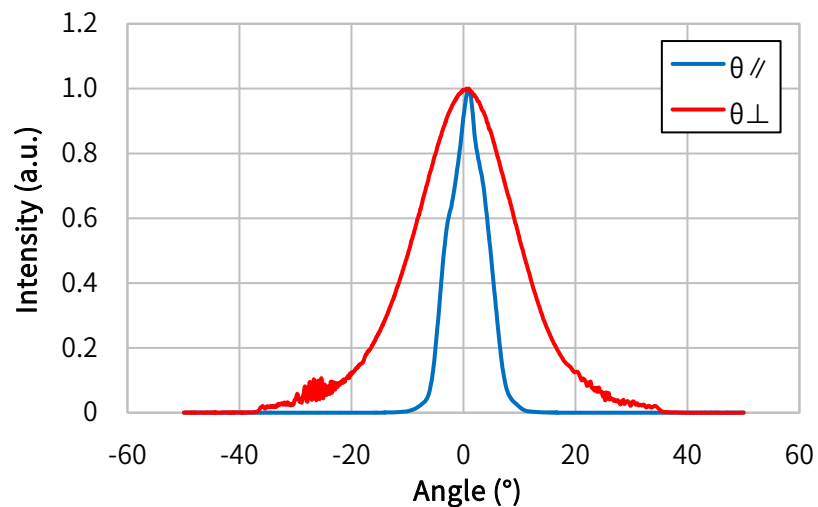

CW I-L, I-V Temperature

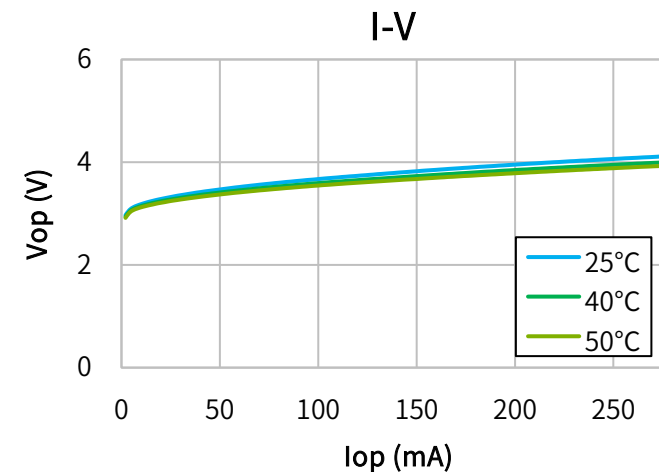
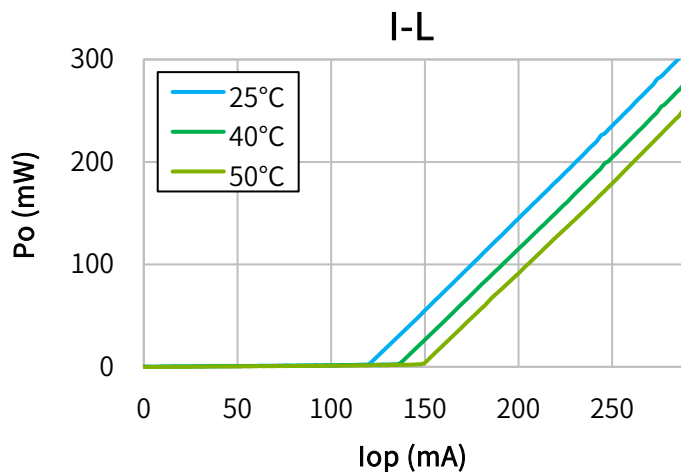

Near Field Pattern

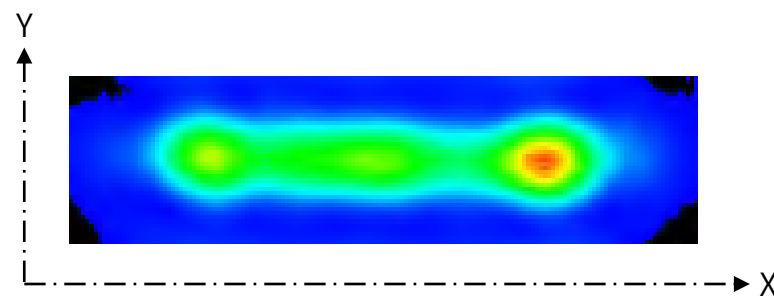

Emitter size

	FWHM (μm)	1/e (μm)	1/e ² (μm)
X	7.4	7.8	8.9
Y	1.1	1.3	1.8

X Profile

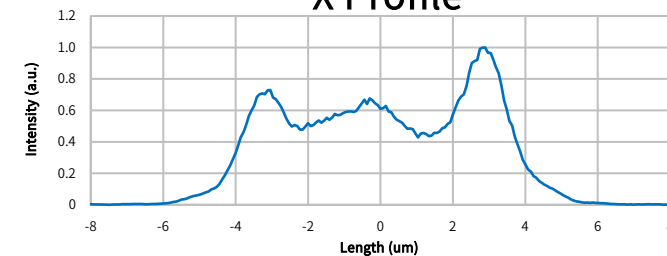

Y Profile

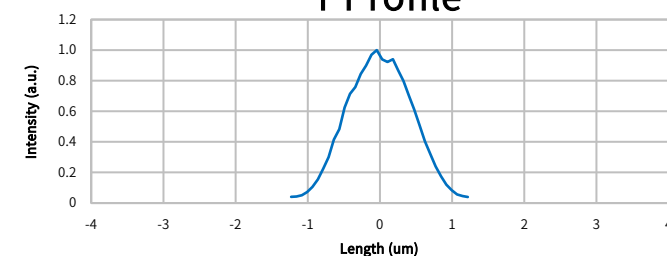



Characteristics

(Tc=25°C, CW)

Item	Conditions	Characteristic value (TYP.)
Wavelength (Peak)	Po=1500mW	425nm
Output [Max]	—	1500mW [1600mW]
Threshold current	—	120mA
Operating current	Po=1500mW	850mA
Operating voltage	Po=1500mW	4.2V
Far Field (1/e ²)	Po=1500mW	θ// 8°, θ⊥ 47°

Terminal connections	No.9
Package type	φ5.6

CW I-L, I-V Temperature

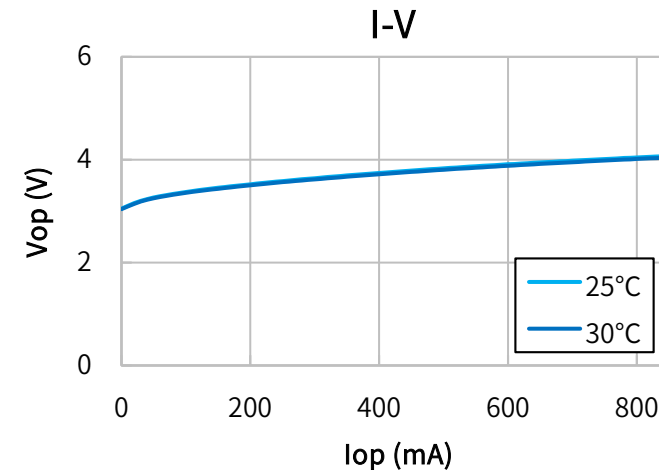
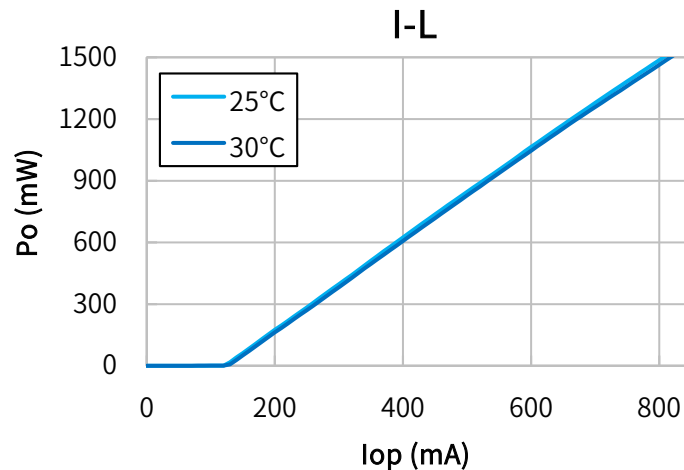

Far Field Pattern

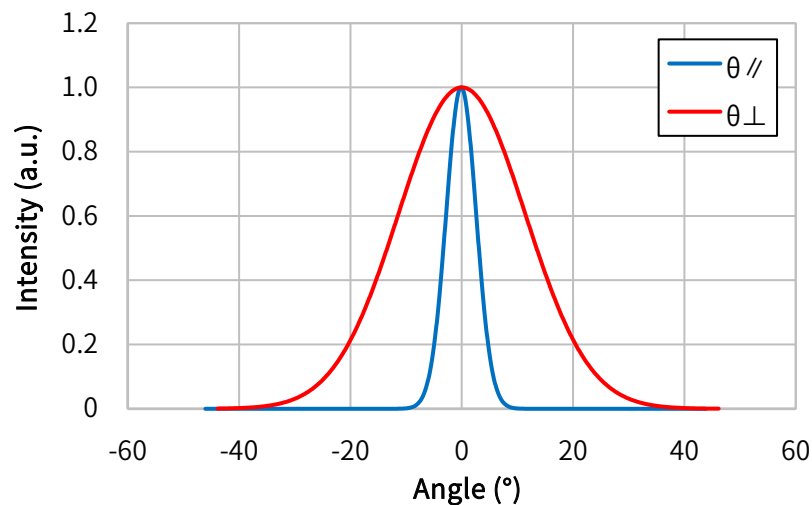

Near Field Pattern

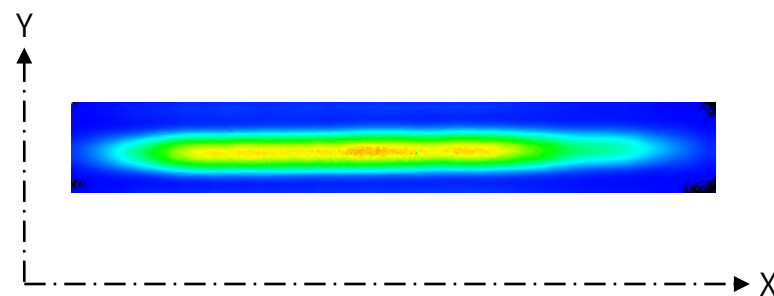

Emitter size

	FWHM (μm)	1/e (μm)	1/e ² (μm)
X	11.7	13.7	16.3
Y	0.8	1.0	1.4

X Profile

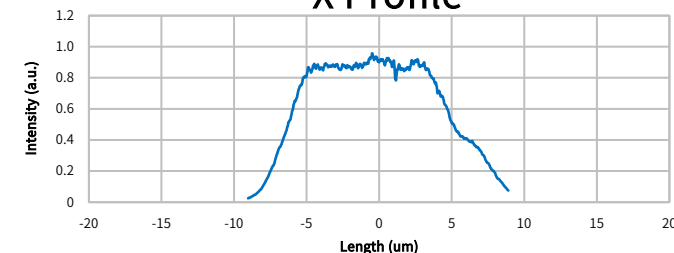

Y Profile

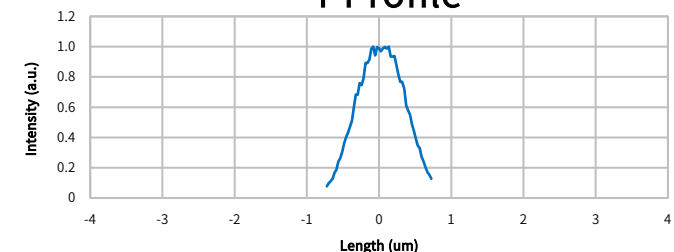



Characteristics

(Tc=25°C, CW)

Item	Conditions	Characteristic value (TYP.)
Wavelength (Peak)	Po=6000mW	430nm
Output	—	6000mW
Threshold current	—	300mA
Operating current	Po=6000mW	3000mA
Operating voltage	Po=6000mW	4.2V
Far Field (1/e ²)	Po=6000mW	θ// 7°, θ⊥ 45°
Terminal connections	No.13	
Package type	φ9.0	

CW I-L, I-V Temperature

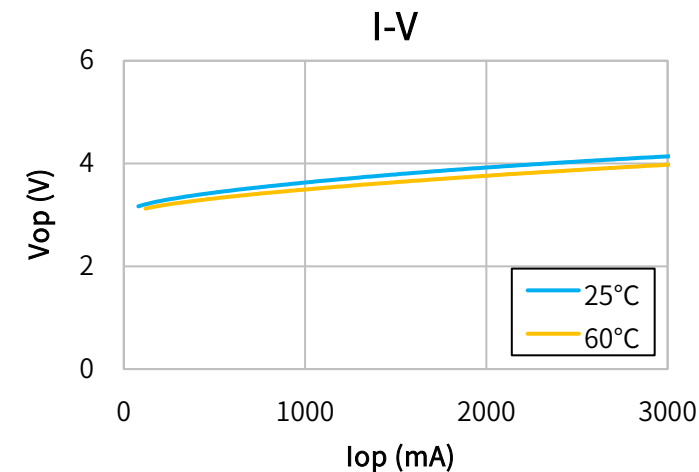
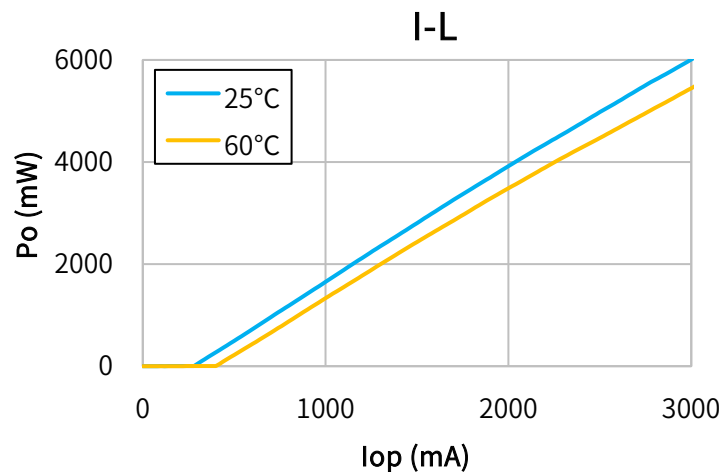

Far Field Pattern

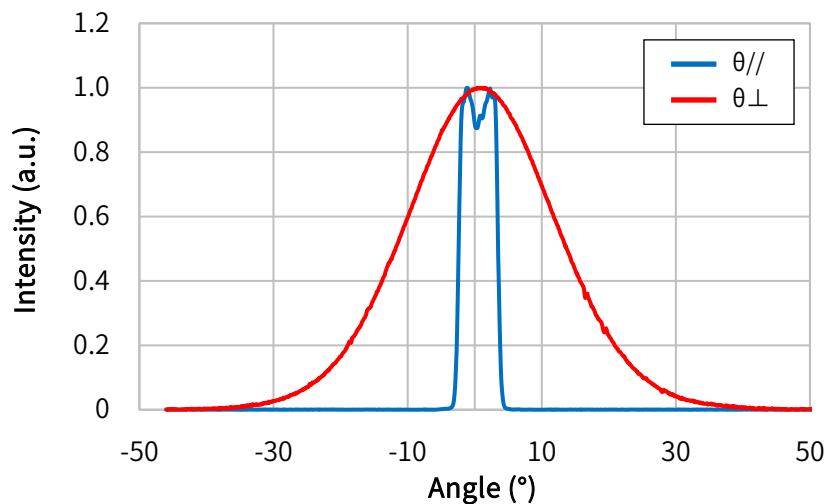

Near Field Pattern

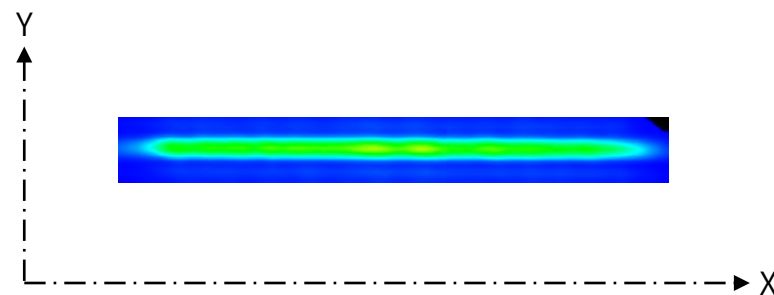

Emitter size

	FWHM (μm)	1/e (μm)	1/e ² (μm)
X	40.2	42.0	47.1
Y	1.4	1.6	1.7

X Profile

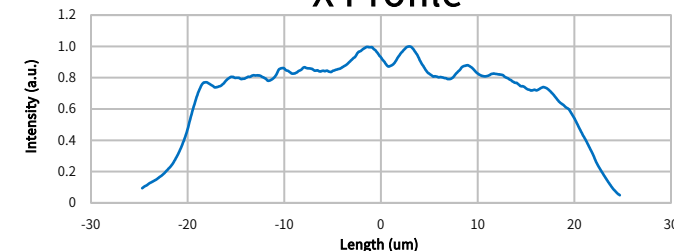

Y Profile

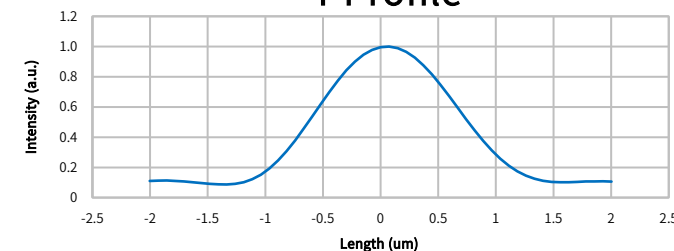



[To the Wavelength](#)

[To the Package](#)

[Contact](#)

Characteristics

(Tc=25°C, CW)

Item	Conditions	Characteristic value (TYP.)
Wavelength (Peak)	Po=7000mW	435nm
Output	—	7000 mW
Threshold current	—	360mA
Operating current	Po=7000mW	4000mA
Operating voltage	Po=7000mW	4.3V
Far Field (1/e ²)	Po=7000mW	θ// 8°, θ⊥ 47°
Terminal connections	No.13	
Package type	φ9.0	

CW I-L, I-V Temperature

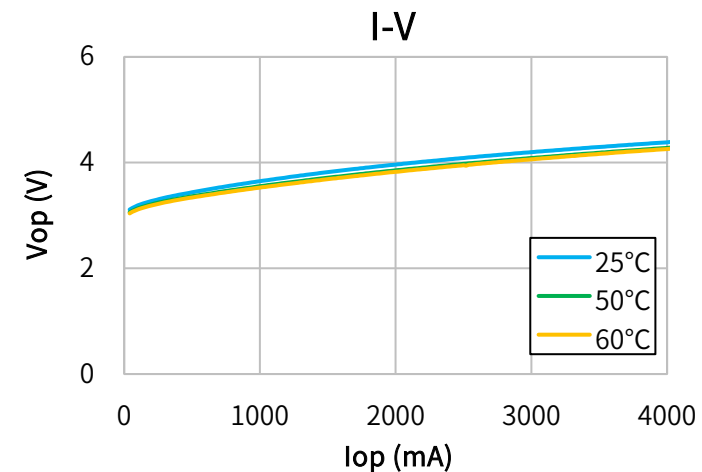
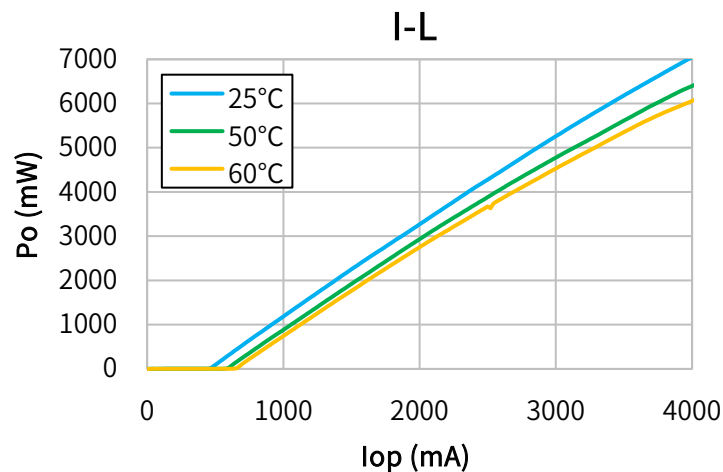

Far Field Pattern

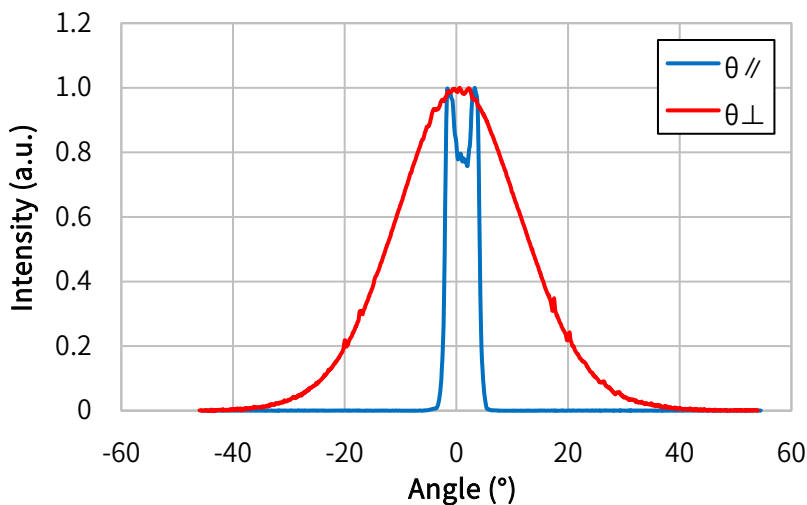

Near Field Pattern

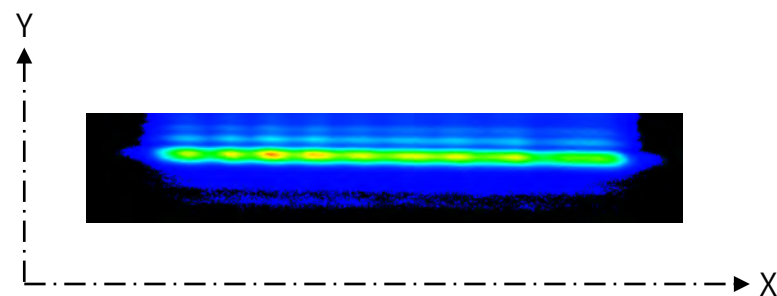

Emitter size

	FWHM (μm)	1/e (μm)	1/e ² (μm)
X	56.0	57.3	60.0
Y	1.42	1.70	2.59

X Profile

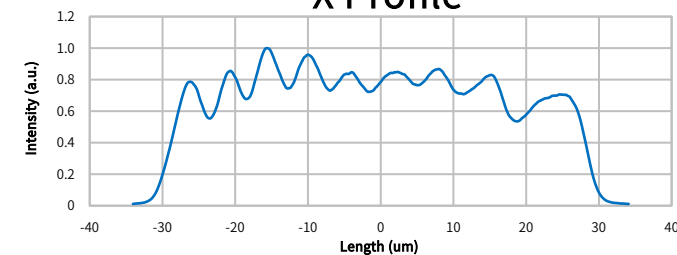

Y Profile

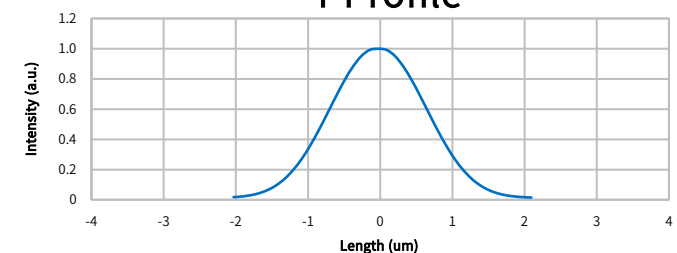



Characteristics

(Tc=25°C, CW)

Item	Conditions	Characteristic value (TYP.)
Wavelength (Peak)	Po=80mW	450nm
Output [Max]	—	80mW[85mW]
Threshold current	—	22mA
Operating current	Po=80mW	84mA
Operating voltage	Po=80mW	5.1V
Far Field (FWHM)	Po=80mW	$\theta_{//} 10^\circ, \theta_{\perp} 24^\circ$
Terminal connections	No.8	
Package type	φ5.6	

CW I-L, I-V Temperature

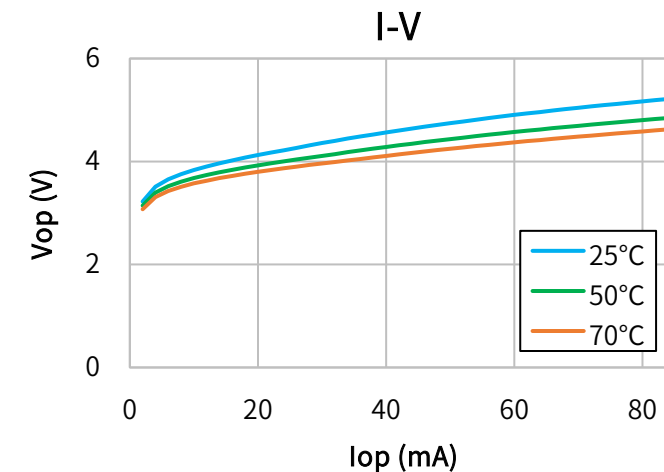
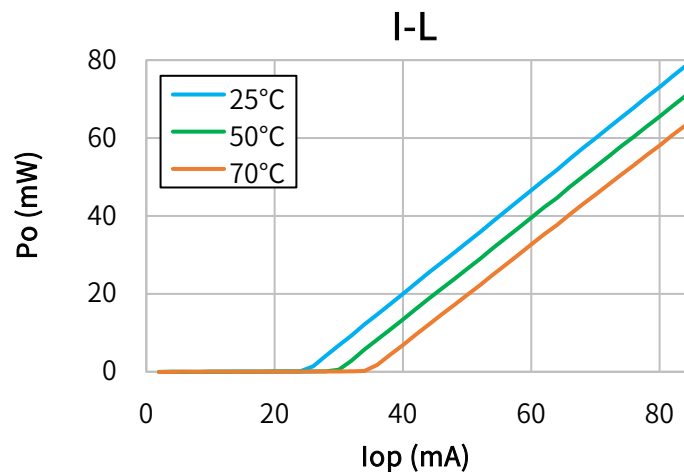

Far Field Pattern

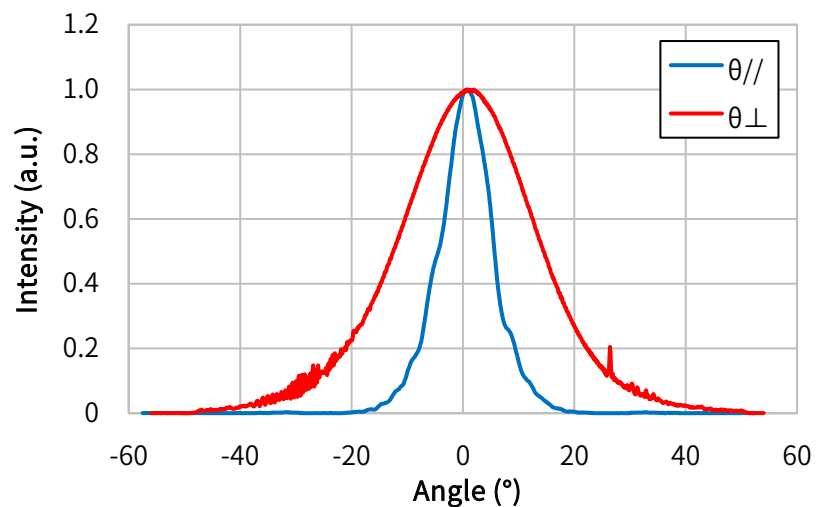

Near Field Pattern

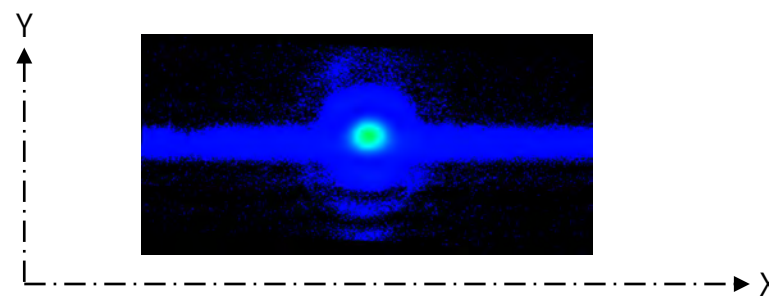

Emitter size

	FWHM (μm)	1/e (μm)	1/e ² (μm)
X	1.2	1.4	2.4
Y	0.8	1.0	1.4

X Profile

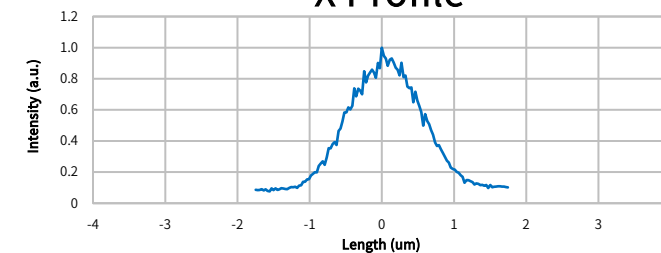

Y Profile

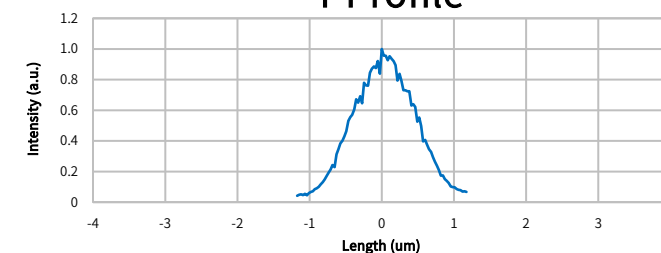



Characteristics

(Tc=25°C, CW)

Item	Conditions	Characteristic value (TYP.)
Wavelength (Peak)	Po=90mW	450nm
Output [Max]	—	90mW[95mW]
Threshold current	—	28mA
Operating current	Po=90mW	100mA
Operating voltage	Po=90mW	5.2V
Far Field (FWHM)	Po=90mW	θ// 9°, θ⊥ 24°
Terminal connections	No.8	
Package type	φ3.8	

CW I-L, I-V Temperature

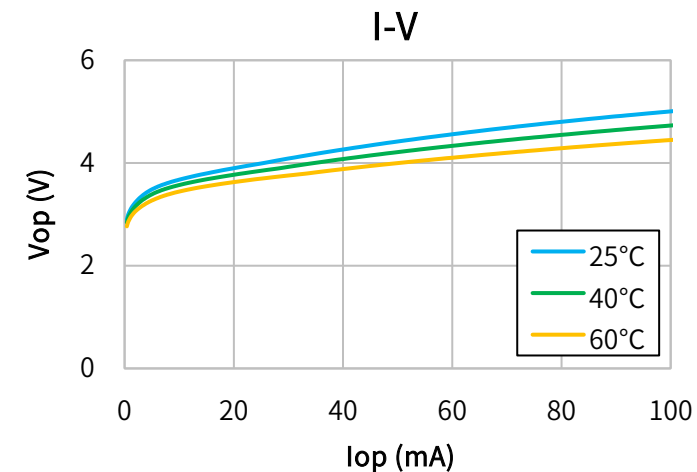
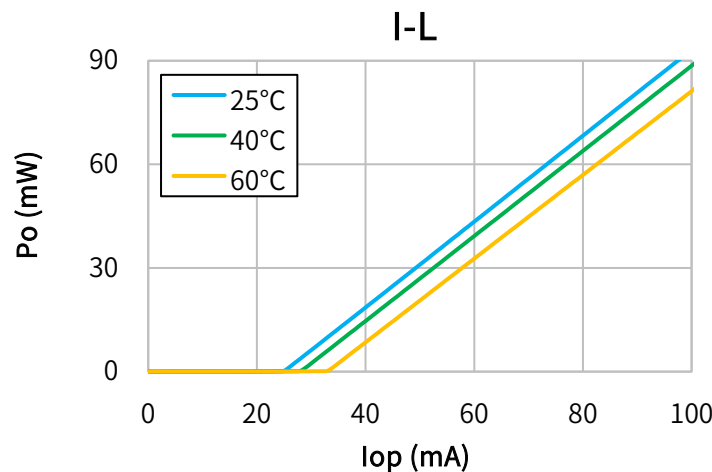

Far Field Pattern

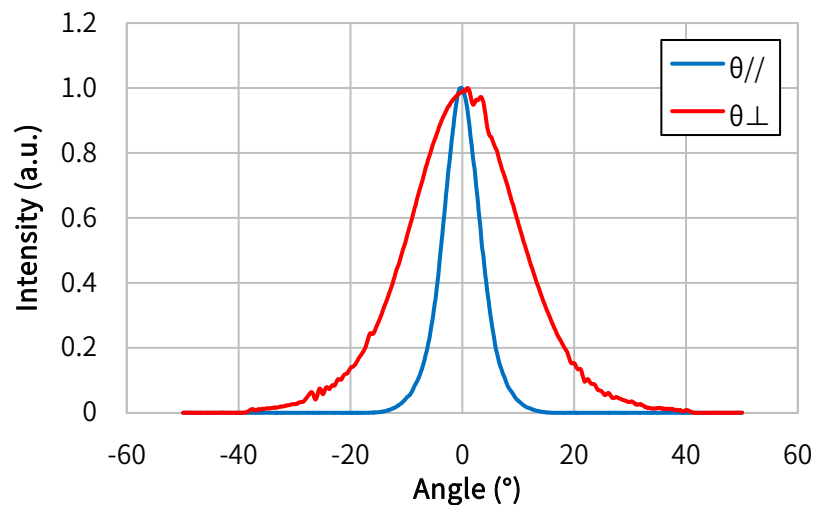

Near Field Pattern

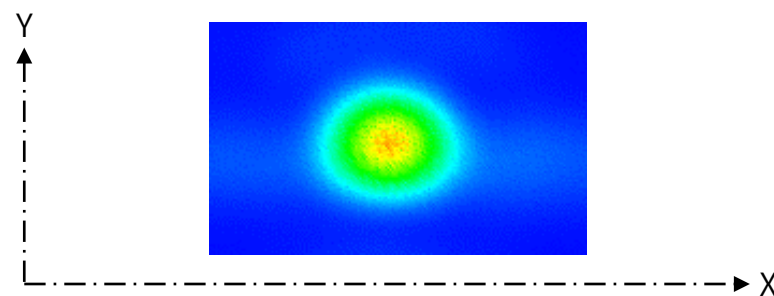

Emitter size

	FWHM (μm)	1/e (μm)	1/e ² (μm)
X	1.2	1.5	2.4
Y	1.0	1.2	1.7

X Profile

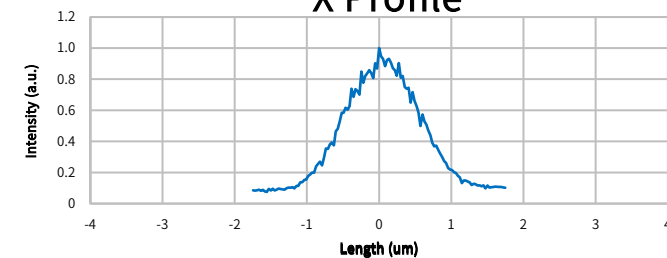

Y Profile

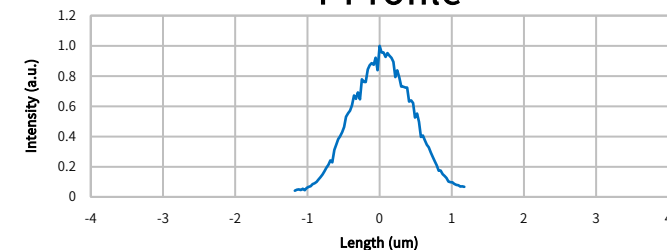



Characteristics

(Tc=25°C, CW)

Item	Conditions	Characteristic value (TYP.)
Wavelength (Peak)	Po=1800mW	450nm
Output [Max]	—	1800mW [2000mW]
Threshold current	—	110mA
Operating current	Po=1800mW	1100mA
Operating voltage	Po=1800mW	4.1V
Far Field (FWHM)	Po=1800mW	θ// 7°, θ⊥ 26°

Terminal connections	No.9
Package type	φ5.6

CW I-L, I-V Temperature

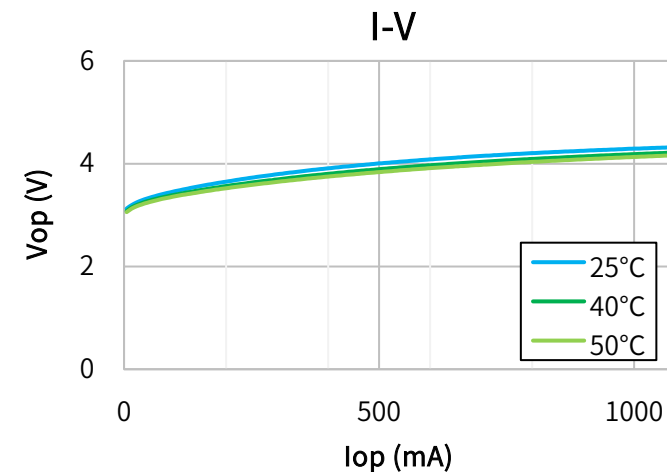
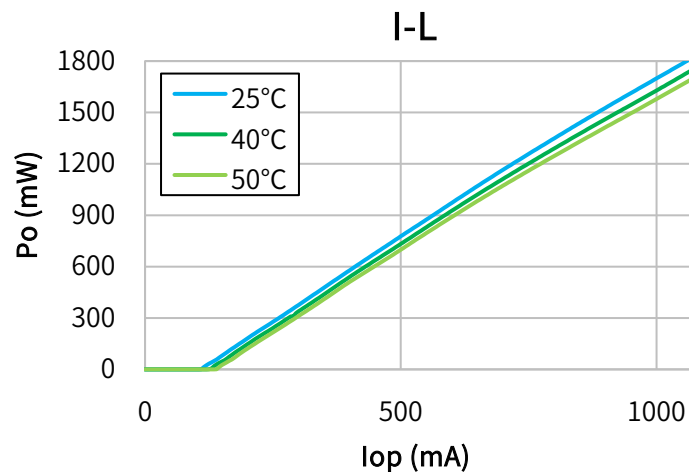

Far Field Pattern

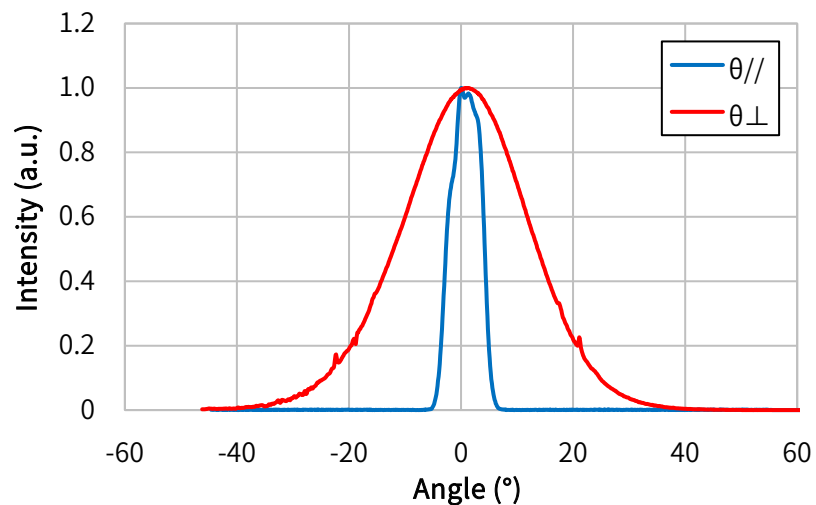

Near Field Pattern

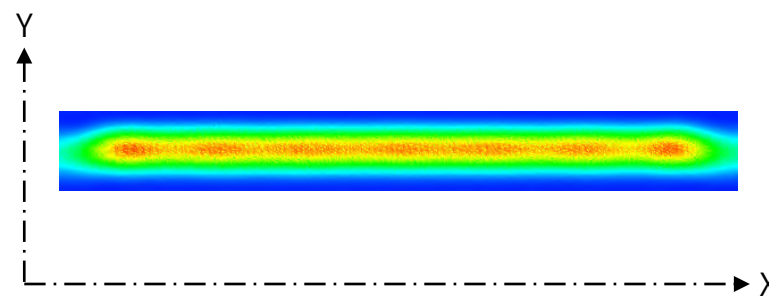

Emitter size

	FWHM (μm)	1/e (μm)	1/e ² (μm)
X	15.1	16.1	20.2
Y	0.8	1.0	1.3

X Profile

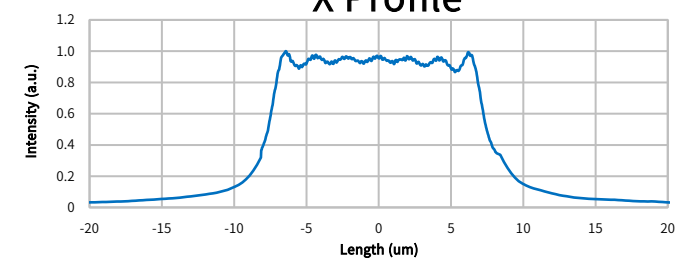

Y Profile

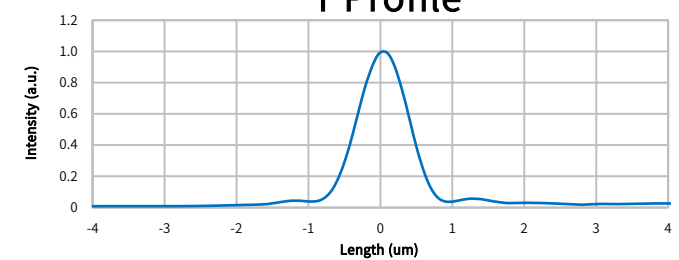



Characteristics

(Tc=25°C, CW)

Item	Conditions	Characteristic value (TYP.)
Wavelength (Peak)	Po=3500mW	450nm
Output	—	3500mW
Threshold current	—	260mA
Operating current	Po=3500mW	2100mA
Operating voltage	Po=3500mW	4.4V
Far Field (1/e ²)	Po=3500mW	θ// 9°, θ⊥ 47°
Terminal connections	No.13	
Package type	φ9.0	

CW I-L, I-V Temperature

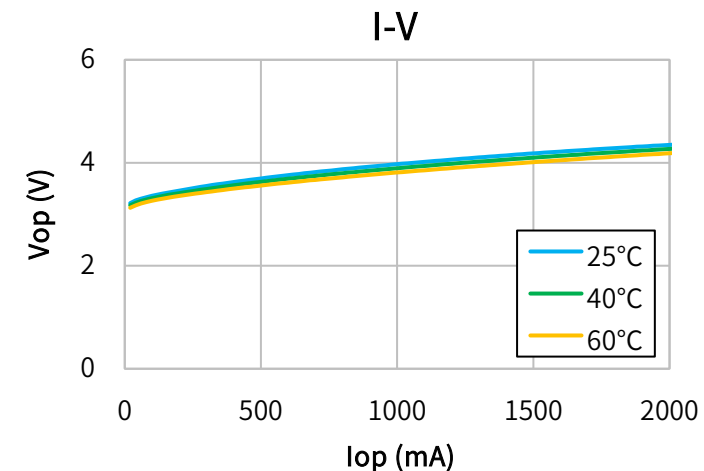
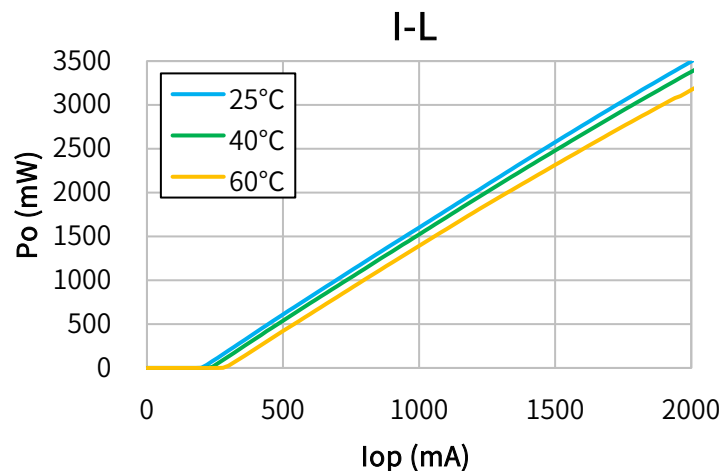

Far Field Pattern

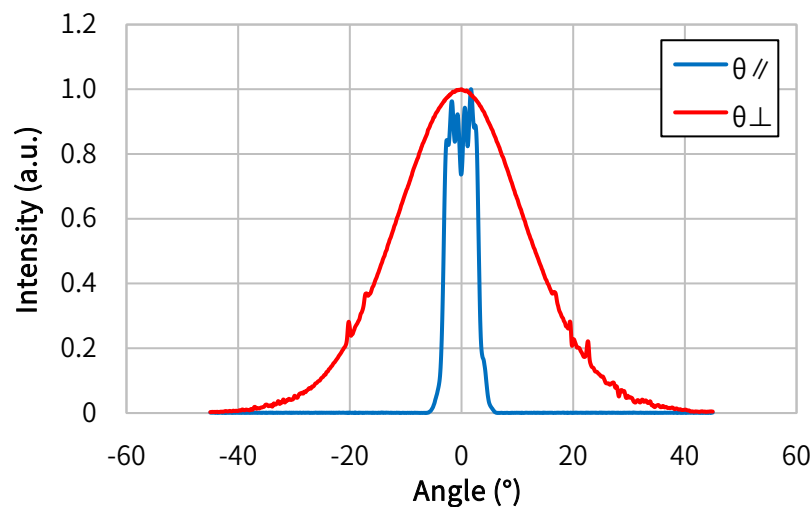

Near Field Pattern

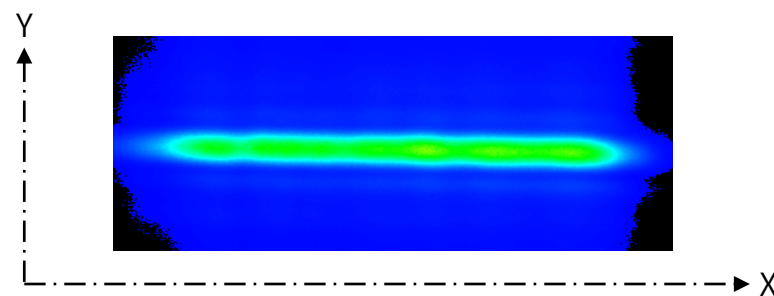

Emitter size

	FWHM (μm)	1/e (μm)	1/e ² (μm)
X	25.5	26.7	30.2
Y	1.4	1.6	2.3

X Profile

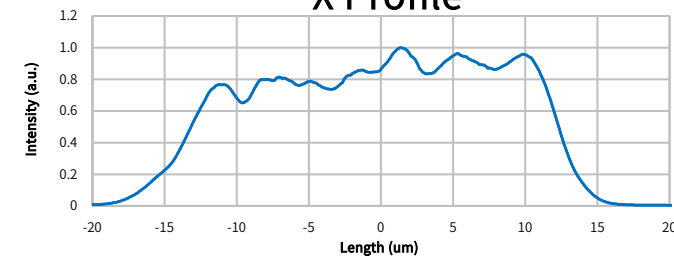

Y Profile

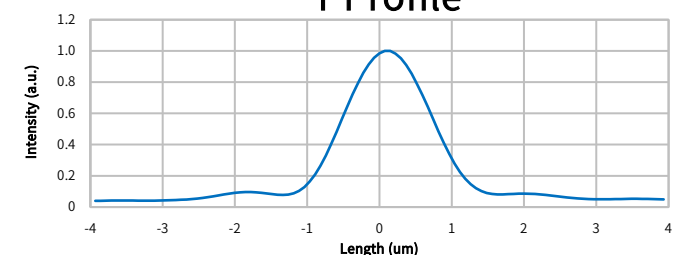



Characteristics

(Tc=25°C, CW)

Item	Conditions	Characteristic value (TYP.)
Wavelength (Peak)	Po=5000mW	450nm
Output	—	5000mW
Threshold current	—	300mA
Operating current	Po=5000mW	2950mA
Operating voltage	Po=5000mW	4.1V
Far Field (1/e ²)	Po=5000mW	θ// 9°, θ⊥ 46°
Terminal connections	No.13	
Package type	φ9.0	

CW I-L, I-V Temperature

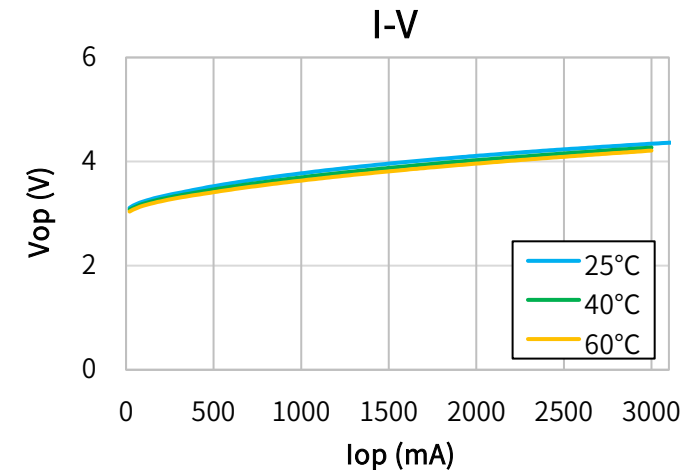
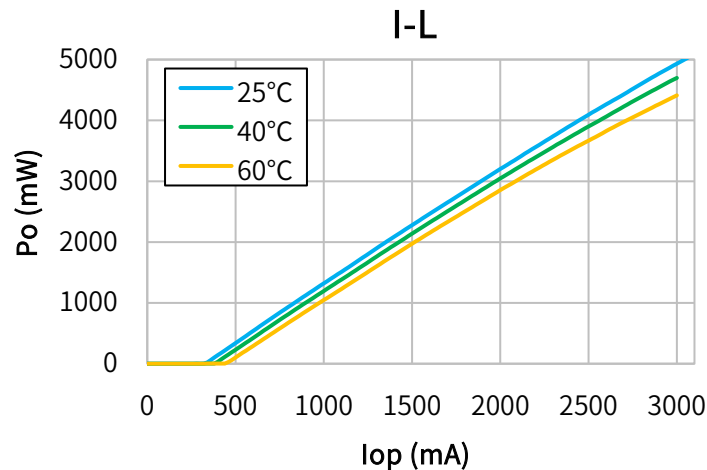

Far Field Pattern

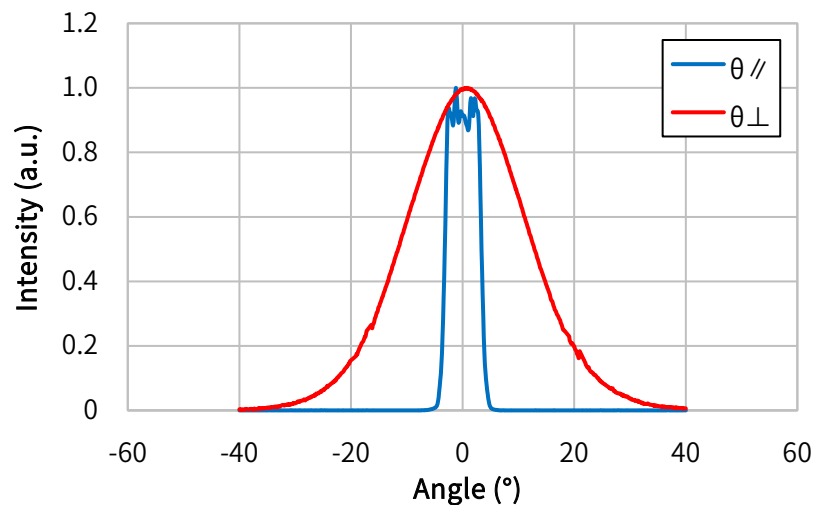

Near Field Pattern

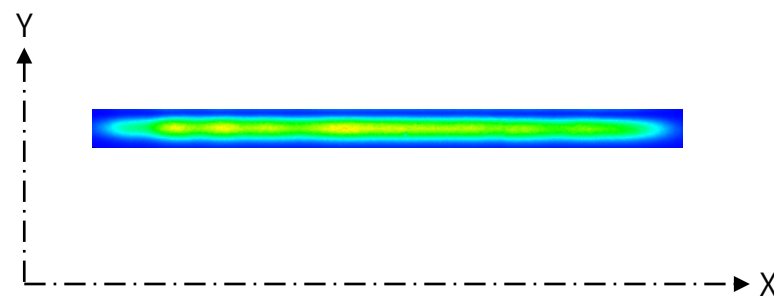

Emitter size

	FWHM (μm)	1/e (μm)	1/e ² (μm)
X	39.3	42.0	45.6
Y	1.6	3.0	3.7

X Profile

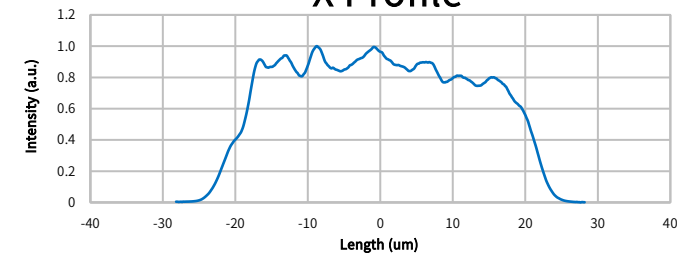

Y Profile

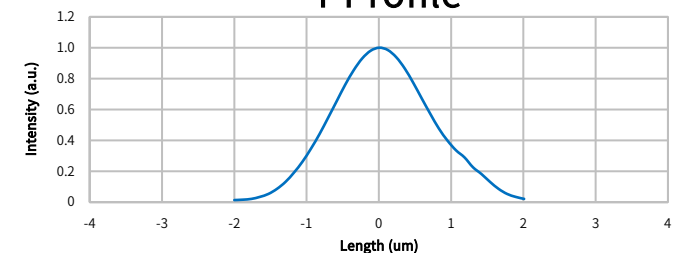



Characteristics

(Tc=25°C, CW)

Item	Conditions	Characteristic value (TYP.)
Wavelength (Peak)	Po=50mW	487nm
Output [Max]	—	50mW[55mW]
Threshold current	—	40mA
Operating current	Po=50mW	105mA
Operating voltage	Po=50mW	6.0V
Far Field (FWHM)	Po=50mW	θ// 8°, θ⊥ 23°
Terminal connections	No.8	
Package type	φ5.6	

CW I-L, I-V Temperature

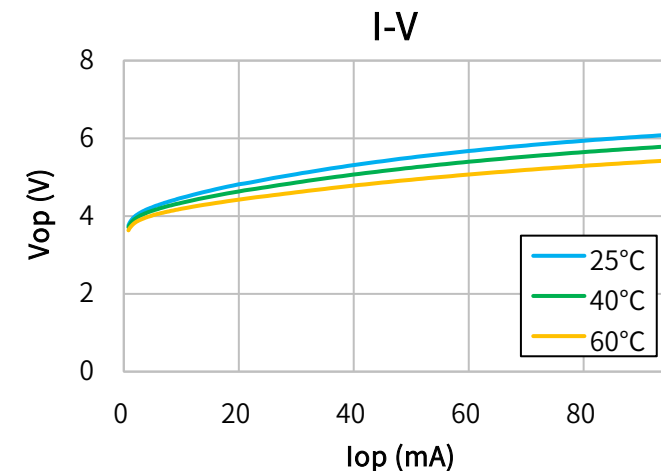
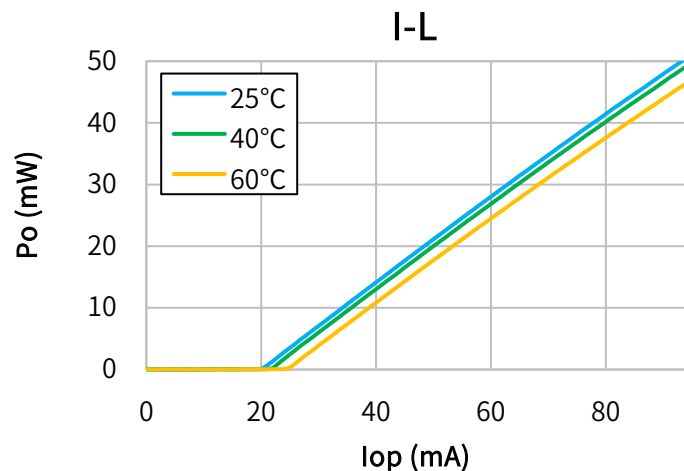

Far Field Pattern

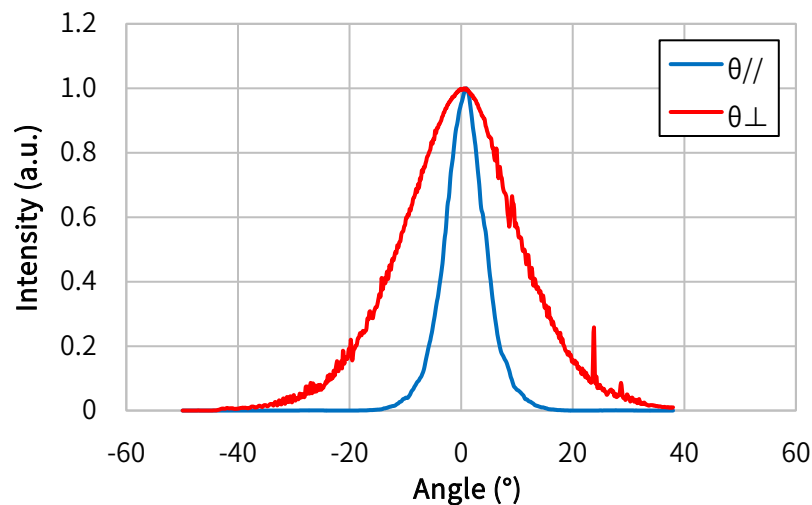

Near Field Pattern

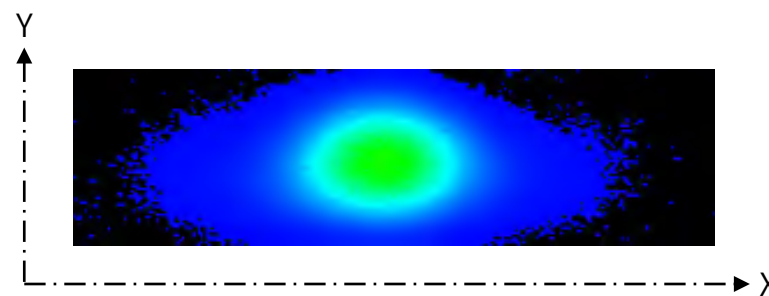

Emitter size

	FWHM (μm)	1/e (μm)	1/e ² (μm)
X	1.3	1.6	2.4
Y	0.8	1.0	1.4

X Profile

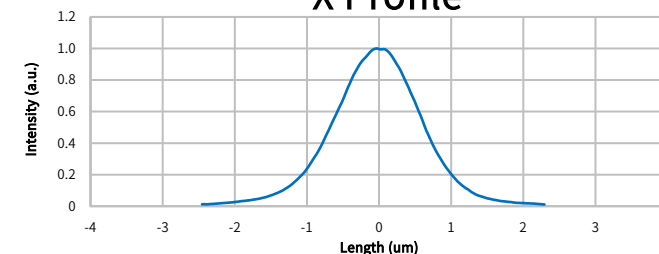

Y Profile

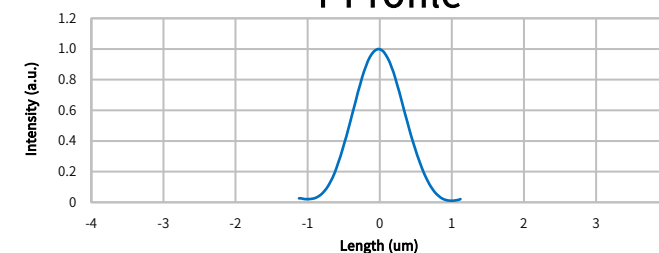



Characteristics

(T_c=25°C, CW)

Item	Conditions	Characteristic value (TYP.)
Wavelength (Peak)	Po=80mW	498nm
Output [Max]	—	80mW[85mW]
Threshold current	—	30mA
Operating current	Po=80mW	120mA
Operating voltage	Po=80mW	6.0V
Far Field (FWHM)	Po=80mW	θ// 7°, θ⊥ 22°
Terminal connections	No.4	
Package type	φ3.8	

CW I-L, I-V Temperature

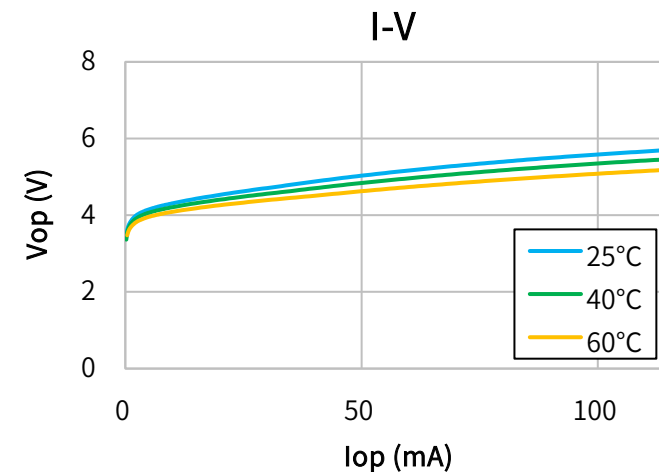
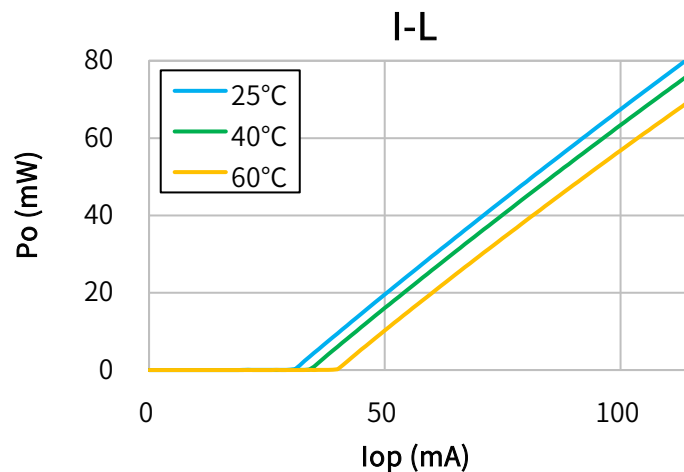

Far Field Pattern

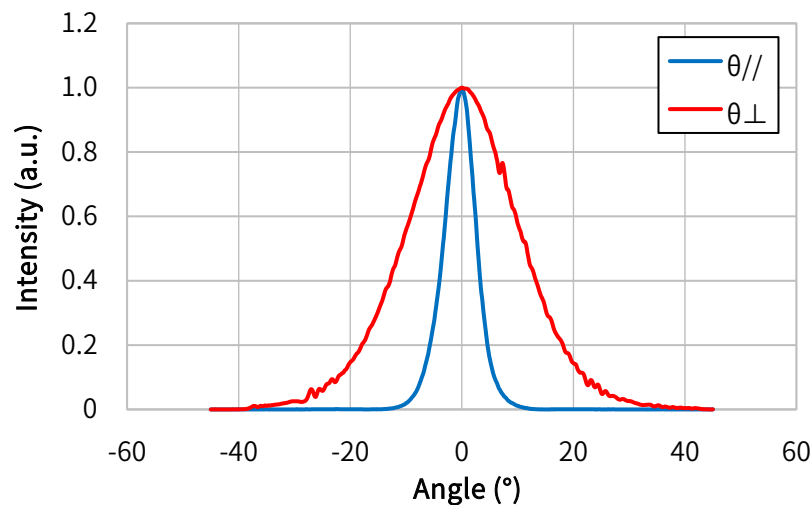

Near Field Pattern

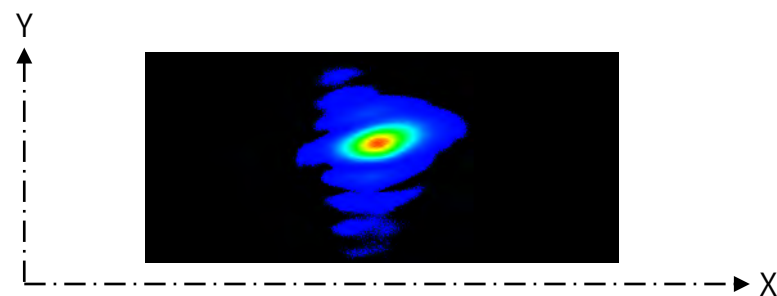

Emitter size

	FWHM (μm)	1/e (μm)	1/e ² (μm)
X	1.7	2.1	3.2
Y	0.8	1.0	1.3

X Profile

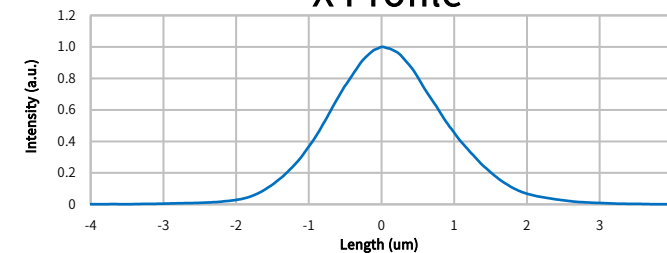

Y Profile

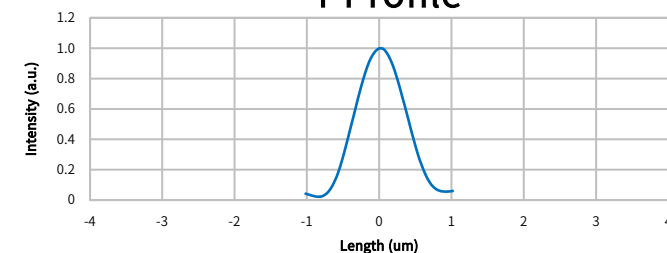



Characteristics

(Tc=25°C, CW)

Item	Conditions	Characteristic value (TYP.)
Wavelength (Peak)	Po=30mW	505nm
Output [Max]	—	30mW[35mW]
Threshold current	—	30mA
Operating current	Po=30mW	75mA
Operating voltage	Po=30mW	6.0V
Far Field (FWHM)	Po=30mW	θ// 8°, θ⊥ 23°
Terminal connections	No.4	
Package type	φ5.6	

CW I-L, I-V Temperature

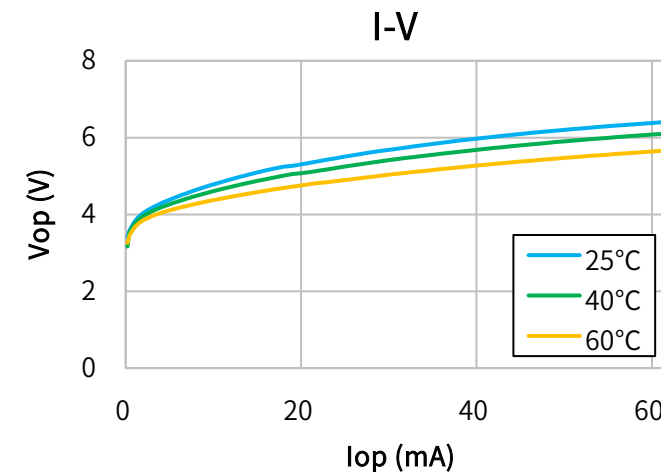
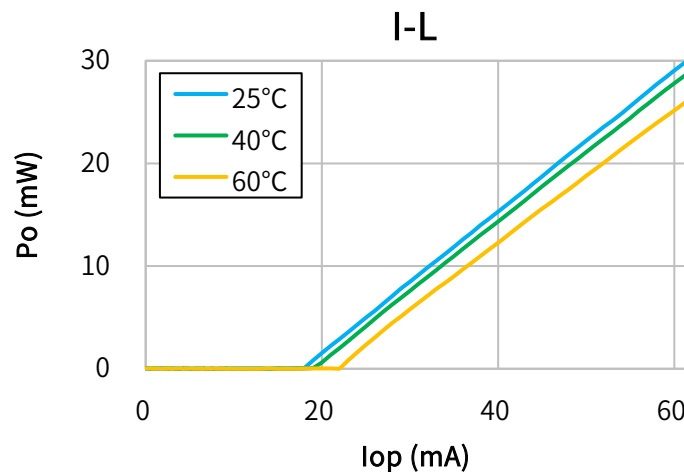

Far Field Pattern

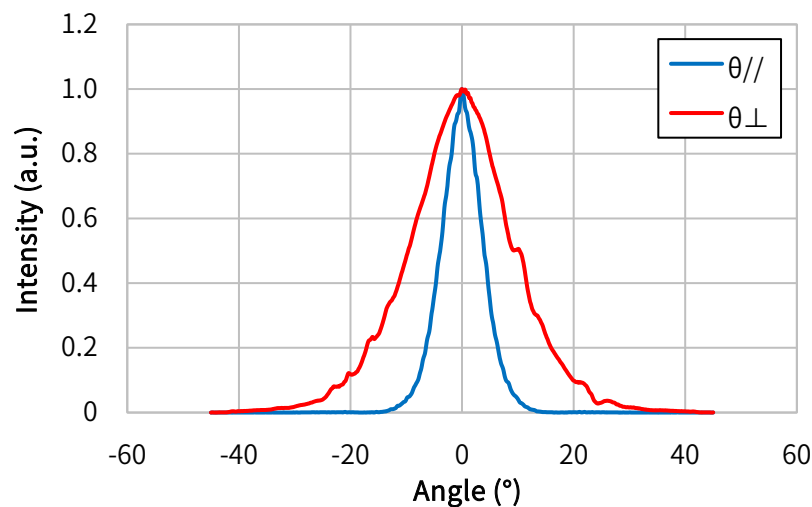

Near Field Pattern

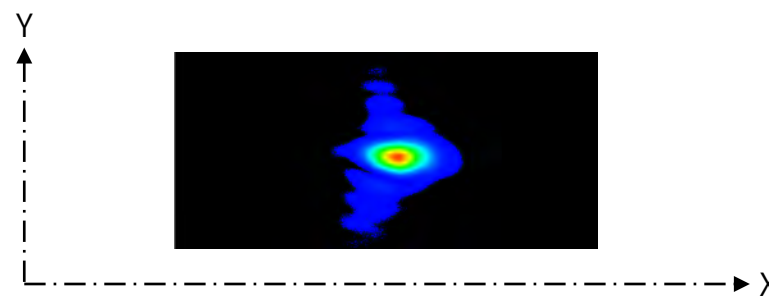

Emitter size

	FWHM (μm)	1/e (μm)	1/e ² (μm)
X	1.6	1.9	2.8
Y	0.8	1.0	1.3

X Profile

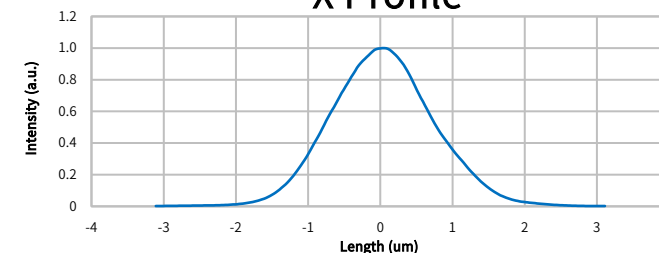

Y Profile

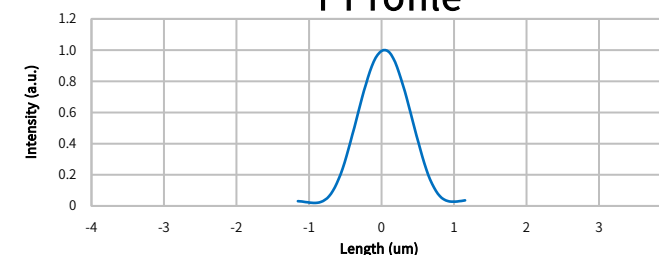



Characteristics

(Tc=25°C, CW)

Item	Conditions	Characteristic value (TYP.)
Wavelength (Peak)	Po=30mW	518nm
Output [Max]	—	30mW[35mW]
Threshold current	—	25mA
Operating current	Po=30mW	75mA
Operating voltage	Po=30mW	6.2V
Far Field (FWHM)	Po=30mW	θ// 7.5°, θ⊥ 22°
Terminal connections	No.8	
Package type	φ5.6	

CW I-L, I-V Temperature

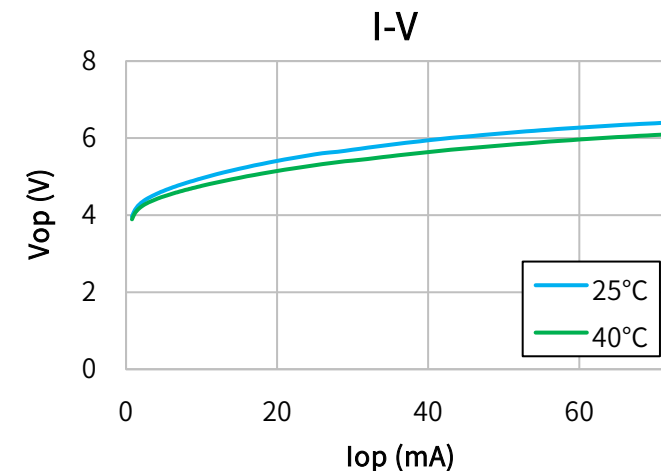
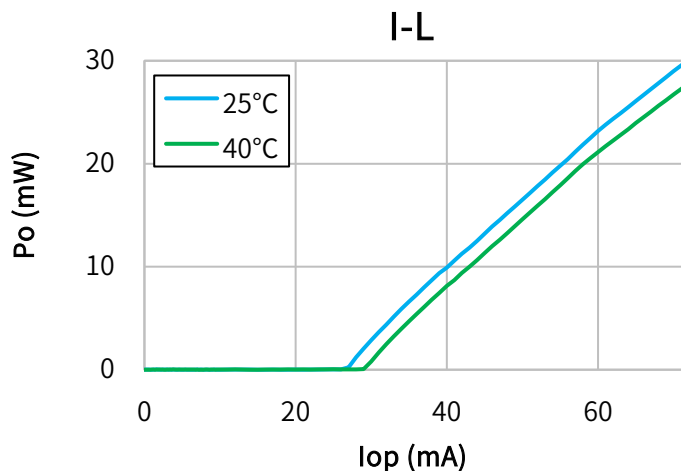

Far Field Pattern

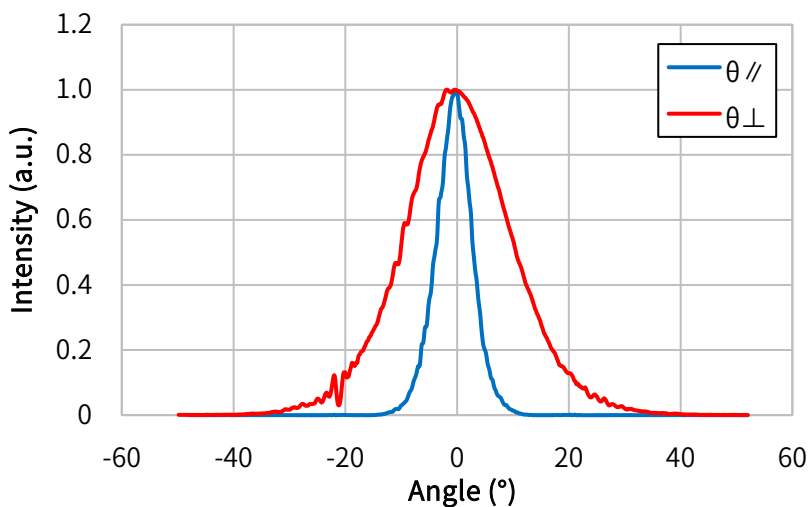

Near Field Pattern

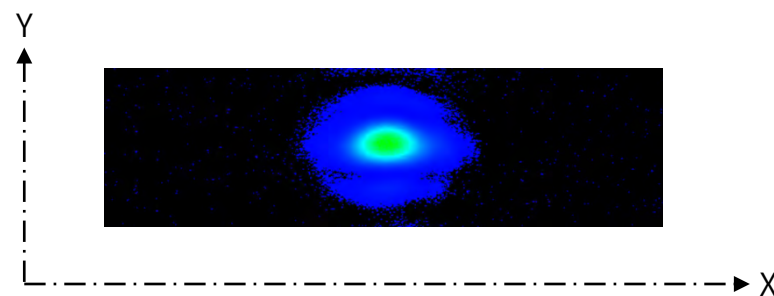

Emitter size

	FWHM (μm)	1/e (μm)	1/e ² (μm)
X	1.3	1.5	2.4
Y	0.7	0.9	1.2

X Profile

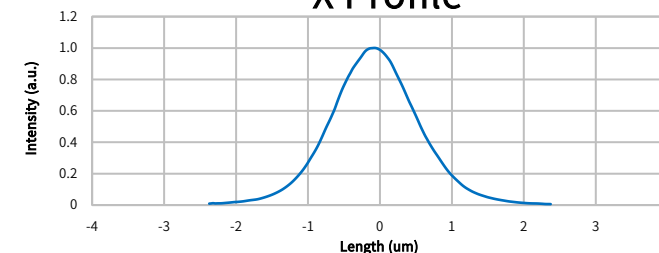

Y Profile

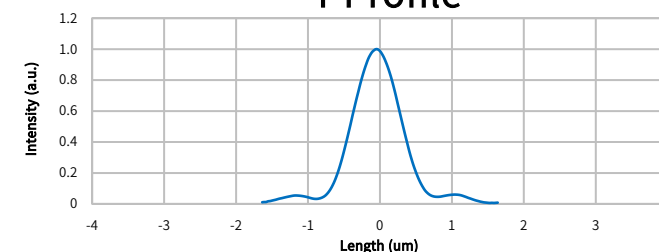



Characteristics

(Tc=25°C, CW)

Item	Conditions	Characteristic value (TYP.)
Wavelength (Peak)	Po=30mW	518nm
Output [Max]	—	30mW[35mW]
Threshold current	—	25mA
Operating current	Po=30mW	75mA
Operating voltage	Po=30mW	6.2V
Far Field (FWHM)	Po=30mW	$\theta_{//}$ 7.5°, θ_{\perp} 22°
Terminal connections	No.6	
Package type	t1.8	

CW I-L, I-V Temperature

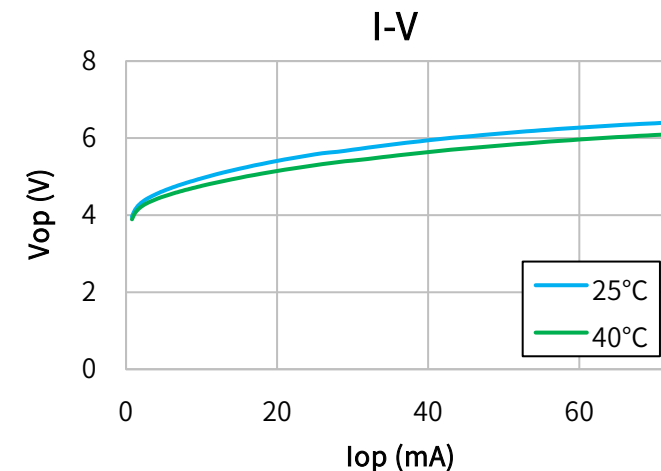
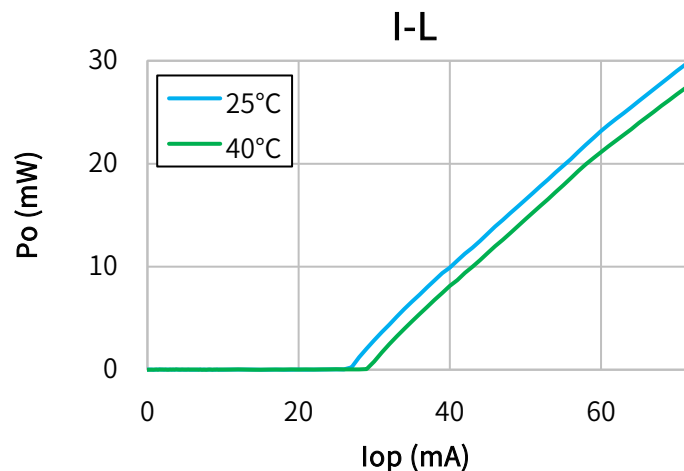

Far Field Pattern

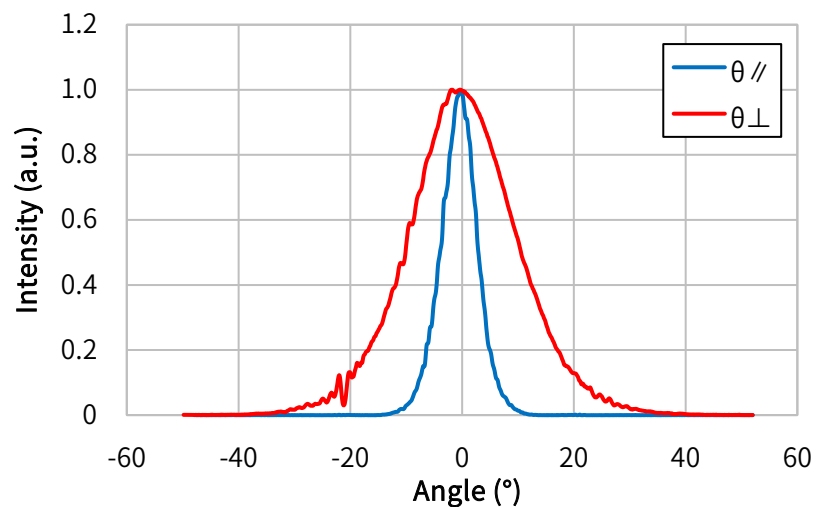

Near Field Pattern

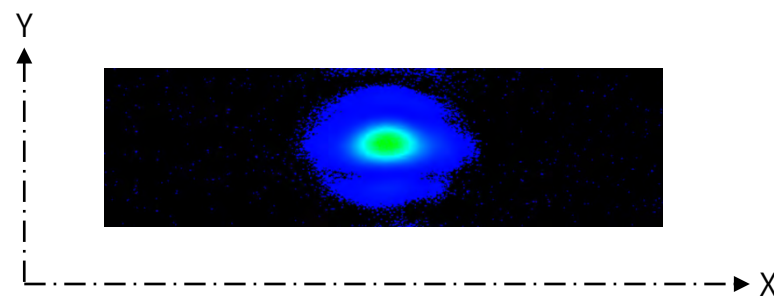

Emitter size

	FWHM (μm)	1/e (μm)	1/e ² (μm)
X	1.3	1.5	2.4
Y	0.7	0.9	1.2

X Profile

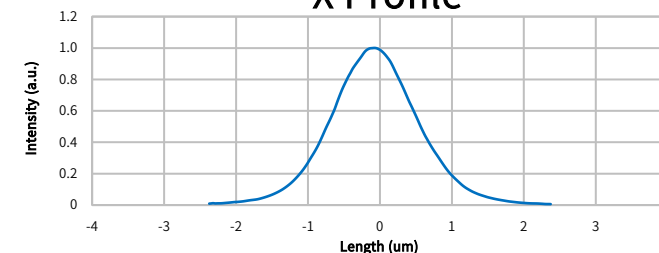

Y Profile

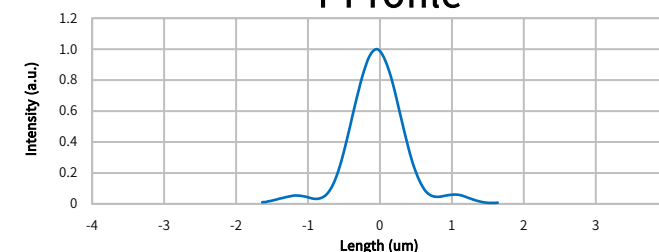



Characteristics

(T_c=25°C, CW)

Item	Conditions	Characteristic value (TYP.)
Wavelength (Peak)	Po=10mW	520nm
Output [Max]	—	10mW[15mW]
Threshold current	—	25mA
Operating current	Po=10mW	35mA
Operating voltage	Po=10mW	5.8V
Far Field (FWHM)	Po=10mW	θ// 7°, θ⊥ 22°
Terminal connections	No.4	
Package type	φ5.6	

CW I-L, I-V Temperature

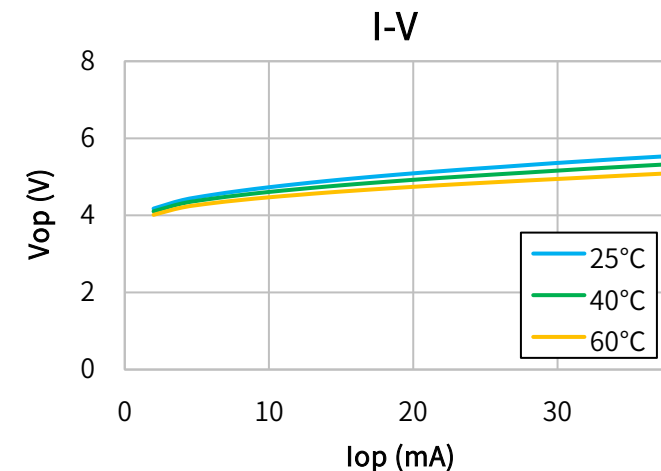
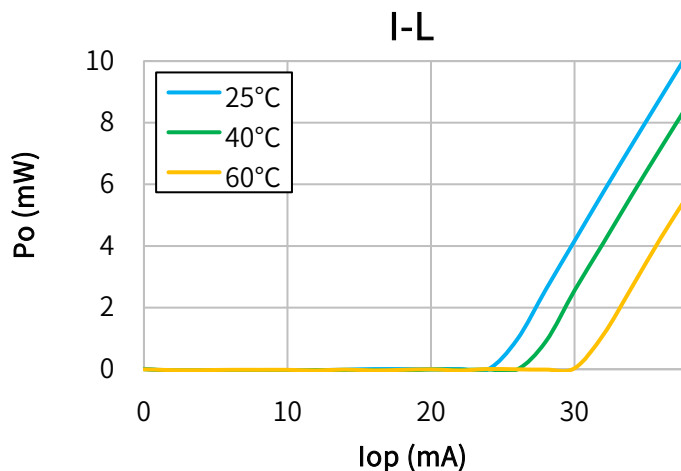

Far Field Pattern

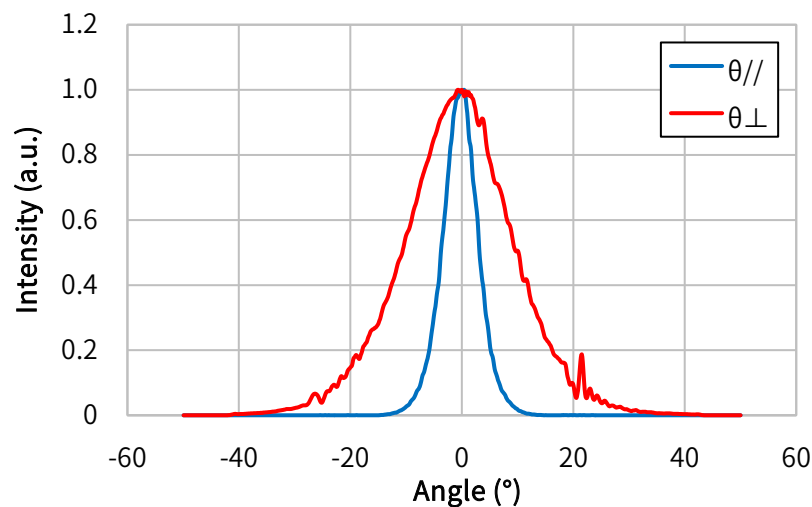

Near Field Pattern

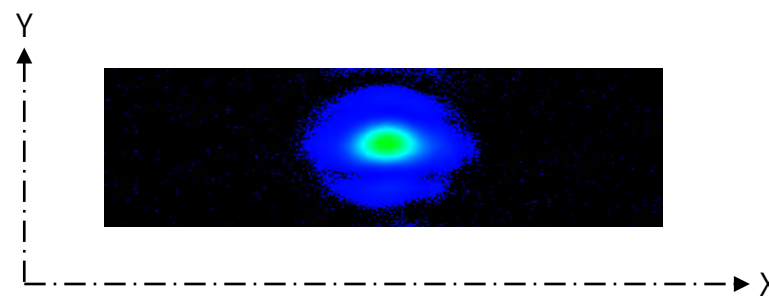

Emitter size

	FWHM (μm)	1/e (μm)	1/e ² (μm)
X	1.3	1.5	2.4
Y	0.7	0.9	1.2

X Profile

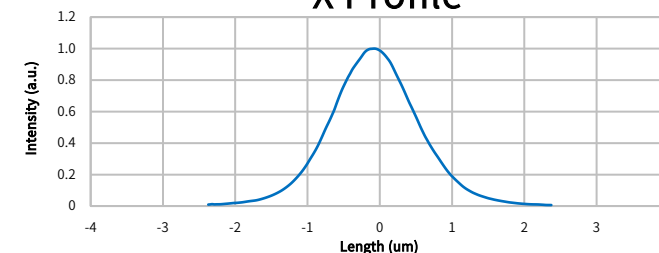

Y Profile

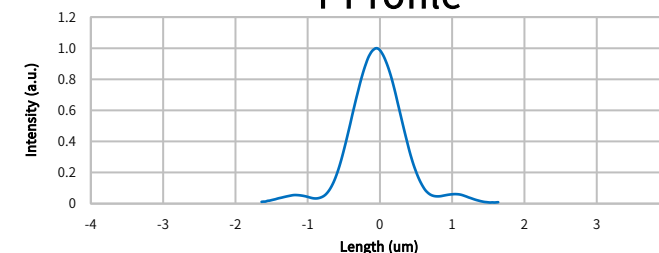



Characteristics

(Tc=25°C, CW)

Item	Conditions	Characteristic value (TYP.)
Wavelength (Peak)	Po=10mW	520nm
Output [Max]	—	10mW[15mW]
Threshold current	—	25mA
Operating current	Po=10mW	35mA
Operating voltage	Po=10mW	5.8V
Far Field (FWHM)	Po=10mW	$\theta_{//} 7^\circ, \theta_{\perp} 22^\circ$
Terminal connections	No.4	
Package type	φ3.8	

CW I-L, I-V Temperature

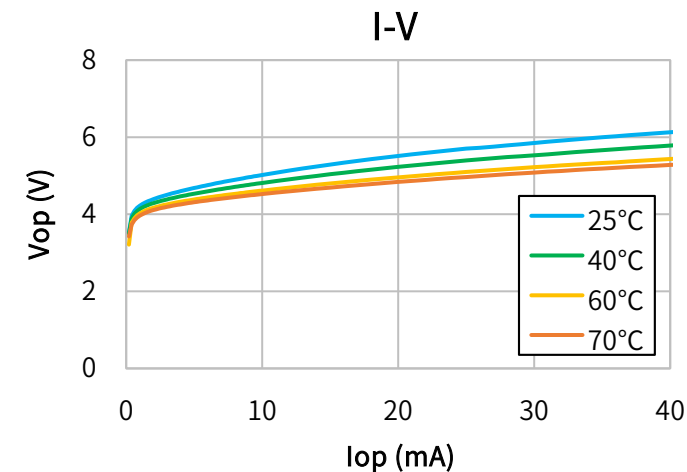
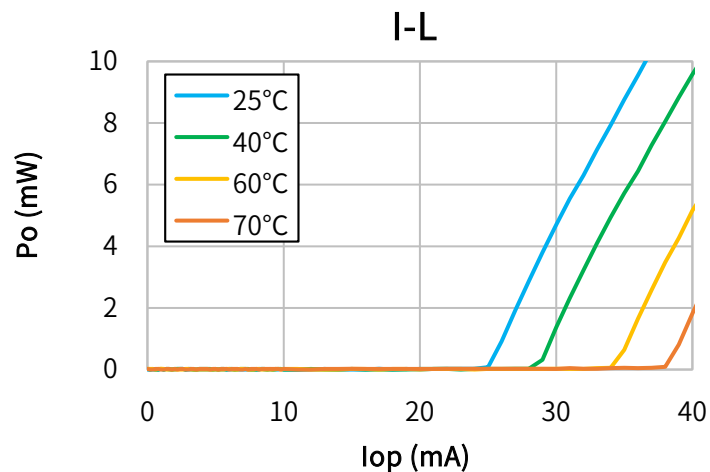

Far Field Pattern

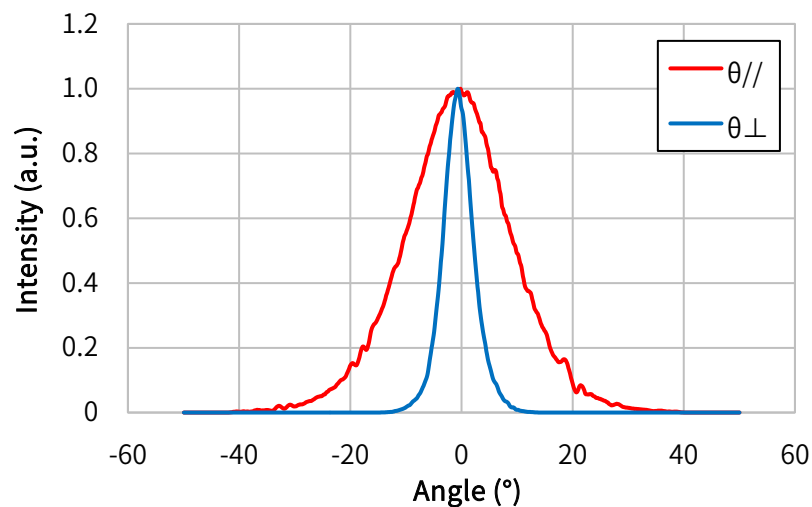

Near Field Pattern

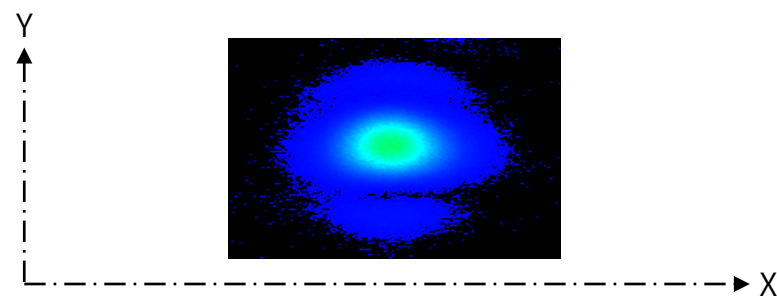

Emitter size

	FWHM (μm)	1/e (μm)	1/e ² (μm)
X	1.3	1.6	2.4
Y	0.7	0.9	1.2

X Profile

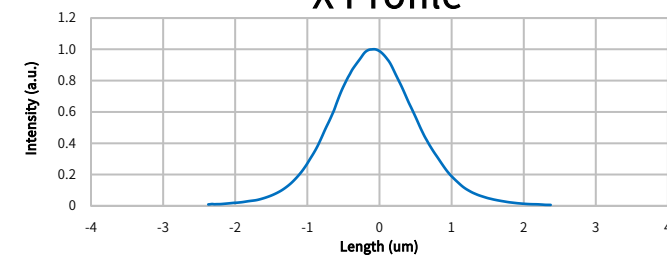

Y Profile

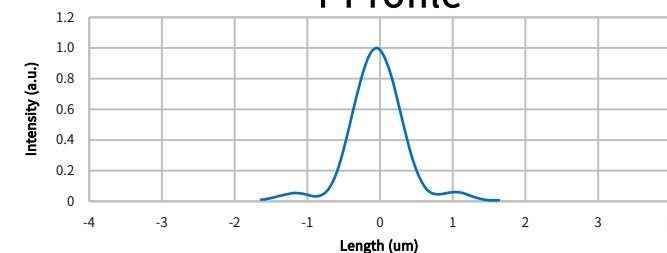



Characteristics

(Tc=25°C, CW)

Item	Conditions	Characteristic value (TYP.)
Wavelength (Peak)	Po=30mW	520nm
Output [Max]	—	30mW[35mW]
Threshold current	—	25mA
Operating current	Po=30mW	70mA
Operating voltage	Po=30mW	6.5V
Far Field (FWHM)	Po=30mW	θ// 7°, θ⊥ 22°
Terminal connections	No.4	
Package type	φ5.6	

CW I-L, I-V Temperature

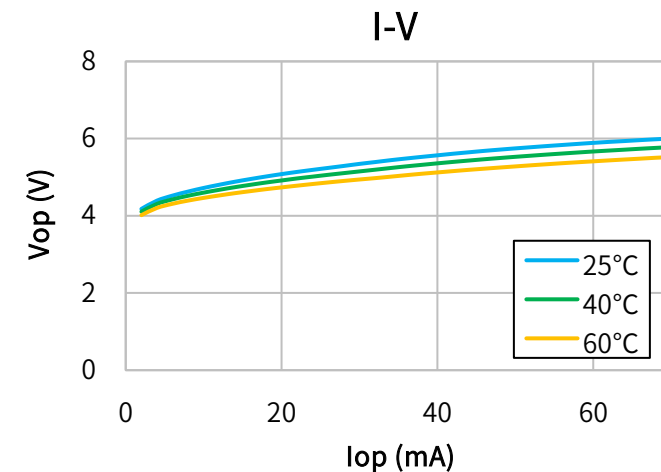
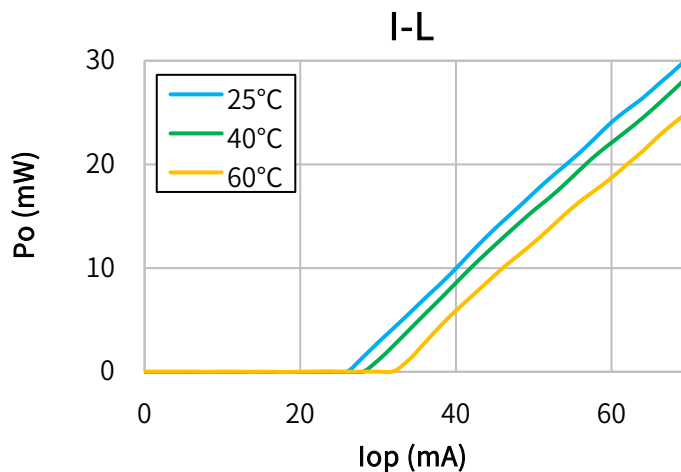

Far Field Pattern

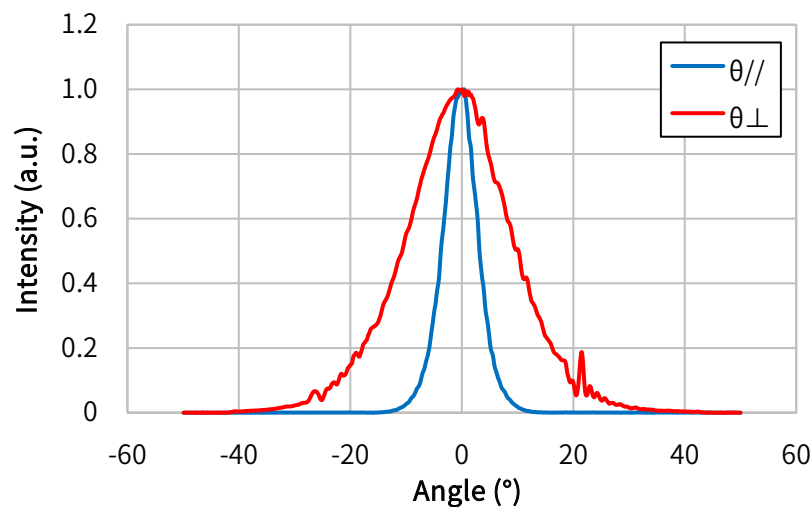

Near Field Pattern

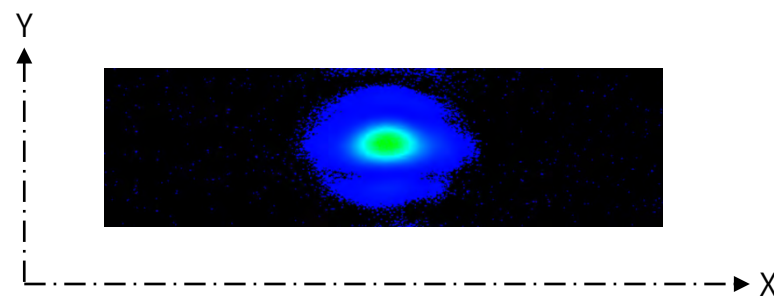

Emitter size

	FWHM (μm)	1/e (μm)	1/e ² (μm)
X	1.3	1.5	2.4
Y	0.7	0.9	1.2

X Profile

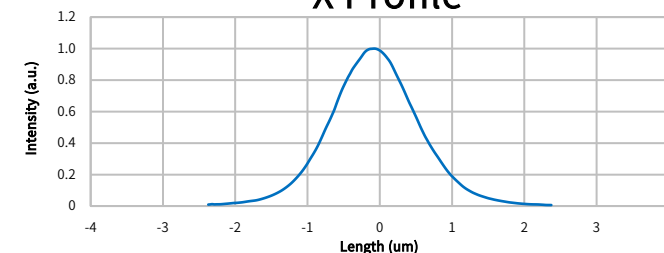

Y Profile

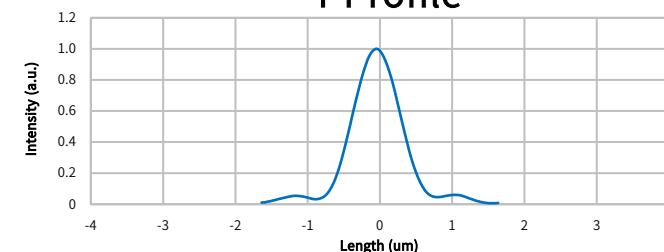



Characteristics

(Tc=25°C, CW)

Item	Conditions	Characteristic value (TYP.)
Wavelength (Peak)	Po=50mW	520nm
Output [Max]	—	50mW[55mW]
Threshold current	—	40mA
Operating current	Po=50mW	100mA
Operating voltage	Po=50mW	5.9V
Far Field (FWHM)	Po=50mW	θ// 7°, θ⊥ 22°
Terminal connections	No.4	
Package type	φ5.6	

CW I-L, I-V Temperature

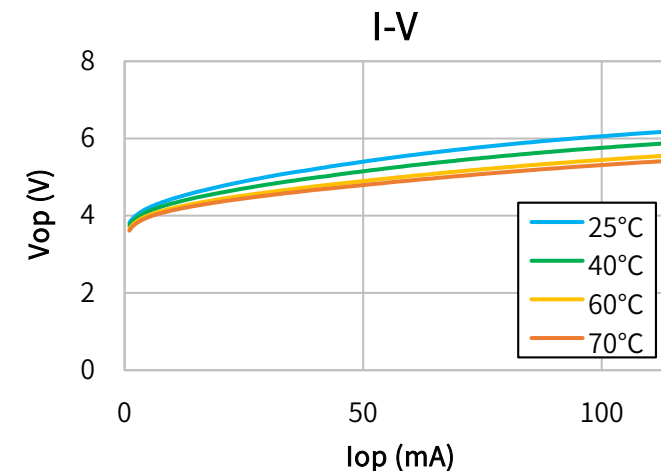
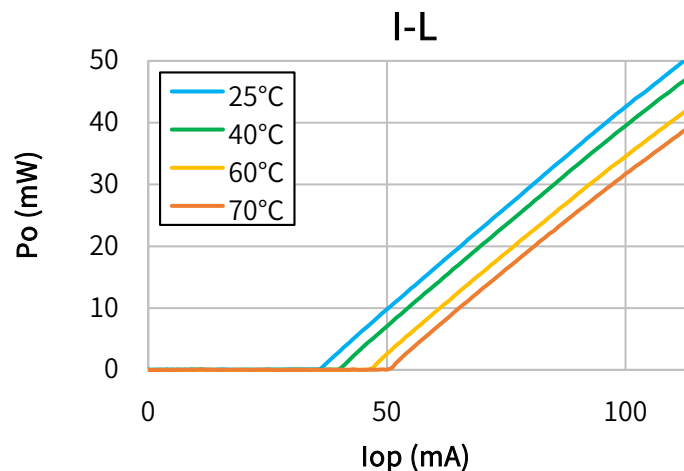

Far Field Pattern

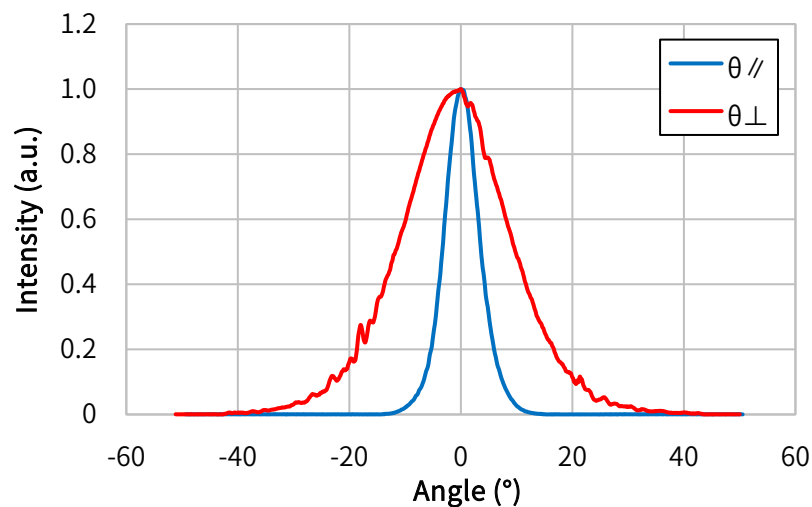

Near Field Pattern

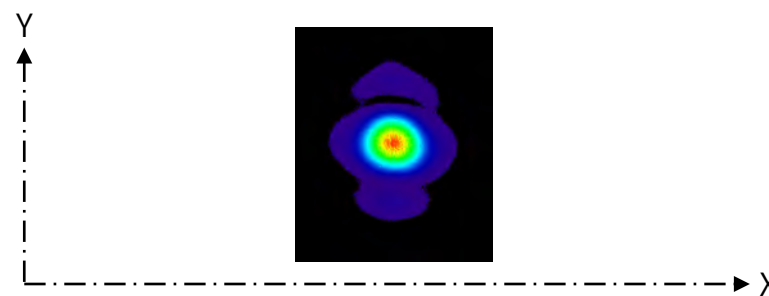

Emitter size

	FWHM (μm)	1/e (μm)	1/e ² (μm)
X	1.8	2.1	3.0
Y	0.8	0.9	1.2

X Profile

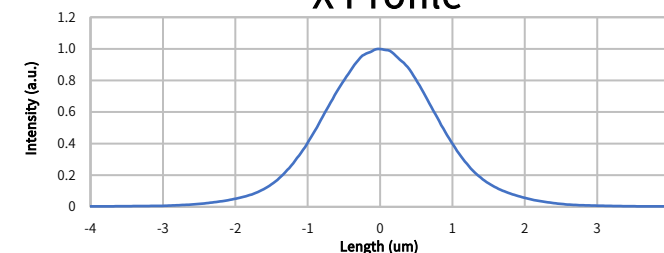

Y Profile

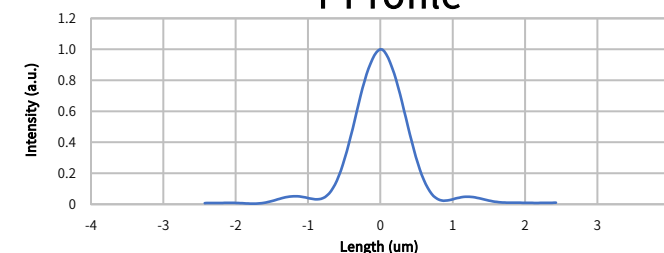



Characteristics

(Tc=25°C, CW)

Item	Conditions	Characteristic value (TYP.)
Wavelength (Peak)	Po=80mW	520nm
Output [Max]	—	80mW[85mW]
Threshold current	—	50mA
Operating current	Po=80mW	150mA
Operating voltage	Po=80mW	6.5V
Far Field (FWHM)	Po=80mW	θ// 7°, θ⊥ 23°
Terminal connections	No.4	
Package type	φ5.6	

CW I-L, I-V Temperature

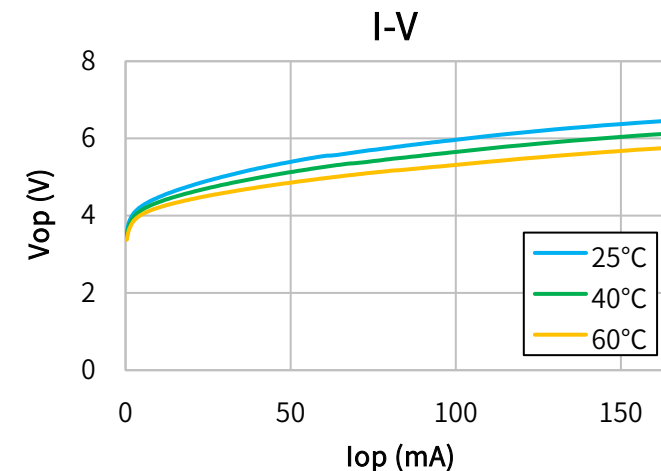
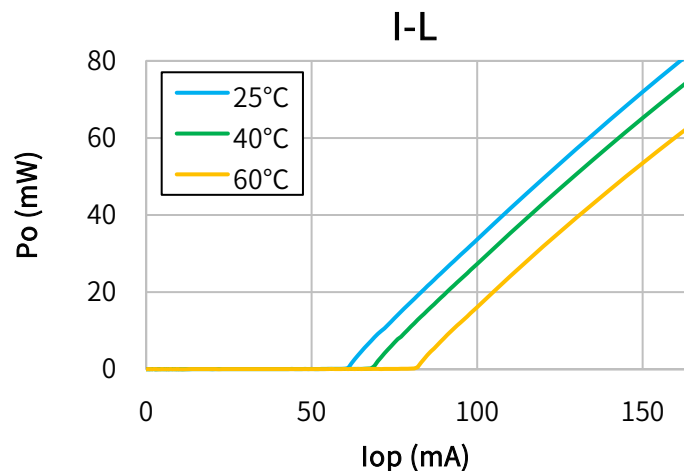

Far Field Pattern

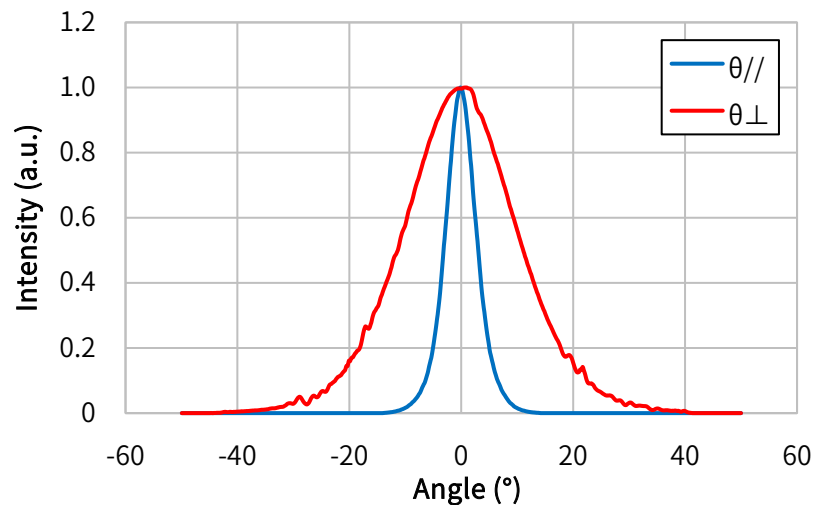

Near Field Pattern

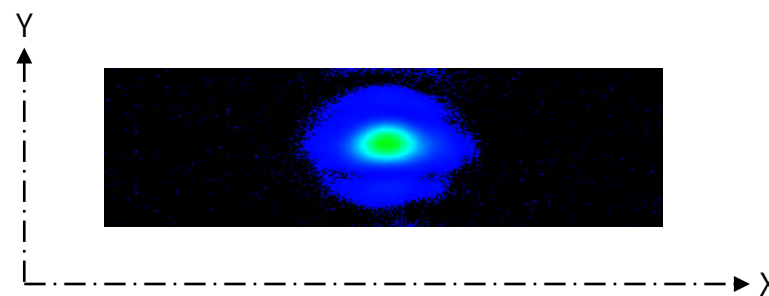

Emitter size

	FWHM (μm)	1/e (μm)	1/e ² (μm)
X	1.3	1.5	2.4
Y	0.7	0.9	1.2

X Profile

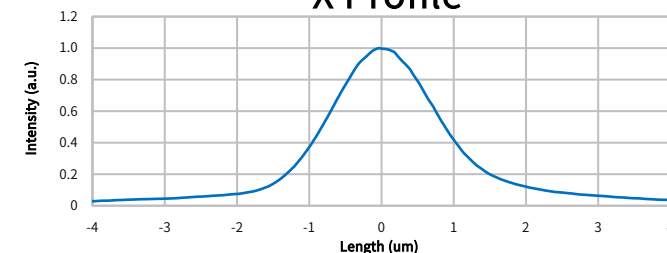

Y Profile

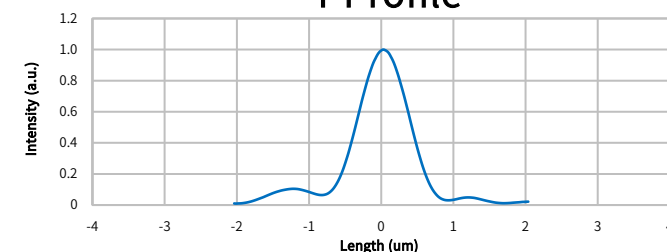



Characteristics

(Tc=25°C, CW)

Item	Conditions	Characteristic value (TYP.)
Wavelength (Peak)	Po=80mW	520nm
Output [Max]	—	80mW[85mW]
Threshold current	—	65mA
Operating current	Po=80mW	180mA
Operating voltage	Po=80mW	6.5V
Far Field (FWHM)	Po=80mW	θ// 7°, θ⊥ 23°
Terminal connections	No.4	
Package type	φ3.8	

CW I-L, I-V Temperature

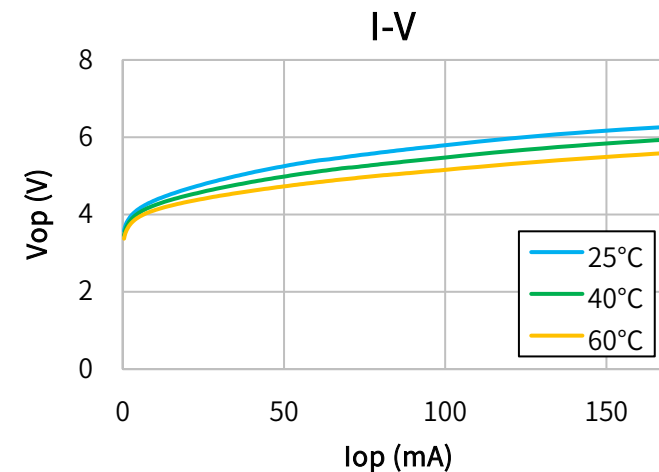
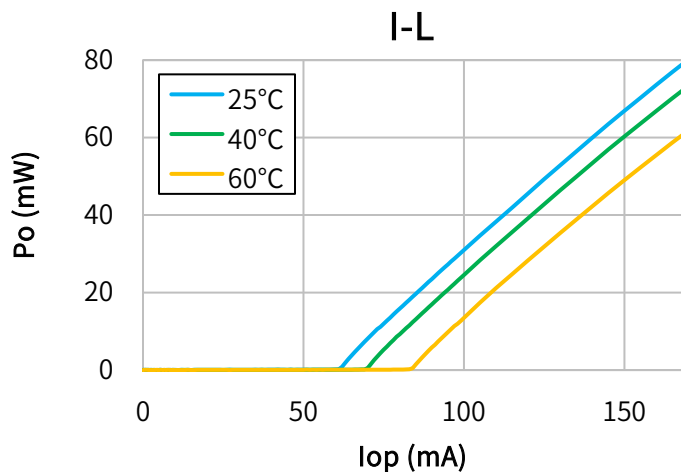

Far Field Pattern

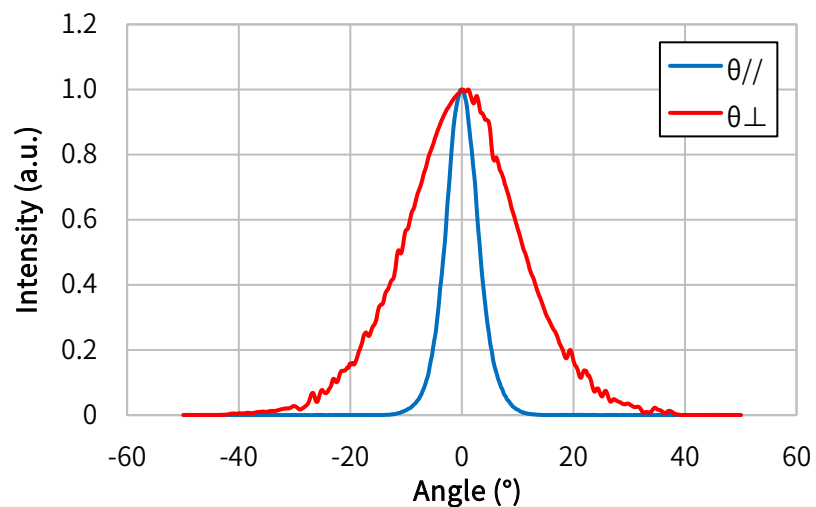

Near Field Pattern

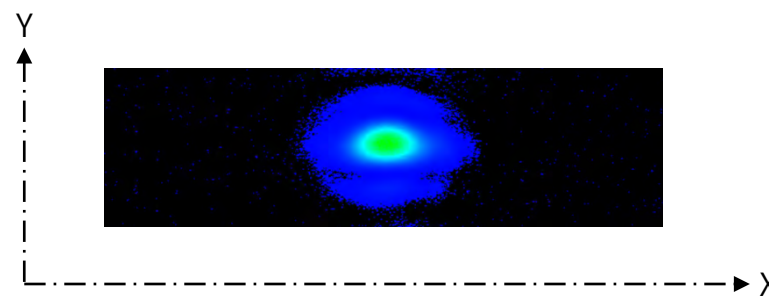

Emitter size

	FWHM (μm)	1/e (μm)	1/e ² (μm)
X	1.3	1.5	2.4
Y	0.7	0.9	1.2

X Profile

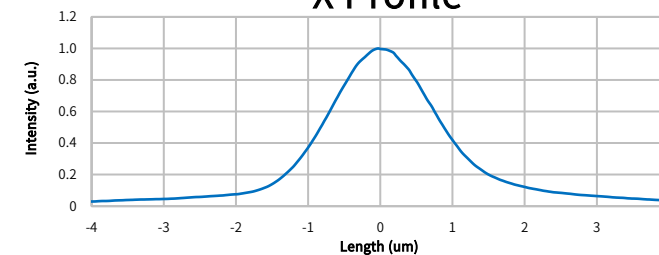

Y Profile

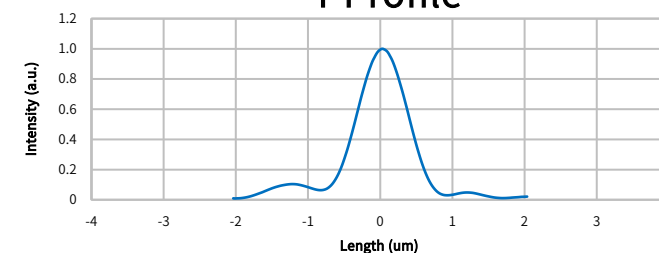



Characteristics

(Tc=25°C, CW)

Item	Conditions	Characteristic value (TYP.)
Wavelength (Peak)	Po=90mW	520nm
Output [Max]	—	90mW[95mW]
Threshold current	—	60mA
Operating current	Po=90mW	185mA
Operating voltage	Po=90mW	6.8V
Far Field (FWHM)	Po=90mW	θ// 7°, θ⊥ 23°
Terminal connections	No.8	
Package type	φ3.8	

CW I-L, I-V Temperature

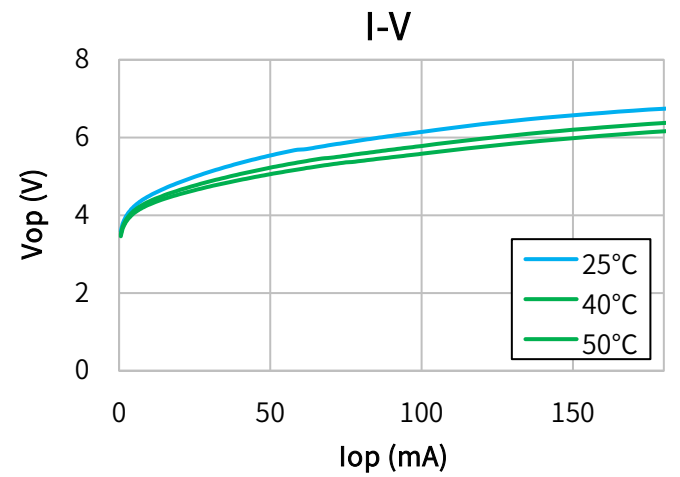
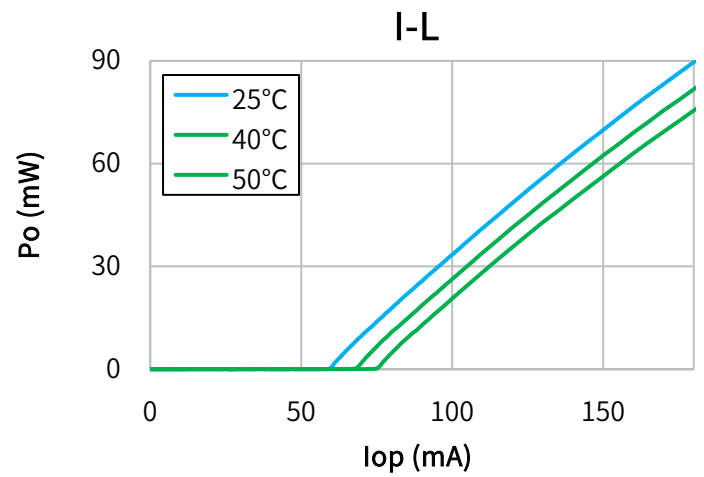

Far Field Pattern

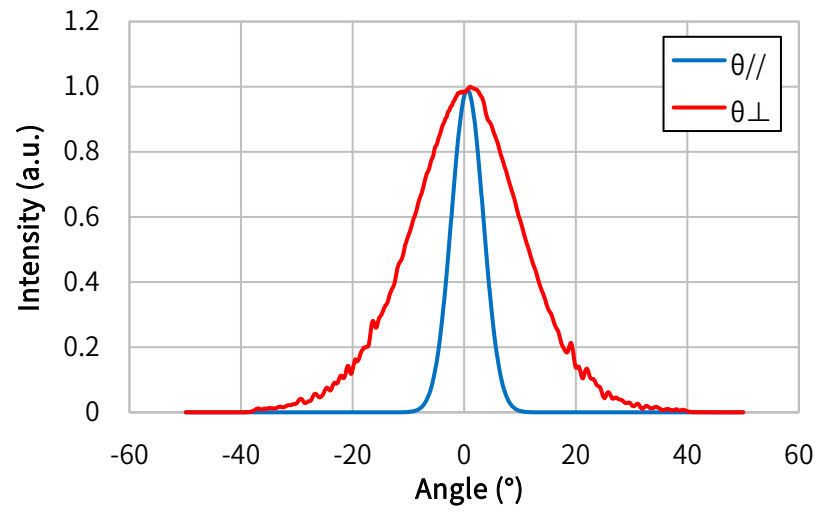

Near Field Pattern

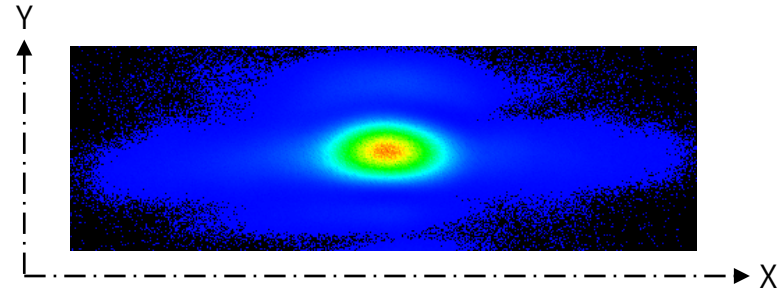

Emitter size

	FWHM (μm)	1/e (μm)	1/e ² (μm)
X	1.7	2.1	3.4
Y	0.8	0.9	1.3

X Profile

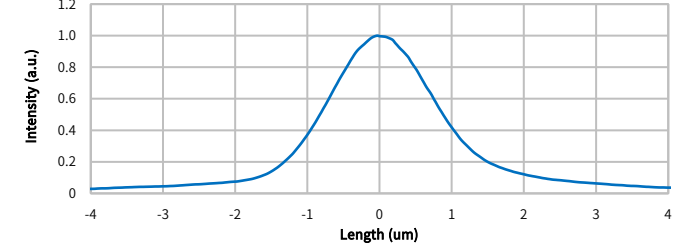

Y Profile

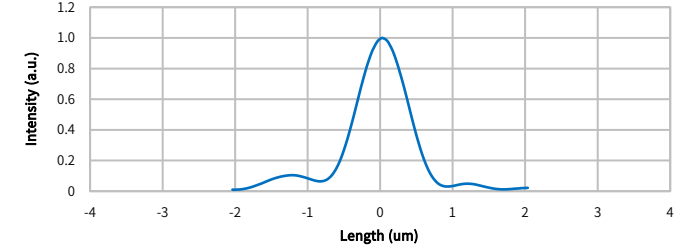



Characteristics

(Tc=25°C, CW)

Item	Conditions	Characteristic value (TYP.)
Wavelength (Peak)	Po=130mW	520nm
Output [Max]	—	130mW [135mW]
Threshold current	—	70mA
Operating current	Po=130mW	270mA
Operating voltage	Po=130mW	6.7V
Far Field (FWHM)	Po=130mW	θ// 8°, θ⊥ 22°

Terminal connections	No.8
Package type	φ5.6

CW I-L, I-V Temperature

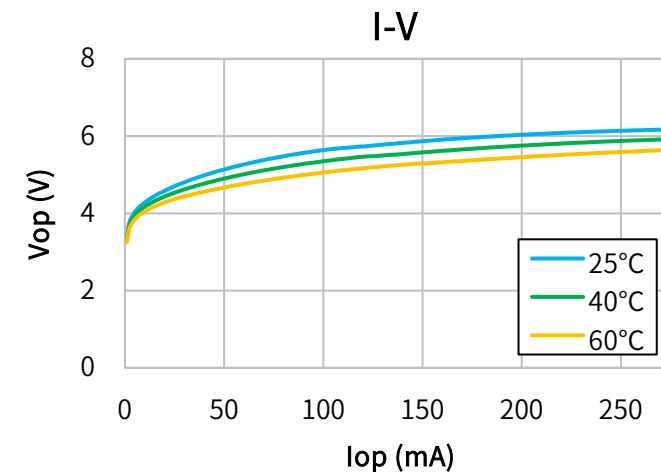
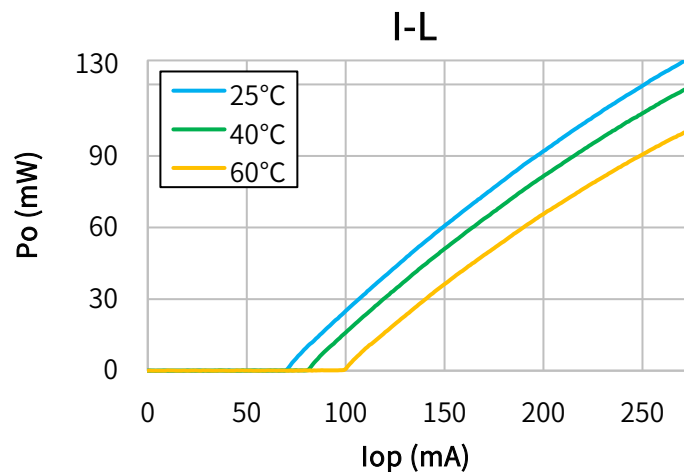

Far Field Pattern

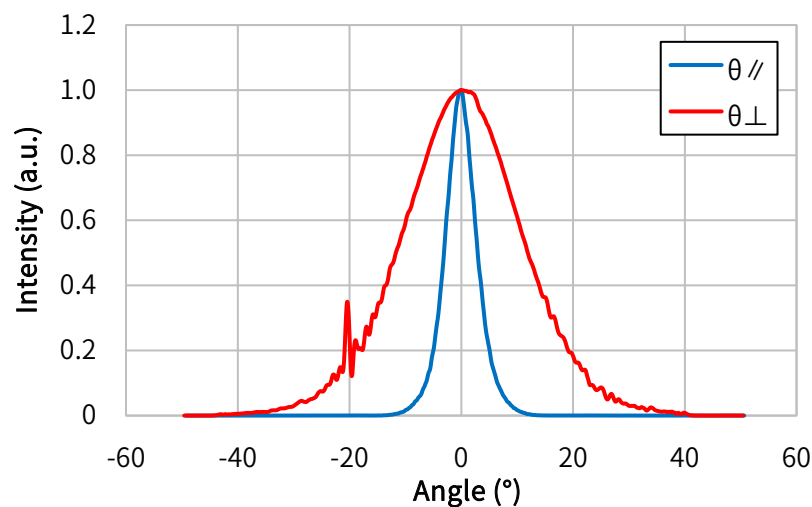

Near Field Pattern

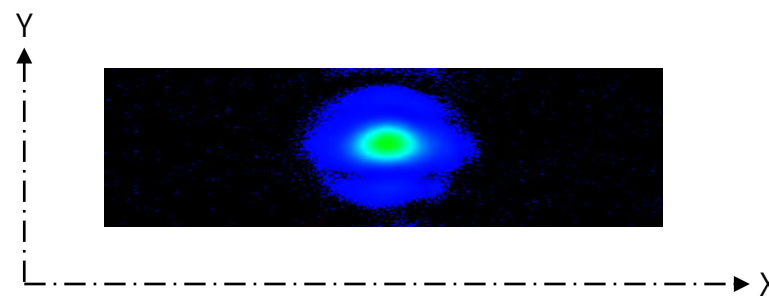

Emitter size

	FWHM (μm)	1/e (μm)	1/e ² (μm)
X	1.3	1.5	2.4
Y	0.7	0.9	1.2

X Profile

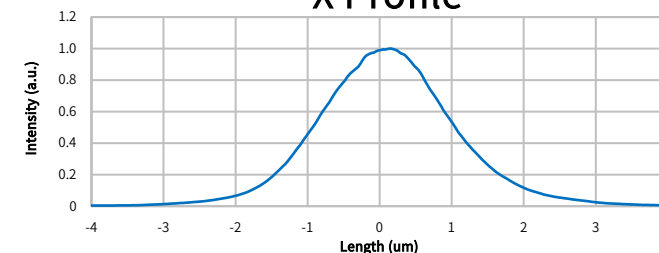

Y Profile

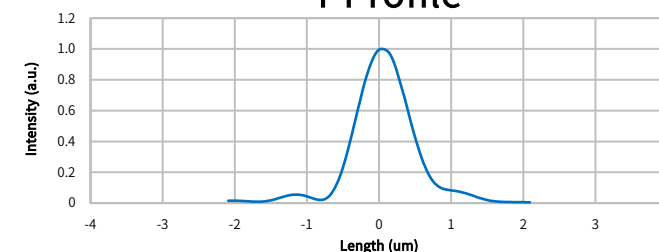



Characteristics

(Tc=25°C, CW)

Item	Conditions	Characteristic value (TYP.)
Wavelength (Peak)	Po=130mW	520nm
Output [Max]	—	130mW [135mW]
Threshold current	—	70mA
Operating current	Po=130mW	270mA
Operating voltage	Po=130mW	6.7V
Far Field (FWHM)	Po=130mW	θ// 8°, θ⊥ 22°
Terminal connections		No.8
Package type		φ3.8

CW I-L, I-V Temperature

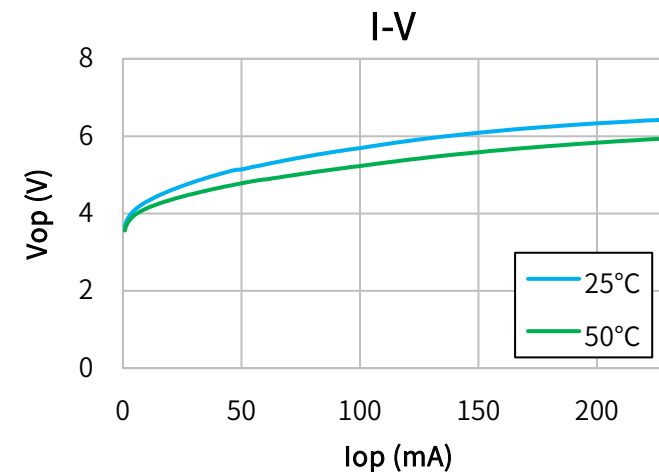
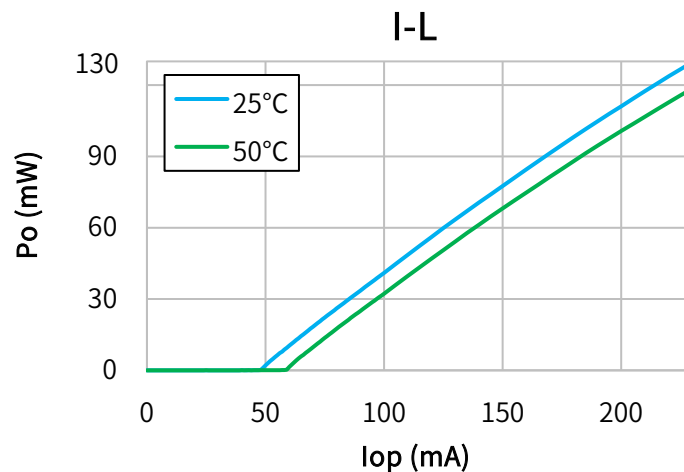

Far Field Pattern

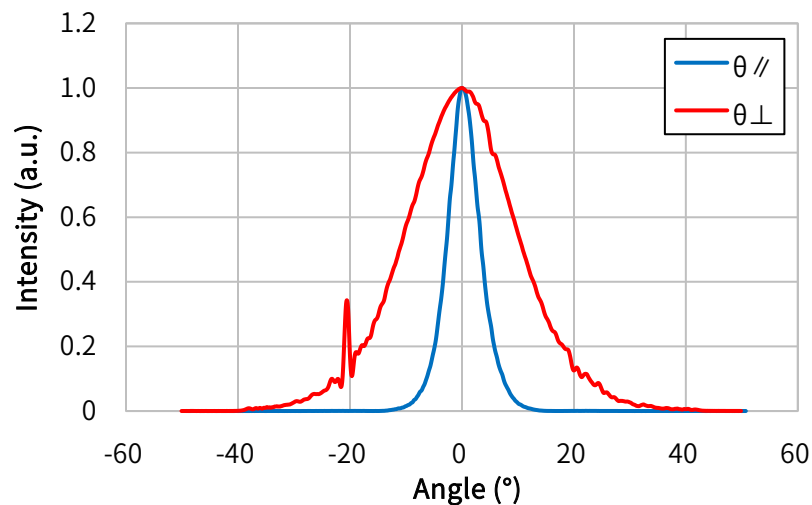

Near Field Pattern

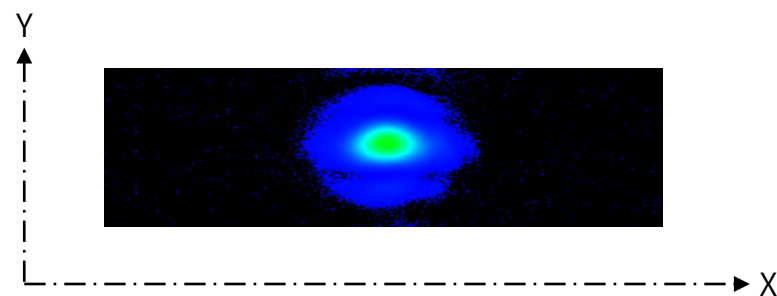

Emitter size

	FWHM (μm)	1/e (μm)	1/e ² (μm)
X	1.3	1.5	2.4
Y	0.7	0.9	1.2

X Profile

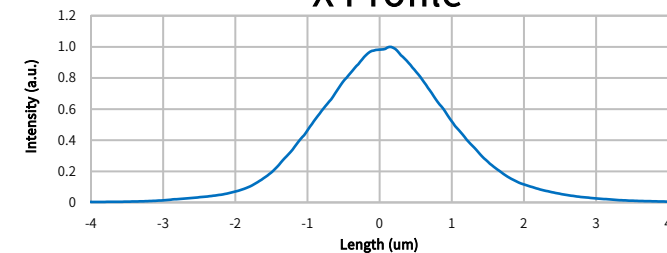

Y Profile

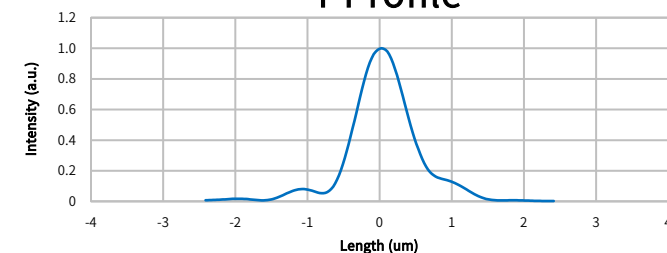



Characteristics

(Tc=25°C, CW)

Item	Conditions	Characteristic value (TYP.)
Wavelength (Peak)	Po=300mW	520nm
Output	—	300mW
Threshold current	—	100mA
Operating current	Po=300mW	500mA
Operating voltage	Po=300mW	5.2V
Far Field (FWHM)	Po=300mW	θ// 7°, θ⊥ 23°
Terminal connections	No.9	
Package type	φ5.6	

CW I-L, I-V Temperature

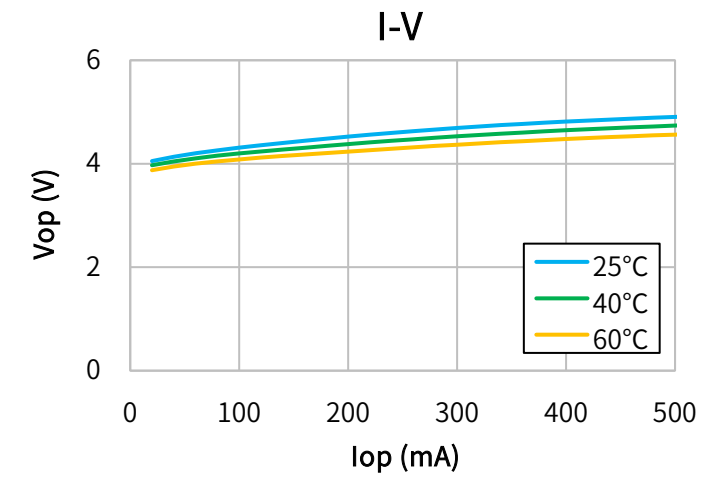
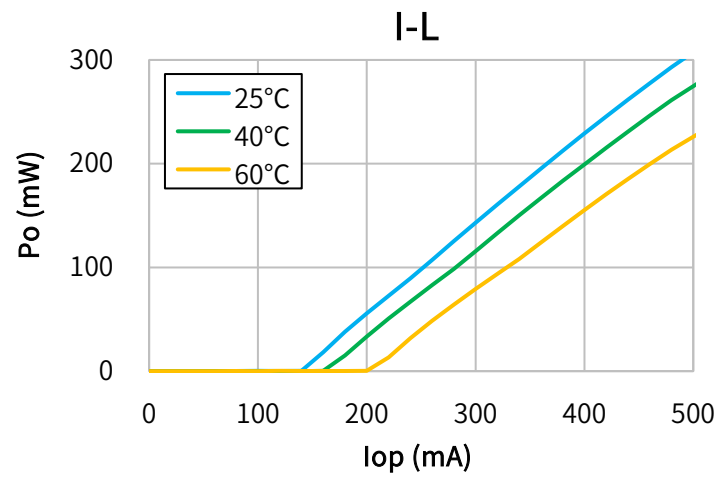

Far Field Pattern

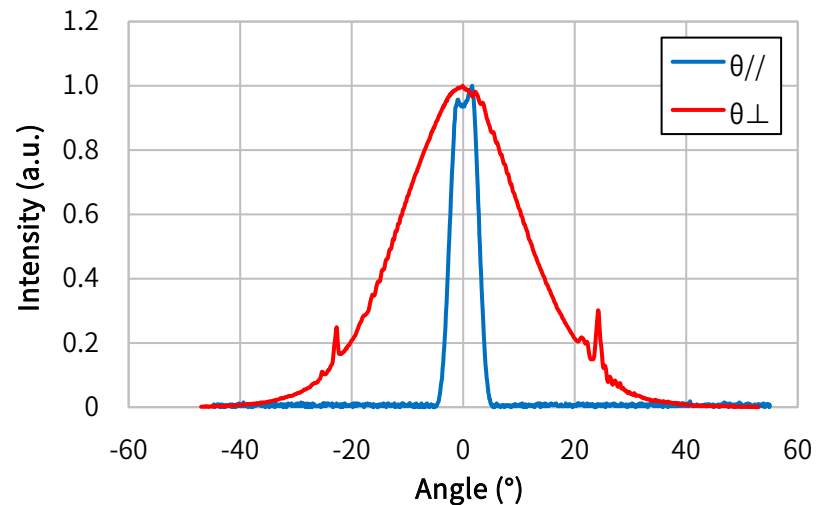

Near Field Pattern

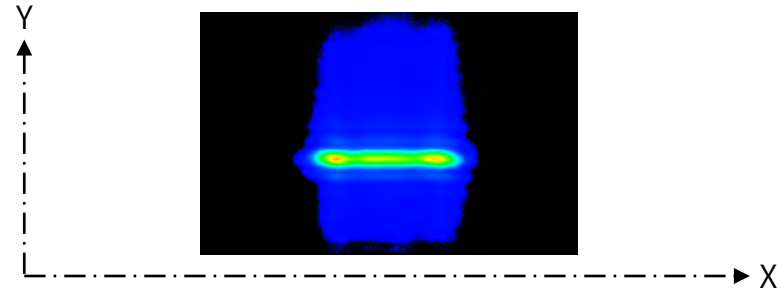

Emitter size

	FWHM (μm)	1/e (μm)	1/e ² (μm)
X	13.6	14.2	15.6
Y	1.3	1.6	2.2

X Profile

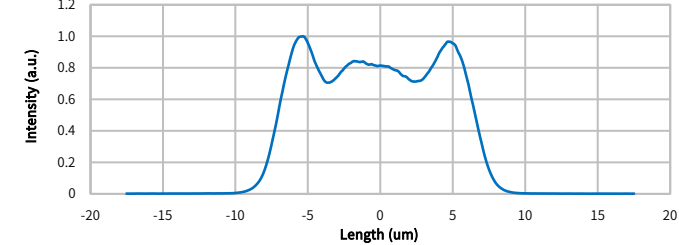

Y Profile

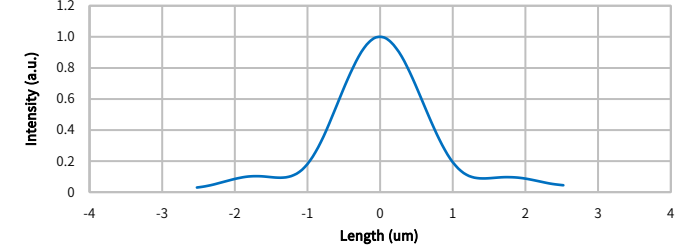



Characteristics

(Tc=25°C, CW)

Item	Conditions	Characteristic value (TYP.)
Wavelength (Peak)	Po=1000mW	520nm
Output	—	1000mW
Threshold current	—	210mA
Operating current	Po=1000mW	1400mA
Operating voltage	Po=1000mW	5.2V
Far Field (1/e ²)	Po=1000mW	θ// 8°, θ⊥ 41°
Terminal connections	No.9	
Package type	φ9.0	

CW I-L, I-V Temperature

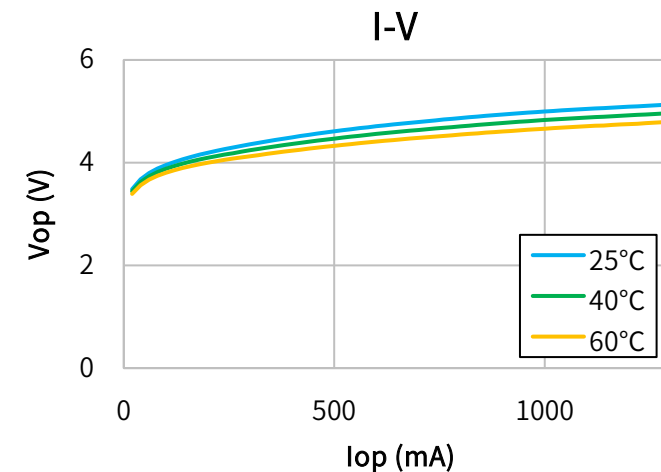
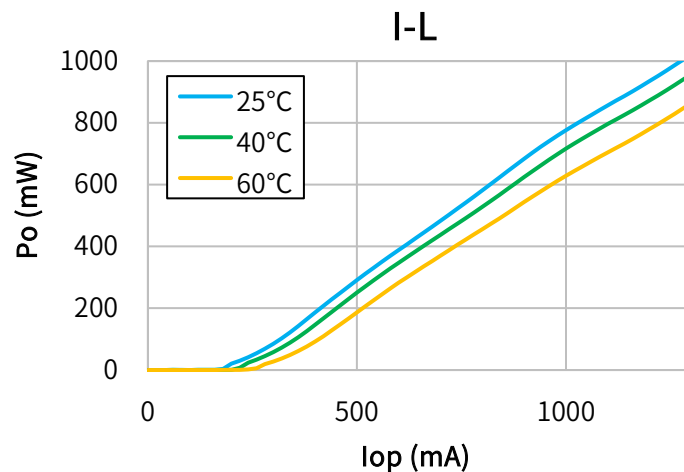

Far Field Pattern

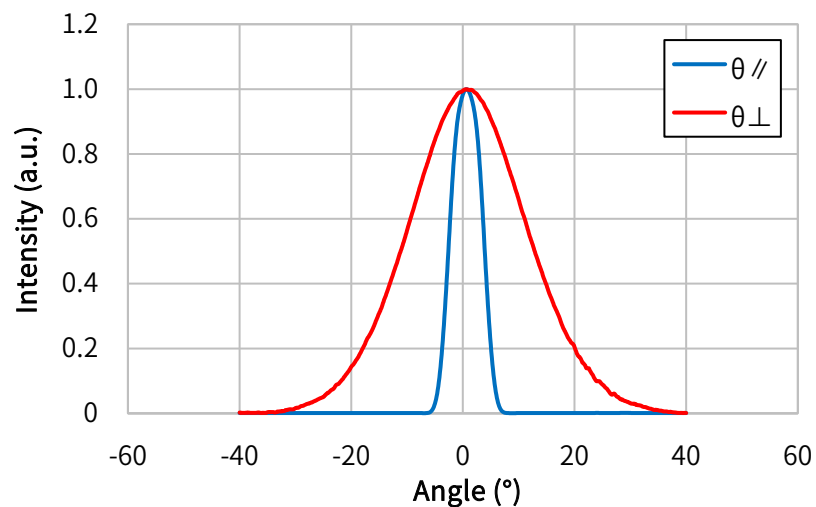

Near Field Pattern

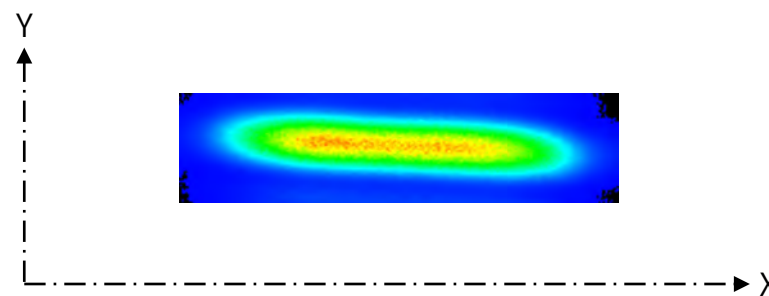

Emitter size

	FWHM (μm)	1/e (μm)	1/e ² (μm)
X	12.8	13.7	15.7
Y	1.5	1.8	2.5

X Profile

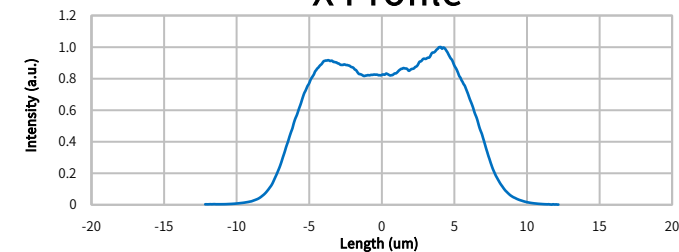

Y Profile

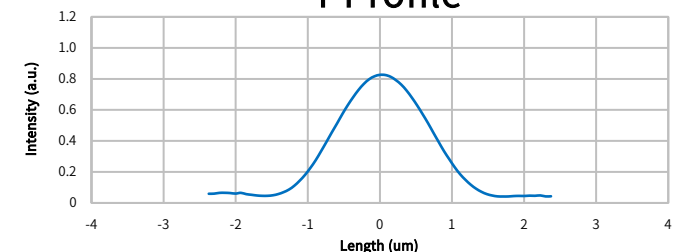



Characteristics

(T_c=25°C, CW)

Item	Conditions	Characteristic value (TYP.)
Wavelength (Peak)	P _o =30mW	638nm
Output	—	30mW
Threshold current	—	30mA
Operating current	P _o =30mW	50mA
Operating voltage	P _o =30mW	2.3V
Far Field (FWHM)	P _o =30mW	θ// 7°, θ⊥ 16°
Terminal connections	No.8	
Package type	φ5.6	

CW I-L, I-V Temperature

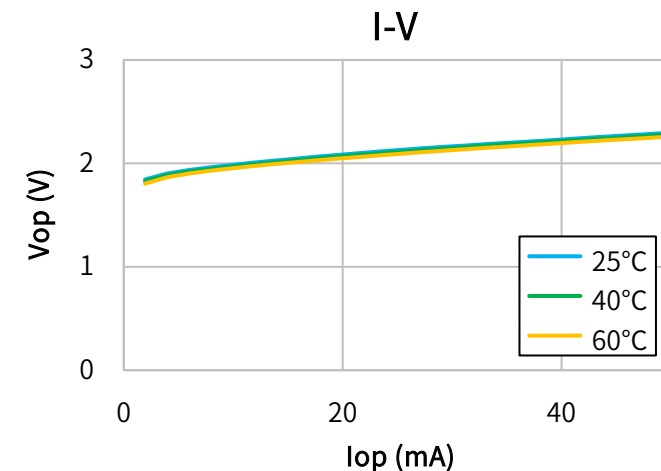
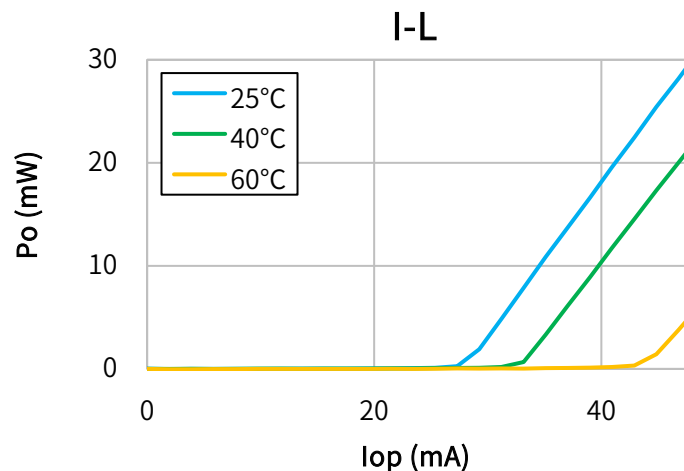

Far Field Pattern

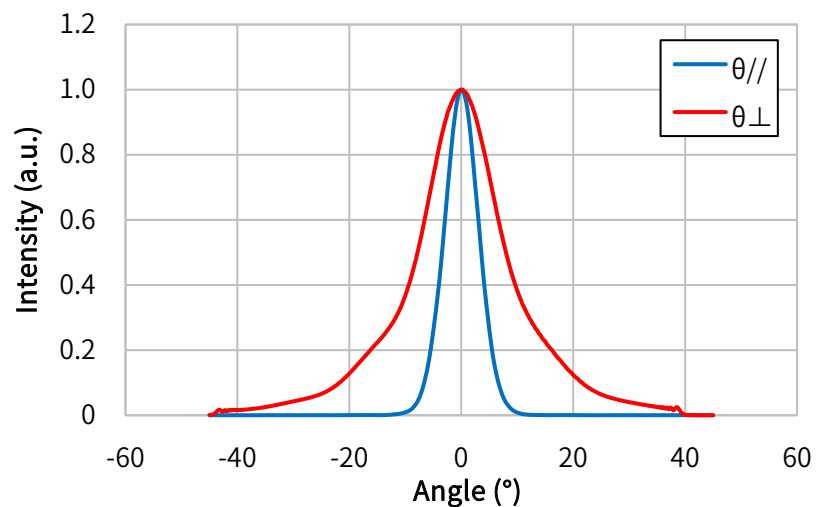

Near Field Pattern

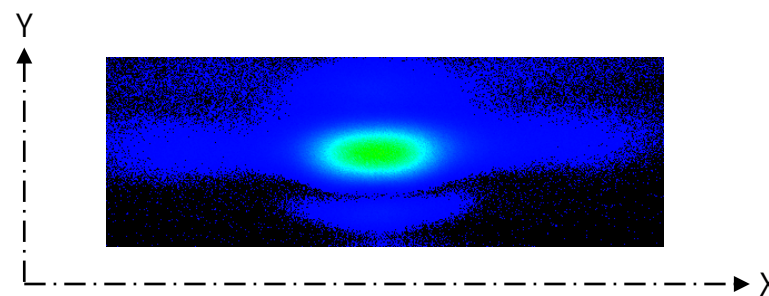

Emitter size

	FWHM (μm)	1/e (μm)	1/e ² (μm)
X	2.3	2.8	4.0
Y	0.9	1.1	1.5

X Profile

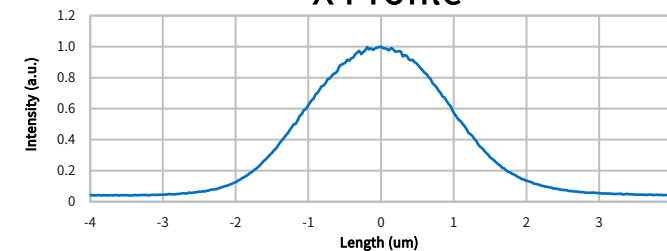

Y Profile

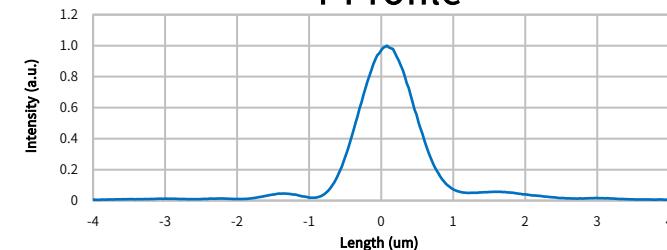



Characteristics

(Tc=25°C, CW)

Item	Conditions	Characteristic value (TYP.)
Wavelength (Peak)	Po=100mW	638nm
Output	—	100mW
Threshold current	—	50mA
Operating current	Po=100mW	130mA
Operating voltage	Po=100mW	2.5V
Far Field (FWHM)	Po=100mW	$\theta_{//} 8^\circ, \theta_{\perp} 15^\circ$
Terminal connections	No.6	
Package type	t1.8	

CW I-L, I-V Temperature

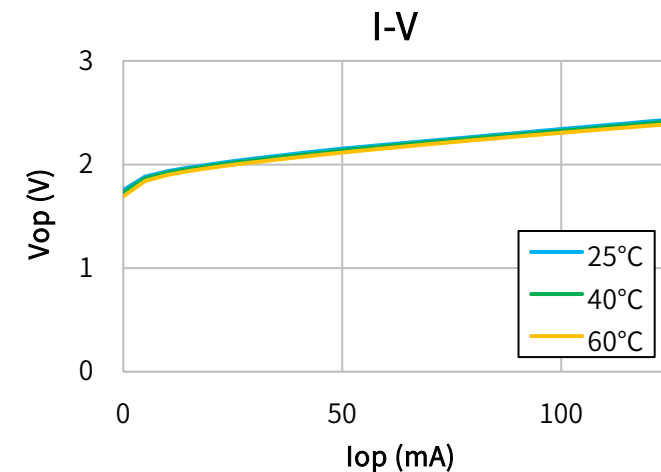
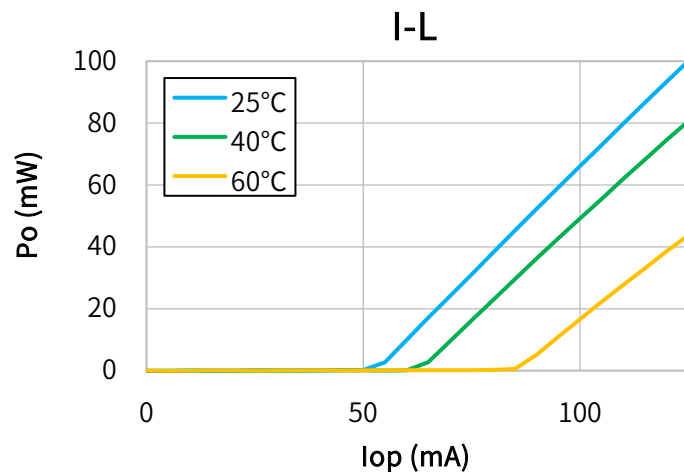

Far Field Pattern

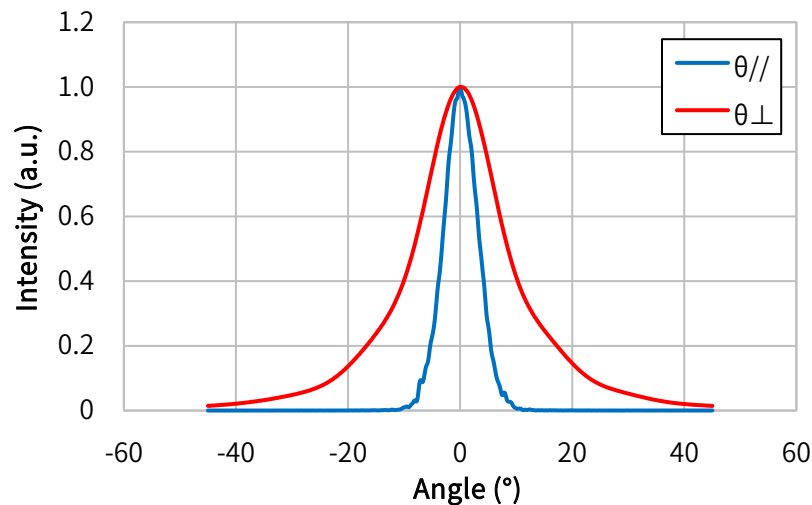

Near Field Pattern

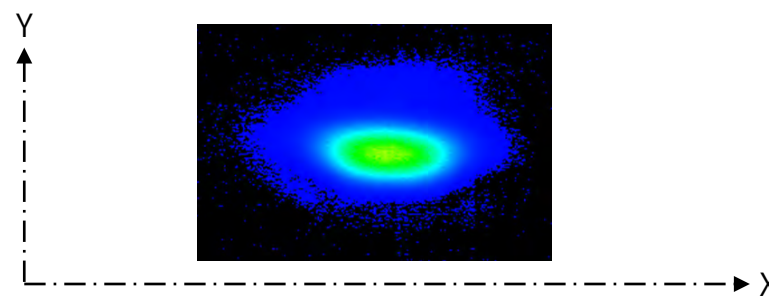

Emitter size

	FWHM (μm)	$1/e^2$ (μm)
X	2.0	3.2
Y	0.8	1.3

X Profile

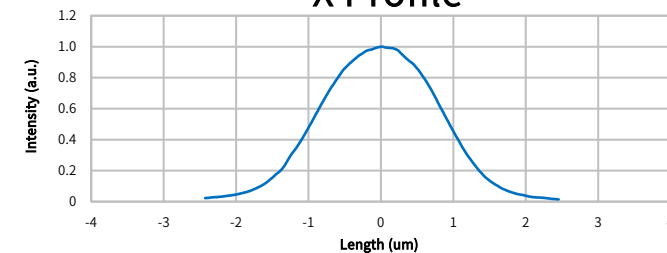

Y Profile

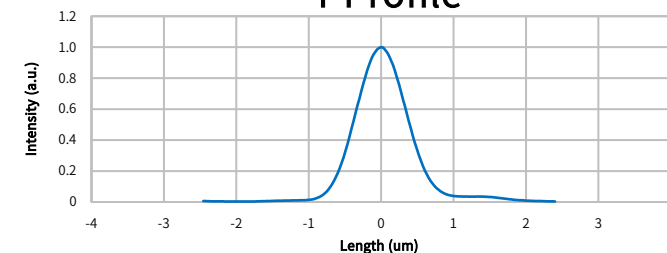



[↩ To the Wavelength](#)

[↩ To the Package](#)

[✉ Contact](#)

Characteristics

(Tc=25°C, CW)

Item	Conditions	Characteristic value (TYP.)
Wavelength (Peak)	Po=120mW	638nm
Output [Max]	—	120mW [120mW]
Threshold current	—	50mA
Operating current	Po=120mW	150mA
Operating voltage	Po=120mW	2.5V
Far Field (FWHM)	Po=120mW	θ// 8°, θ⊥ 15°

Terminal connections	No.8
Package type	φ3.8

CW I-L, I-V Temperature

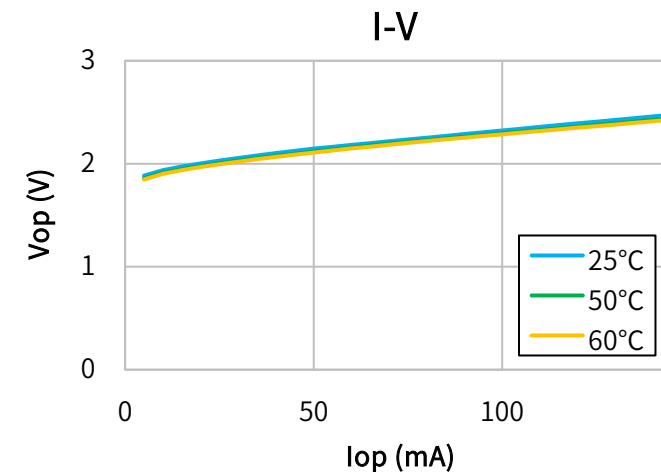
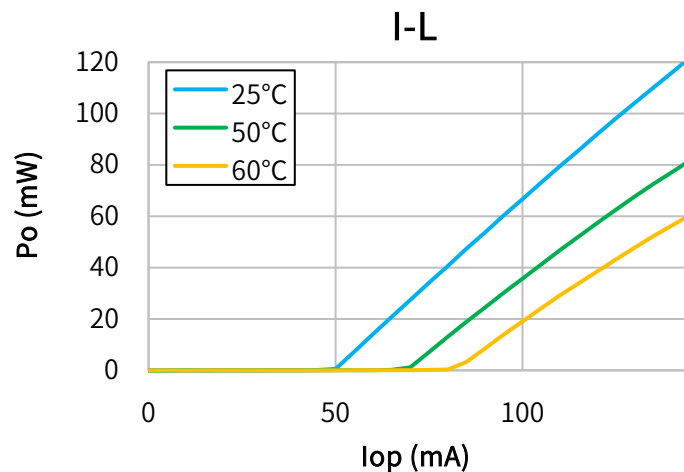

Far Field Pattern

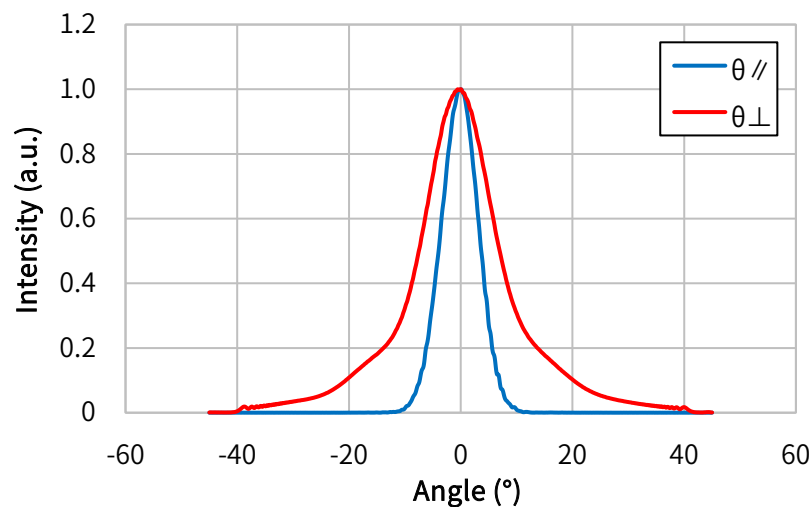

Near Field Pattern

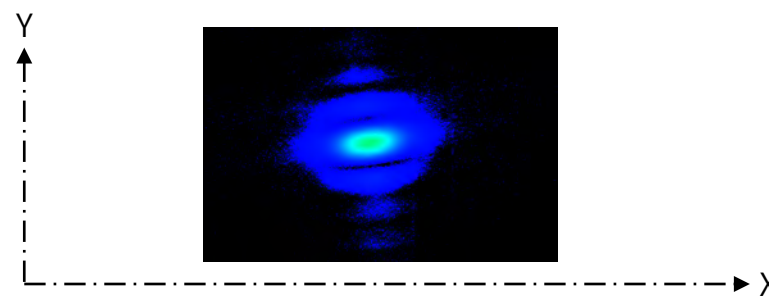

Emitter size

	FWHM (μm)	1/e ² (μm)
X	2.4	4.5
Y	1.1	1.7

X Profile

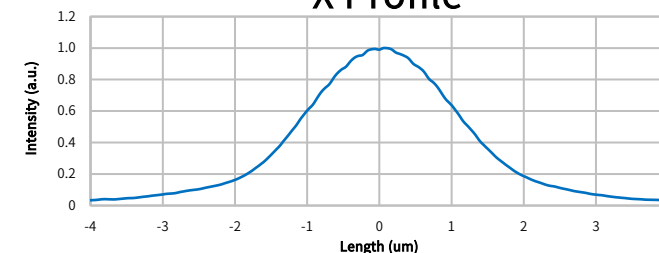

Y Profile

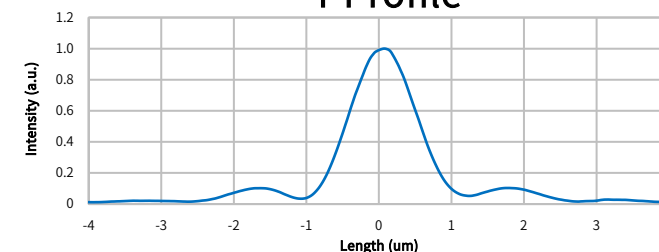



Characteristics

(Tc=25°C, CW)

Item	Conditions	Characteristic value (TYP.)
Wavelength (Peak)	Po=150mW	638nm
Output [Max]	—	150mW [185mW]
Threshold current	—	60mA
Operating current	Po=150mW	190mA
Operating voltage	Po=150mW	2.5V
Far Field (FWHM)	Po=150mW	$\theta_{//}$ 7.5°, θ_{\perp} 15°

Terminal connections	No.8
Package type	φ3.8

CW I-L, I-V Temperature

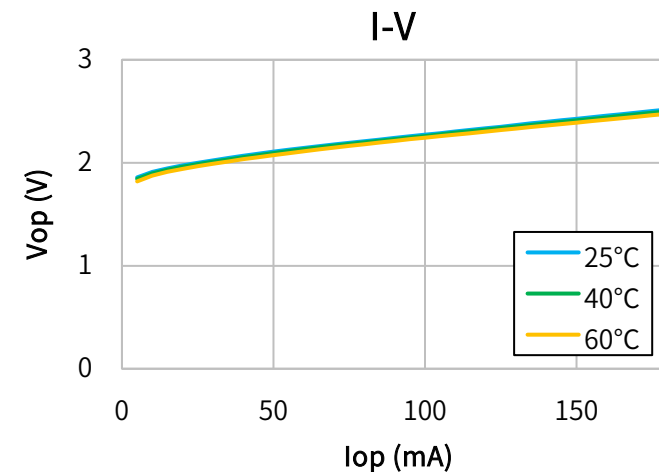
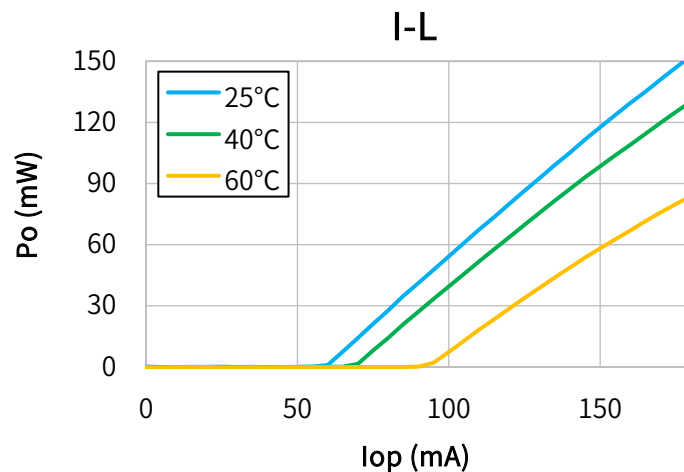

Far Field Pattern

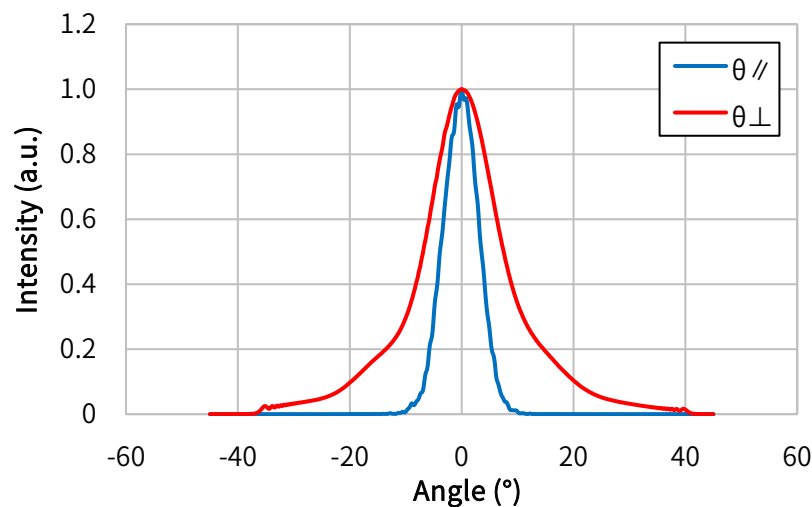

Near Field Pattern

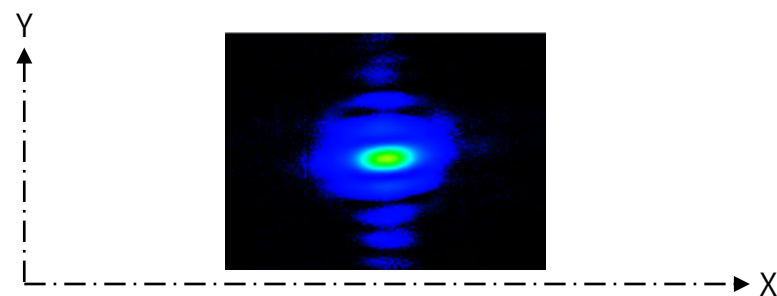

Emitter size

	FWHM (μm)	1/e ² (μm)
X	2.3	4.1
Y	1.0	1.6

X Profile

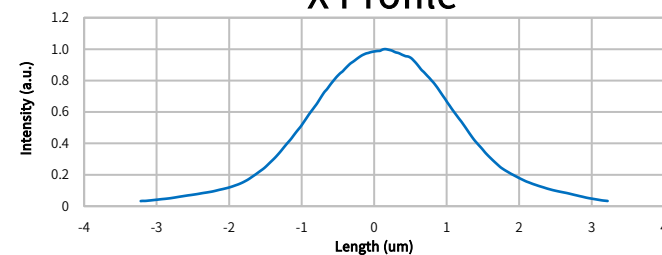

Y Profile

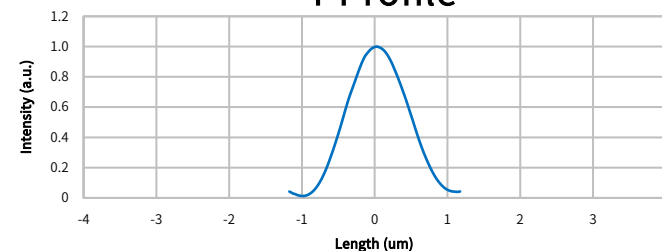



Characteristics

(T_c=25°C, CW)

Item	Conditions	Characteristic value (TYP.)
Wavelength (Peak)	Po=700mW	638nm
Output [Max]	—	700mW
Threshold current	—	110mA
Operating current	Po=700mW	810mA
Operating voltage	Po=700mW	2.5V
Far Field (FWHM)	Po=700mW	θ// 16°, θ⊥ 35°
Terminal connections	No.9	
Package type	φ5.6	

CW I-L, I-V Temperature

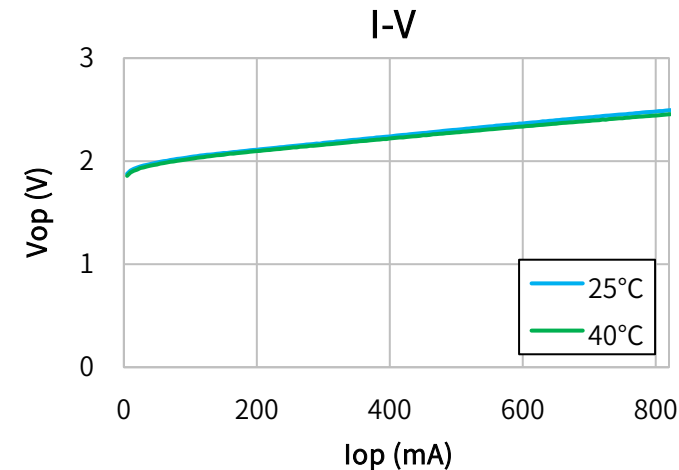
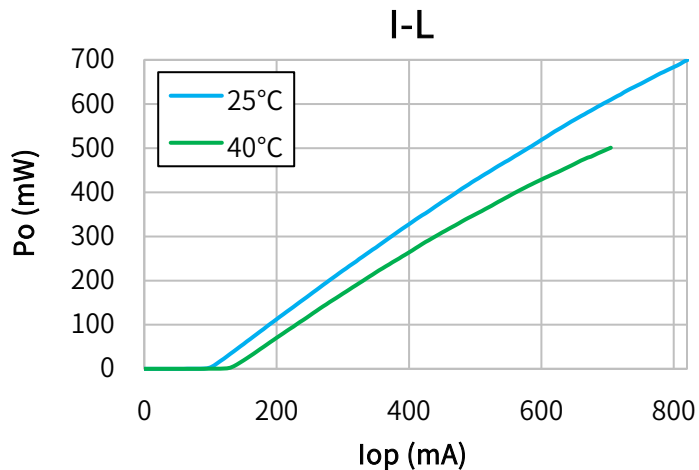

Far Field Pattern

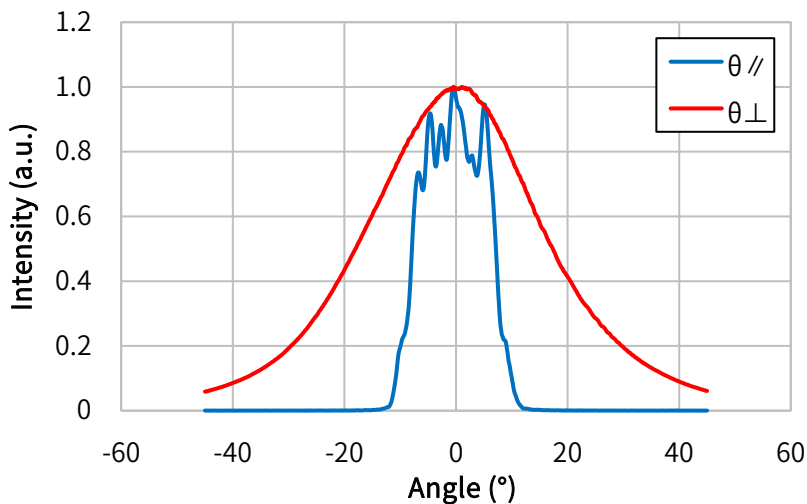

Near Field Pattern

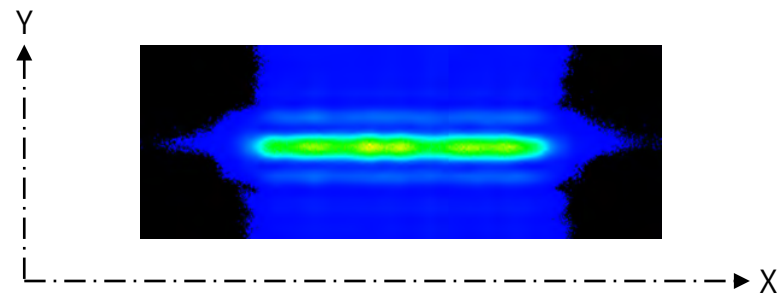

Emitter size

	FWHM (μm)	1/e (μm)	1/e ² (μm)
X	19.5	20.4	22.9
Y	1.2	1.5	2.1

X Profile

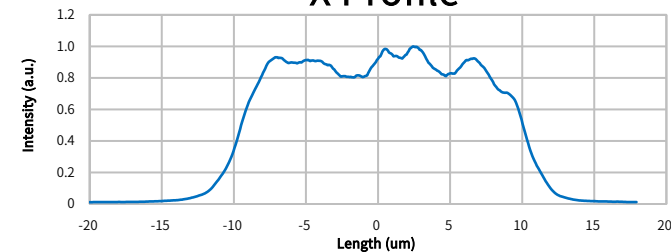

Y Profile

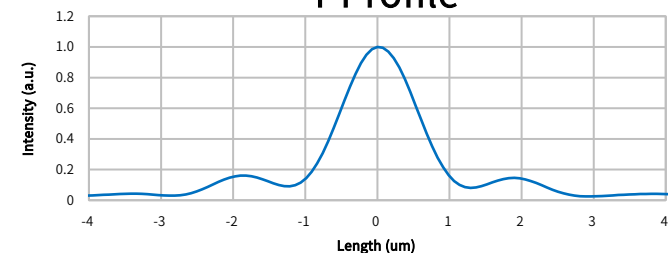



Characteristics

(Tc=25°C, CW)

Item	Conditions	Characteristic value (TYP.)
Wavelength (Peak)	Po=180mW	639nm
Output [Max]	—	180mW [185mW]
Threshold current	—	55mA
Operating current	Po=180mW	215mA
Operating voltage	Po=180mW	2.7V
Far Field (FWHM)	Po=180mW	$\theta_{//} 8^\circ, \theta_{\perp} 15^\circ$

Terminal connections	No.9
Package type	φ5.6

CW I-L, I-V Temperature

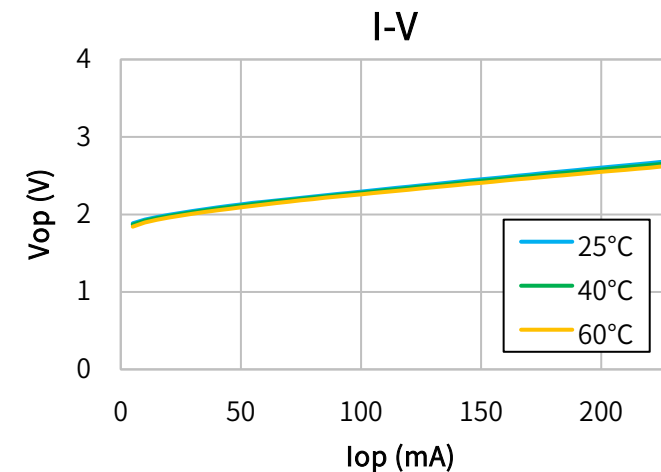
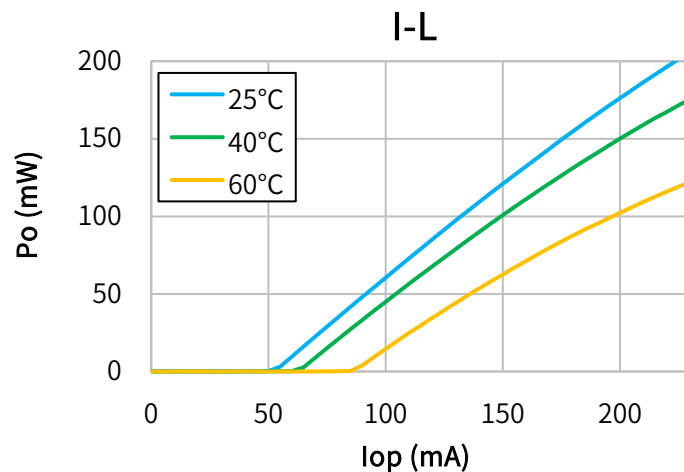

Far Field Pattern

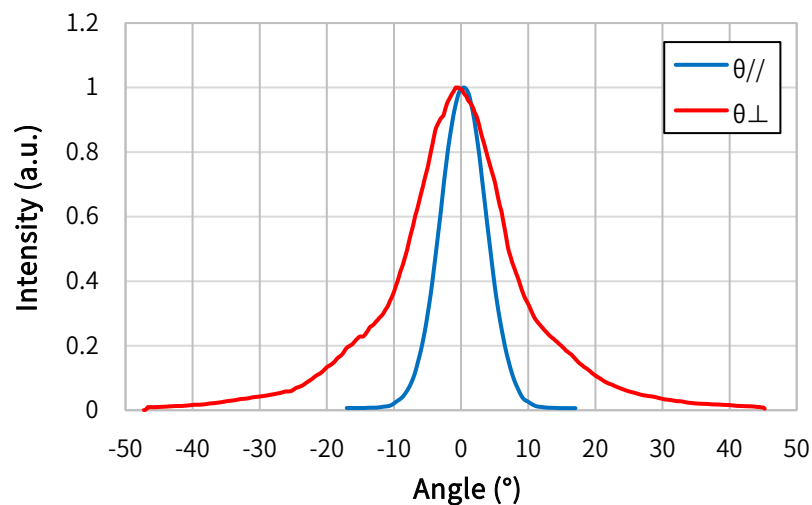

Near Field Pattern

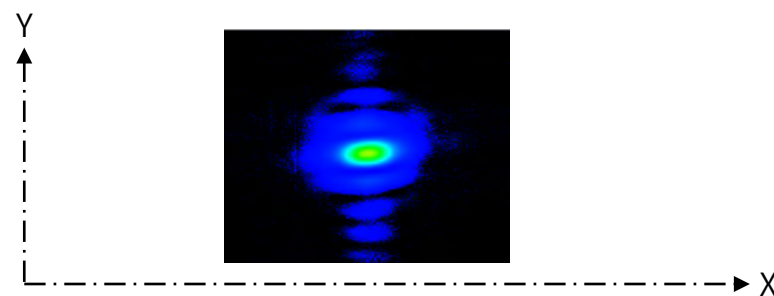

Emitter size

	FWHM (μm)	1/e ² (μm)
X	2.3	4.1
Y	1.0	1.6

X Profile

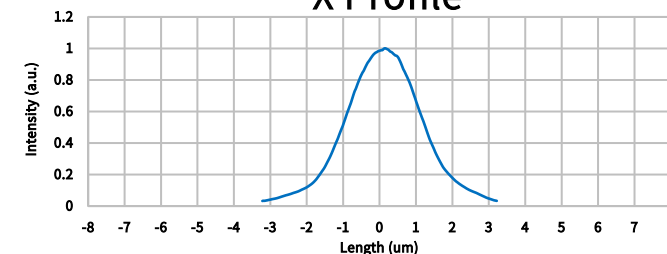

Y Profile

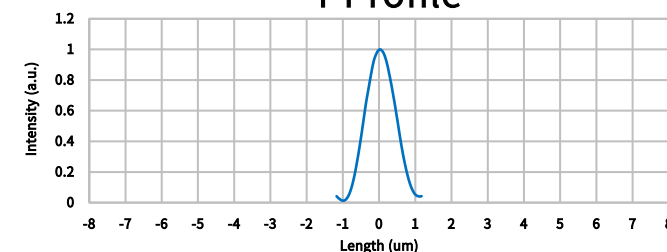



Characteristics

(Tc=25°C, CW)

Item	Conditions	Characteristic value (TYP.)
Wavelength (Peak)	Po=1200mW	640nm
Output	—	1200mW
Threshold current	—	350mA
Operating current	Po=1200mW	1400mA
Operating voltage	Po=1200mW	2.3V
Far Field (FWHM)	Po=1200mW	θ// 11°, θ⊥ 35°
Terminal connections	No.9	
Package type	φ9.0	

CW I-L, I-V Temperature

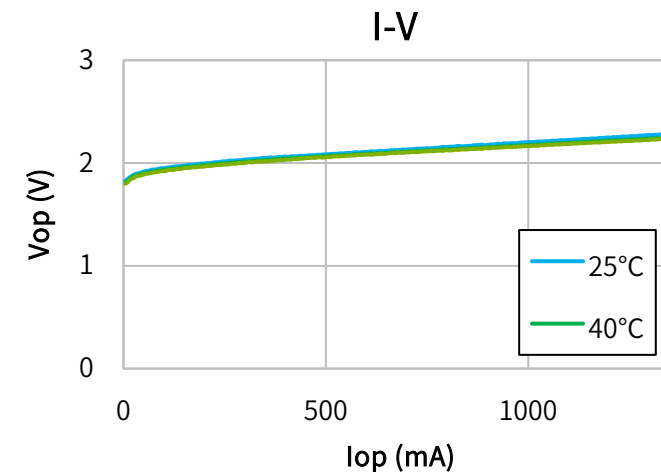
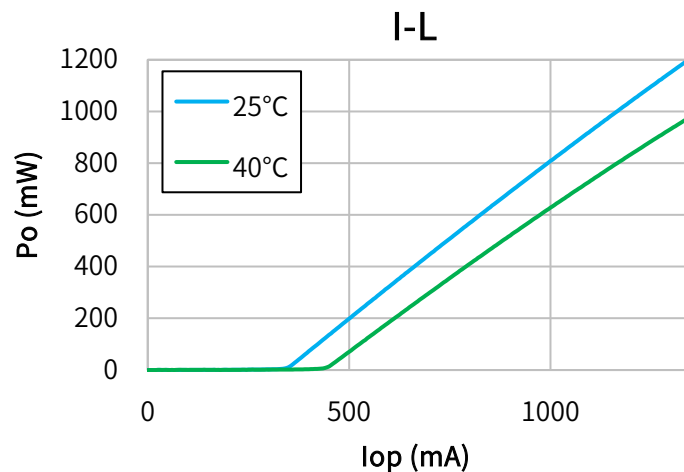

Far Field Pattern

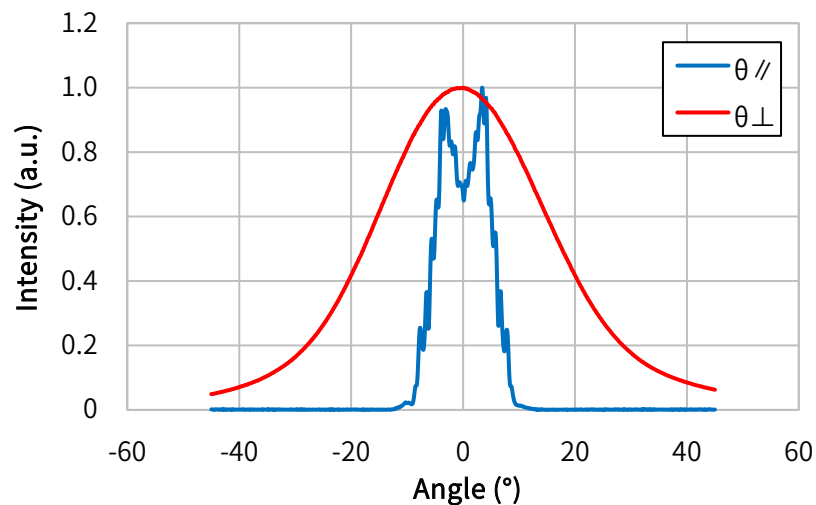

Near Field Pattern

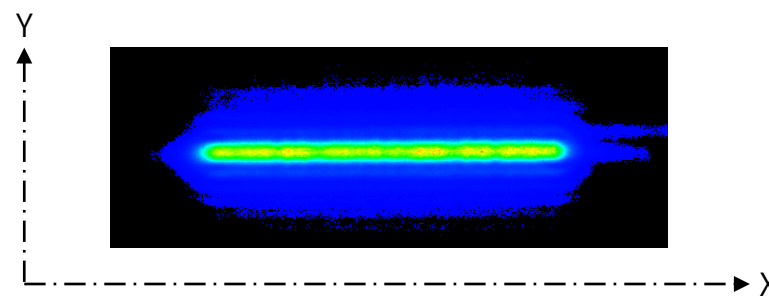

Emitter size

	FWHM (μm)	1/e (μm)	1/e ² (μm)
X	83.5	85.0	89.6
Y	3.6	4.3	6.0

X Profile

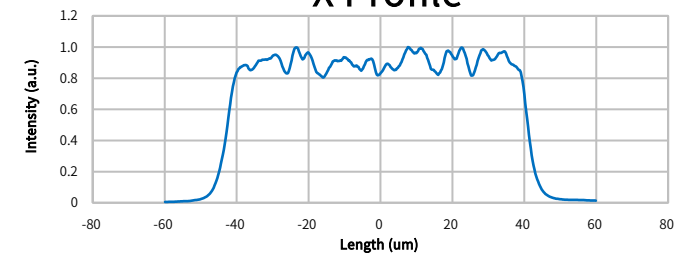

Y Profile

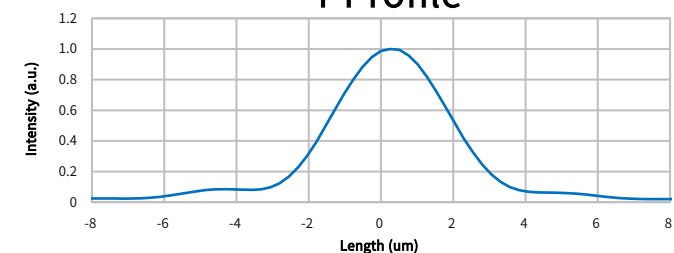



Characteristics

(Tc=25°C, CW)

Item	Conditions	Characteristic value (TYP.)
Wavelength (Peak)	Po=180mW	650nm
Output [Max]	—	180mW [185mW]
Threshold current	—	55mA
Operating current	Po=180mW	200mA
Operating voltage	Po=180mW	2.6V
Far Field (FWHM)	Po=180mW	θ// 8°, θ⊥ 12.5°

Terminal connections	No.9
Package type	φ5.6

CW I-L, I-V Temperature

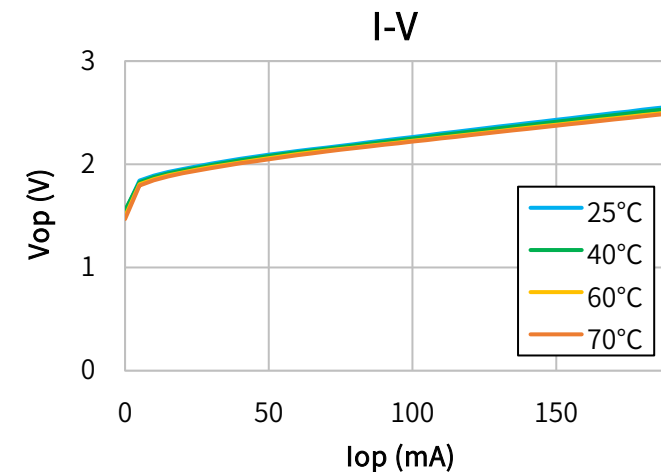
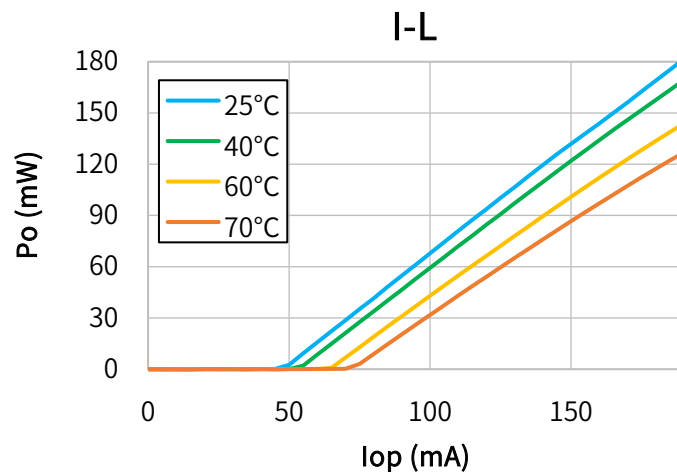

Far Field Pattern

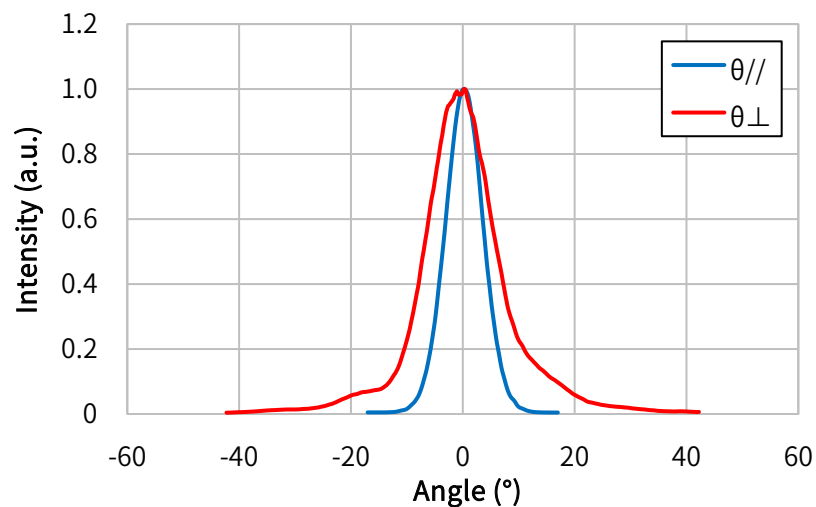

Near Field Pattern

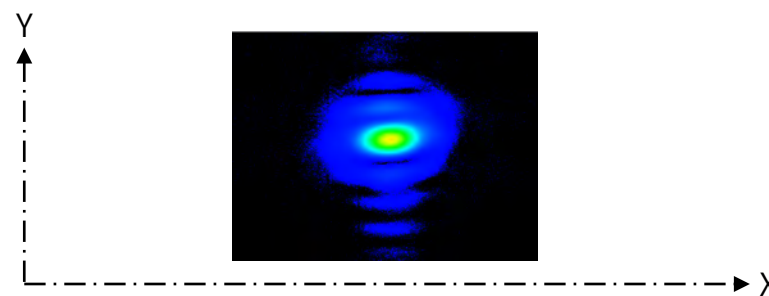

Emitter size

	FWHM (μm)	1/e ² (μm)
X	2.3	4.3
Y	1.2	2.0

X Profile

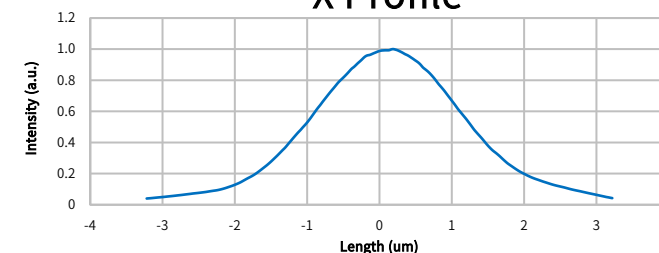

Y Profile

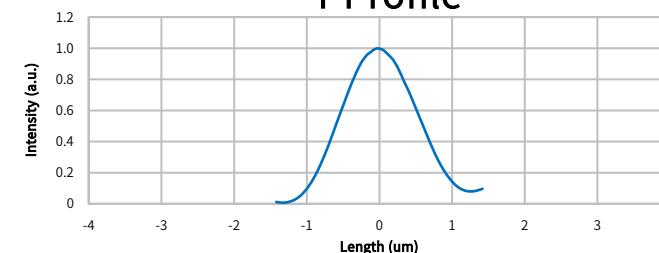



Characteristics

(Tc=25°C, CW)

Item	Conditions	Characteristic value (TYP.)
Wavelength (Peak)	Po=7mW	660nm
Output [Max]	—	7mW[10mW]
Threshold current	—	17mA
Operating current	Po=7mW	26mA
Operating voltage	Po=7mW	2.2V
Far Field (FWHM)	Po=7mW	θ// 13°, θ⊥ 28°
Terminal connections	No.1	
Package type	φ3.3	

CW I-L, I-V Temperature

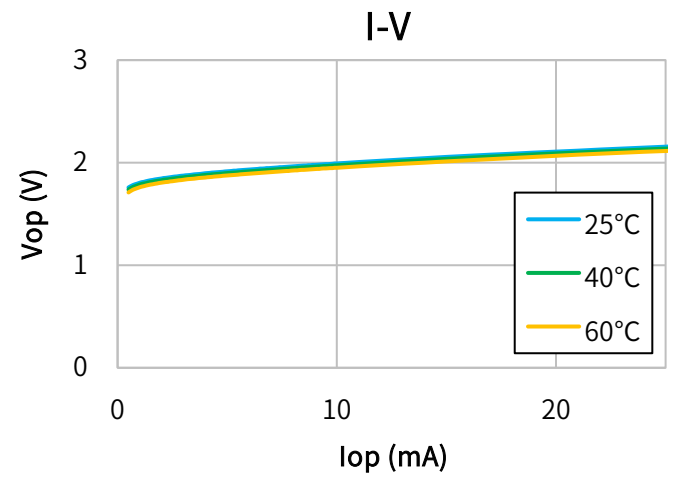
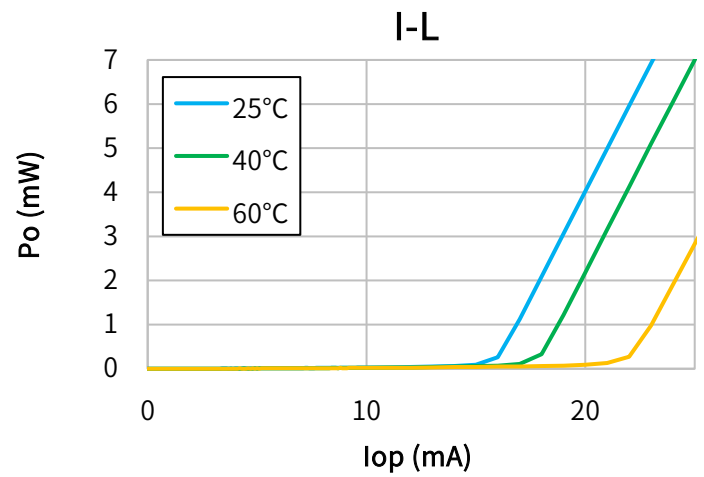

Far Field Pattern

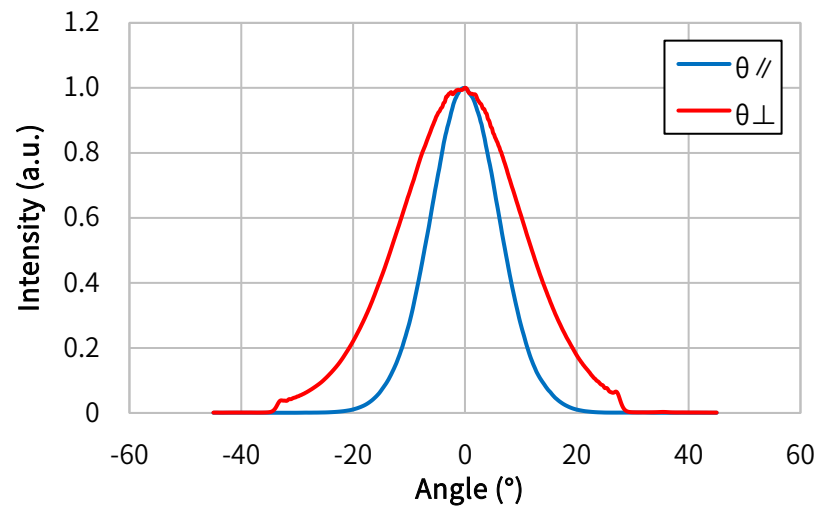

Near Field Pattern

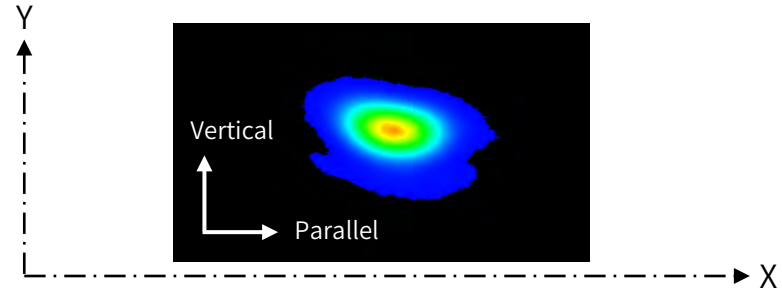

Emitter size

	FWHM (μm)	1/e ² (μm)
X	1.4	2.3
Y	0.7	1.2

X Profile

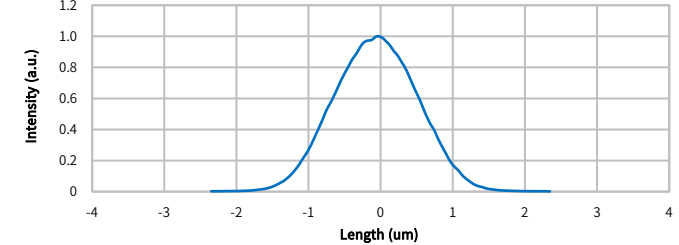

Y Profile

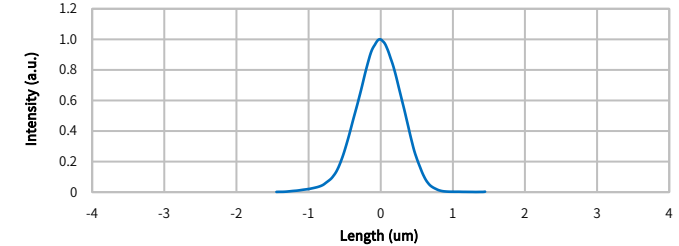



Characteristics

(Tc=25°C, CW)

Item	Conditions	Characteristic value (TYP.)
Wavelength (Peak)	Po=10mW	660nm
Output [Max]	—	10mW[12mW]
Threshold current	—	15mA
Operating current	Po=10mW	24mA
Operating voltage	Po=10mW	2.2V
Far Field (FWHM)	Po=10mW	θ// 12°, θ⊥ 33°
Terminal connections	No.4	
Package type	φ5.6	

CW I-L, I-V Temperature

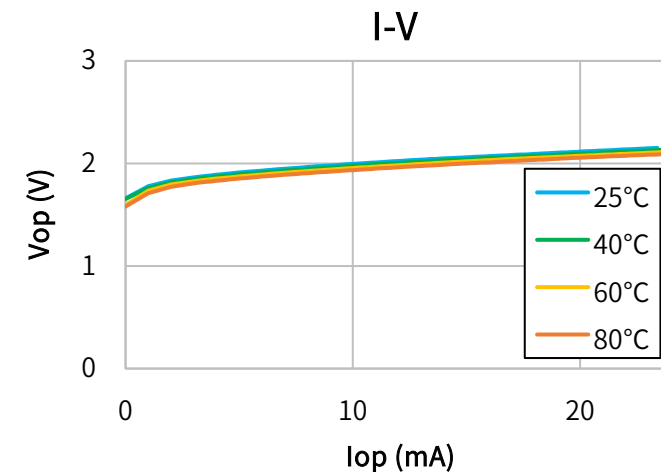
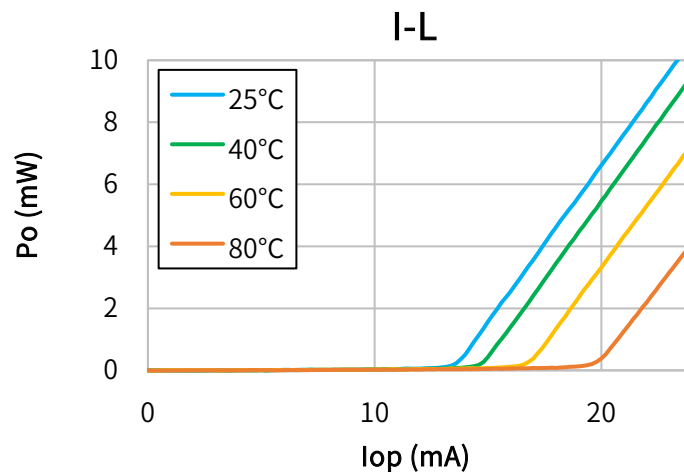

Far Field Pattern

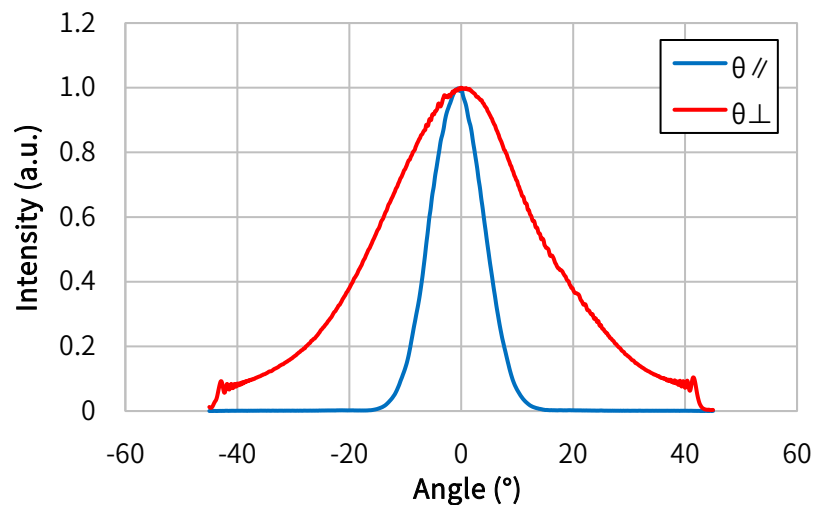

Near Field Pattern

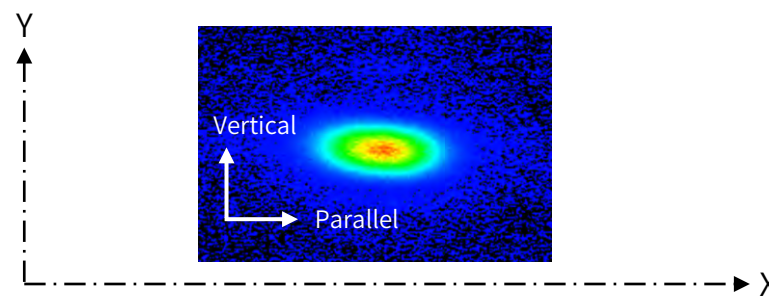

Emitter size

	FWHM (μm)	1/e ² (μm)
X	1.6	2.7
Y	0.7	1.1

X Profile

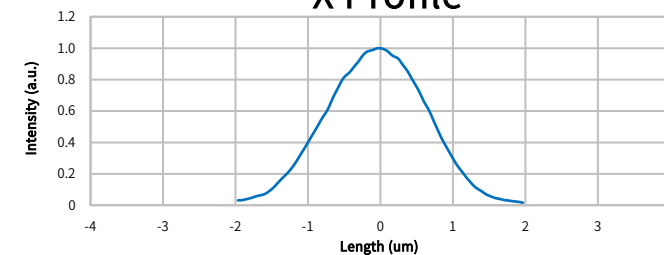

Y Profile

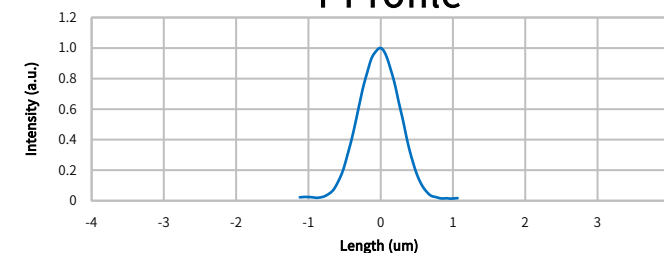



Characteristics

(Tc=25°C, CW)

Item	Conditions	Characteristic value (TYP.)
Wavelength (Peak)	Po=95mW	660nm
Output [Max]	—	95mW [100mW]
Threshold current	—	40mA
Operating current	Po=95mW	122mA
Operating voltage	Po=95mW	2.4V
Far Field (FWHM)	Po=95mW	θ// 10°, θ⊥ 15.5°

Terminal connections	No.3
Package Type	φ5.6

CW I-L, I-V Temperature

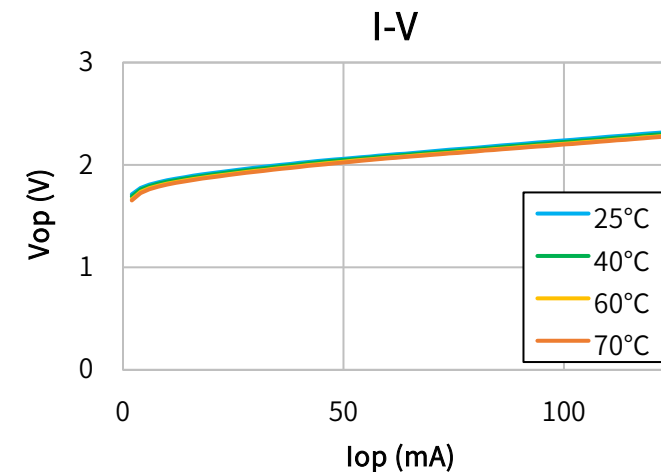
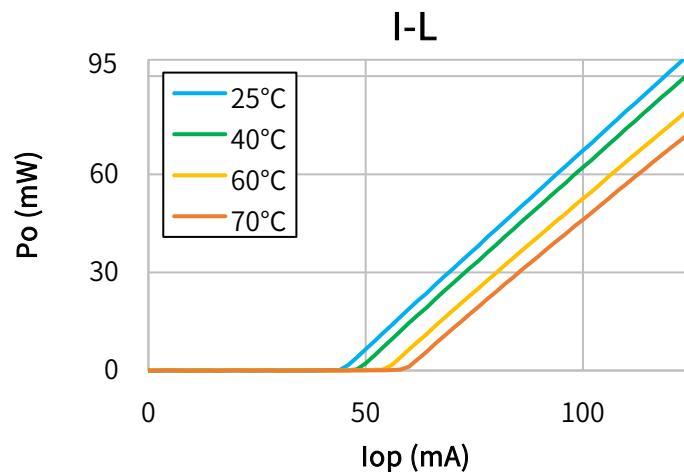

Far Field Pattern

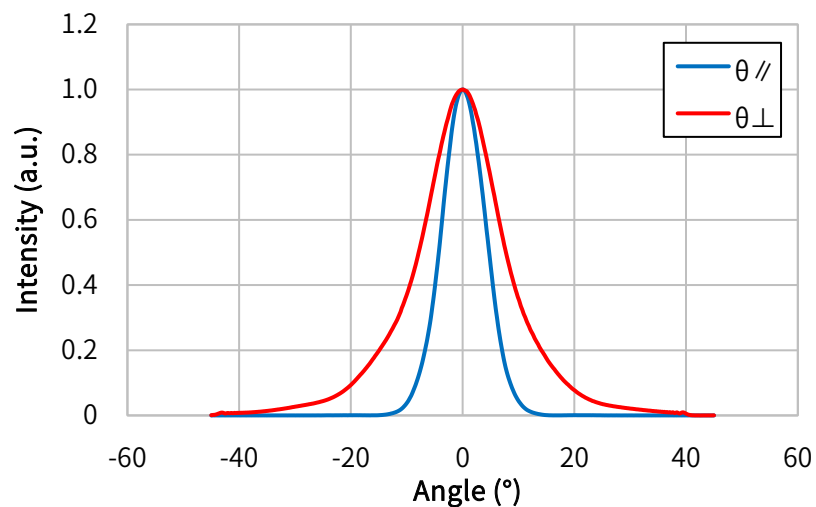

Near Field Pattern

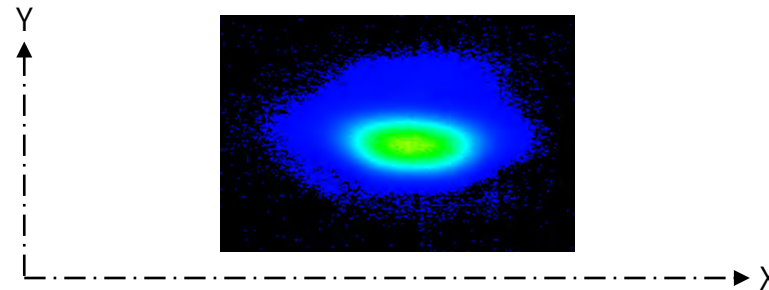

Emitter size

	FWHM (μm)	1/e ² (μm)
X	2.0	3.2
Y	0.8	1.3

X Profile

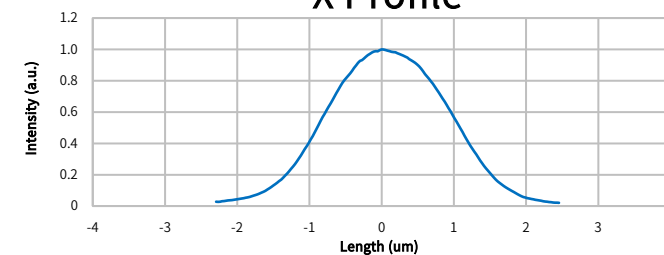

Y Profile

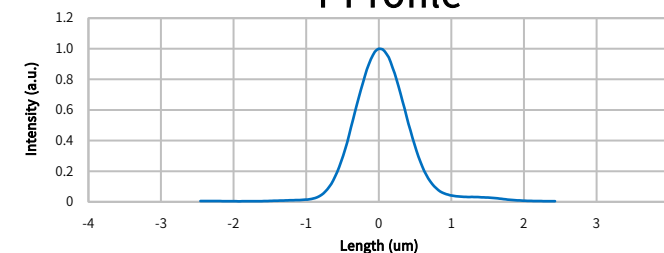



Characteristics

(Tc=25°C, CW)

Item	Conditions	Characteristic value (TYP.)
Wavelength (Peak)	Po=90mW	661nm
Output [Max]	—	90mW [100mW]
Threshold current	—	42mA
Operating current	Po=90mW	120mA
Operating voltage	Po=90mW	2.3V
Far Field (FWHM)	Po=90mW	$\theta_{//}$ 9.3°, θ_{\perp} 15°
Terminal connections		No.6
Package type		t1.8

CW I-L, I-V Temperature

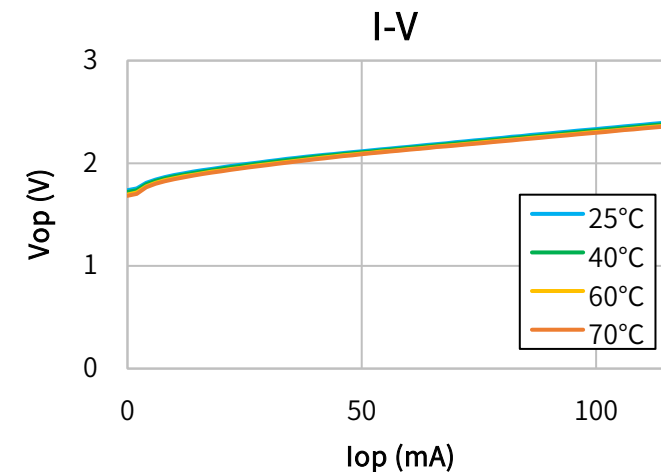
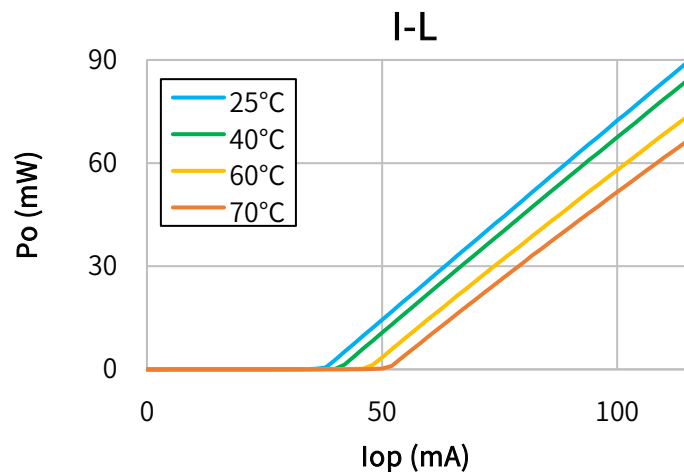

Far Field Pattern

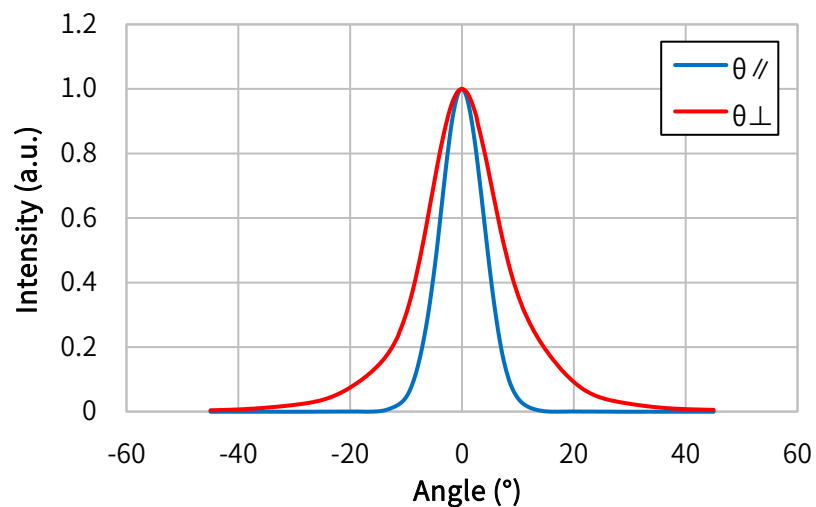

Near Field Pattern

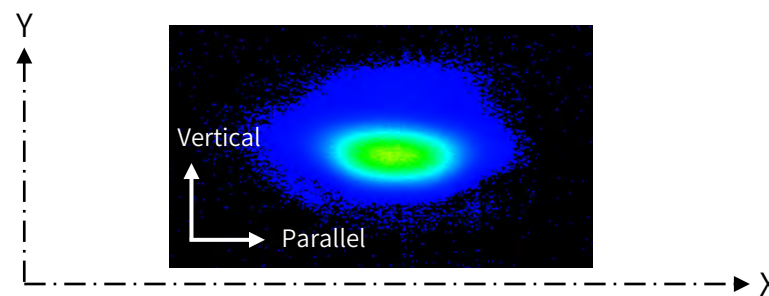

Emitter size

	FWHM (μm)	1/e ² (μm)
X	2.0	3.2
Y	0.8	1.3

X Profile

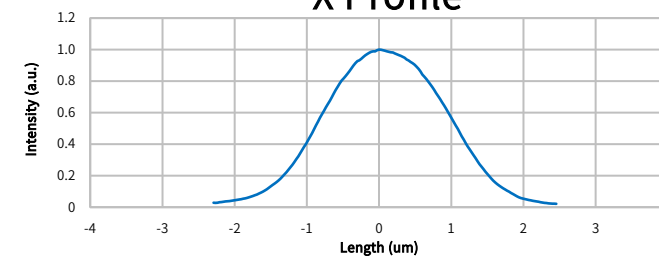

Y Profile

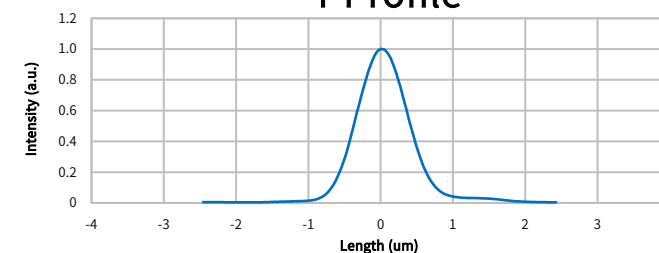



Characteristics

(Tc=25°C, CW)

Item	DVD Laser Diode		CD Laser Diode	
	Conditions	Characteristic value (TYP.)	Conditions	Characteristic value (TYP.)
Wavelength (Peak)	Po=90mW	661nm	Po=150mW	785nm
Output [Max]	—	90mW [90mW]	—	150mW [160mW]
Threshold current	—	50mA	—	53mA
Operating current	Po=90mW	134mA	Po=150mW	215mA
Operating voltage	Po=90mW	2.4V	Po=150mW	2.4V
Far Field (1/e ²)	Po=90mW	$\theta_{//}$ 8.0-11.5 θ_{\perp} 7.0-10.5	Po=150mW	$\theta_{//}$ 13.5-19.0 θ_{\perp} 13.0-18.0
Terminal connections	No.7			
Package type	t1.8			

CW I-L, I-V Temperature

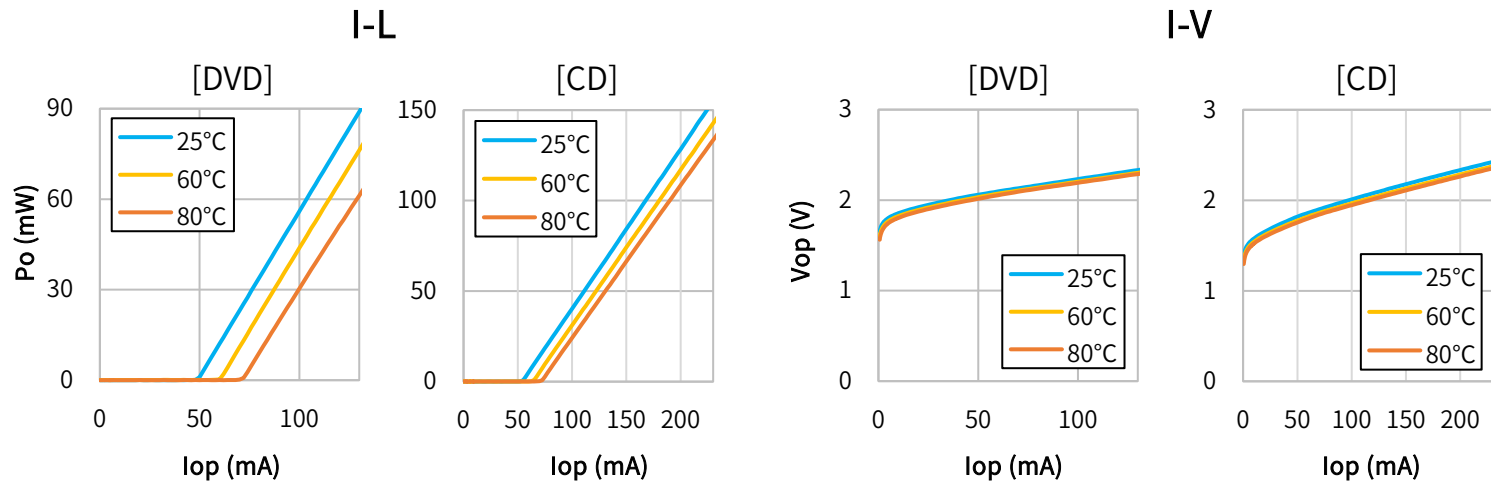

Far Field Pattern

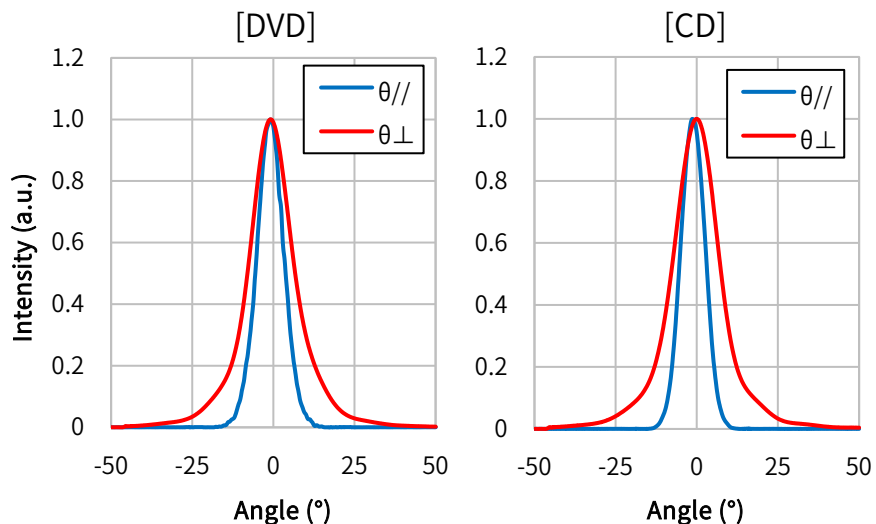

Near Field Pattern

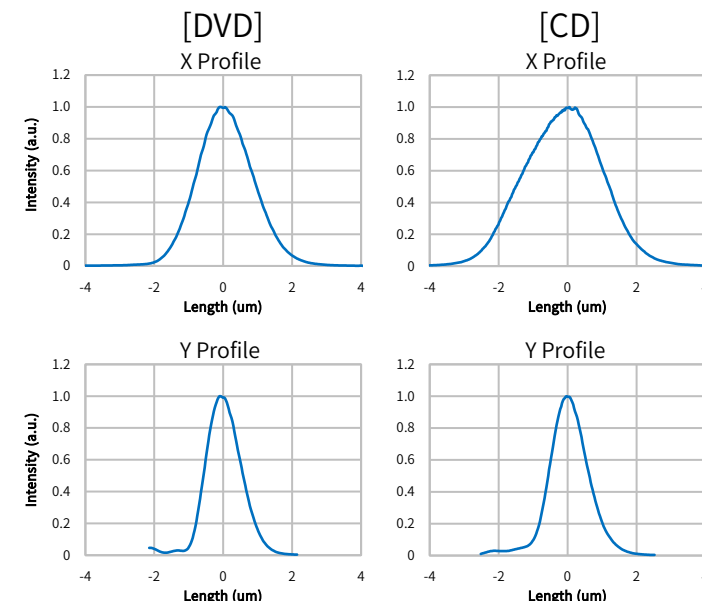
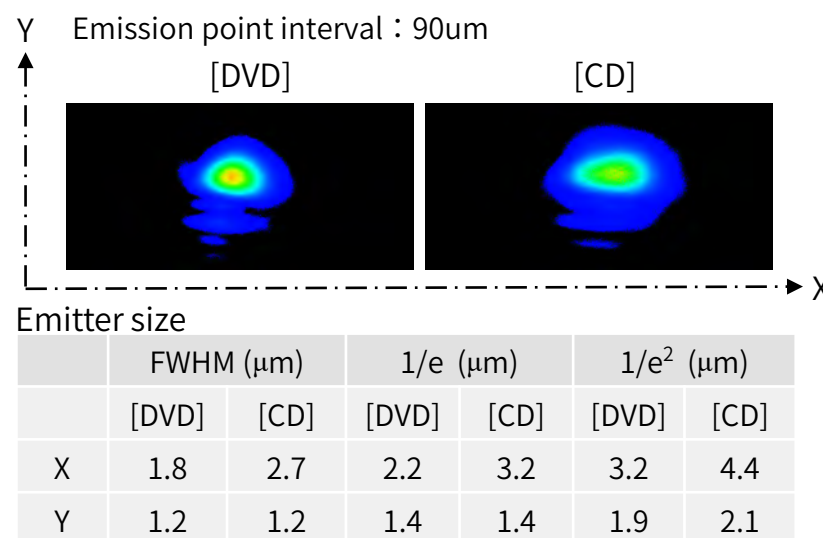



Characteristics

(Tc=25°C, CW)

Item	DVD Laser Diode		CD Laser Diode	
	Conditions	Characteristic value (TYP.)	Conditions	Characteristic value (TYP.)
Wavelength (Peak)	Po=120mW	661nm	Po=150mW	785nm
Output [Max]	—	120mW [125mW]	—	150mW [200mW]
Threshold current	—	68mA	—	55mA
Operating current	Po=120mW	189mA	Po=150mW	230mA
Operating voltage	Po=120mW	2.5V	Po=150mW	2.4V
Far Field (1/e ²)	Po=120mW	$\theta_{//}$ 8.5-11.5 θ_{\perp} 7.0-10.5	Po=150mW	$\theta_{//}$ 14.0-19.0 θ_{\perp} 13.0-18.0
Terminal connections	No.7			
Package type	t1.8			

CW I-L, I-V Temperature

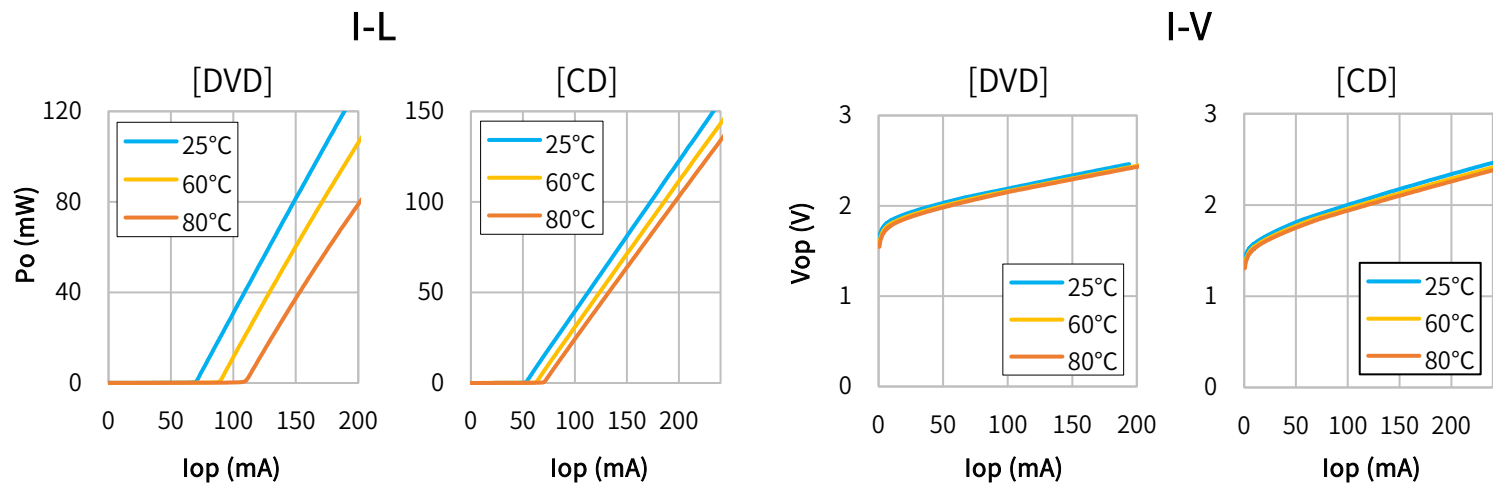

Far Field Pattern

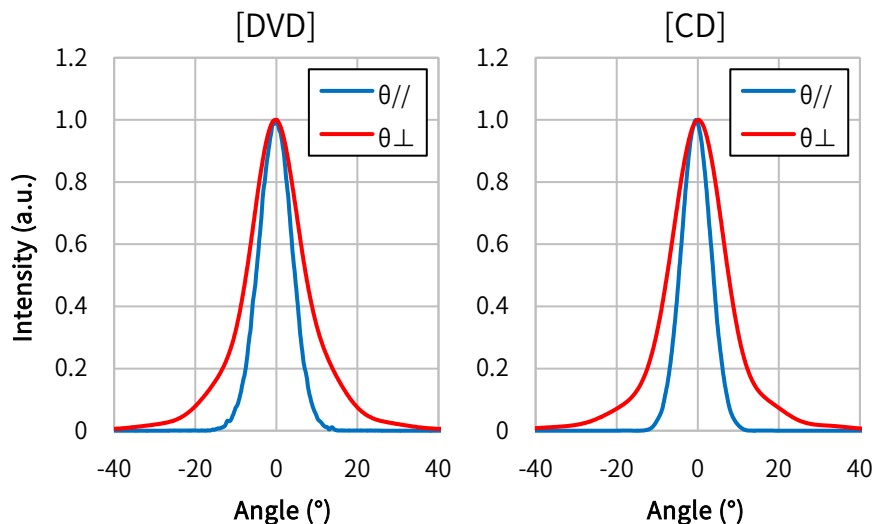

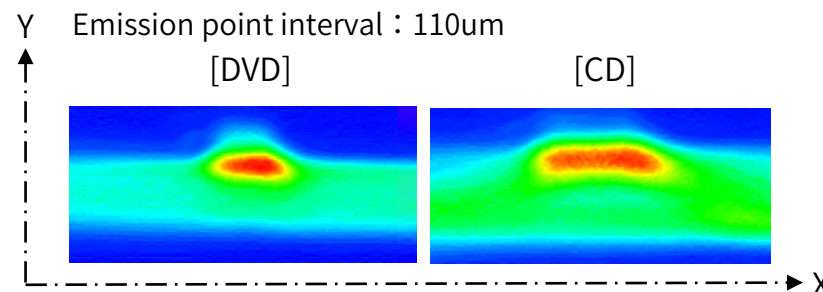

Near Field Pattern

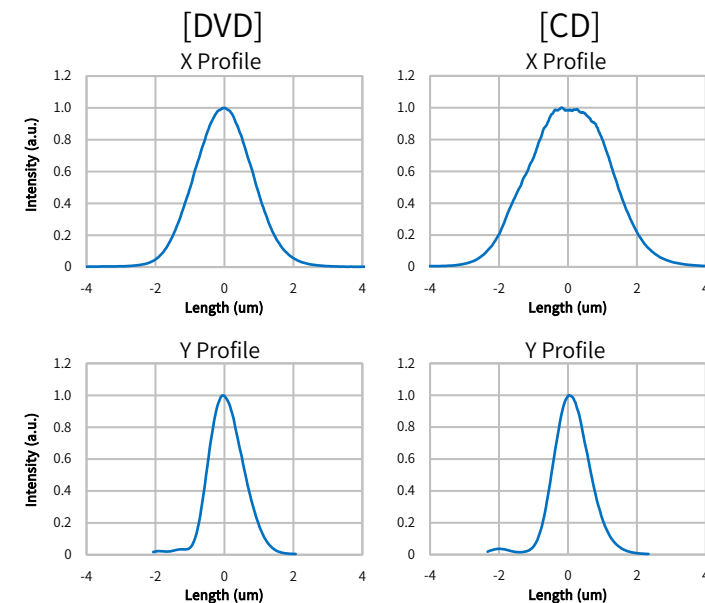

Emitter size

	FWHM (μ m)		1/e (μ m)		1/e ² (μ m)	
	[DVD]	[CD]	[DVD]	[CD]	[DVD]	[CD]
X	2.0	2.9	2.4	3.4	3.4	4.5
Y	1.3	1.2	1.5	1.4	2.1	2.0



Package	$\phi 3.3$ TO-CAN
	

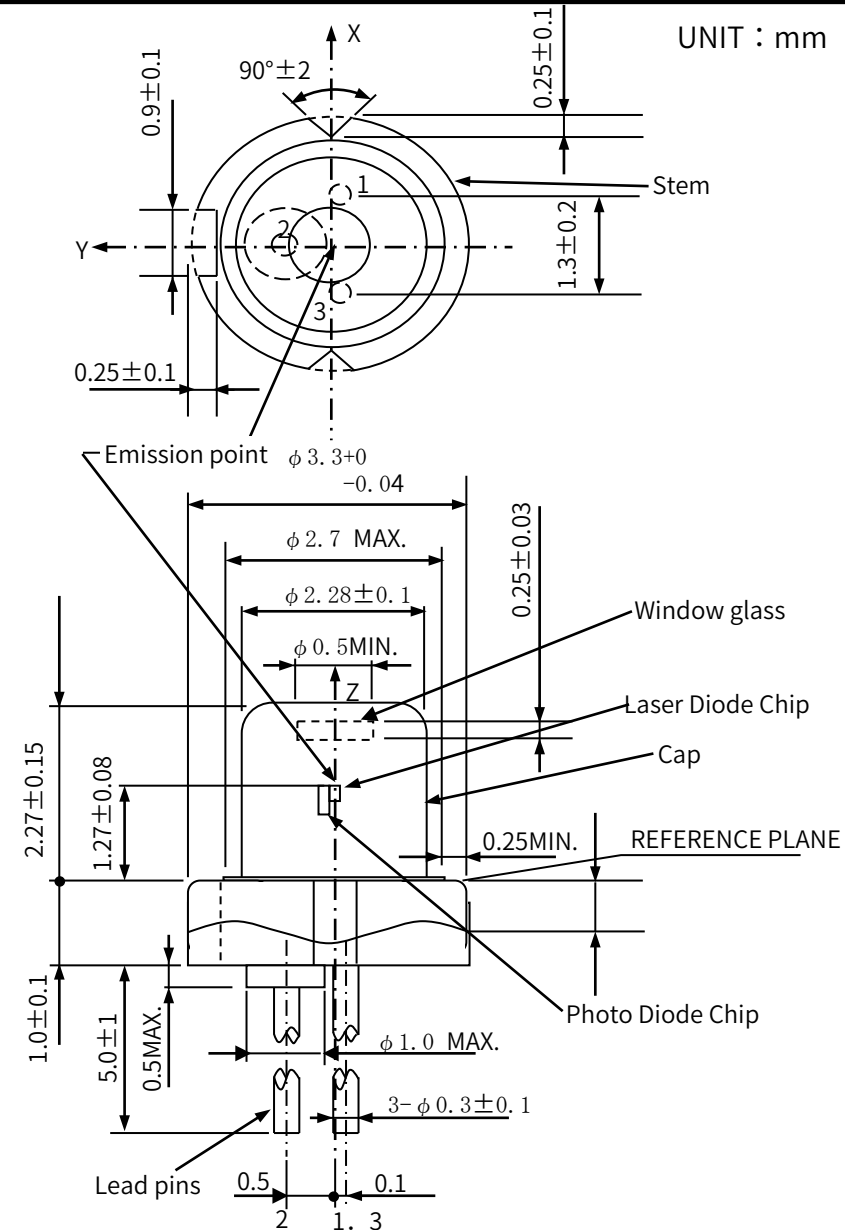
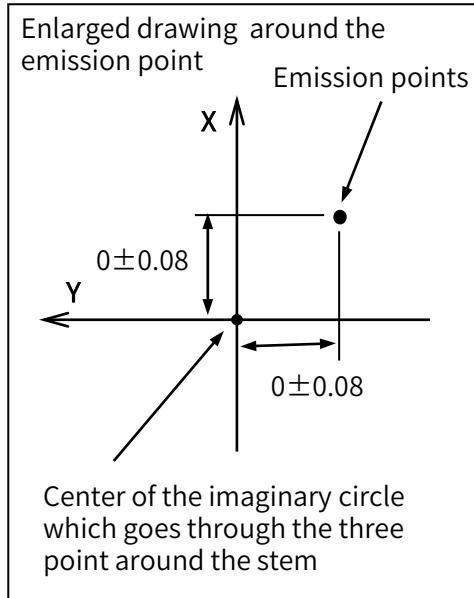

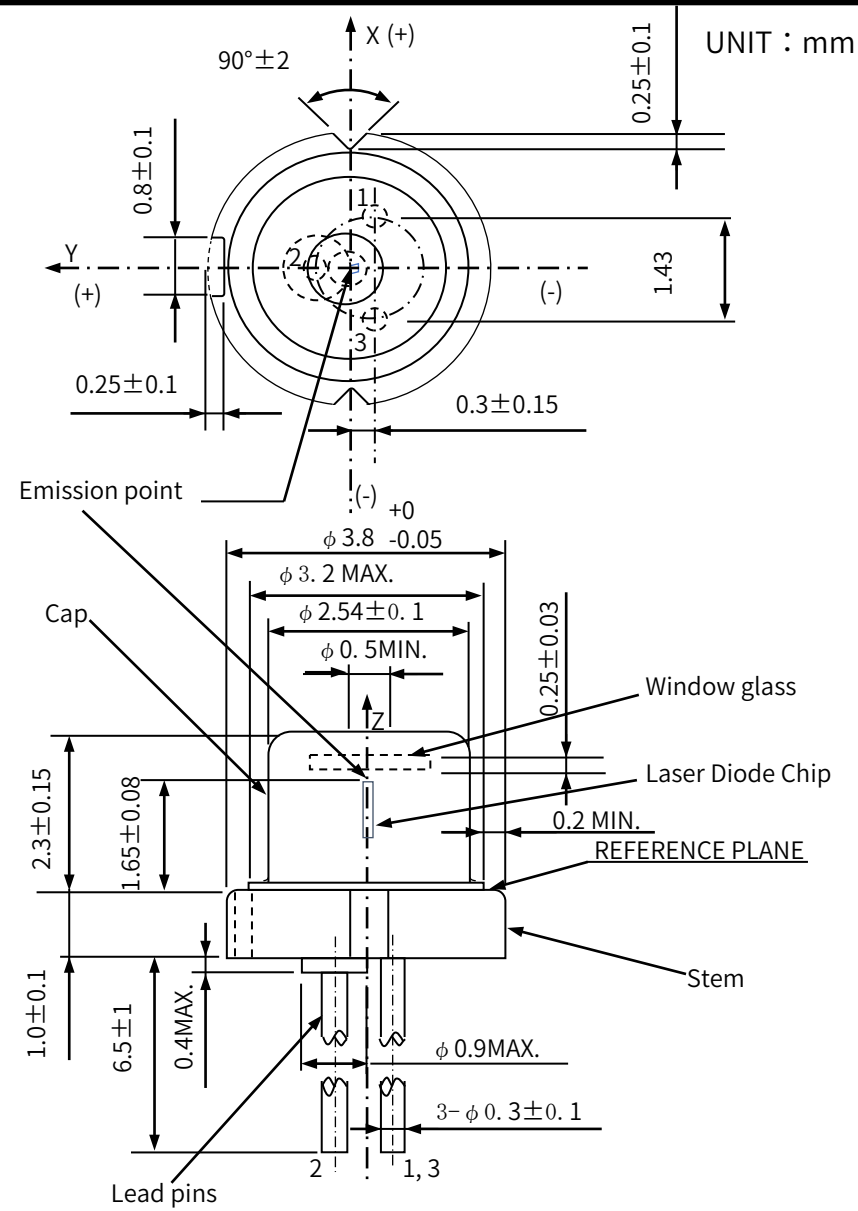
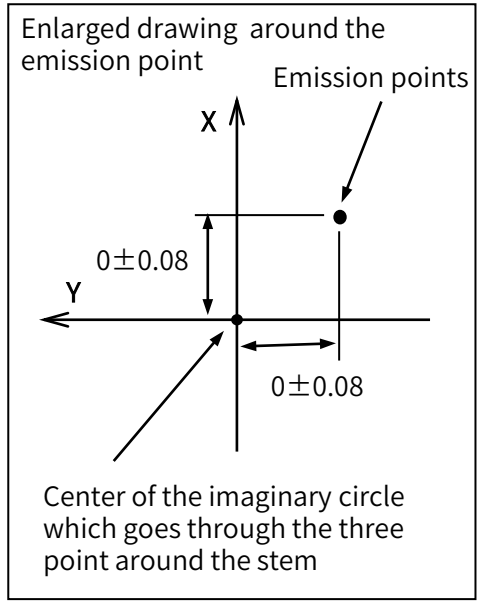

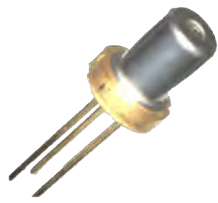
<h2>Package</h2>	<p>$\phi 3.8$ TO-CAN High Cap Model</p>
	

This specification is only applied to GH0631IA5G.

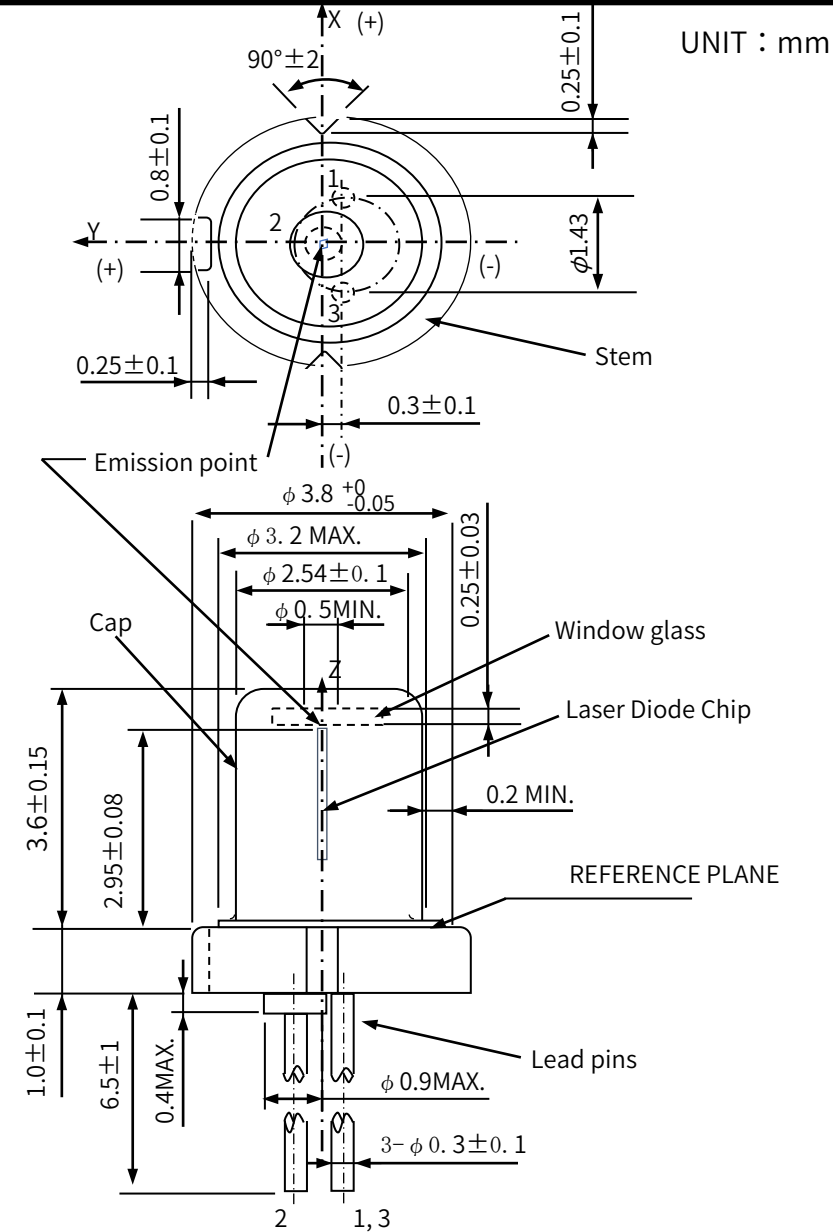
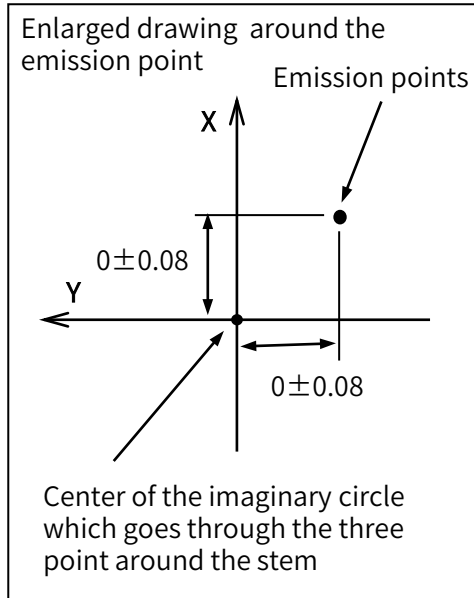

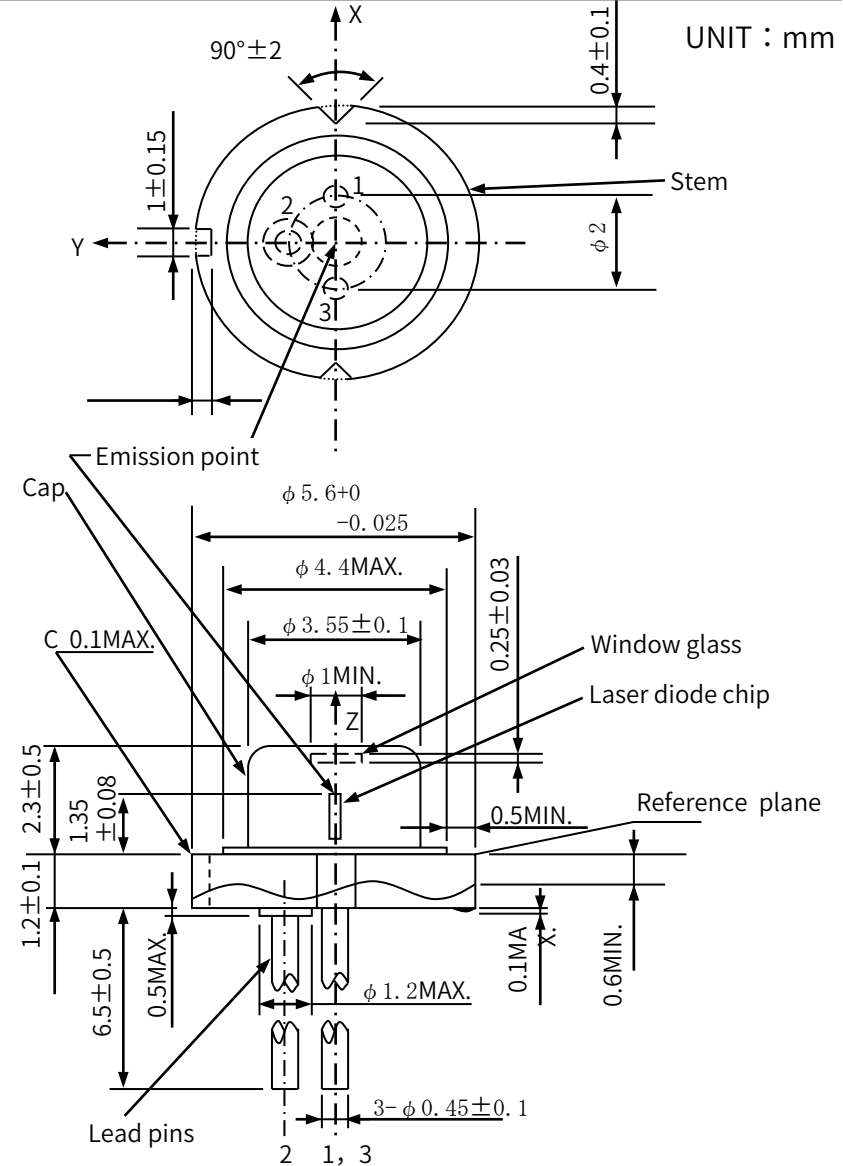
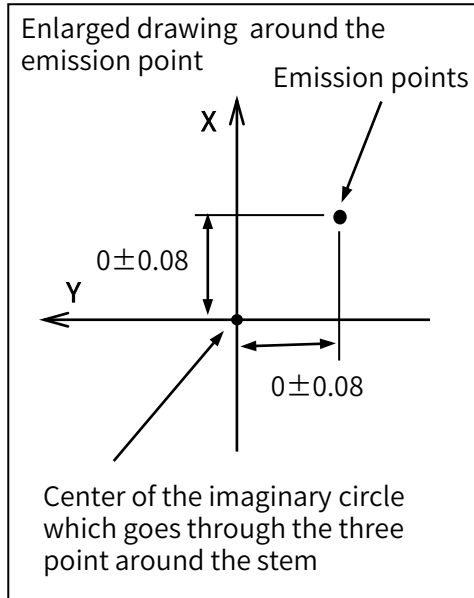
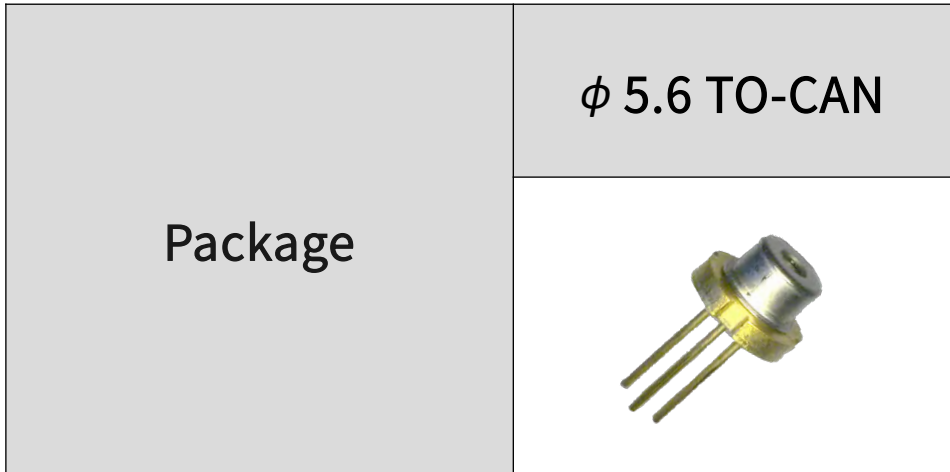

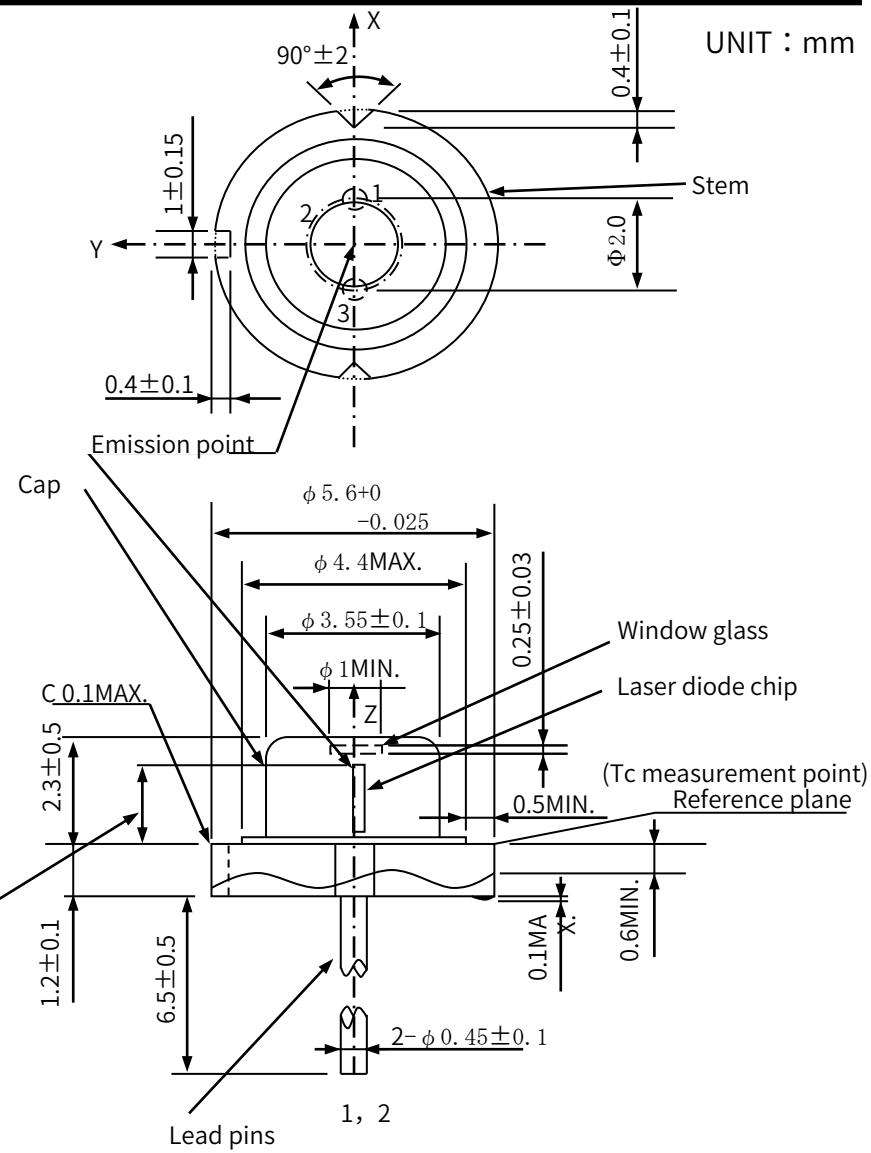
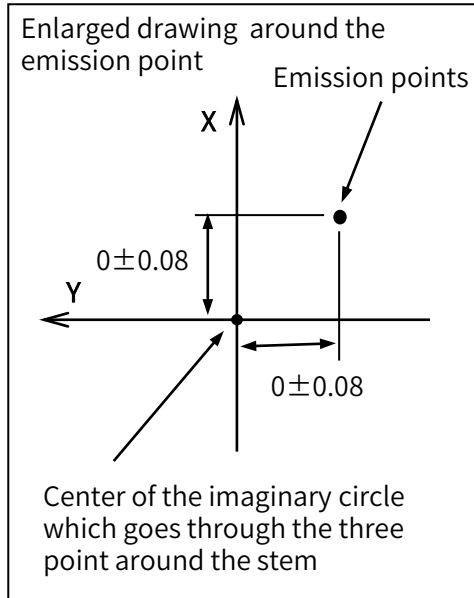
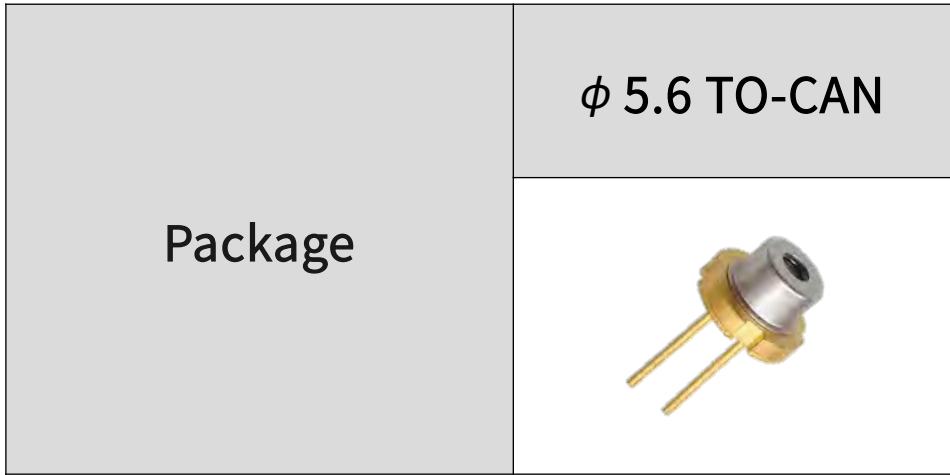

※Table 1 Light emitting point height by model UNIT:mm

Model number		Height of the light emitting point
GH0382AA2G	UV	1.50 ± 0.08
GH0393AA2G	UV	1.35 ± 0.08
GH04W10A2GC	UV	1.35 ± 0.08
GH0406AA2G	UV	1.35 ± 0.08
GH04V01A2GC	UV	1.35 ± 0.08
GH04I01A2G	Blue	1.50 ± 0.08
GH04C01B2G	Blue	1.50 ± 0.08
GH0637AA2G	Red	1.65 ± 0.08

※ Table1

<p>Package</p>	<p>$\phi 5.6$ TO-CAN High Cap Model</p>
	

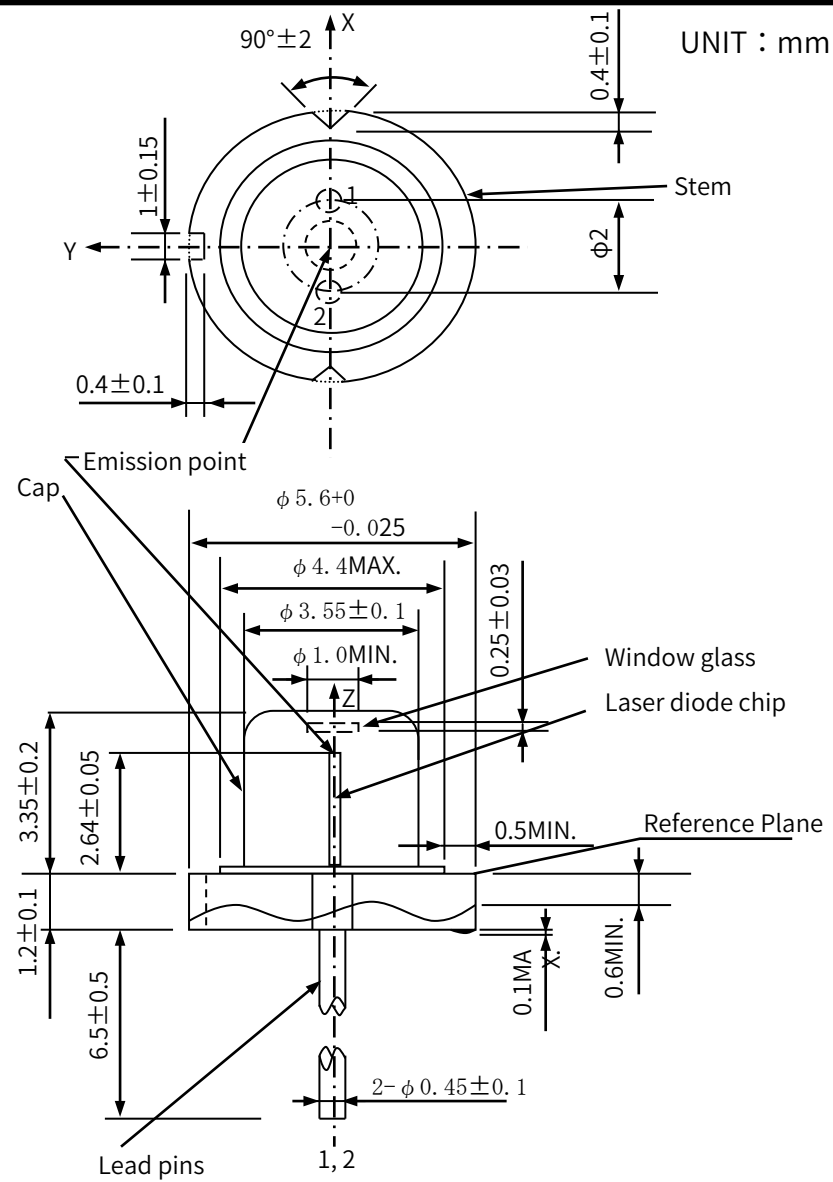
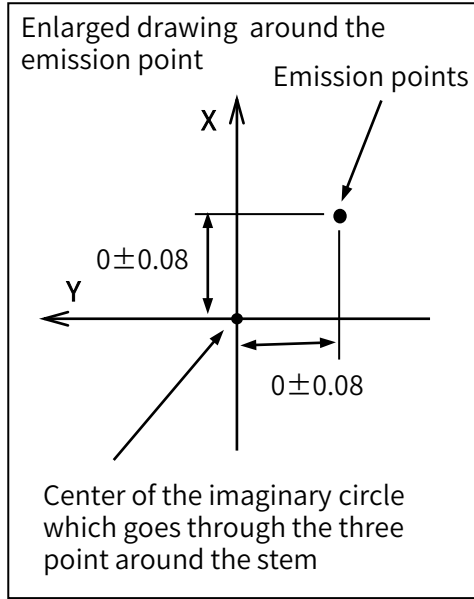

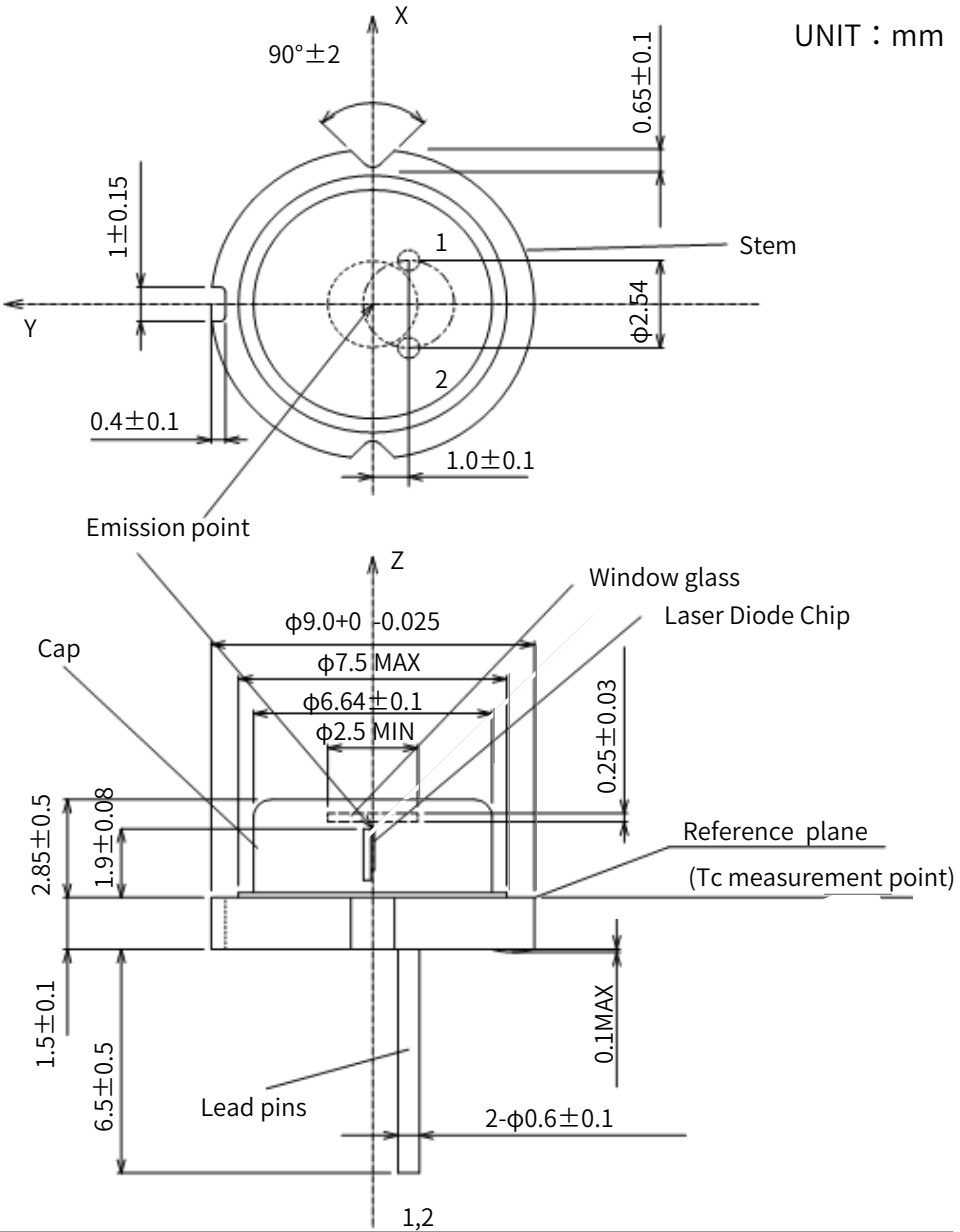
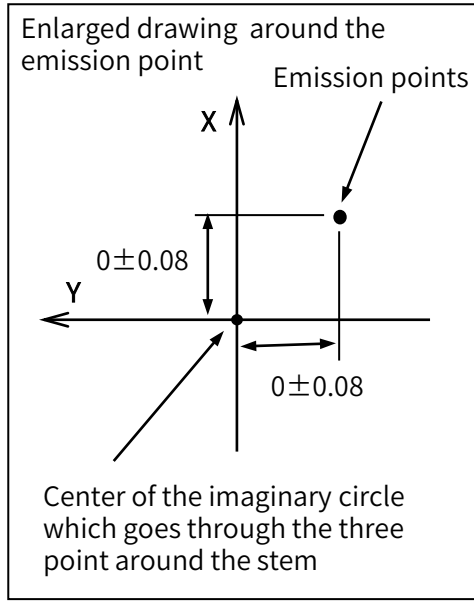
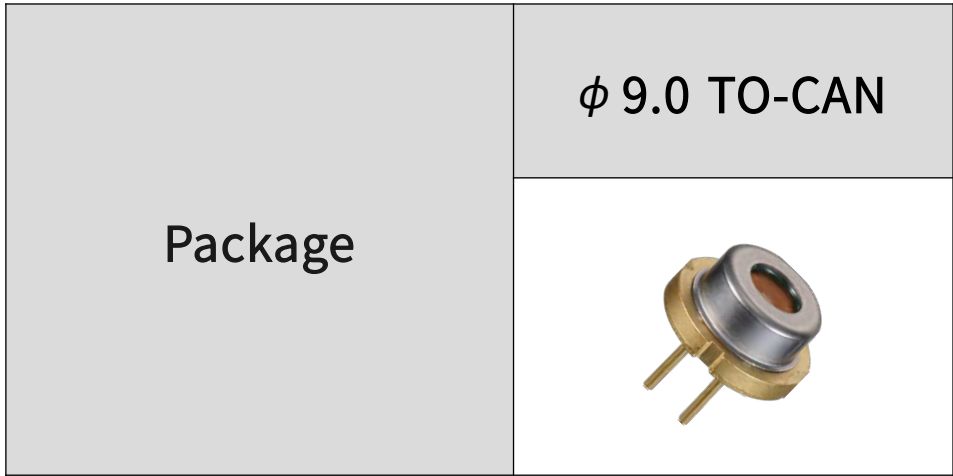

UNIT : mm

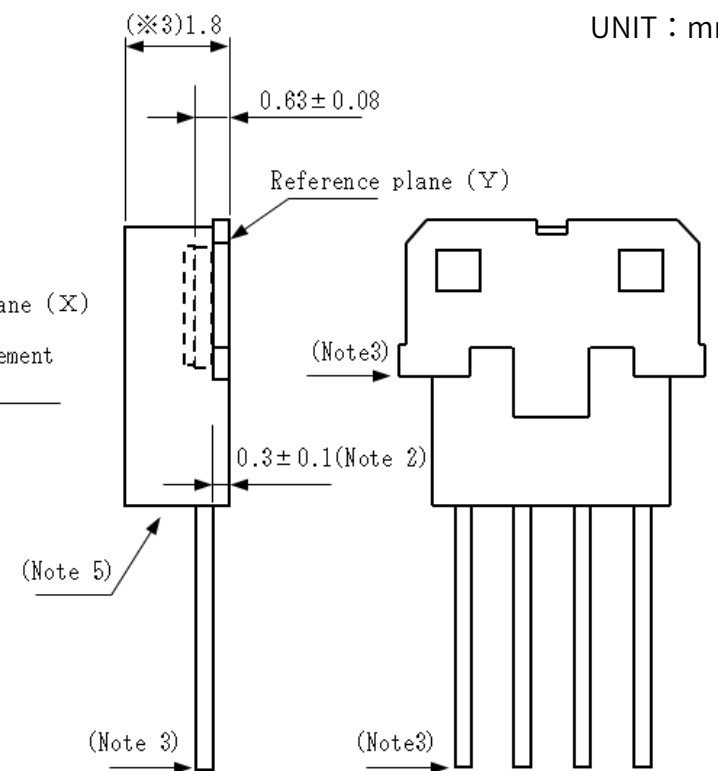
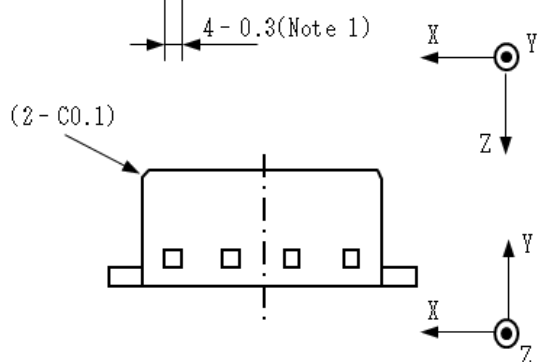
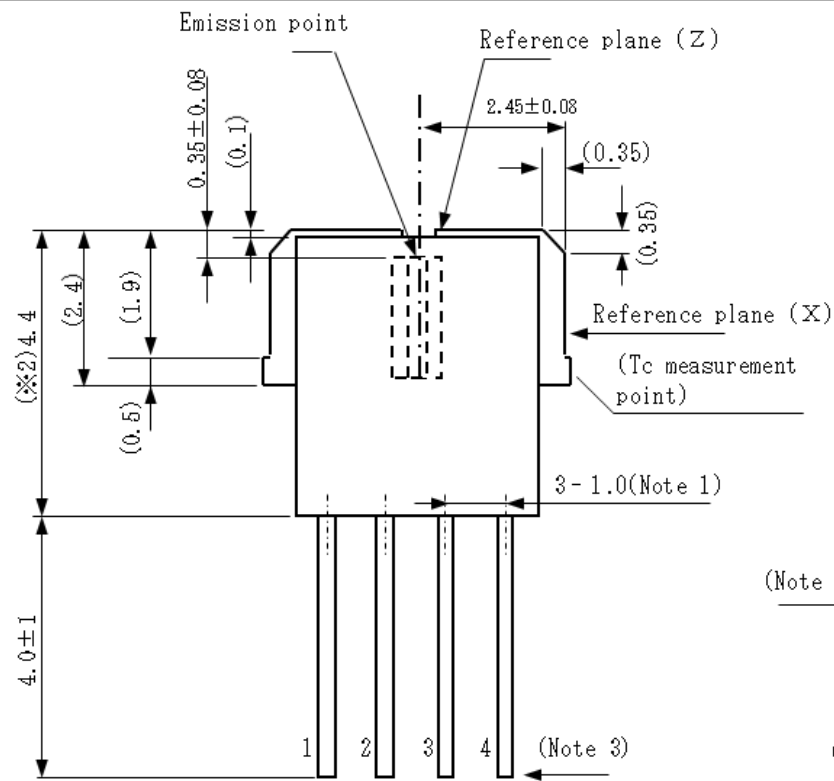
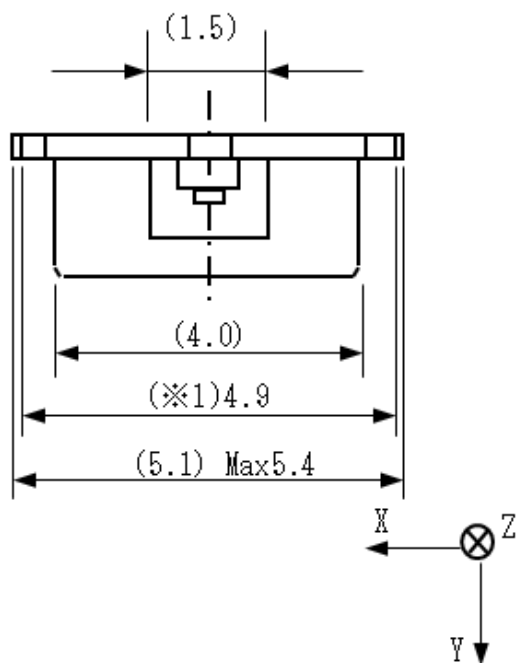
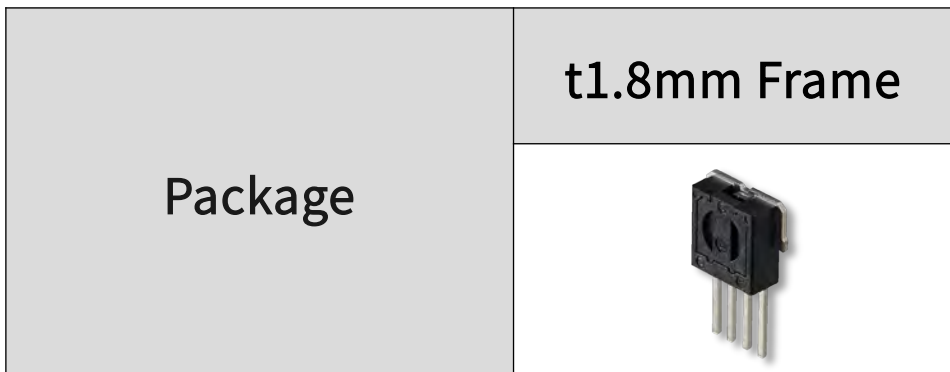

No.1

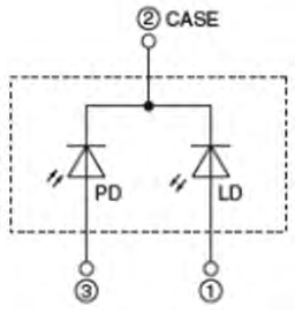

No.2

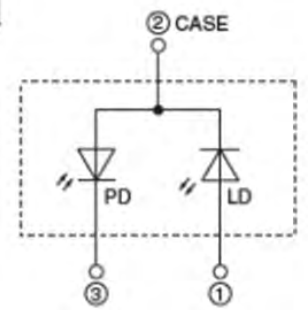

No.3

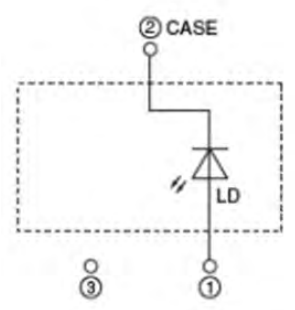

No.4

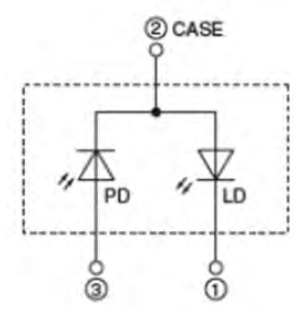

No.5

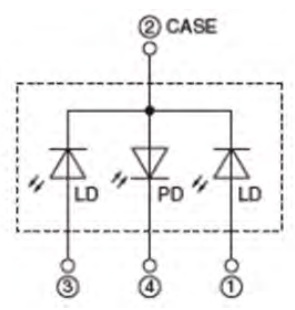

No.6

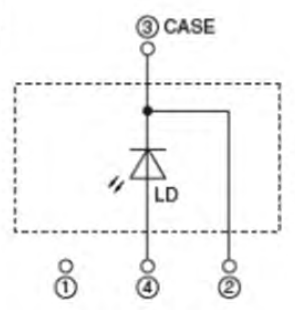

No.7

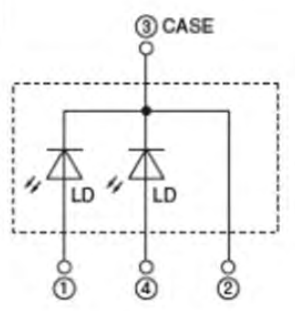

No.8

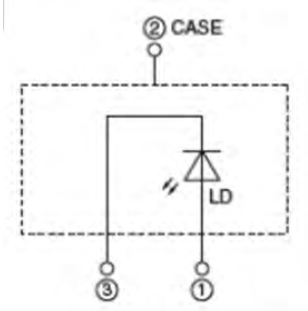

No.9

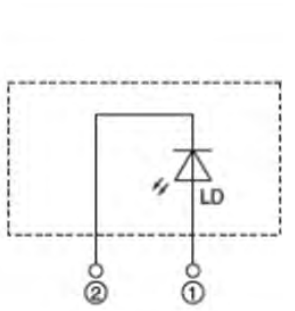

No.10

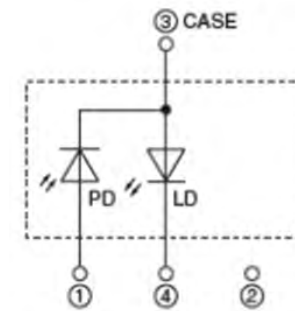

No.11

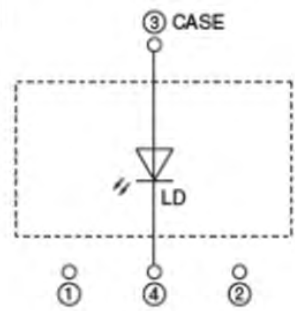

No.12

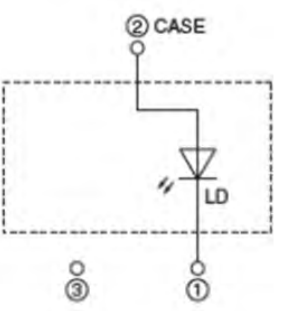

No.13

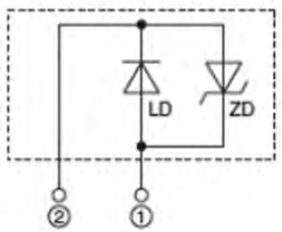

Cautions

1. These specification sheets include materials protected under copyright of Sharp Corporation ("Sharp"). Please handle with great cares and do not reproduce or cause anyone to reproduce them without Sharp's consent.
2. When using this Sharp product, please observe the absolute maximum ratings, other conditions and instructions for use described in the specification sheets, as well as the precautions mentioned below.
Sharp assumes no responsibility for any damages resulting from use of the product which does not comply with absolute maximum ratings, other conditions and instructions for use included in the specification sheets, and the precautions mentioned below.

(Precautions)

- (1) In making catalogue or instruction manual based on the specification sheets, please verify the validity of the catalogue or instruction manuals after assembling Sharp products in customer's products at the responsibility of customer.
- (2) This Sharp product is designed for use in the following application areas ;
 - Computers • OA equipment • Telecommunication equipment (Terminal) • Measuring equipment
 - Tooling machines • Audio visual equipment • Home appliancesIf the use of the Sharp product in the above application areas is for equipment listed in paragraphs (3) or (4), please be sure to observe the precautions given in those respective paragraphs.
- (3) Appropriate measures, such as fail-safe design and redundant design considering the safety design of the overall system and equipment, should be taken to ensure reliability and safety when Sharp product is used for equipment in responsibility of customer which demands high reliability and safety in function and precision, such as ;
 - Transportation control and safety equipment (aircraft, train, automobile etc.)
 - Traffic signals • Gas leakage sensor breakers • Rescue and security equipment • Other safety equipment
- (4) Sharp product is designed for consumer goods and controlled as consumer goods in production and quality.
Please do not use this product for equipment which require extremely high reliability and safety in function and precision, such as ;
 - Space equipment • Telecommunication equipment (for trunk lines) • Nuclear power control equipment • Medical equipment
- (5) Please contact and consult with a Sharp sales representative if there are any question regarding interpretation of the above four paragraphs.

■ Cautions

3. Disclaimer

The warranty period for Sharp product is one (1) year (or six (6) months in case of generalized product) after shipment. During the period, if there are any products problem, Sharp will repair (if applicable), replace or refund. Except the above, both parties will discuss to cope with the problems.

The failed Sharp product after the above one (1) year (or six (6) month for generalized product) period will be coped with by Sharp, provided that both parties shall discuss and determine on sharing responsibility based on the analysis results thereof subject to the above scope of warranty.

The warranty described herein is only for Sharp product itself which are purchased by or delivered to customer. Damages arising from Sharp product malfunction or failure shall be excepted.

Sharp will not be responsible for the Sharp product due to the malfunction or failures thereof which are caused by:

- (1) storage keep trouble during the inventory in the marketing channel.
- (2) intentional act, negligence or wrong/poor handling.
- (3) equipment which Sharp products are connected to or mounted in.
- (4) disassembling, reforming or changing Sharp products.
- (5) installation problem.
- (6) act of God or other disaster (natural disaster, fire, flood, etc.)
- (7) external factors (abnormal voltage, abnormal electromagnetic wave, fire, etc.)
- (8) special environment (factory, coastal areas, hot spring area, etc.)
- (9) phenomenon which cannot be foreseen based on the practical technologies at the time of shipment.
- (10) the factors not included in the product specification sheet.

4. Please contact and consult with a Sharp sales representative for any questions about Sharp product.

U.S.A.

**SHARP ELECTRONICS CORPORATION,
DEVICE DIVISION**
7509 South 5th Street Suite 101 A902
Ridgefield, WA 98642
PHONE: +1-360-834-8700
<https://www.sharpsecd.com/>

EUROPE

SHARP DEVICES EUROPE GMBH
Landshuter Allee 12-14
80637 Munich, Germany
PHONE: +49-89-5468-420 FAX: +49-89-5468-4250
<https://www.sharpsde.com>

ASIA

SHARP SINGAPORE ELECTRONICS CORPORATION PTE., LTD.
Sales & Marketing Group - Device Business
438B Alexandra Road, #06-02, Alexandra Technopark, Singapore 119968
PHONE: +65-6419-3388 FAX: +65-6270-5396 <https://sharpdevices.com>
SECK Corporation
33, Gangnam-Daero 101an-gil, Seocho-Gu, Seoul 06525, Korea
PHONE: +82-2-711-5813 FAX: +82-2-711-5819

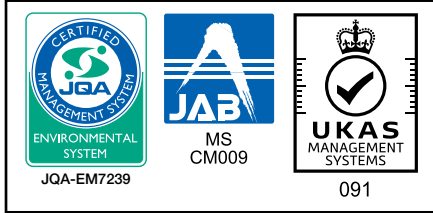

The following related facilities of Sharp Corporation have been certified under the ISO 14001 international standard for environmental management systems. In our products and manufacturing processes, we are actively engaged in environmental preservation efforts.

Facility	Certificate No.	Scope of Registered Activities
Sharp Fukuyama Laser Co., Ltd.	JQA-EM7239	Design/development and production of electronic components and devices

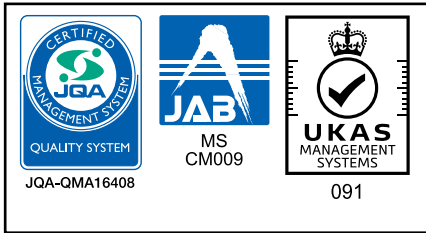

The following groups of Sharp Corporation have been certified under the ISO 9001 international standard for quality management systems.

Certifying organization: Japan Quality Assurance Organization (JQA) [JAB certified]

Group	Certificate No.	Scope of Registered Activities
Sharp Fukuyama Laser Co., Ltd.	JQA-QMA16408	The sales, design/development and manufacturing of the following products. ·Integrated circuits, laser diodes

- Screenshots used are simulated and other images and may differ from the actual screen image.
- The contents of this catalog can also be viewed on our website via the link on the right.
- The product and company names within this catalog are registered trademarks of their respective owners.
- The contents of this catalog are current as of March 31, 2024.

