



TRH160A Series

Application Note V10 November 2019

AC-DC SWITCHING ADAPTER TRH160A Series APPLICATION NOTE



Department	Approved By	Checked By	Written By
Research and Development Department	Enoch	Calvin	Jeter
		Ovid	
Quality Assurance Department	Ryan	Benny	



TRH160A Series

Application Note V10 November 2019

Content

1. INTRODUCTION	3
2. TRH160A SERIES FEATURES	3
3. ELECTRICAL BLOCK DIAGRAM	3
4. TECHNICAL SPECIFICATIONS	4
5. MAIN FEATURES AND FUNCTIONS	7
5.1 Operating Temperature Range	7
5.2 Over Current Protection	7
6. EMC & SAFETY	7
7. APPLICATIONS	7
7.1 Power De-Rating Curve	7
7.2 Test Set-Up	7
7.3 Output Ripple and Noise Measurement	8
8. PART NUMBER	8
9. TRH160A SERIES MECHANICAL OUTLINE DIAGRAMS	9
9.1. Mechanical Outline Diagrams	9
9.2. Packing Information	9



TRH160A Series

Application Note V10 November 2019

1. Introduction

This application note describes the features and functions of Cincon's TRH160A series of adapter, switching AC-DC power. These are highly efficient, reliable, compact, high power density, single output AC/DC power. The power is fully protected against short circuit and over-voltage conditions. Cincon's world class automated manufacturing methods, together with an extensive testing and qualification program ensure that the TRH160A series power is extremely reliable is extremely reliable.

All models are suitable for computer equipment, telecommunications, 5G communication system. Industrial applications and household equipments.

2. TRH160A Series Features

- IEC320/C14 Compact Size
- Universal Input: 90~264Vac
- Over Voltage Protection
- Continuous Short Circuit Protection
- No Load Power Consumption<150mW
- Very Low Leakage Current <90uA
- Meet IEC/EN 60335-1
- Approved IEC/EN/UL62368-1
- CE EN55032 Class B & CISPR/FCC Class B
- Meets CoC Tier 2 & DoE Level VI
(12V: Output Cable Length \leq 950mm)
(24V: Output Cable Length \leq 1220mm)
(28V~48V: Output Cable Length \leq 1800mm)

3. Electrical Block Diagram

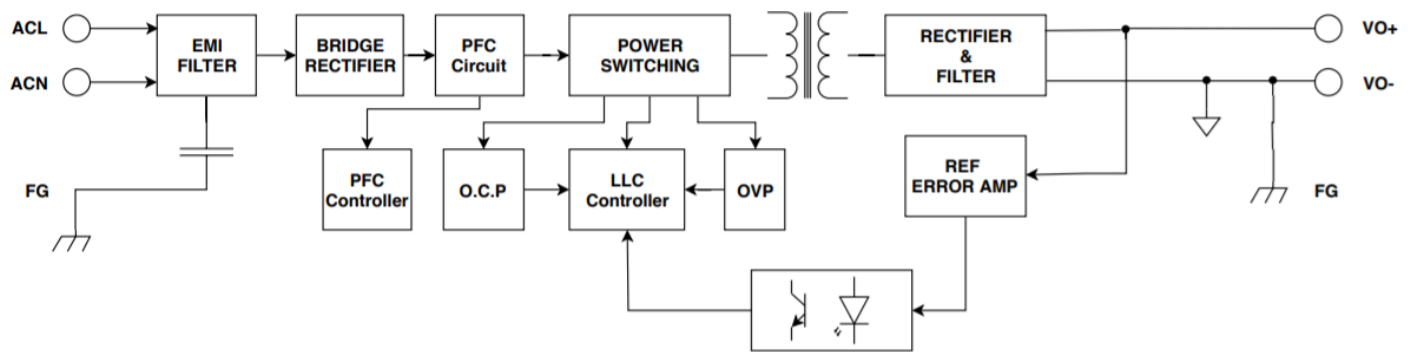



TRH160A Series

Application Note V10 November 2019

4. Technical Specifications

(All specifications are typical at nominal input, full load at 25°C unless otherwise noted.)

ABSOLUTE MAXIMUM RATINGS						
PARAMETER	NOTES and CONDITIONS	Device	Min.	Typical	Max.	Units
Input Voltage		All	90		264	Vac
Operating Temperature	See derating curve (-30°C can be start-up)	All	-20		+70	°C
Storage Temperature		All	-40		+85	°C
Input/Output Isolation Voltage		All			3000	Vac
Altitude		All			5000	m

INPUT CHARACTERISTICS

PARAMETER	NOTES and CONDITIONS	Device	Min.	Typical	Max.	Units
Operating Voltage Range		All	100		240	Vac
Input Frequency Range		All	47		63	Hz
Input Current	100% Load, Vin=100Vac	All			2.0	A
Leakage Current		All			90	uA
Inrush Current	Vin=240Vac, cold start at 25°C	All			120	A

OUTPUT CHARACTERISTICS

PARAMETER	NOTES and CONDITIONS	Device	Min.	Typical	Max.	Units
Output Voltage Set Point	Voltage setpoint at 60% full load. Tc=25°C	TRH160A120	11.76	12	12.24	Vdc
		TRH160A240	23.52	24	24.48	
		TRH160A280	27.44	28	28.56	
		TRH160A300	29.4	30	30.6	
		TRH160A360	35.28	36	36.72	
		TRH160A480	47.04	48	48.96	
		TRH160A560	54.88	56	57.12	
Operating Output Current Range		TRH160A120			12.5	A
		TRH160A240			6.66	
		TRH160A280			5.7	
		TRH160A300			5.31	
		TRH160A360			4.44	
		TRH160A480			3.33	
		TRH160A560			2.85	
Holdup Time	Vin=115Vac	All			25	ms
Output Voltage Regulation						
Load Regulation	from 60% to full load and from 60% to 20% load	TRH160A120			±4%	%
		TRH160A240			±4%	
		TRH160A280			±4%	
		TRH160A300			±4%	
		TRH160A360			±4%	
		TRH160A480			±4%	
		TRH160A560			±4%	
Line Regulation	Vin=high line to low line, full load	All			±1	%



TRH160A Series

Application Note V10 November 2019

PARAMETER	NOTES and CONDITIONS	Device	Min.	Typical	Max.	Units
Output Ripple and Noise	1. Add a 0.1uF ceramic capacitor and a 10uF aluminum electrolytic capacitor to output 2. oscilloscope is 20MHz band width 3. Ambient temperature=25°C	TRH160A120			120	mVp-p
		TRH160A240			240	
		TRH160A280			280	
		TRH160A300			300	
		TRH160A360			360	
		TRH160A480			480	
		TRH160A560			560	
Load Capacitance	1. Ambient temperature=25°C 2. Input voltage is 115VAC and 230VAC 3. Output is max. load	TRH160A120			12250	uF
		TRH160A240			6600	
		TRH160A280			5670	
		TRH160A300			5400	
		TRH160A360			4330	
		TRH160A480			3240	
		TRH160A560			2870	
Efficiency	1. Input voltage is 230VAC 2. Output is max. load.	TRH160A120		91		%
		TRH160A240		92		
		TRH160A280		92		
		TRH160A300		92		
		TRH160A360		92		
		TRH160A480		93		
		TRH160A560		93		

ISOLATION CHARACTERISTICS

PARAMETER	NOTES and CONDITIONS	Device	Min.	Typical	Max.	Units
Input to Output	1 minute	All			3000	Vac
Isolation Resistance		All	100			MΩ

FEATURE CHARACTERISTICS

PARAMETER	NOTES and CONDITIONS	Device	Min.	Typical	Max.	Units
Switching Frequency		All		115		KHz



TRH160A Series

Application Note V10 November 2019

GENERAL SPECIFICATIONS

PARAMETER	NOTES and CONDITIONS	Device	Min.	Typical	Max.	Units
MTBF	Vin=115Vac , Io=100%; Ta=25°C per MIL-HDBK-217F	All	300			K hours
Weight		All		575		g
Safety	Class I, IEC/EN/UL 62368-1					
EMC Emission	EN55032 Class B, FCC Part 15 Class B, EN61000-3-2 EN61000-3-3, EN55024, EN61204-3					
Conducted Disturbance	EN55032:2012 Class B, FCC Part 15 Subpart B Class B					Class B
Radiated Disturbance	EN55032:2012 Class B, FCC Part 15 Subpart B Class B					Class B
Harmonic Current Emissions	IEC 61000-3-2:2014					Class A, Class D
Voltage Fluctuations & Flicker	IEC 61000-3-3:2013					Criteria A
EMC Immunity	IEC 61000-4-2, 3, 4, 5, 6, 8, 11					
Electrostatic Discharge (ESD)	IEC 61000-4-2:2008, ±4kv,±8kv, Criteria A					Criteria A
Radio Frequency Continuous Field	IEC 61000-4-3:2006+A1:2007+A2:2010, Criteria A					Criteria A
Electrical Fast Transient (EFT)	IEC 61000-4-4:2012, ±1kv, Criteria A					Criteria A
Surge	IEC 61000-4-5:2014 L-N:±0.5kv, ±1kv, L-PE, N-PE: ±0.5kv, ±1kv, ±2kv, Criteria A					Criteria A
Conducted Disturbances, Induced by RF Fields	IEC 61000-4-6:2013, Criteria A					Criteria A
Power Frequency Magnetic Field	IEC 61000-4-8:2009, Criteria A					Criteria A
Voltage Dips	IEC 61000-4-11:2004, Dips:30% reduction, Dips: >95% reduction, Criteria A					Criteria A
Voltage Interruptions	IEC 61000-4-11:2004, >95% reduction, Criteria B					Criteria B



TRH160A Series

Application Note V10 November 2019

5. Main Features and Functions

5.1 Operating Temperature Range

The highly efficient design of Cincon's TRH160A series power has resulted in their ability to operate within ambient temperature environments from -20°C to 40°C, -30°C can be start-up at full load. Due consideration must be given to the de-rating curves when ascertaining the maximum power that can be drawn from the power. The maximum power which can be drawn is influenced by a number of factors, such as:

- Input voltage range
- Permissible Output load (per derating curve)
- Effective heat sinks

5.2 Over Current Protection

All different voltage models have a full continuous short-circuit protection. The unit will auto recover once the short circuit is removed. To provide protection in a fault condition, the unit is equipped with internal over-current protection. The unit operates normally once the fault condition is removed. The power module will supply up to 120-140% of rated current. In the event of an over current converter will go into a hiccup mode protection

6. EMC & Safety

- Emission and Immunity
 - EN55032 Class B, FCC Part 15 Class B
 - EN61000-3-2, EN61000-3-3, EN55024, EN61204-3
- Safety
 - Class I, IEC/EN/UL 62368-1

7. Applications

7.1 Power De-Rating Curve

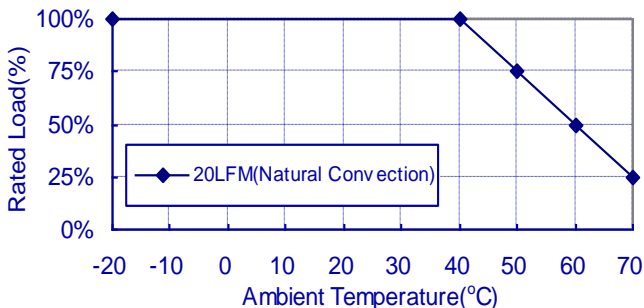

7.2 Test Set-Up

The basic test set-up to measure parameters such as efficiency and load regulation is shown in Figure 1. When testing the Cincon's TRH160A series under any transient conditions, please ensure that the transient response of the source is sufficient to power the equipment under test. We can calculate the

- Efficiency
- Load regulation and line regulation.

The value of efficiency is defined as:

$$\eta = \frac{V_o \times I_o}{P_{in}} \times 100\%$$

Where:

- Vo is output voltage
- Io is output current
- Pin is input power

The value of load regulation is defined as:

$$\text{Load reg.} = \frac{V_{FL} - V_{NL}}{V_{NL}} \times 100\%$$

Where:

- V_{FL} is the output voltage at full load
- V_{NL} is the output voltage at 10% load

The value of line regulation is defined as:

$$\text{Line reg.} = \frac{V_{HL} - V_{LL}}{V_{LL}} \times 100\%$$

Where:

- V_{HL} is the output voltage of maximum input voltage at full load.
- V_{LL} is the output voltage of minimum input voltage at full load.

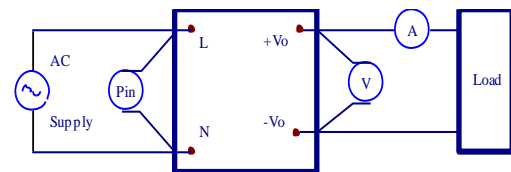

Figure 1 TRH160A Series Test Setup



TRH160A Series

Application Note V10 November 2019

7.3 Output Ripple and Noise Measurement

The test set-up for noise and ripple measurements is shown in Figure 2. Measured method: Add a C1: 10uF electrolytic capacitor and a C2: 0.1uF ceramic capacitor to output at 20 MHz band width.

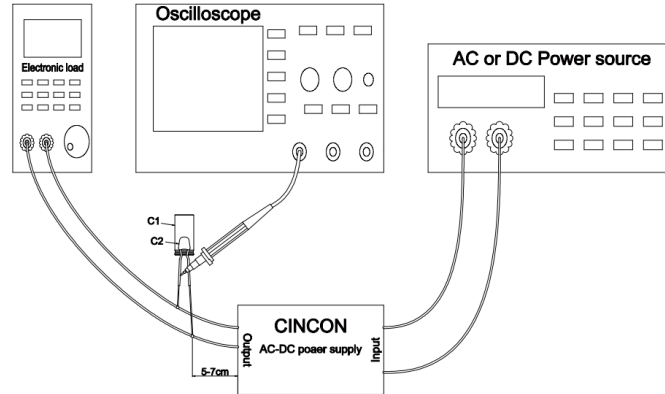
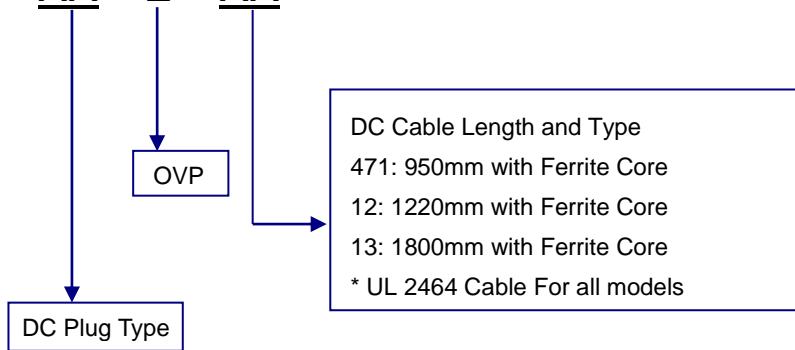

Figure 2 Output Voltage Ripple and Noise Measurement Set-Up

8. Part Number

TRH160A XXX – XX E XX



DC Cable Length and Type
 471: 950mm with Ferrite Core
 12: 1220mm with Ferrite Core
 13: 1800mm with Ferrite Core
 * UL 2464 Cable For all models

120 : Output Voltage 12 VDC
 240 : Output Voltage 24 VDC
 280 : Output Voltage 28 VDC
 300 : Output Voltage 30 VDC
 360 : Output Voltage 36 VDC
 480 : Output Voltage 48 VDC
 560 : Output Voltage 56 VDC:



TRH160A Series

Application Note V10 November 2019

9. TRH160A Series Mechanical Outline Diagrams

9.1. Mechanical Outline Diagrams

All Dimensions are in inches[mm]
 Tolerance:Inches:X.XXX±0.02
 Millimeters:X.XX±0.5
 UNIT:inches[mm]

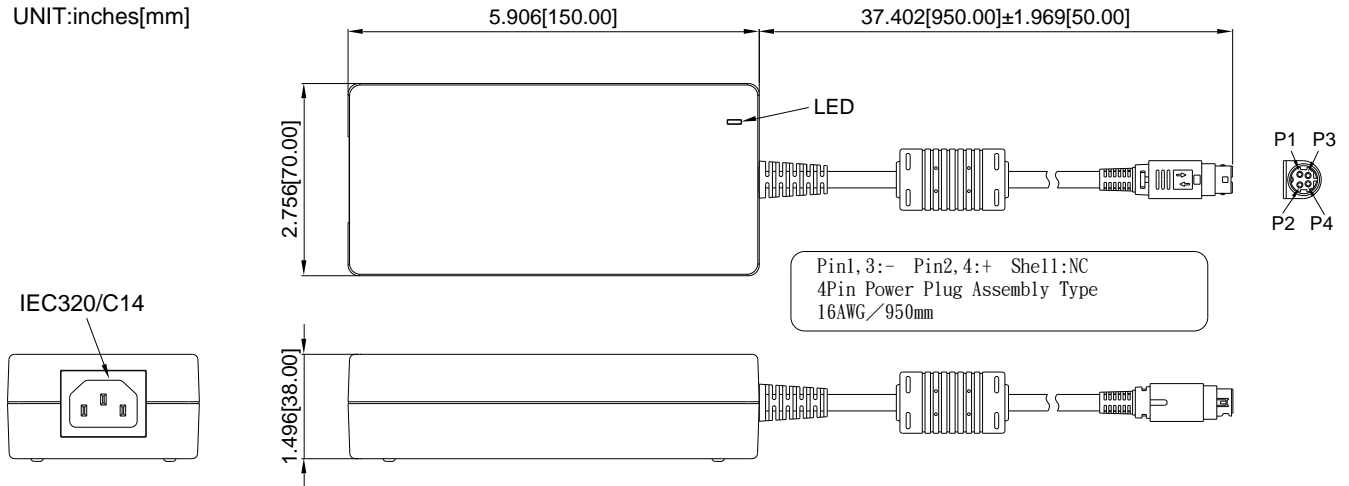

9.2. Packing Information

The packing information for TRH160A series is showing as follows:

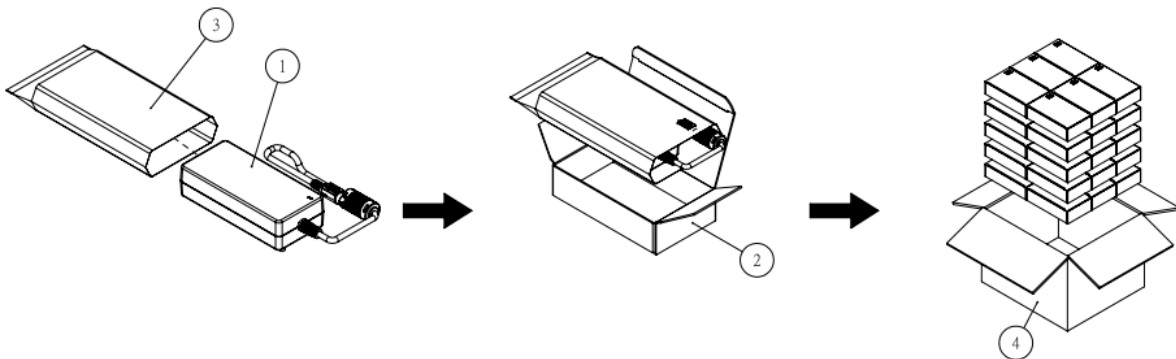

ITEM	PART NO.	NAME	OUTSIDE DIM	PCS
1		TR160XXX Prouduct	150x70x39mm	30
2	G64205321	Inner Box	185x110x50mm	30
3	G64D15057	Plasitc Bag	155x245x0.08mm	30
4	G64114345	NO.163 Cardboard Box	385x345x280mm	1

Each Box Packaging 30 PCS Products
 Net weight Ref. 17.1 Kg
 Gross weight Ref. 18.5 Kg

CINCON ELECTRONICS CO., LTD.

Headquarters:

14F, No.306, Sec.4, Hsin Yi Rd.
 Taipei, Taiwan
 Tel: 886-2-27086210
 Fax: 886-2-27029852
 E-mail:
support@cincon.com.tw
 Web Site:
<http://www.cincon.com>

Factory:

No. 8-1, Fu Kung Rd.
 Fu Hsing Industrial Park
 Fu Hsing Hsiang,
 Chang Hua Hsien, Taiwan
 Tel: 886-4-7690261
 Fax: 886-4-7698031

Cincon North America:

1655 Mesa Verde Ave. Ste 180
 Ventura, CA 93003
 Tel: 805-639-3350
 Fax: 805-639-4101
 E-mail: info@cincon.com