

Stamp C6LoRa

SKU:S012

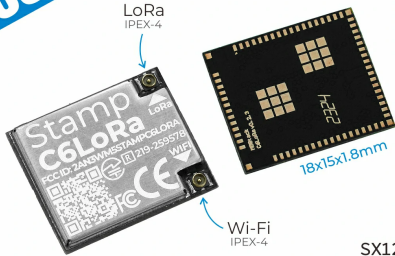

ESP32-C6
16MB Flash

SX1262
2.4GHz Wi-Fi 6
LoRa 850 ~ 960 MHz
LoRa TX: +22dBm / LNA
16 x GPIO + 5 x EXT_IO
POWER INPUT: DC 3.3 ~ 5V

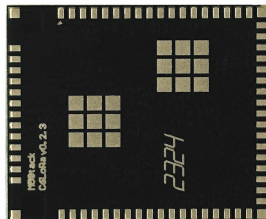
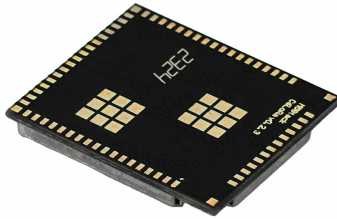
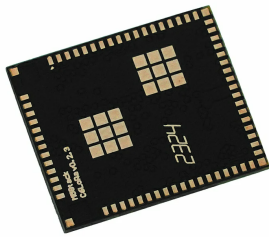



Description

Stamp C6LoRa is a high-performance programmable LoRa module designed for the 850 ~ 960 MHz frequency band. Adopting SMD (Surface Mount Device) technology, it features a compact and small form factor ideal for high-density embedded integration. The core of the module consists of an ESP32-C6 SoC, an SX1262 LoRa RF chip, and an LNA signal amplification chip. Two onboard IPEX-4 antenna connectors are provided for connecting external Wi-Fi and LoRa antennas respectively. The LoRa RF chip delivers a maximum transmit power of +22 dBm and a receive sensitivity of -148 dBm.

The ESP32-C6 main controller integrates abundant peripheral interface resources, supporting secondary development for extended functions. It also supports 2.4 GHz Wi-Fi 6, unlocking more possibilities for IoT applications. A PI4IOE5V6408 IO expansion chip is integrated internally to control the LoRa module's transceiver circuit and signal amplifier enable function, achieving superior power consumption control while providing additional available IO resources. It supports DC 3.3 ~ 5V power input, adapting to various hardware deployment scenarios. It is ideal for long-distance communication applications such as smart irrigation, remote meter reading, and power equipment control.

Features

- ESP32-C6 main controller
- 2.4 GHz Wi-Fi 6
- SX1262 LoRa transceiver
- LoRa operating frequency: 850 ~ 960 MHz
- Built-in Low Noise Amplifier (LNA) to enhance reception performance
- SMD surface-mount package, compact size, and easy integration
- Dual IPEX-4 antenna connectors

Includes

- 1 x Stamp C6LoRa

Applications

- Smart agriculture
- Industrial monitoring
- Outdoor long-range communication

Specifications

Specification	Parameter
SoC	ESP32-C6 (RISC-V 32-bit high-performance single-core processor 160 MHz + RISC-V 32-bit low-power single-core processor 20 MHz)
Flash	16 MB
Wi-Fi	2.4 GHz Wi-Fi 6
LoRa Chip	SX1262
LoRa Frequency	850 ~ 960 MHz
LoRa Transmit Power	Max Transmit Power: +22 dBm / Max Sensitivity: -148 dBm
Antenna Connector	IPEX-4
LNA	SGM13005L4
GPIO Leads	16x GPIO (G9/G11/G8/G10/G2/G7/G4/G5/G6/G15/G16/G17/G18/G20/G21/G22) + 5x EXT_IO Expansion (PI4IOE5V6408: EXT_P0 ~ P4)
Operating Power	Supports DC 3.7 ~ 5V input via the BAT pin / DC 3.3V input via the VDD_3V3 pin
Product Size (SMD)	18.0 x 15.0 x 2.3 mm
Product Weight	1.7 g
Package Size	138.0 x 93.0 x 7.0 mm
Gross Weight	4.5 g

Learn

Firmware Burning

Stamp C6LoRa supports program downloading via UART or USB interface. Before downloading, hold the Boot pin (GPIO9) low and reset the module to enter download mode.

- For UART downloading, an USB-TTL adapter is required. The wiring diagram below uses the [ESP32 Downloader](#) as an example for connecting to the UART download interface of Stamp C6LoRa.
- The ESP32 Downloader includes an automatic download circuit that automatically triggers download mode when flashing.

- For USB downloading, hold the Boot pin low and reset the module via the RST pin (low level → high level) to enter download mode.

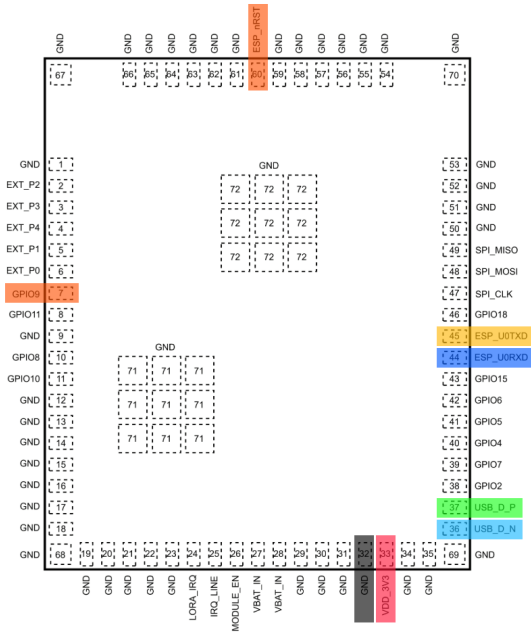

UART Download

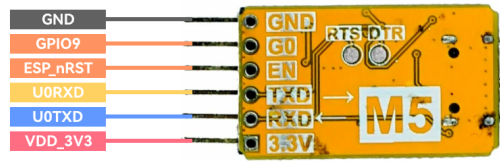

USB Download

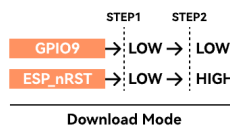
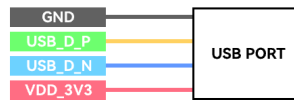

Boot Mode	GPIO8	GPIO9
SPI boot mode	Any value	1
Joint download boot mode²	1	0

¹ Bold marks the default value and configuration.

² Joint Download Boot mode supports the following download methods:

- USB-Serial-JTAG Download Boot
- UART Download Boot
- SDIO Download Boot

Antenna Installation

Stamp C6LoRa uses IPEX-4 antenna connectors. The locations of the LoRa and Wi-Fi antenna interfaces are shown in the figure below.

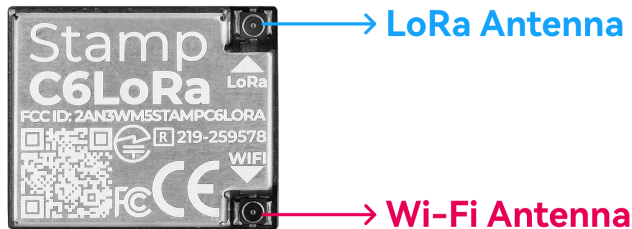

Module Power Supply

The BAT pin of Stamp C6LoRa supports DC 3.7 ~ 5V power input. **Only when powering via the BAT pin must the MODULE_EN pin be pulled high to enable power supply**; no operation on the MODULE_EN pin is required when supplying DC 3.3V via the VDD_3V3 pin.

Schematics

- Stamp C6LoRa Schematics PDF

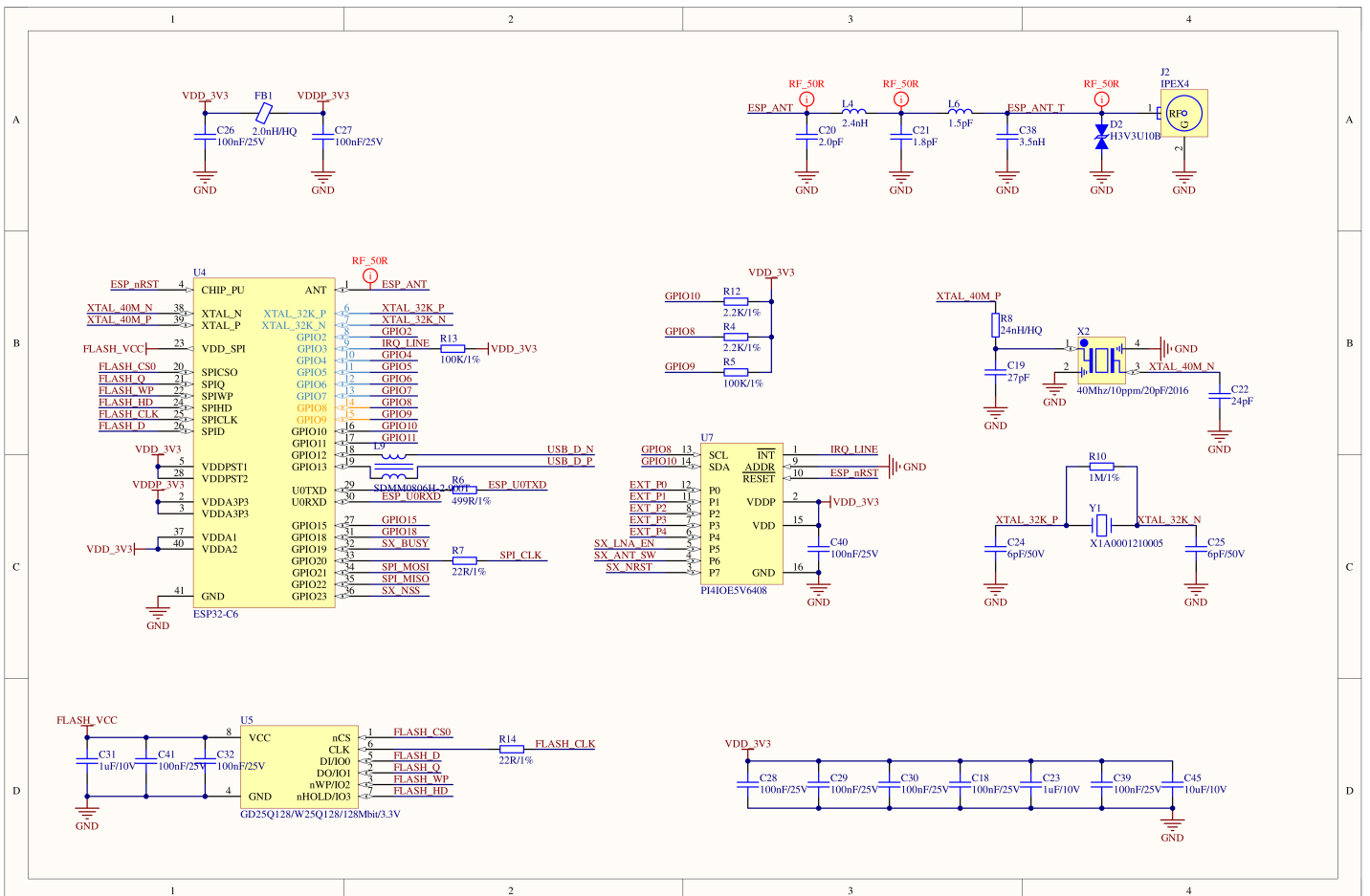
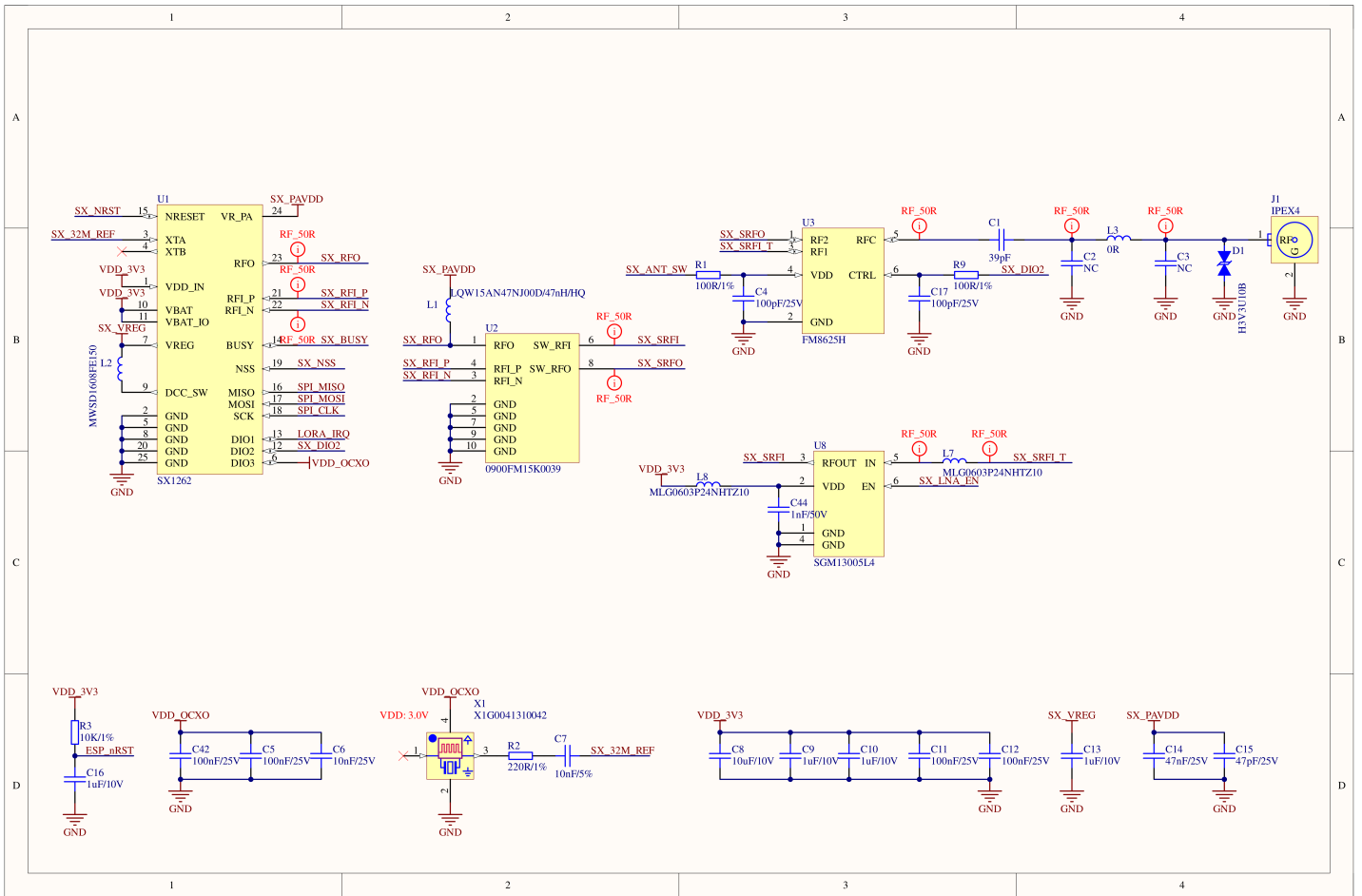

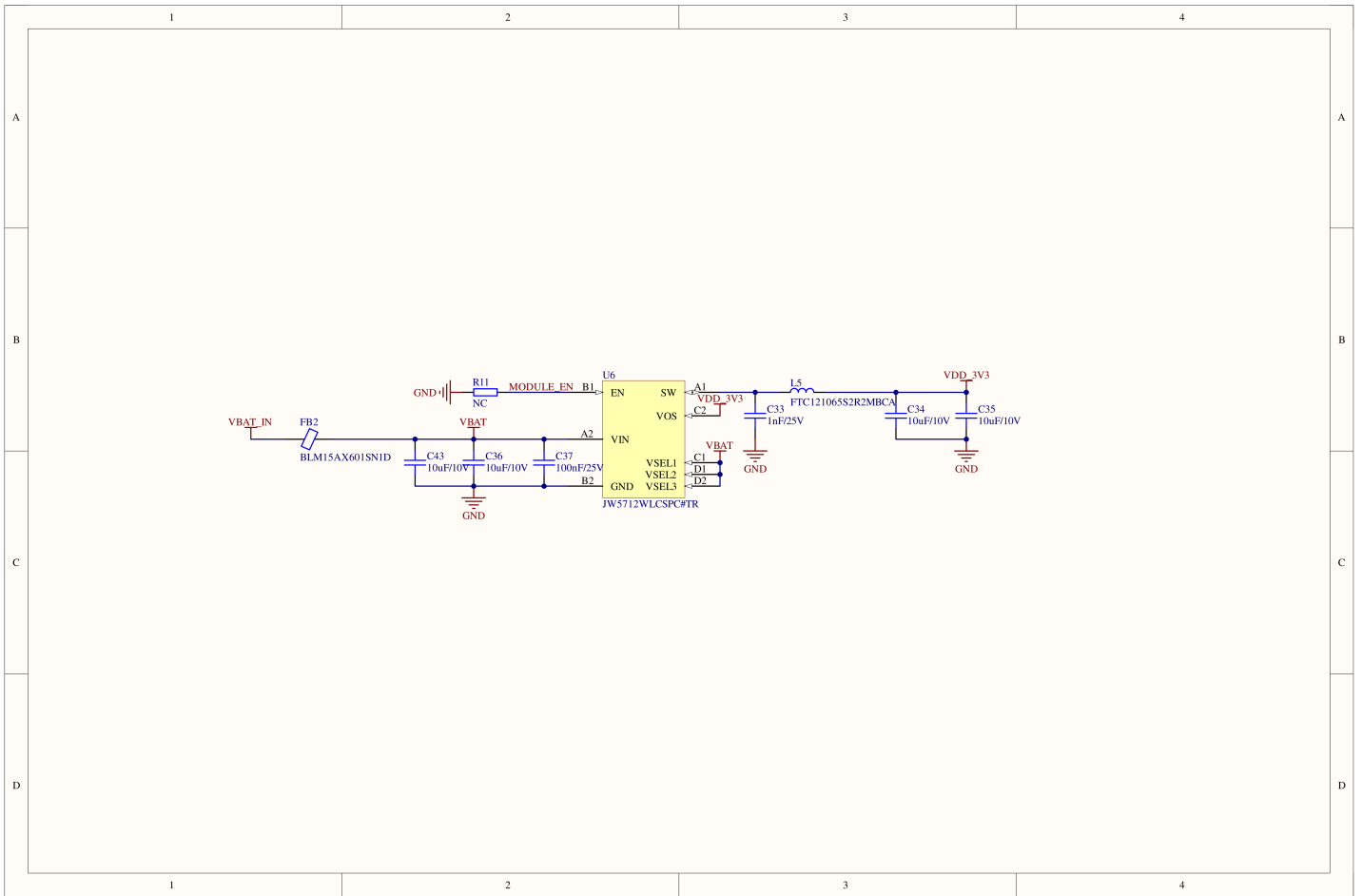

PinMap

Pinout Diagram

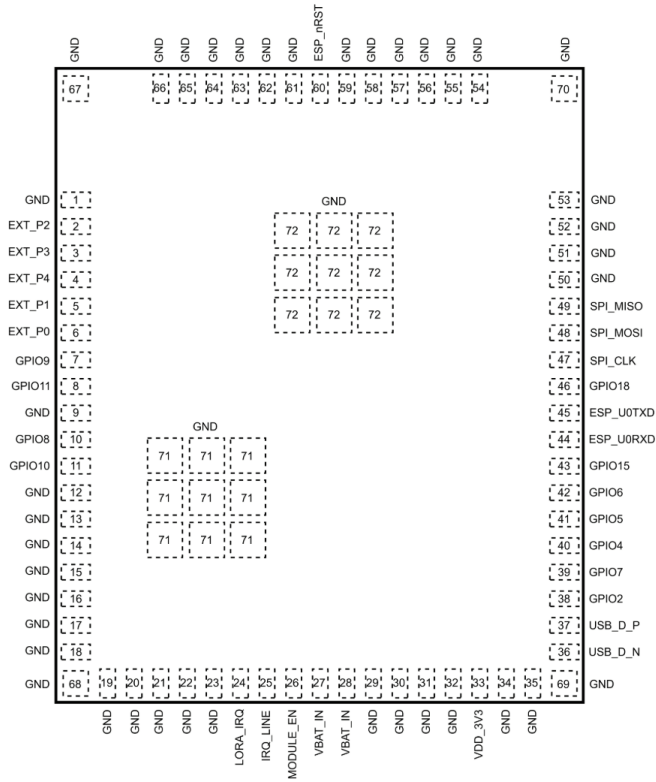

Stamp C6LoRa

ESP32-C6	G21	G22	G20	G23	G19	G7
SX1262	MOSI	MISO	SCK	CS	BUSY	IRQ

ESP32-C6	G8	G10	G3	ESP_RST
PI4IOE5V6408	SCL	SDA	INT	RST

PI4IOE5V6408	E0.P5	E0.P6	E0.P7
SX1262	SX_LNA_EN	SX_ANT_SW	SX_NRST

The following steps are required for LoRa module initialization:

- Reset the LoRa module: Set SX_NRST low, hold for 100 ms, then set high.
- Enable the RF antenna switch: Set SX_ANT_SW high.
- Enable the LNA chip: Set SX_LNA_EN high.

Model Size

- [Stamp C6LoRa Model Size PDF](#)

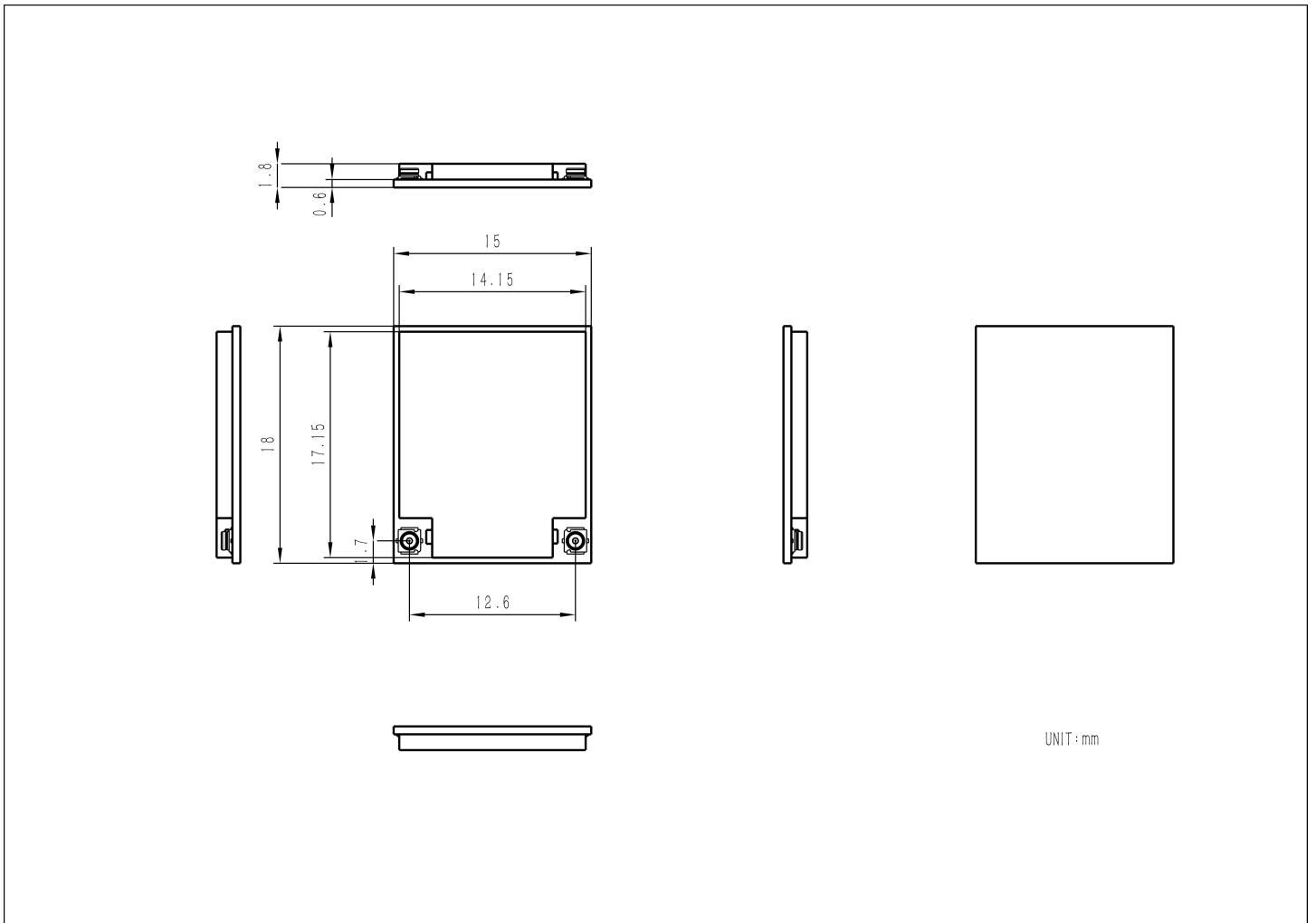

PCB

- [Stamp C6LoRa PcbDoc](#)
- [Stamp C6LoRa KiCad Footprint Library](#)

3D

- [Stamp C6LoRa Structure Files](#)

Softwares

Arduino

- [Stamp C6LoRa Arduino Quick Start](#)

PlatformIO

```
[env:m5stack-stamp-c6lora]
platform = https://github.com/pioarduino/platform-esp8266.git#55.03.37
board = esp32-c6-devkitc-1
framework = arduino
upload_speed = 1500000
monitor_speed = 115200
build_flags =
  -D ARDUINO_USB_MODE=1
  -D ARDUINO_USB_CDC_ON_BOOT=0
  ; -DCORE_DEBUG_LEVEL=5
lib_deps =
  M5Unified=https://github.com/m5stack/M5Unified
  RadioLib=https://github.com/jgromes/RadioLib
```

| Video

- Stamp C6LoRa Product Introduction and Functional Demonstration

[S012-Stamp-C6LoRa-intro-video_EN.mp4](#)