

# Hardware Development Guide for the MIMXRT1050/MIMXRT1060 Processor

## 1. Introduction

This document's purpose is to help hardware engineers design and test their MIMXRT1050/MIMXRT1060 processor-based designs. It provides information about board layout recommendations and design checklists to ensure first-pass success and avoidance of board bring-up problems. At the same time, as MIMXRT1060 is pin-to-pin compatible with MIMXRT1050, thus IMXRT1050-EVKB shared the same design with MIMXRT1060-EVK, and all the following hardware design guide for MIMXRT1050 is applicable to MIMXRT1060 too. At the same time, MIMXRT1064 is just the SIP version of RT1060, so RT1064 can also reuse this hardware design guide. This guide is released along with the relevant device-specific hardware documentation such as data sheets, reference manuals, and application notes available on [nxp.com](http://nxp.com).

## Contents

1.	Introduction.....	1
2.	Background.....	2
3.	Power supply.....	2
4.	Clocks .....	7
5.	Debugging and programming .....	9
6.	Boot, reset, and miscellaneous .....	11
7.	Layout recommendations .....	16
7.1.	Stackup .....	16
7.2.	Placement of bulk and decoupling capacitors .....	17
7.3.	FlexSPI .....	17
7.4.	SDRAM .....	18
7.5.	USB .....	18
7.6.	High-speed signal routing recommendations .....	19
8.	Revision history .....	20



## 2. Background

The MIMXRT1050/MIMXRT1060 processors are NXP's latest additions to a growing family of real-time processing products, offering high-performance processing optimized for lowest power consumption and best real-time response. The MIMXRT1050/MIMXRT1060 processors feature NXP's advanced implementation of the Arm<sup>®</sup> Cortex<sup>®</sup>-M7 core which operates at speeds of up to 600 MHz. The MIMXRT1050/MIMXRT1060 processors are specifically useful for applications such as:

- Industrial Human Machine Interfaces (HMI)
- Motor control
- Home appliances

## 3. Power supply

See [Table 1](#) and [Table 2](#) for the power domains and power supply decoupling recommendations. Note that the power control diagram is applicable to MIMXRT1050 A1 and MIMXRT1060 silicon.

**Table 1. Power domains**

Power rail	MIN (V)	TYP (V)	MAX (V)	Description
VDD_SOC_IN	0.925	—	1.3 <sup>1</sup>	Power for the core supply
VDD_HIGH_IN	2.8	3.3	3.6	VDD_HIGH_IN supply voltage
DCDC_IN	3.0	3.3	3.6	Power for the DCDC
VDD_SNVS_IN	2.4	3	3.6	Power for the SNVS and RTC
USB_OTG1_VBUS USB_OTG2_VBUS	4.4	5	5.5	Power for the USB VBUS
VDDA_ADC_3P3	3	3.3	3.6	Power for the 12-bit ADC
NVCC_SD0	3	3.3	3.6	Power for the GPIO in the SDIO1 bank (3.3 V mode)
	1.65	1.8	1.95	Power for the GPIO in the SDIO1 bank (1.8 V mode)
NVCC_SD1	3	3.3	3.6	Power for the GPIO in the SDIO2 bank (3.3 V mode)
	1.65	1.8	1.95	Power for the GPIO in the SDIO2 bank (1.8 V mode)
NVCC_EMCC	3	3.3	3.6	IO supply for the GPIO in the EMC bank (3.3 V mode)
	1.65	1.8	1.95	IO supply for the GPIO in the EMC bank (1.8 V mode)
NVCC_GPIO	3	3.3	3.6	IO power for the GPIO

1. Maximum voltage is 1.26 V for the industrial part numbers.

**Table 2. Power supply decoupling recommendations**

Power rail	Decoupling and bulk capacitors (min qty)	Description
VDD_SOC_IN	$5 \times 0.22 \mu\text{F}^2 + 1 \times 4.7 \mu\text{F}^1 + 1 \times 22 \mu\text{F}^3$	Place at least one 4.7 $\mu\text{F}$ capacitor and three 0.22 $\mu\text{F}$ capacitors next to balls F6, F7, F8, and so on.
VDD_HIGH_IN	$1 \times 0.22 \mu\text{F}^2 + 1 \times 4.7 \mu\text{F}^1$	—
VDD_HIGH_CAP	$1 \times 0.22 \mu\text{F}^2 + 1 \times 4.7 \mu\text{F}^1$	VDD_HIGH_CAP is restricted to the RT1050/RT1060 loads.
DCDC_IN	$3 \times 0.22 \mu\text{F}^2 + 1 \times 4.7 \mu\text{F}^1 + 1 \times 22 \mu\text{F}^3$	Place at least one 4.7 $\mu\text{F}$ capacitor and one 0.22 $\mu\text{F}$ capacitor next to ball L1, L2 and K4.
VDD_SNVS_IN	$1 \times 0.22 \mu\text{F}^2$	—
VDD_SNVS_CAP	$1 \times 0.22 \mu\text{F}^2 + 1 \times 4.7 \mu\text{F}^1$	Select a small capacitor with low ESR. Do not connect any loads to VDD_SNVS_CAP.
USB_OTG1_VBUS USB_OTG2_VBUS	$1 \times 1 \mu\text{F}^1$	10-V rated.
VDDA_ADC_3P3	$1 \times 0.22 \mu\text{F}^2 + 1 \times 1 \mu\text{F}^1$	Place the bypass capacitors next to ball N14.
NVCC_SD0	$1 \times 0.1 \mu\text{F} + 1 \times 4.7 \mu\text{F}^1$	Place the bypass capacitors next to ball J6.
NVCC_SD1	$1 \times 0.1 \mu\text{F} + 1 \times 4.7 \mu\text{F}^1$	Place the bypass capacitors next to ball K5.
NVCC_EMC	$2 \times 0.1 \mu\text{F} + 1 \times 4.7 \mu\text{F}^1$	Place the bypass capacitors next to balls F5 and E6.
NVCC_GPIO	$3 \times 0.1 \mu\text{F} + 1 \times 4.7 \mu\text{F}^1$	Place the bypass capacitors next to balls E9, F10, and J10.

1. For the 4.7- $\mu\text{F}$  capacitors, use the 0402 package.
2. For the 0.22- $\mu\text{F}$  capacitors, use the 0402 package.
3. For the 22- $\mu\text{F}$  capacitors, the 0603 package is preferred; 0805 and 1206 packages are acceptable.

**Table 3. Power sequence and recommendations**

Item	Recommendation	Description
1. Power sequence	Comply with the power-up/power-down sequence guidelines (as described in the data sheet) to guarantee a reliable operation of the device.	Any deviation from these sequences may result in these situations: <ul style="list-style-type: none"> <li>Excessive current during the power-up phase</li> <li>Prevention of the device from booting</li> <li>Irreversible damage to the processor (worst-case scenario)</li> </ul>
2. SNVS domain signals	Do not overload the coin cell backup power rail VDD_SNVS_IN. Note that these I/Os are associated with VDD_SNVS_IN (most inputs have on-chip pull resistors and do not require external resistors): <ul style="list-style-type: none"> <li>PMIC_STBY_REQ—configurable output</li> <li>PMIC_ON_REQ—push-pull output</li> <li>TEST_MODE—on-chip pulldown</li> <li>WAKEUP—the GPIO that wakes the SoC up in the SNVS mode</li> </ul>	Concerning i.MX RT1050/RT1060: <ul style="list-style-type: none"> <li>When VDD_SNVS_IN = VDD_HIGH_IN in the SNVS domain, the current is drawn from both equally.</li> <li>When VDD_HIGH_IN &gt; VDD_SNVS_IN, VDD_HIGH_IN supplies all the SNVS domain current and the current flows into VDD_SNVS_IN to charge the coin cell battery.</li> <li>When VDD_SNVS_IN &gt; VDD_HIGH_IN, VDD_SNVS_IN supplies current to SNVS, and a small leakage current flows into VDD_HIGH_IN.</li> </ul>
3. Power ripple	Maximum ripple voltage limitation.	The common limitation for the ripple noise shall be less than 5 % Vp-p of the supply voltage average value. The related power rails affected are VDD_XXX_IN and VDD_XXX_CAP.
4. VDD_SNVS_IN and VDD_HIGH_IN	If VDD_SNVS_IN is directly supplied by a coin cell battery, a schottky diode is required between VDD_HIGH_IN and VDD_SNVS_IN. The cathode is connected to VDD_SNVS_IN. Alternately, VDD_HIGH_IN and VDD_SNVS_IN can be tied together if the real-time clock function is not needed during the system power-down.	When no power is supplied to VDD_SNVS_IN, the diode limits the voltage difference between the two on-chip SNVS power domains to approximately 0.3 V. The processor allows the current to flow between the two SNVS power domains, proportionally to the voltage difference.

- Power Up Sequence Requirement
  - VDD\_SNVS\_IN supply must be turned on before any other power supply or be connected (shorted) with VDD\_HIGH\_IN supply
  - If a coin cell is used to power VDD\_SNVS\_IN, then ensure that it is connected before any other supply is switched on
  - When internal DCDC is enabled, external delay circuit is required to delay the “DCDC\_PSWITCH” signal at least 1 ms after DCDC\_IN is stable
  - POR\_B must be held low during the entire power up sequence
- Power Down Sequence Requirement
  - VDD\_SNVS\_IN supply must be turned off after any other power supply or be connected (shorted) with VDD\_HIGH\_IN supply
  - If a coin cell is used to power VDD\_SNVS\_IN, then ensure that it is removed after any other supply is switched off

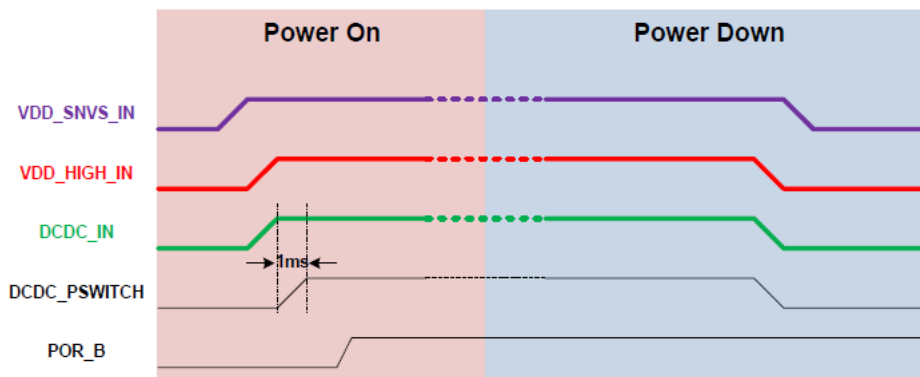

**Figure 1. Power up and power down sequence**

- For IMXRT1050-EVKB /MIMXRT1060-EVK, see [Figure 2](#).
  - First, it powers up SNVS.
  - PMIC\_REQ\_ON is then switched on to enable the external DC/DC to power up other power domains.
  - DCDC\_PSWITCH is delayed more than 1ms to switch the internal DCDC on.
  - DCDC\_OUT output powers the VDD\_SOC\_IN.
  - The ON/OFF button is used to switch PMIC\_REQ\_ON on/off to control power modes.
  - The RESET button and the WDOG output are used to reset the system power.

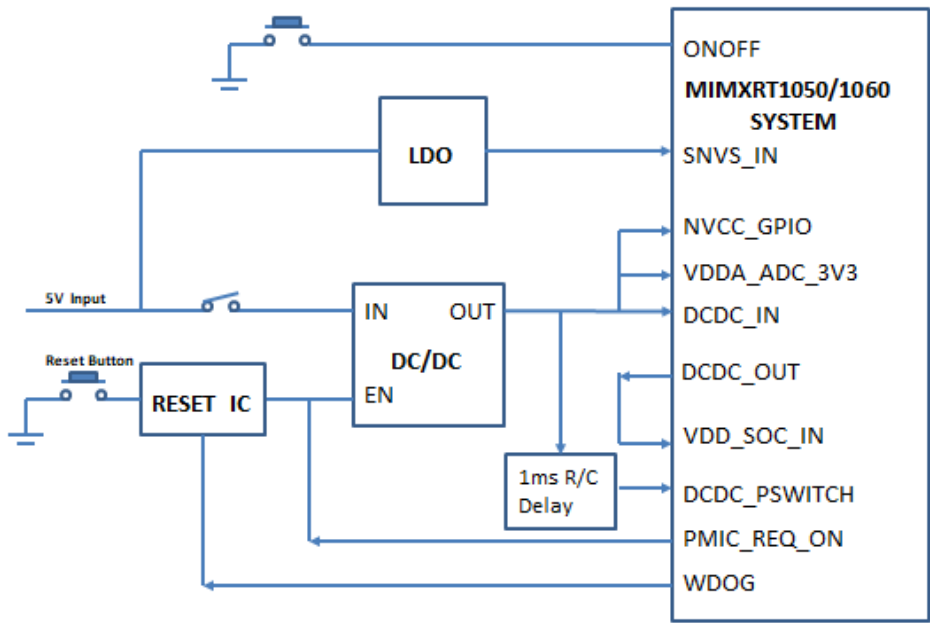

Figure 2. Power control diagram

- About on chip DC/DC module

The internal DC/DC switching frequency is about 1.5 MHz. The DC/DC requires external inductor and capacitors, the illustration is as below [Figure 3](#), please pay attention to below items:

- The recommended value for the external inductor is about 4.7~10 uH , saturation current >1A, ESR < 0.2 Ohm.
- The external buck capacitor total is about 33uF, this includes all the capacitors used on DCDC\_OUT and VDD\_SOC\_IN.
- DCDC\_PSWITCH should delay 1ms with respect to DCDC\_IN to guarantee that DCDC\_IN is stable before the DC/DC starts up.
- If you want to bypass internal DC/DC, you still need to power DCDC\_IN. DCDC\_PSWITCH should be grounded to disable the DC/DC, and DCDC\_LP should be left floating.
- Try to keep the DC/DC current loop as small as possible to avoid EMI issues.

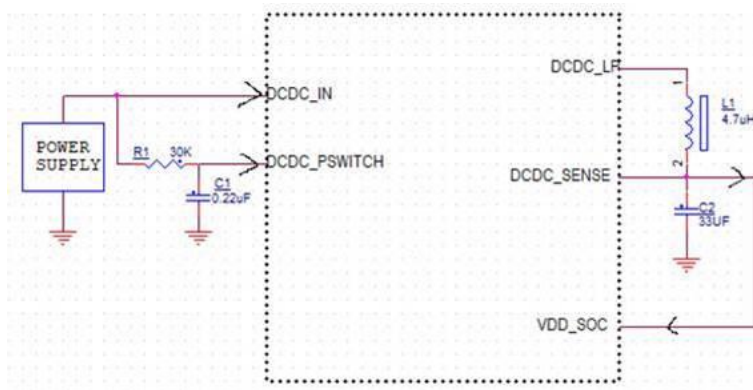
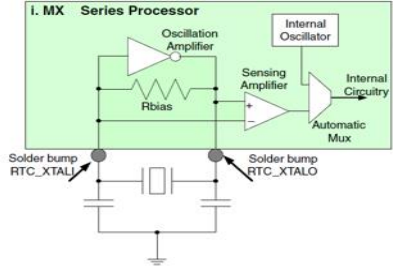

Figure 3. DC/DC function diagram

## 4. Clocks

See [Table 4](#) for the clock configuration. The 32.768-kHz and 24-MHz oscillators are used for the EVK design.

**Table 4. Clocks' configurations**

Signal name	Recommended connections	Description
1. RTC_XTALI/RTC_XTALO	 <p>For the precision 32.768-kHz oscillator, connect a crystal between RTC_XTALI and RTC_XTALO. Choose a crystal with a maximum ESR (Equivalent Series Resistance) of 100 k and follow the manufacturer's recommendation for the loading capacitance. Do not use an external biasing resistor because the bias circuit is on the chip.</p>	<p>To hit the exact oscillation frequency, the board capacitors must be reduced to account for the board and chip parasitics. The integrated oscillation amplifier is self-biasing, but relatively weak. Care must be taken to limit the parasitic leakage from RTC_XTALI and RTC_XTALO to either the power or the ground (&gt;100 M). This de-biases the amplifier and reduces the start-up margin.</p>
	<p>For the external kHz source (if feeding an external clock into the device), RTC_XTALI can be driven DC-coupled with RTC_XTALO floating or driven by a complimentary signal.</p>	<p>If you want to feed an external low-frequency clock into RTC_XTALI, the RTC_XTALO pin must remain unconnected or driven by a complementary signal. The logic level of this forcing clock must not exceed the VDD_SNVS_CAP level and the frequency shall be &lt;100 kHz under the typical conditions.</p>
	<p>An on-chip loose-tolerance ring oscillator of approximately 40 kHz is available. If RTC_XTALI is tied to GND and RTC_XTALO is floating, the on-chip oscillator is engaged automatically.</p>	<p>When a high-accuracy real-time clock is not required, the system may use the on-chip 40-kHz oscillator. The tolerance is <math>\pm 50\%</math>. The ring oscillator starts faster than the external crystal and is used until the external crystal reaches a stable oscillation. The ring oscillator also starts automatically if no clock is detected at RTC_XTALI at any time.</p>
2. XTALI/XTALO	<p>For the precision 24-MHz oscillator, connect a fundamental-mode crystal between XTALI and XTALO. An typical 80 ESR crystal rated for a maximum drive level of 250 <math>\mu\text{W}</math> is acceptable. Alternately, a typical 50 ESR crystal rated for a maximum drive level of 200 <math>\mu\text{W}</math> may be used.</p>	<p>The SDK software requires 24 MHz on XTALI/XTALO. The crystal can be eliminated if an external 24-MHz oscillator is available in the system. In this case, please refer to section of Bypass Configuration (24 MHz) from the reference manual. There are three configurations that can be utilized, but configuration 2 is recommended. The logic level of this forcing clock must not exceed the NVCC_PLL level.</p>



**Table 4. Clocks' configurations**

Signal name	Recommended connections	Description
		If this clock is used as a reference for the USB, then there are strict frequency tolerance and jitter requirements. See the OSC24M chapter and the relevant interface specifications chapters for details.
	Bias XTALI with a 2.2-M resistor to GND. Mount the resistor close to the XTALI ball.	The XTALI bias must be adjusted externally to ensure a reasonable start-up time.
3.CCM_CLK1_P/ CCM_CLK1_N	One general-purpose differential high-speed clock input/output (LVDS I/O) is provided. It is for internal use only	It is used only for internal test, please make CLK1_N/P pairs remain unconnected.

## 5. Debugging and programming

See [Table 5](#) for the JTAG interface summary and recommendation.

### NOTE

For RT1050/RT1060 silicon, it defaults to be in SWD mode instead of JTAG.

In order to enable RT1050EVKB/RT1060EVK JTAG instead of SWD port(by default), please follow below steps:

1. Burn fuse DAP\_SJC\_SWD\_SEL from '0' to '1' to choose JTAG.
2. DNP R323,R309,R152 to isolate JTAG multiplexed signals.
3. Keep off J47 to J50 to isolate board level debugger.

The IMXRT1050-EVKB /MIMXRT1060-EVK, also features an OpenSDA, which makes it easier to debug without an external debugger. At the same time, next version EVK board will change to LPC4322 based FREELINK which implement the same function as K20 based OpenSDA.

**Table 5. JTAG interface summary**

JTAG signals	I/O type	On-chip termination	External termination
JTAG_TCK	Input	47 k $\Omega$ pull-up	Not required; can use 10 k $\Omega$ pull-up
JTAG_TMS	Input	47 k $\Omega$ pull-up	Not required; can use 10 k $\Omega$ pull-up
JTAG_TDI	Input	47 k $\Omega$ pull-up	Not required; can use 10 k $\Omega$ pull-up
JTAG_TDO	3-state output	100 k $\Omega$ pull-up	Do not use pull-up or pull-down
JTAG_TRSTB	Input	47 k $\Omega$ pull-up	Not required; can use 10 k $\Omega$ pull-up
JTAG_MOD	Input	100 k $\Omega$ pull-up	Use 4.7 k $\Omega$ pull-down or tie to GND

**Table 6. JTAG recommendation**

Signals	Recommendation	Description
1. JTAG_TDO	Do not add external pull-up or pull-down resistors on JTAG_TDO.	JTAG_TDO is configured with an on-chip keeper circuit, such that the floating condition is actively eliminated if an external pull resistor is not present. An external pull resistor on JTAG_TDO is detrimental. See <a href="#">Table 5</a> for a summary of the JTAG interface.
2. All JTAG Signals	Ensure that the on-chip pull-up/pull-down configuration is followed if external resistors are used with the JTAG signals (except for JTAG_TDO). For example, do not use an external pull-down on an input that has an on-chip pull-up.	External resistors can be used with all JTAG signals except for JTAG_TDO, but they are not required. See <a href="#">Table 5</a> for a summary of the JTAG interface.
3. JTAG_MOD	JTAG_MOD is called SJC_MOD in some documents. Both names refer to the same signal. JTAG_MOD shall be externally connected to GND for normal operation in a system. The termination to GND through an external pull-down resistor is allowed. Use a 4.7-kΩ resistor.	When JTAG_MOD is low, the JTAG interface is configured for a common software debug, adding all the system TAPs to the chain. When JTAG_MOD is high, the JTAG interface is configured to a mode compliant with the IEEE 1149.1 standard.

**Table 7. OpenSDA recommendation**

Signals	Recommendation	Description
1. SWD_DIO	Connect to the K20/LPC4322 signal through a buffer	The OpenSDA in the EVK board is implemented as a debugger, which eliminates the cost for the users.
2. SWD_CLK	Connect to the K20/LPC4322 signal through a buffer	
3. UART_TXD/UART_RXD	Connect to the K20/LPC4322 signal through a buffer	The UART signals connected to K20/LPC4322 realize a virtual COM port for the OpenSDA USB for debugging.

The ROM’s Serial Downloader mode provides a means to download a program image to the chip over USB or UART serial connection. In this mode, typically a host PC can communicate to the ROM bootloader using serial download protocol. NXP’s ROM flashloader also uses these same serial connections. It is strongly recommended for all boards to make at least one of the serial downloader ports (USB1 or UART1) available to be able to make use of NXP’s image and fuse programming enablement.

**Table 8. Serial downloader I/Os table**

Signals	Recommendation	Description
---------	----------------	-------------

1. UART1	The Serial Downloader provides a means to download a program image to the chip over the USB and UART serial connections. In this mode, ROM programs WDOG1 for a time-out specified by the fuse WDOG Time-out Select (See the Fusemap chapter for details) if the WDOG_ENABLE eFuse is 1 and continuously polls for the USB and UART connection.	First, the ROM code polls the UART1 signals from TXD1/RXD1. Add a 10-kΩ pull up resistor to the TXD1/RXD1 pins to avoid an invalid trigger of the UART port in the serial download mode.
2. USB1		If there is no polling activity from UART1 in the serial download mode, the ROM code acts as an HID device for PC downloading.

## 6. Boot, reset, and miscellaneous

See [Table 9](#) for the boot, reset, and miscellaneous configurations, such as ON/OFF, TEST\_MODE, NC pins, and other.

**Table 9. Boot configuration**

Item	Recommendation	Description
1. BOOT_CFG[11:0]	The BT_CFG[] signals are required for a proper functionality and operation and shall not be left floating during development if BT_CFG[] fuses and BT_FUSE_SEL are not configured.	See the “System Boot” chapter in your chip reference manual for the correct boot configuration. Note that an incorrect setting may result in an improper boot sequence.
2. BOOT_MODE[1:0]	For BOOT_MODE1 and BOOT_MODE0, use one of these options to achieve logic 0: <ul style="list-style-type: none"> <li>• Tie to GND through any-value external resistor</li> <li>• Tie directly to GND</li> </ul> For logic 1, use one of these options: <ul style="list-style-type: none"> <li>• Tie directly to the NVCC_GPIO_XX rail</li> <li>• Tie to the NVCC_GPIO_XX rail through an external 10-kΩ resistor.</li> </ul> A value of 4.7 kΩ is preferred for high-noise environments. If a switch control is desired, no external pull-down resistors are necessary. Simply connect the SPST switches directly to the NVCC_GPIO_XX rail.	BOOT_MODE1 and BOOT_MODE0 each have on-chip pull-down devices with a nominal value of 100 kΩ, a projected minimum of 60 kΩ, and a projected maximum of 140 kΩ. When the on-chip fuses determine the boot configuration, both boot mode inputs can be disconnected.
3. BOOT_CFG and BOOT_MODE signals multiplexed with LCD signals	To reduce incorrect boot-up mode selections, do one of the following: <ul style="list-style-type: none"> <li>• Use the LCD boot interface lines only as processes or outputs. Make sure that the LCD boot interface lines are not loaded down (such that the level is interpreted as low during the powerup) when the intent is to be at a high level, or the other way round.</li> <li>• If the LCD boot signal must be configured as an input, isolate the LCD signal from the target driving source with an analog switch and apply the logic value with a second analog switch. Alternately, the peripheral devices with 3-state outputs may be used. Ensure that the output is high-impedance.</li> </ul>	Using the LCD boot interface lines as inputs may result in a wrong boot because of the source overcoming the pull resistor value. A peripheral device may require the LCD signal to have an external or on-chip resistor to minimize signal floating. If the usage of the LC boot signal affects the peripheral device, then an analog switch, an open collector buffer, or an equivalent shall isolate the path. A pull-up or pull-down resistor at the peripheral device may be required to maintain the desired logic level. See the switch or device data sheet for the operating specifications.

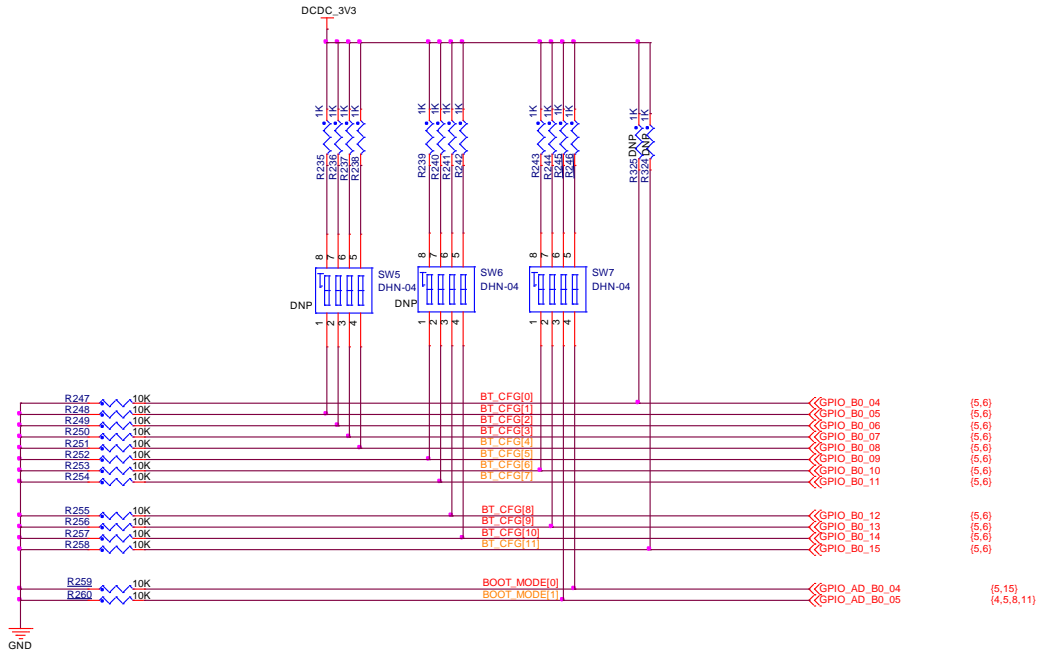

Figure 4. Boot mode setting

Table 10. Reset and miscellaneous recommendations

Item	Recommendation	Description
1. POR_B	<p>If the external POR_B signal is used to control the processor POR, then POR_B must be immediately asserted at the powerup and remain asserted until the VDD_HIGH_CAP and VDD_SNVS_CAP supplies are stable. VDD_SOC_IN may be applied in either order with no restrictions. external reset IC is required to feed the SRC_POR_B.</p>	<p>See the “System Boot” chapter in your chip reference manual for the correct boot configuration. Note that an incorrect setting may result from an improper boot sequence. POR_B signal has internal 100K pull up to SNVS domain, should pull up to VDD_SNVS_IN if need to add external pull up resistor, otherwise it will cause additional leakage during SNVS mode. It's recommended to add the external reset IC to the circuit to guarantee POR_B is properly processed during power up/down, please refer to the EVK design for details.</p> <p>Note:</p> <ol style="list-style-type: none"> <li>1. As the Low DCDC_IN detection threshold is 2.6 V, the reset IC's reset threshold must be higher than 2.6 V, then the whole chip is reset before the internal DCDC module reset to guarantee the chip safety during power down.</li> <li>2. For power on reset, on any conditions ones need to make sure the voltage on DCDC_PSWITCH PIN is below 0.5 V before power up.</li> </ol>

2. ON/OFF	For portable applications, the ON/OFF input may be connected to the ON/OFF SPST push-button. The on-chip debouncing is provided, and this input has an on-chip pullup. If not used, ON/OFF can be a no-connect. A 4.7-kΩ to 10-kΩ series resistor can be used when the current drain is critical.	A brief connection to GND in the OFF mode causes the internal power management state machine to change the state to ON. In the ON mode, a brief connection to GND generates an interrupt (intended to be a software-controllable power-down). Approximately five seconds (or more) to GND causes a forced OFF. Both boot mode inputs can be disconnected.
3. TEST_MODE	The TEST_MODE input is internally connected to an on-chip pull-down device. You may either float this signal or tie it to GND.	This input is reserved for NXP manufacturing use.
4. GPANAIO	GPANAIO must be a no-connect.	This output is reserved for NXP manufacturing use.
5. NC pin	The NC contacts are no-connect and shall float.	Depending on the feature set, some versions of ICs may have the NC contacts connected inside the BGA.

**Table 11. ROM Bootloader Peripheral PinMux**

Peripheral	Instance	Port (IO function)	PAD	Mode	Use
LPUART	1	LPUART1_TX	GPIO_AD_B0_12	ALT2	Can be used for serial downloader mode Refer to Serial Downloader in Reference Manual for more information.
		LPUART1_RX	GPIO_AD_B0_13	ALT2	
LPSPi	1	LPSPi1_SCK	GPIO_SD_B0_00	ALT4	Serial NOR/EEPROM connected to one of the LPSPi ports can be used as a recovery device.  Refer to Recovery devices in Reference Manual for more information.  Note: recovery device boot is disabled by default. Fuses must be blown to enable and configure this option.
		LPSPi1_SDO	GPIO_SD_B0_02	ALT4	
		LPSPi1_SDI	GPIO_SD_B0_03	ALT4	
		LPSPi1_PCS0	GPIO_SD_B0_01	ALT4	
	2	LPSPi2_SCK	GPIO_SD_B1_07	ALT4	
		LPSPi2_SDO	GPIO_SD_B1_08	ALT4	
		LPSPi2_SDI	GPIO_SD_B1_09	ALT4	
		LPSPi2_PCS0	GPIO_SD_B1_06	ALT4	
	3	LPSPi3_SCK	GPIO_AD_B0_00	ALT7	
		LPSPi3_SDO	GPIO_AD_B0_01	ALT7	
		LPSPi3_SDI	GPIO_AD_B0_02	ALT7	
		LPSPi3_PCS0	GPIO_AD_B0_03	ALT7	
	4	LPSPi4_SCK	GPIO_B0_03	ALT3	
		LPSPi4_SDO	GPIO_B0_02	ALT3	
		LPSPi4_SDI	GPIO_B0_01	ALT3	
		LPSPi4_PCS0	GPIO_B0_00	ALT3	
SEMC NAND	N/A	SEMC_DATA00	GPIO_EM_C_00	ALT0	Parallel NAND flash connected to the SEMC is a primary boot option. Refer to Parallel NAND flash Boot over SEMC in Reference Manual for more information.  Note: By default SEMC_CSX0 is used as the chip select. Other chip selects can be used, but fuses must be blown to select these configurations (GPIO overrides cannot be
		SEMC_DATA01	GPIO_EM_C_01	ALT0	
		SEMC_DATA02	GPIO_EM_C_02	ALT0	
		SEMC_DATA03	GPIO_EM_C_03	ALT0	
		SEMC_DATA04	GPIO_EM_C_04	ALT0	
		SEMC_DATA05	GPIO_EM_C_05	ALT0	
		SEMC_DATA06	GPIO_EM_C_06	ALT0	
		SEMC_DATA07	GPIO_EM_C_07	ALT0	
		SEMC_DATA08	GPIO_EM_C_30	ALT0	
		SEMC_DATA09	GPIO_EM_C_31	ALT0	
		SEMC_DATA10	GPIO_EM_C_32	ALT0	
		SEMC_DATA11	GPIO_EM_C_33	ALT0	
SEMC_DATA12	GPIO_EM_C_34	ALT0			

Boot, reset, and miscellaneous

		SEMC_DATA13	GPIO_EMC_35	ALT0	used to configure this option).
		SEMC_DATA14	GPIO_EMC_36	ALT0	
		SEMC_DATA15	GPIO_EMC_37	ALT0	
		SEMC_ADDR09	GPIO_EMC_18	ALT0	
		SEMC_ADDR11	GPIO_EMC_19	ALT0	
		SEMC_ADDR12	GPIO_EMC_20	ALT0	
		SEMC_BA1	GPIO_EMC_22	ALT0	
		SEMC_RDY	GPIO_EMC_40	ALT0	
		SEMC_CSX0	GPIO_EMC_41	ALT0	
		SEMC_CSX1	GPIO_B0_00	ALT6	
		SEMC_CSX2	GPIO_B0_01	ALT6	
		SEMC_CSX3	GPIO_B0_02	ALT6	
		SEMC_ADDR08	GPIO_EMC_17	ALT0	
SEMC NOR	N/A	SEMC_DATA00	GPIO_EMC_00	ALT0	
		SEMC_DATA01	GPIO_EMC_01	ALT0	
		SEMC_DATA02	GPIO_EMC_02	ALT0	
		SEMC_DATA03	GPIO_EMC_03	ALT0	
		SEMC_DATA04	GPIO_EMC_04	ALT0	
		SEMC_DATA05	GPIO_EMC_05	ALT0	
		SEMC_DATA06	GPIO_EMC_06	ALT0	
		SEMC_DATA07	GPIO_EMC_07	ALT0	
		SEMC_DATA08	GPIO_EMC_30	ALT0	
		SEMC_DATA09	GPIO_EMC_31	ALT0	
		SEMC_DATA10	GPIO_EMC_32	ALT0	
		SEMC_DATA11	GPIO_EMC_33	ALT0	
		SEMC_DATA12	GPIO_EMC_34	ALT0	
		SEMC_DATA13	GPIO_EMC_35	ALT0	
		SEMC_DATA14	GPIO_EMC_36	ALT0	
		SEMC_DATA15	GPIO_EMC_37	ALT0	
		SEMC_ADDR00	GPIO_EMC_09	ALT0	
		SEMC_ADDR01	GPIO_EMC_10	ALT0	
		SEMC_ADDR02	GPIO_EMC_11	ALT0	
		SEMC_ADDR03	GPIO_EMC_12	ALT0	
		SEMC_ADDR04	GPIO_EMC_13	ALT0	
		SEMC_ADDR05	GPIO_EMC_14	ALT0	
		SEMC_ADDR06	GPIO_EMC_15	ALT0	
		SEMC_ADDR07	GPIO_EMC_16	ALT0	
		SEMC_ADDR11	GPIO_EMC_19	ALT0	
		SEMC_ADDR12	GPIO_EMC_20	ALT0	
		SEMC_BA0	GPIO_EMC_21	ALT0	
		SEMC_BA1	GPIO_EMC_22	ALT0	
		SEMC_CSX0	GPIO_EMC_41	ALT0	
		SEMC_CSX1	GPIO_B0_00	ALT6	
		SEMC_CSX2	GPIO_B0_01	ALT6	
		SEMC_CSX3	GPIO_B0_02	ALT6	
		SEMC_ADDR08	GPIO_EMC_17	ALT0	
SD	1	USDHC1_CD_B	GPIO_SD_B1_12	ALT6	eMMC/MMC or SD/eSD connected to one of the USDHC ports is a primary boot option. Refere to Expansion device in Reference Manual for more information.
		USDHC1_VSELECT	GPIO_B1_14	ALT6	
		USDHC1_RESET_B	GPIO_B1_15	ALT6	
		USDHC1_CMD	GPIO_SD_B0_00	ALT0	
		USDHC1_CLK	GPIO_SD_B0_01	ALT0	
		USDHC1_DATA0	GPIO_SD_B0_02	ALT0	
		USDHC1_DATA1	GPIO_SD_B0_03	ALT0	
		USDHC1_DATA2	GPIO_SD_B0_04	ALT0	
		USDHC1_DATA3	GPIO_SD_B0_05	ALT0	
	2	USDHC2_RESET_B	GPIO_SD_B1_06	ALT0	
		USDHC2_CMD	GPIO_SD_B1_05	ALT0	
		USDHC2_CLK	GPIO_SD_B1_04	ALT0	
		USDHC2_DATA0	GPIO_SD_B1_03	ALT0	

		USDHC2_DATA1	GPIO_SD_B1_02	ALT0	
		USDHC2_DATA2	GPIO_SD_B1_01	ALT0	
		USDHC2_DATA3	GPIO_SD_B1_00	ALT0	
		USDHC2_DATA4	GPIO_SD_B1_08	ALT0	
		USDHC2_DATA5	GPIO_SD_B1_09	ALT0	
		USDHC2_DATA6	GPIO_SD_B1_10	ALT0	
		USDHC2_DATA7	GPIO_SD_B1_11	ALT0	
FlexSPI NOR Flash - QSPI	1	FLEXSPI_B_DATA3	GPIO_SD_B1_00	ALT1	<p>QSPI memory attached to FlexSPI is a primary boot option. Refer to Serial NOR Flash Boot via FlexSPI in Reference Manual for more information. The ROM will read the 512-byte FlexSPI described in FlexSPI Serial NOR Flash Boot Operation in Reference Manual using the non italicized pins.</p> <p>Note: ROM can configure the italicized signals based on the FlexSPI NOR configuration parameters provided.</p>
		FLEXSPI_B_DATA2	GPIO_SD_B1_01	ALT1	
		FLEXSPI_B_DATA1	GPIO_SD_B1_02	ALT1	
		FLEXSPI_B_DATA0	GPIO_SD_B1_03	ALT1	
		FLEXSPI_B_SCLK	GPIO_SD_B1_01	ALT1	
		FLEXSPI_B_DQS	GPIO_SD_B0_05	ALT4	
		FLEXSPI_B_SS0_B	GPIO_SD_B0_04	ALT4	
		FLEXSPI_B_SS1_B	GPIO_SD_B0_01	ALT6	
		FLEXSPI_A_DQS	GPIO_SD_B1_05	ALT1	
		FLEXSPI_A_SS0_B	GPIO_SD_B1_06	ALT1	
		FLEXSPI_A_SS1_B	GPIO_SD_B0_00	ALT6	
		FLEXSPI_A_SCLK	GPIO_SD_B1_07	ALT1	
		FLEXSPI_A_DATA0	GPIO_SD_B1_08	ALT1	
		FLEXSPI_A_DATA1	GPIO_SD_B1_09	ALT1	
		FLEXSPI_A_DATA2	GPIO_SD_B1_10	ALT1	
		FLEXSPI_A_DATA3	GPIO_SD_B1_11	ALT1	
FlexSPI NOR - QSPI - 2nd Option	1	FLEXSPI_A_SS0_B	GPIO_AD_B1_15	ALT0	<p>QSPI memory attached to FlexSPI is a primary boot option. Refer to Serial NOR Flash Boot via FlexSPI in Reference Manual for more information. The ROM will read the 512-byte FlexSPI NOR configuration parameters described in FlexSPI Serial NOR Flash Boot Operation Reference Manual using the non-italicized pins.</p> <p>Note: These pins are a secondary pinout option for FlexSPI serial NOR flash boot.</p>
		FLEXSPI_A_SCLK	GPIO_AD_B1_14	ALT0	
		FLEXSPI_A_DQS	GPIO_AD_B1_09	ALT0	
		FLEXSPI_A_DATA0	GPIO_AD_B1_13	ALT0	
		FLEXSPI_A_DATA1	GPIO_AD_B1_12	ALT0	
		FLEXSPI_A_DATA2	GPIO_AD_B1_11	ALT0	
		FLEXSPI_A_DATA3	GPIO_AD_B1_10	ALT0	
FlexSPI NOR Flash - Octal	1	FLEXSPI_B_DATA3	GPIO_SD_B1_00	ALT1	<p>Octal serial NOR flash memory attached to FlexSPI is a primary boot option. Refer to Serial NOR Flash Boot via FlexSPI in Reference Manual for more information. The ROM will read the 512-byte FlexSPI NOR configuration parameters described in FlexSPI Serial NOR Flash Boot Operation in Reference Manual using the non-italicized pins</p> <p>For 8-bit wide memories the FLEXSPI_B_DATA[3:0] pins are combined with the FLEXSPI_A_DATA[3:0] lines to</p>
		FLEXSPI_B_DATA2	GPIO_SD_B1_01	ALT1	
		FLEXSPI_B_DATA1	GPIO_SD_B1_02	ALT1	
		FLEXSPI_B_DATA0	GPIO_SD_B1_03	ALT1	
		FLEXSPI_B_SCLK	GPIO_SD_B1_01	ALT1	
		FLEXSPI_B_DQS	GPIO_SD_B0_05	ALT4	
		FLEXSPI_B_SS0_B	GPIO_SD_B0_04	ALT4	
		FLEXSPI_B_SS1_B	GPIO_SD_B0_01	ALT6	
		FLEXSPI_A_DQS	GPIO_SD_B1_05	ALT1	
		FLEXSPI_A_SS0_B	GPIO_SD_B1_06	ALT1	
		FLEXSPI_A_SS1_B	GPIO_SD_B0_00	ALT6	
		FLEXSPI_A_SCLK	GPIO_SD_B1_07	ALT1	
		FLEXSPI_A_DATA0	GPIO_SD_B1_08	ALT1	
		FLEXSPI_A_DATA1	GPIO_SD_B1_09	ALT1	
		FLEXSPI_A_DATA2	GPIO_SD_B1_10	ALT1	
		FLEXSPI_A_DATA3	GPIO_SD_B1_11	ALT1	

					get the full 8-bit port.  Note: ROM can configure the italicized signals based on the FlexSPI NOR configuration parameters provided.
FlexSPI NAND Flash	1	FLEXSPI_A_DQS	GPIO_SD_B1_05	ALT1	Serial NAND memory attached to FlexSPI is a primary boot option. Refer to Serial NAND Flash Boot over FlexSPI in Reference Manual for more information.
		FLEXSPI_A_SS0_B	GPIO_SD_B1_06	ALT1	
		FLEXSPI_A_SCLK	GPIO_SD_B1_07	ALT1	
		FLEXSPI_A_DATA0	GPIO_SD_B1_08	ALT1	
		FLEXSPI_A_DATA1	GPIO_SD_B1_09	ALT1	
		FLEXSPI_A_DATA2	GPIO_SD_B1_10	ALT1	
		FLEXSPI_A_DATA3	GPIO_SD_B1_11	ALT1	
FlexSPI RESET	.	GPIO1_IO29	GPIO_AD_B1_13	ALT5	.

**NOTE**

ROM does not support boot from FLEXSPI\_B port directly. ROM always seeks a valid Flash Configuration Block from the FLEXSPI\_A port and then re-configures the FLEXSPI controller using the valid parameters in the block read-out. This reconfiguration can include, but is not limited to, FLEXSPI\_B port support.

## 7. Layout recommendations

### 7.1. Stackup

A high-speed design requires a good stackup to have the right impedance for the critical traces.

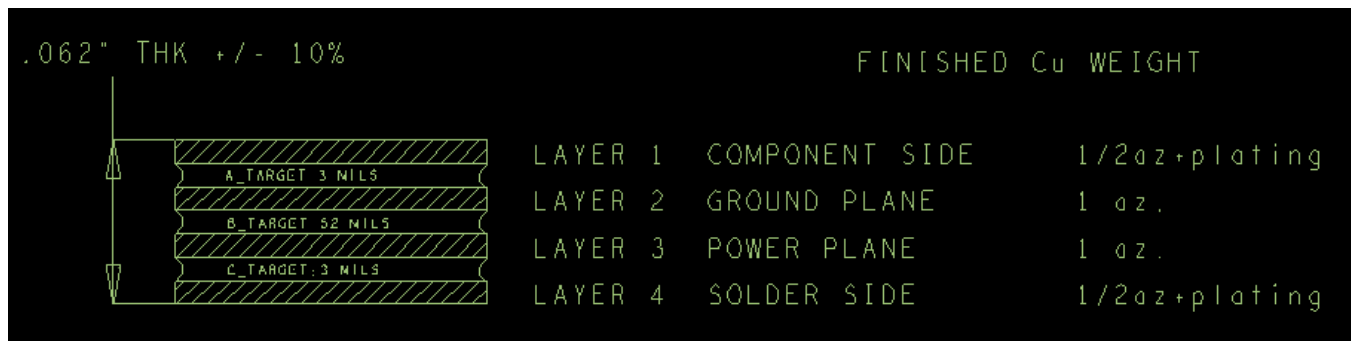

Figure 5. IMXRT1050-EVKB stackup

The constraints for the trace width depend on many factors, such as the board stackup and the associated dielectric and copper thickness, required impedance, and required current (for power traces). The stackup also determines the constraints for routing and spacing. Consider the following when designing the stackup and selecting the material for your board:

- The board stackup is critical for the high-speed signal quality.
- Preplan the impedance of the critical traces.



- The high-speed signals must have reference planes on adjacent layers to minimize crosstalk.
- The NXP reference design equals Isola FR4.
- The NXP validation boards equal Isola FR4.
- The recommended stackup is four layers, with the layer stack shown in Figure 5. The left-hand image shows the detail provided by NXP inside the fabrication detail as a part of the Gerber files. The right-hand side shows the solution suggested by the PCB fabrication company for the requirements. Figure 6 shows the IMXRT1050-EVKB PCB stackup implementation:

Layers	Single Ended		Differential			Differential		
	Trace Width (Mils)	Impedance (Ohms)	Trace Width (Mils)	Trace Spacing "Airgap" (Mils)	Impedance (Ohms)	Trace Width (Mils)	Trace Spacing "Airgap" (Mils)	Impedance (Ohms)
L1	5.00	50	4.2	6.00	100	4.70	5.00	90
L4	5.00	50				4.70	5.00	90

Figure 6. IMXRT1050-EVKB stackup implementation

## 7.2. Placement of bulk and decoupling capacitors

Place the small decoupling capacitors and the larger bulk capacitors on the bottom side of the CPU. The 0402 decoupling capacitors and the 0603 bulk capacitors must be placed as close as possible to the power balls. Placing the decoupling capacitors close to the power balls is critical to minimize inductance and ensure the high-speed transient current demand of the processor. The correct via size, trace width, and trace space are critical to preserve the adequate routing space. The recommended geometry is as follows:

- For the BGA constraint area:
  - The via type is 14/8 mils, the trace width is 4 mils, and the trace space is 3.79 mils.
- For the default area (except for the BGA):
  - The via type is 18/8 mils, the trace width is 5 mils, and the trace space is 7 mils.
  - The preferred BGA power-decoupling design layout is available at [nxp.com](http://nxp.com).
  - Use the NXP design strategy for power and decoupling.

## 7.3. FlexSPI

FlexSPI is a flexible SPI (Serial Peripheral Interface) host controller which supports two SPI channels and up to 4 external devices. Each channel supports Single/Dual/Quad/ Octal mode data transfer (1/2/4/8 bidirectional data lines). FlexSPI is the most commonly used external memory.

Please refer to section FlexSPI parameters from the datasheet, there are several sources for the internal sample clock for FlexSPI read data:

- Dummy read strobe generated by FlexSPI controller and looped back internally  
(FlexSPIIn\_MCR0[RXCLKSRC] = 0x0)
- Dummy read strobe generated by FlexSPI controller and looped back through the

DQS pad (FlexSPIn\_MCR0[RXCLKSRC] = 0x1)

- Read strobe provided by memory device and input from DQS pad

(FlexSPIn\_MCR0[RXCLKSRC] = 0x3)

So for QSPI Flash without a DQS provided by the memory, only the option of FlexSPIn\_MCR0[RXCLKSRC] = 0x1 can achieve 133 MHz SDR R/W speed, and FlexSPI\_DQS pin should be left floating.

For Octal Flash where a DQS signal is provided by the memory, need to use the option of FlexSPIn\_MCR0[RXCLKSRC] = 0x3 which can achieve 166 MHz DDR R/W, in such case FlexSPI\_DQS pin should be connected to the flash directly.

## 7.4. SDRAM

The SDRAM interface (running at up to 166 MHz) is one of the critical interfaces for the chip routing. The controlled impedance for the single-ended traces must be 50 Ω. Ideally, route all signals at the same length as the EVK board. See the layout to route all signals at the same length (±50 mils).

The SDRAM routing must be separated into two groups: data and address/control. See the EVK layout to separate all SDRAM signals into two groups:

- SEMC\_DQS signal line should be left floating.
- All data lines and DM[x]
- All address lines and control lines

For i.MX RT1050, the SDRAMs that SEMC can support need at least 9 column address lines and only 4 banks.

For i.MX RT1060, the SDRAMs that SEMC can support need at least 8 column address lines and both 2 and 4 banks.

For example:

ISSI\_SDRAM\_IS42S16100C1\_6\_5\_x16\_16Mb and WINBOND\_SDRAM\_x16\_w9816g6ch\_6\_16Mb, both two SDRAMs can be used on i.MX RT1060, but cannot be used on i.MX RT1050.

Because the IMXRT1050-EVKB is a 4-layer board design, both routing groups refer to the GND plane for the impedance control. One group is routed at the top layer (the reference plane is the second layer), while the other group is routed at the bottom layer (the reference plane is the third layer).

## 7.5. USB

Use these recommendations for the USB:

- Route the high-speed clocks and the DP and DM differential pair first.
- Route the DP and DM signals on the top (or bottom) layer of the board.
- The trace width and spacing of the DP and DM signals must meet the differential impedance requirement of 90 Ω.
- Route the traces over the continuous planes (power and ground):
  - They must not pass over any power/GND plane slots or anti-etch.

- When placing the connectors, make sure that the ground plane clearouts around each pin have ground continuity between all pins.
- Maintain the parallelism (skew-matched) between DP and DM, and match the overall differential length difference to less than 5 mils.
- Maintain the symmetric routing for each differential pair.
- Do not route the DP and DM traces under the oscillators or parallel to the clock traces (and/or data buses).
- Minimize the lengths of the high-speed signals that run parallel to the DP and DM pair.
- Keep the DP and DM traces as short as possible.
- Route the DP and DM signals with a minimum amount of corners. Use 45-degree turns instead of 90-degree turns.
- Avoid layer changes (vias) on the DP and DM signals. Do not create stubs or branches.
- Provide the ground return vias within a 50-mil distance from the signal layer-transition vias when transitioning between different reference ground planes.
- When the USB signals are not used, it is recommended that not to connect USB\_OTG1\_CHD\_B, USB\_OTG1\_DN, USB\_OTG1\_DP, USB\_OTG1\_VBUS, USB\_OTG2\_DN, USB\_OTG2\_DP, USB\_OTG2\_VBUS pads.

## 7.6. High-speed signal routing recommendations

The following list provides recommendations for routing the traces for high-speed signals. Note that the propagation delay and the impedance control must match to have a correct communication with the devices.

- The high-speed signals (SDRAM, RMII, Display, Hyperflash, SD card) must not cross gaps in the reference plane.
- Avoid creating slots, voids, and splits in the reference planes. Review the via voids to ensure that they do not create splits (space out vias).
- Provide the ground return vias within a 100-mil distance from the signal layer-transition vias when transitioning between different reference ground planes.
- A solid GND plane must be directly under the crystal-associated components, and traces.
- The clocks or strobes that are on the same layer need at least 2.5× spacing from the adjacent traces (2.5× height from the reference plane) to reduce crosstalk.
- Provide the ground return vias within a 100-mil distance from the signal layer-transition vias when transitioning between different reference ground planes.
- All synchronous modules must have the bus length matching and relative clock length control.
- For the SD module interfaces:
  - Match the data, clock, and CMD trace lengths (length delta depends on the bus rates).
  - Follow similar SDRAM rules for data, address, and control as for the SD module interfaces.

- For the RT1050/RT1060 SEMC module to support SDRAM, SEMC\_DQS pin(GPIO\_EMC\_39) should be kept floating to achieve high-speed access.
- For the RT1050/RT1060 FlexSPI module to support QSPI flash, FlexSPI\_DQS pin(GPIO\_SD\_B1\_05) should be kept floating to achieve high-speed access.

## 8. Revision history

Table summarizes the changes done to this document since the initial release.

**Table 12. Revision history**

Revision number	Date	Substantive changes
0	08/2018	Initial release
1	01/2019	Updated <a href="#">Section 7.6, "High-speed signal routing recommendations"</a> .
2	02/2019	Updated <a href="#">Section 7.6, "High-speed signal routing recommendations"</a> .
3	07/2019	Added FlexSPI section, updated Table 11, "Rom Bootloader Peripheral PinMux" and other updates.
4	10/2019	Updated Section 1, 5 and 7.4



**How to Reach Us:**

**Home Page:**

[nxp.com](http://nxp.com)

**Web Support:**

[nxp.com/support](http://nxp.com/support)

Information in this document is provided solely to enable system and software implementers to use NXP products. There are no express or implied copyright licenses granted hereunder to design or fabricate any integrated circuits based on the information in this document. NXP reserves the right to make changes without further notice to any products herein.

NXP makes no warranty, representation, or guarantee regarding the suitability of its products for any particular purpose, nor does NXP assume any liability arising out of the application or use of any product or circuit, and specifically disclaims any and all liability, including without limitation consequential or incidental damages. "Typical" parameters that may be provided in NXP data sheets and/or specifications can and do vary in different applications, and actual performance may vary over time. All operating parameters, including "typicals," must be validated for each customer application by customer's technical experts. NXP does not convey any license under its patent rights nor the rights of others. NXP sells products pursuant to standard terms and conditions of sale, which can be found at the following address:

[nxp.com/SalesTermsandConditions](http://nxp.com/SalesTermsandConditions).

While NXP has implemented advanced security features, all products may be subject to unidentified vulnerabilities. Customers are responsible for the design and operation of their applications and products to reduce the effect of these vulnerabilities on customer's applications and products, and NXP accepts no liability for any vulnerability that is discovered. Customers should implement appropriate design and operating safeguards to minimize the risks associated with their applications and products.

NXP, the NXP logo, NXP SECURE CONNECTIONS FOR A SMARTER WORLD, COOLFLUX, EMBRACE, GREENCHIP, HITAG, I2C BUS, ICODE, JCOP, LIFE VIBES, MIFARE, MIFARE CLASSIC, MIFARE DESFire, MIFARE PLUS, MIFARE FLEX, MANTIS, MIFARE ULTRALIGHT, MIFARE4MOBILE, MIGLO, NTAG, ROADLINK, SMARTLX, SMARTMX, STARPLUG, TOPFET, TRENCHMOS, UCODE, Freescale, the Freescale logo, Altivec, C 5, CodeTEST, CodeWarrior, ColdFire, ColdFire+, C Ware, the Energy Efficient Solutions logo, Kinetis, Layerscape, MagniV, mobileGT, PEG, PowerQUICC, Processor Expert, QorIQ, QorIQ Qonverge, Ready Play, SafeAssure, the SafeAssure logo, StarCore, Symphony, VortiQa, Vybrid, Airfast, BeeKit, BeeStack, CoreNet, Flexis, MXC, Platform in a Package, QUICC Engine, SMARTMOS, Tower, TurboLink, and UMEMS are trademarks of NXP B.V. All other product or service names are the property of their respective owners. Arm, AMBA, Arm Powered, Artisan, Cortex, Jazelle, Keil, SecurCore, Thumb, TrustZone, and  $\mu$ Vision are registered trademarks of Arm Limited (or its subsidiaries) in the EU and/or elsewhere. Arm7, Arm9, Arm11, big.LITTLE, CoreLink, CoreSight, DesignStart, Mali, Mbed, NEON, POP, Sensinode, Socrates, ULINK and Versatile are trademarks of Arm Limited (or its subsidiaries) in the EU and/or elsewhere. All rights reserved. Oracle and Java are registered trademarks of Oracle and/or its affiliates. The Power Architecture and Power.org word marks and the Power and Power.org logos and related marks are trademarks and service marks licensed by Power.org.

© 2018-2019 NXP B.V.

Document Number: MIMXRT105060HDUG

Rev.4  
10/2019

