

Moku:Go

Specifications



Table of contents

Moku:Go Hardware	5
Specifications.....	5
Analog I/O	5
Digital I/O.....	6
Power supplies (M1 and M2 models only).....	6
Clock reference.....	6
General characteristics.....	7
General connectivity.....	7
Hardware measurements.....	8
ADC bandwidth.....	8
ADC input noise.....	8
Compound crosstalk (ADC-ADC & DAC-ADC).....	9
Moku:Go Arbitrary Waveform Generator	10
Description.....	10
Specifications.....	11
Common.....	11
Waveform.....	11
Moku:Go Data Logger	12
Description.....	12
Specifications.....	13
Logging.....	13
Moku:Go Digital Filter Box	14
Description.....	14
Specifications.....	15
Inputs.....	15
Filter characteristics.....	15
Selecting the right IIR filter.....	17
Moku:Go FIR Filter Builder	18
Description.....	18
Specifications.....	19
Inputs.....	19
Filter characteristics.....	19
Moku:Go Frequency Response Analyzer	21
Description.....	21
Specifications.....	22
Source.....	22
Measurement.....	22
Saving Data.....	22

Moku:Go Laser Lock Box	23
Description.....	23
Specifications.....	24
Signal input.....	24
Internal demodulation local oscillator.....	24
External demodulation reference.....	24
Filter.....	25
Modulation oscillator.....	25
Scan waveform.....	26
PID Controllers.....	26
Moku:Go Lock-In Amplifier	28
Description.....	28
Specifications.....	29
Signal channel.....	29
External reference.....	29
Internal reference.....	29
Demodulator.....	30
Signal output.....	30
Moku:Go Logic Analyzer	32
Description.....	32
Specifications.....	33
Digital I/O.....	33
Horizontal characteristics.....	33
Trigger.....	33
Measurements.....	34
Protocol decoder.....	34
Saving data.....	35
Moku:Go Oscilloscope	37
Description.....	37
Specifications.....	38
Vertical characteristics.....	38
Horizontal characteristics.....	38
Trigger.....	39
Measurements.....	39
Saving data.....	40
Moku:Go PID Controller	41
Description.....	41
Specifications.....	42
Inputs.....	42
Controller.....	42
Moku:Go Phasemeter	43

Description.....	43
Specifications.....	44
Inputs	44
Measurement.....	44
Synthesizer	44
Outputs.....	45
Saving data	45
Moku:Go Spectrum Analyzer	46
Description.....	46
Specifications.....	47
Frequency	47
Amplitude	47
Moku:Go Time & Frequency Analyzer	48
Description.....	48
Specifications.....	49
Events	49
Intervals.....	49
Signal output	50
Moku:Go Waveform Generator	51
Description.....	51
Specifications.....	52
Common characteristics	52
Waveform characteristics.....	52
Modulation	53
Moku:Go Multi-Instrument Mode	55
Description.....	55
Specifications.....	56
Common characteristics	56
Moku:Go Power Supply	57
Description.....	57
Specifications.....	58
PPSU1 Output Noise	58
PPSU2 Output Noise	59
PPSU3 and PPS4 Output Noise	59

Moku:Go Hardware

Specifications

Analog I/O

Analog inputs

Channels	2
Bandwidth (-3 dB)	30 MHz into 1 M Ω
Sampling rate	125 MSa/s per channel
Resolution	12-bit
Accuracy	± 5 mV $\pm 1\%$ (10 V _{pp} input range)
Precision ¹	± 1.22 mV (10 V _{pp} input range)
Maximum voltage range	50 V _{pp} into 1 M Ω with 5X attenuation
Input impedance	1 M Ω , typically <25pF
Input coupling	AC / DC
AC coupling corner (-3 dB)	7 Hz
Input noise	160 nV/ $\sqrt{\text{Hz}}$ above 220 kHz at 10 V _{pp} input range
Connector	BNC

Analog outputs

Channels	2
Bandwidth (-3 dB)	> 20 MHz (into 50 Ω load)
Sampling rate	125 MSa/s per channel
Resolution	12-bit
Accuracy	± 5 mV $\pm 1\%$ (10 V _{pp} output range)
Precision	± 1.22 mV (10 V _{pp} output range)
Voltage range	10 V _{pp} into 1 M Ω
Output impedance	200 Ω
Output coupling	DC
Connector	BNC

¹ This measurement uses the full bandwidth of the device to determine precision. The precision is determined by the number of bits, which at full bandwidth (30 MHz) the number of bits is 12-bits. This can be improved at lower frequencies using Precision mode.

Digital I/O

Digital Interface

Channels	16
Direction	Bi-directional
Sampling rate	125 MSa/s per channel
Logic level	Input: 3.3 V, 5 V tolerant Output: 3.3 V
Impedance	Input: > 10 M Ω , < 4 pF Output: 400 Ω , < 4 pF
Connector	20-pin header

Power supplies (M1 and M2 models only)

M1 Model²

Channels	2
Voltage	Port 1: -5 V to + 5 V Port 2: 0 V to + 16 V
Current	Port 1: 0 mA to 150 mA Port 2: 0 mA to 150 mA

M2 Model

Channels	4
Voltage	Port 1: -5 V to + 5 V Port 2: 0 V to + 16 V Port 3 & 4 +0.6 V to +5 V
Current	Port 1: 0 mA to 150 mA Port 2: 0 mA to 150 mA Port 3 & 4 +0.06 A to 1 A

Clock reference

On-board clock

Frequency	125 MHz
Stability	< 25 ppm

² The Moku:Go M1 model is a legacy product and has been discontinued.

General characteristics

General and environmental characteristics

Power consumption	15 W typical 35 W With full Programmable Power Supply load (M2 model)
Power voltage range	100 to 240 V, 50/60 Hz
Temperature	Operating: 0 to +45 °C Non-operating: -10 to +60 °C

Electromagnetic compliance



General connectivity

Connectivity

Analog inputs	2 x BNC
Analog outputs	2 x BNC
Digital I/O	16 bi-directional
Power Supplies	0 (M0), 2 (M1), or 4 (M2) banana jacks plus grounding
Network	Ethernet (10/100 Base-T) M2 model Only Wi-Fi 802.11 b/g/n
USB-C port	For communication only (USB PD not supported)
DC Power	12 V magnetic power adaptor (included)

Hardware measurements

ADC bandwidth

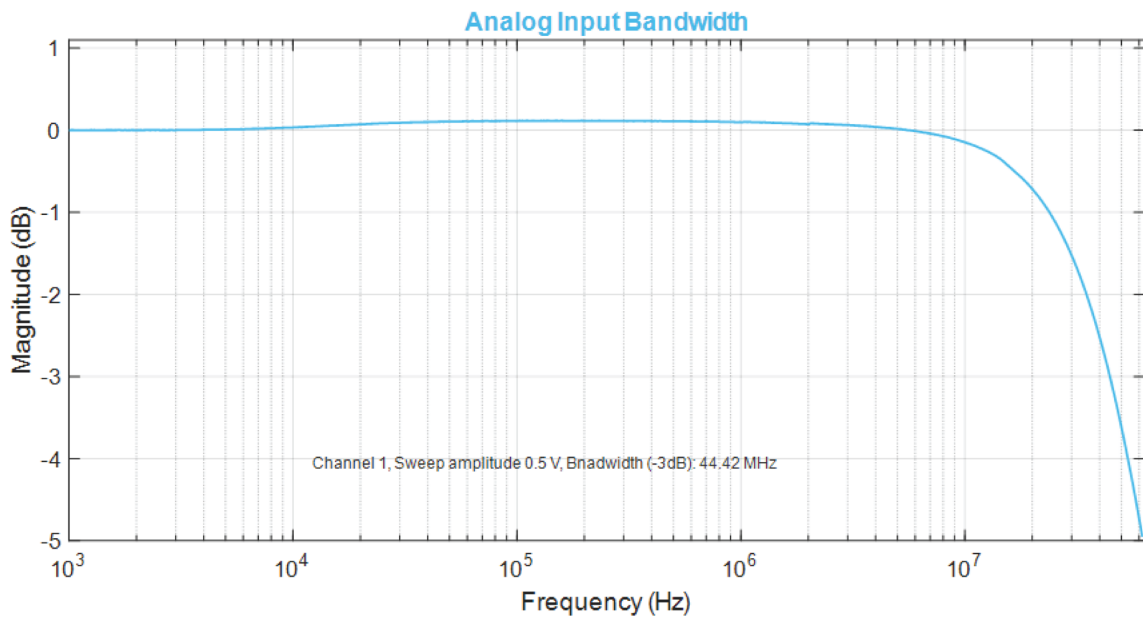

ADC input noise

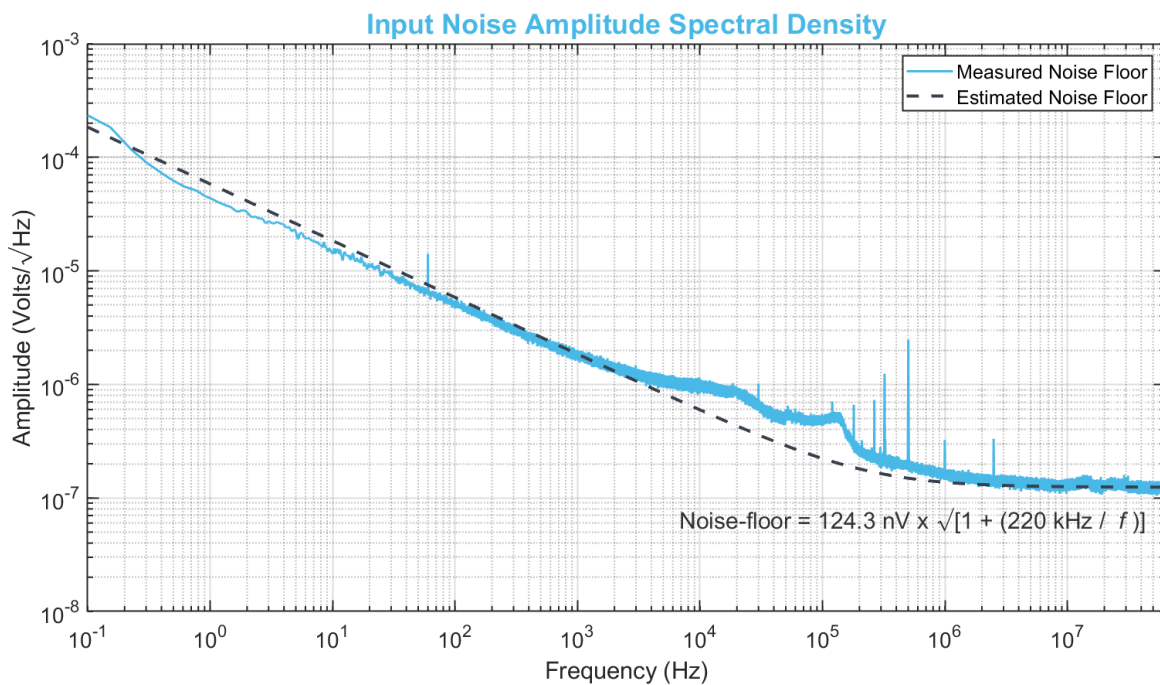

Compound crosstalk (ADC-ADC & DAC-ADC)

1 MΩ // AC coupled // 0 dB attenuation

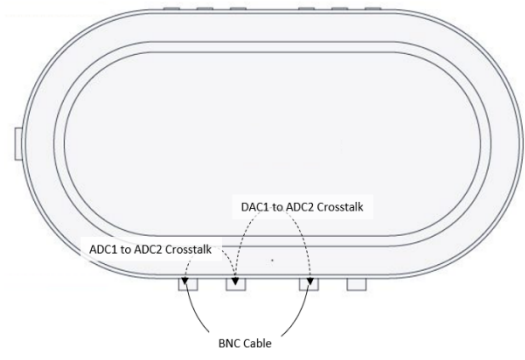
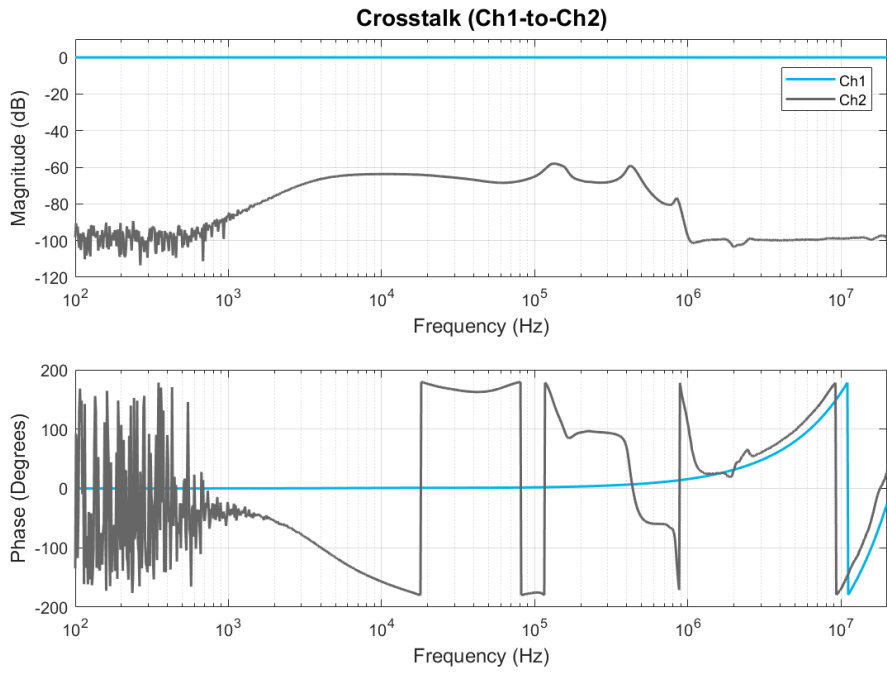

DAC 1 to ADC 2 Crosstalk
& ADC 1 to ADC 2 Crosstalk

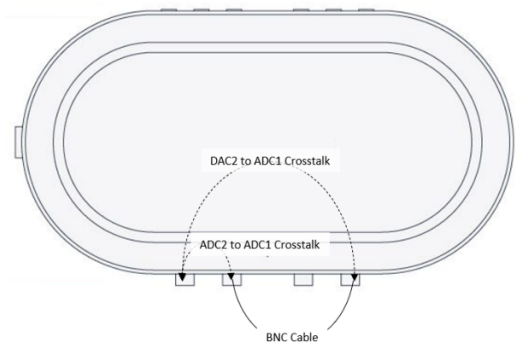
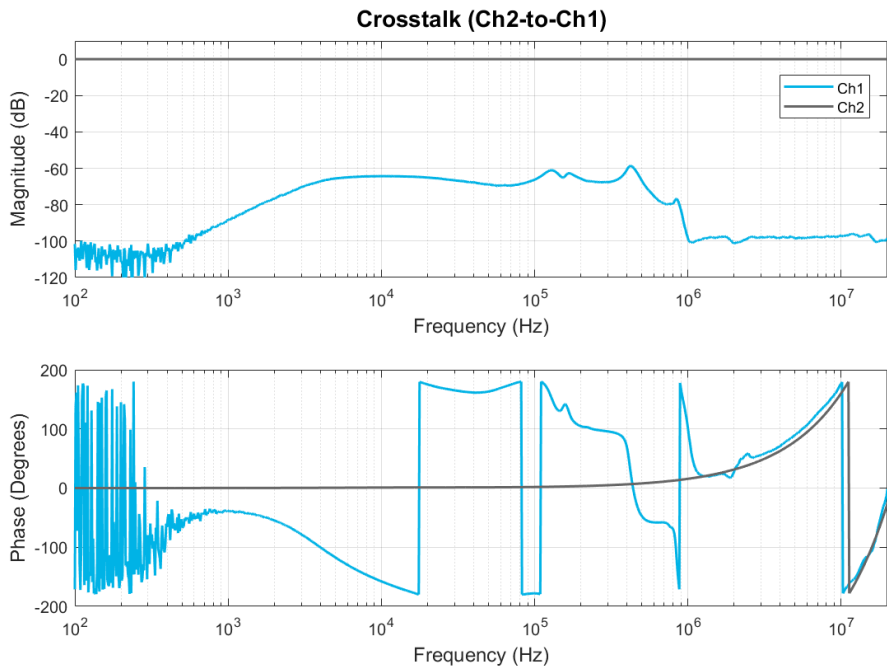

DAC 2 to ADC 1 Crosstalk
& ADC 2 to ADC 1 Crosstalk



Moku:Go Arbitrary Waveform Generator

Description

The Moku:Go Arbitrary Waveform Generator can generate custom waveforms with up to 65,536 points at sample rates of up to 125 MSa/s. Waveforms can be loaded from a file or input as a piece-wise mathematical function with up to 32 segments, enabling you to generate truly arbitrary waveforms. In burst mode, waveform generation can be triggered from input channels with Start or N Cycle modes. In pulsed mode, waveforms can be output with more than 262,144 cycles of dead time between pulses.

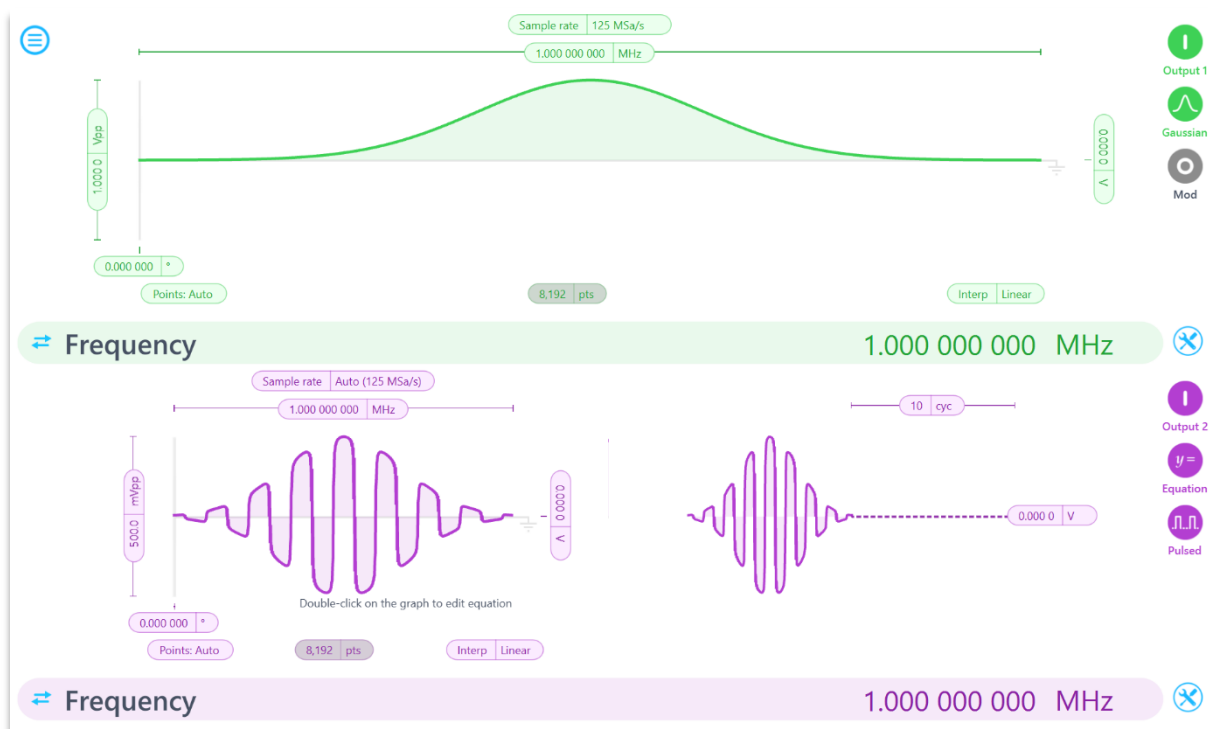

Features

- Select a pre-set waveform, load custom waveforms from a file, or describe your waveform mathematically using the in-built equation editor
- Configure pulsed arbitrary waveforms with up to 262,144 cycles of dead time between pulses
- Synchronize the phase of both output channels
- Generate arbitrary waveforms with up to 65,536 points



Specifications

Common

Overview

Channels	2
Bandwidth (-3 dB)	> 20 MHz
Sampling rate	125 M per channel
Source impedance	200 Ω
Waveforms	Sine, Gaussian, Exponential Fall, Exponential Rise, Sinc, Cardiac, Equation, Custom (from file)

Amplitude

Output voltage range	10 V _{pp} into 1 M Ω
Resolution	100 μ V _{pp}

DC offset

Voltage range	\pm 4.999 V into 1 M Ω
Resolution	100 μ V

Phase offset

Range	0° to 360°
Resolution	0.000 001°

Waveform

Custom

Maximum output rate	15.625 MSa/s	65536 points
	31.25 MSa/s	32768 points
	62.5 MSa/s	16384 points
	125 MSa/s	8192 points
Text file type	Comma- or newline-delimited text	
File import options	Clipboard, Files	
Interpolation	None, Linear	



Moku:Go Data Logger

Description

The Moku:Go Data Logger enables you to log data up to 1 MSa/s directly to its internal memory. The versatile front ends allow the user to select between AC / DC couplings, and 10 V_{pp} or 50 V_{pp} input ranges based on the experiment. It also provides user-configurable sampling rate along with duration and delay start options. Data saved to the Moku:Go internal memory can be uploaded to cloud or computers for analysis once the measurement is complete.



Features

- 8 GB of internal storage
- Log voltage data on two independent channels directly to the device
- Built-in two-channel 20 MHz waveform generator³
- Easily download log files to your computer for analysis. Built-in conversion tool to convert the binary data to .csv, .mat, HDF5, or NumPy format
- Schedule your log to start on a delay of up to 10 days
- Triggered start acquisition through a trigger signal from the analog input ports

³ See [Moku:Go Waveform Generator](#) for specifications on integrated waveform generators



Specifications

Logging

Acquisition

File formats	Binary: records data using a proprietary LI format for high-speed data logging. Can be converted to .csv, .txt, .mat, .npy, and HDF5.
Export modes	Dropbox, email, and iCloud, My Files
Maximum sampling rate	1 MSa/s with 1 channel enabled 500 kSa/s with 2 channels enabled
Minimum sampling rate	10 Sa/s
Maximum logging duration	10,000 hours
Delayed log start time	Up to 240 hours
Acquisition mode	Normal: Direct digitization at the acquisition rate Precision mode: Down sampling from maximum sampling rate by averaging Peak detect: Similar to Precision mode, except the highest and lowest samples are logged



Moku:Go Digital Filter Box

Description

With the Moku:Go Digital Filter Box, you can interactively design and generate different types of infinite impulse response filters with output sampling rates of 61.035 kHz, 488.28 kHz, and 3.9063 MHz. Select between lowpass, highpass, bandpass, and bandstop filter shapes with eight fully configurable types including Butterworth, Chebyshev, and Elliptic.

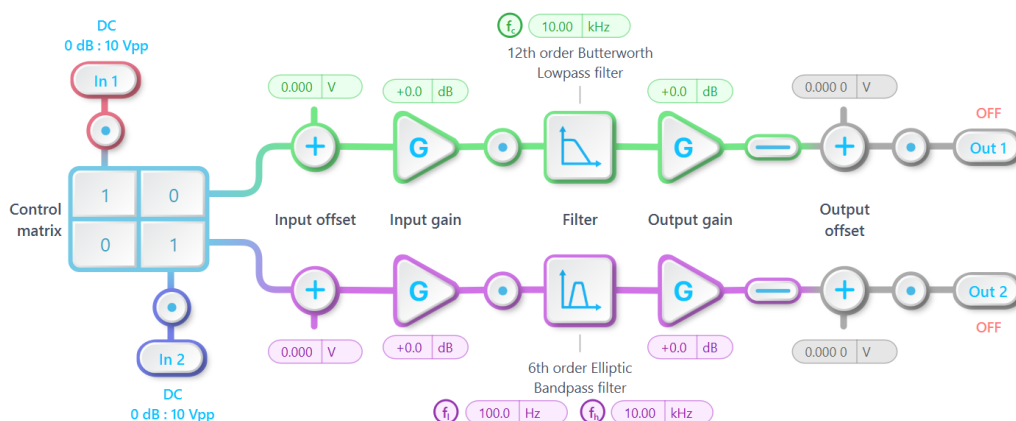

Features

- Design IIR filters using an interactive Bode plot
- Observe and log signals at different stages in the digital signal processing chain using probe points⁴
- View the magnitude and phase of the frequency response of your filter
- Filter up to two channels of data simultaneously with the ability to mix input signals.
- Implement custom filters by uploading your own coefficients

⁴ See [Moku:Go Data Logger](#) or [Moku:Go Oscilloscope](#) for specifications on integrated instruments



Specifications

Inputs

Input characteristics

Channels	2
Input control matrix coefficients	-20 to +20
Input impedance	1 M Ω
Input coupling	AC / DC
Input attenuation	0 dB / 14 dB
Input voltage range	10 V _{pp} into 1 M Ω with 0 dB attenuation 50 V _{pp} into 1 M Ω with 14 dB attenuation

Filter characteristics

Pre-filter

Input offset range	± 2.5 V
Input offset resolution	1 mV
Input gain range	-40 dB to +40 dB
Input gain resolution	0.1 dB

Post-filter

Output offset range	± 5 V
Output offset resolution	100 μ V
Output gain range	-40 dB to +40 dB
Output gain resolution	0.1 dB

General filter characteristics

Filter shapes	Lowpass, Highpass, Bandpass, Bandstop, Custom
Sampling rates	61.035 kHz, 488.28 kHz, 3.9063 MHz
Frequency resolution	0.1 mHz
Filter types	Butterworth, Chebyshev I, Chebyshev II, Elliptic, Cascaded, Bessel, Gaussian, Legendre
Passband ripple ⁵	0.1 dB to 10 dB
Stopband attenuation ⁶	10 dB to 100 dB

⁵ Applies to Chebyshev I and Elliptical filter types.

⁶ Applies to Chebyshev II and Elliptical filter types.



Lowpass filter

Filter order	2, 4, 6, 8, 10, 12
Lowpass corner frequency	11.73 mHz to 27.47 kHz at 61.035 kHz 93.81 mHz to 219.7 kHz at 488.28 kHz 750.5 mHz to 1.758 MHz at 3.9063 MHz

Highpass filter

Filter order	2, 4, 6, 8, 10, 12
High-pass corner frequency	144.7 mHz to 27.47 kHz at 61.035 kHz 1.158 Hz to 219.7 kHz at 488.28 kHz 9.263 Hz to 1.758 MHz at 3.9063 MHz

Bandpass filter

Filter order	2, 4, 6
Low-corner frequency	610.4 mHz to 27.47 kHz at 61.035 kHz 4.883 Hz to 219.7 kHz at 488.28 kHz 39.06 Hz to 1.758 MHz at 3.9063 MHz
High-corner frequency	1.392 Hz to 27.47 kHz at 61.035 kHz 11.13 Hz to 219.7 kHz at 488.28 kHz 89.06 Hz to 1.758 MHz at 3.9063 MHz
Minimum bandwidth	780 mHz at 61.035 kHz sampling rate 6.3 Hz at 488.28 kHz sampling rate 50 Hz at 3.9063 MHz sampling

Bandstop filter

Filter order	2, 4, 6
Low-corner frequency	11.73 mHz to 27.47 kHz at 61.035 kHz 93.81 mHz to 219.7 kHz at 488.28 kHz 750.5 mHz to 1.758 MHz at 3.9063 MHz
High-corner frequency	793.0 mHz to 27.47 kHz at 61.035 kHz 6.344 Hz to 219.7 kHz at 488.28 kHz 50.75 Hz to 1.758 MHz at 3.9063 MHz
Minimum bandwidth	780 mHz at 61.035 kHz sampling rate 6.3 Hz at 488.28 kHz sampling rate 50 Hz at 3.9063 MHz sampling



Selecting the right IIR filter

Filter type

Butterworth	Butterworth filters have a maximally flat passband and a monotonic frequency response, making them a good all-around filter type suitable for most applications.
Chebyshev I	Chebyshev I filters have ripple in the passband but a sharper transition than Butterworth filters, making them useful for applications requiring aggressive stopband attenuation but can tolerate passband ripple between 0.1 dB and 10 dB.
Chebyshev II	Chebyshev II filters have ripple in the stopband but a sharper transition than Butterworth filters, making them useful in applications requiring flat passbands and aggressive stopband attenuation.
Elliptic	Elliptic (Cauer) filters have ripple in both the passband and stopband, but also have the sharpest possible transition. Elliptic filters are useful in applications requiring extremely aggressive stopband attenuation.
Cascaded	Cascaded first-order filters have zero overshoot in the time domain.
Bessel	Bessel filters have maximally flat group and phase delay in the passband, thus preserving the wave shape of passband signals.
Gaussian	Gaussian filters have the minimum possible group delay, a step response with no overshoot, and minimum rise and fall time.
Legendre	Legendre (Optimum L) filters have the sharpest possible transition while maintaining a monotonic frequency response.



Moku:Go FIR Filter Builder

Description

With the Moku:Go FIR Filter Builder, you can design and implement lowpass, highpass, bandpass, and bandstop finite impulse response (FIR) filters with up to 14,819 coefficients at a sampling rate of 61.04 kHz and a sampling rate up to 3.906 MHz. The Moku application allows you to fine tune your filter's response in the frequency and time domains to suit your specific application. Select between four frequency response shapes, four common impulse responses, an equation and custom filter response, and up to seven window functions.

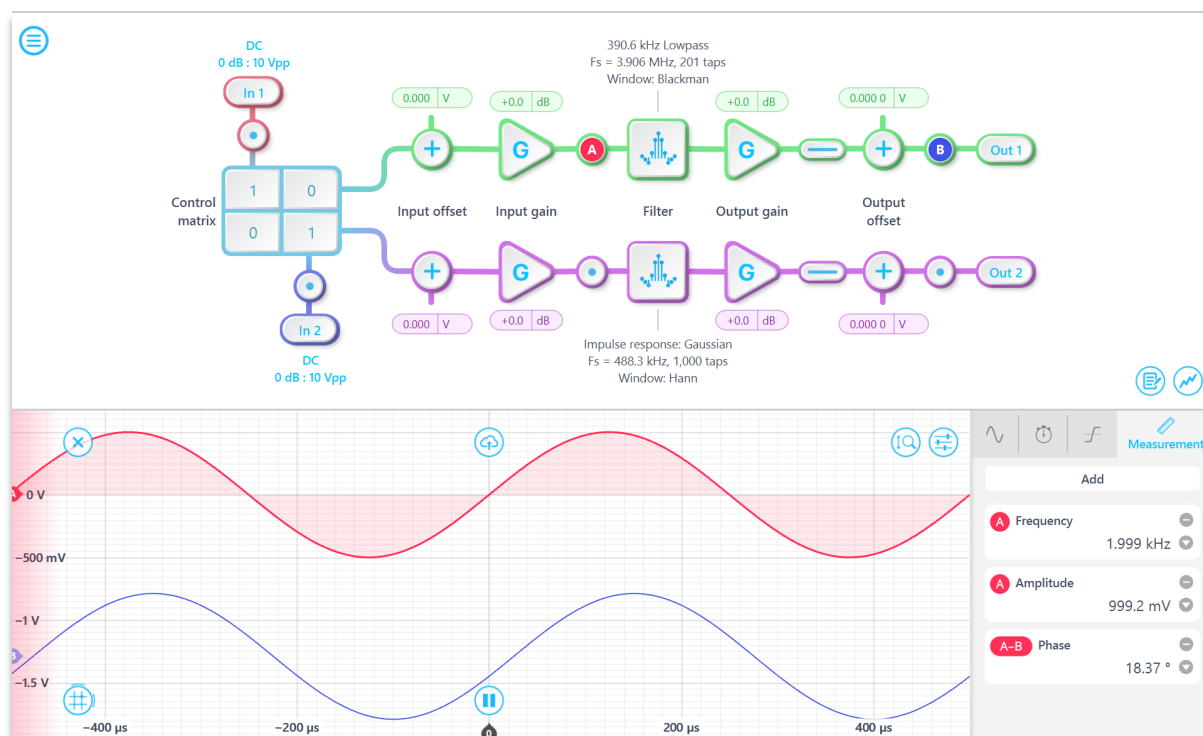

Features

- Design filters in the time domain or in the frequency domain using common impulse responses and window functions
- Upload your own filter coefficients, or define your own custom impulse response mathematically using an equation editor
- View your filter's transfer function, impulse and step response, or group and phase delay
- Observe and log signals at different stages in the digital signal processing chain using probe points⁷

⁷ See [Moku:Go Data Logger](#) or [Moku:Go Oscilloscope](#) for specifications on integrated instruments



Specifications

Inputs

Input characteristics

Channels	2
Input control matrix coefficients	-20 to +20
Input impedance	1 M Ω
Input coupling	AC / DC
Input attenuation	0 dB / 14 dB
Input voltage range	10 V _{pp} into 1 M Ω with 0 dB attenuation 50 V _{pp} into 1 M Ω with 14 dB attenuation

Filter characteristics

Pre-filter

Input offset range (DC)	± 2.5 V
Input offset resolution	1 mV
Input gain range	-40 dB to +40 dB
Input gain resolution	0.1 dB

Post-filter

Output offset range (DC)	± 5 V
Output offset resolution	100 μ V
Output gain range	-40 dB to +40 dB
Output gain resolution	0.1 dB

General filter characteristics

Sampling rates	30.52 kHz, 61.04 kHz, 122.1 kHz, 244.1 kHz, 488.3 kHz, 976.6 kHz, 1.953 MHz, 3.9063 MHz
Number of coefficients	2 to 232 @ 3.9063 MHz 2 to 464 @ 1.953 MHz 2 to 928 @ 976.6 kHz 2 to 1856 @ 488.3 kHz 2 to 3712 @ 244.1 kHz 2 to 7424 @ 122.1 kHz 2 to 14819 @ 61.04 kHz, 30.52 kHz
Design domains	Time (impulse response) Frequency (frequency response)



Filter design / configuration

Display options	Magnitude / Phase Impulse / Step Response Group / Phase Delay
Frequency response	Lowpass, highpass, bandpass, bandstop
Impulse response	Rectangular, Sinc, Triangular, Gaussian, Equation, Custom
Window	None, Bartlett, Hann, Hamming, Blackman, Nuttall, Tukey, Kaiser
Minimum filter cut-off frequency	Sampling rate / 10,000 <ul style="list-style-type: none">e.g., $f_{\min} = 12.21 \text{ Hz @ } 122.1 \text{ kHz}$
Maximum filter cut-off frequency	Sampling rate / 2 (approximately) <ul style="list-style-type: none">e.g., $f_{\max} = 59.81 \text{ kHz @ } 122.1 \text{ kHz}$



Moku:Go Frequency Response Analyzer

Description

The Moku:Go Frequency Response Analyzer enables you to measure the frequency response of a system in both magnitude and phase using a swept sine output from 10 mHz to 20 MHz. Select from between 32 and 8192 points per sweep and configure settling and averaging times to balance total sweep duration and signal-to-noise ratio.

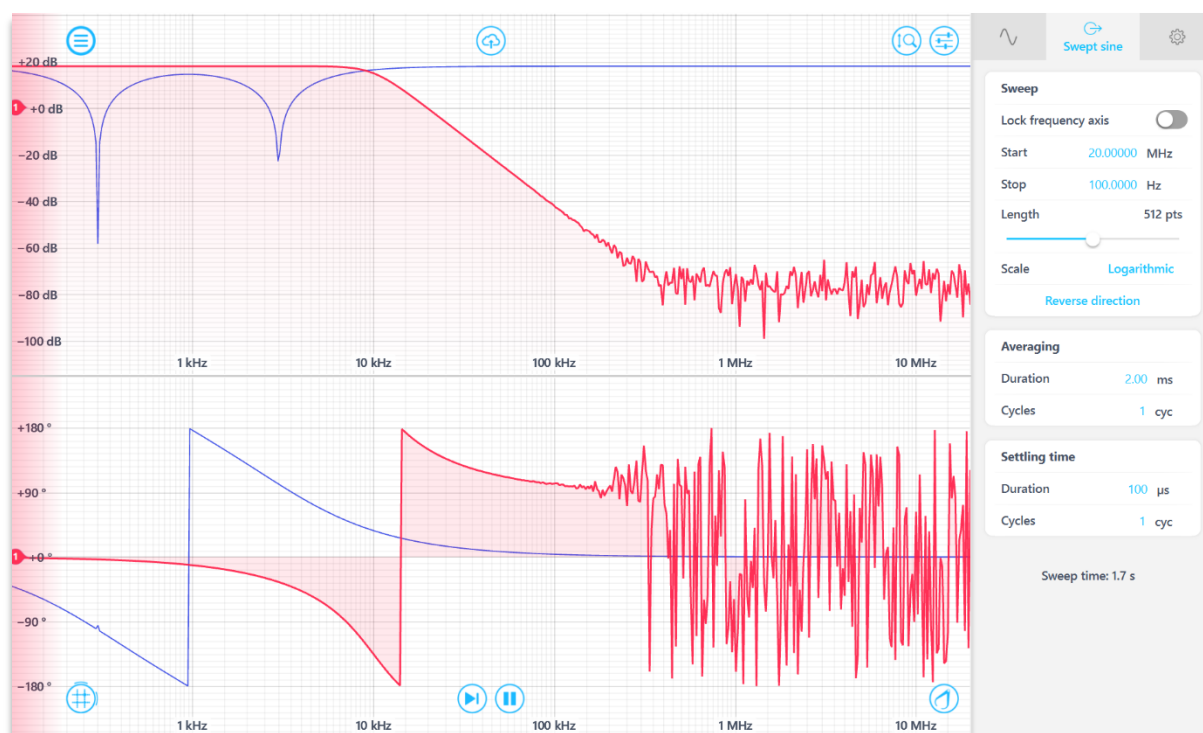

Features

- Measure the frequency response of a system from 10 mHz up to 20 MHz
- Select between linear or logarithmic sweep scales
- Probe two systems simultaneously or one system at two points
- Add, subtract, multiply, divide or use custom equations with response functions as they are acquired using the dedicated math channel
- Use cursors and markers to accurately measure features in both magnitude and phase
- Precisely adjust settling and averaging time to suit device under test
- Normalize your measurement to compare systems or compensate for delays



Specifications

Source

Source

Waveform	Sine
Frequency range	10 mHz to 20 MHz
Frequency resolution	1 μ Hz
Sweep type	Linear / Logarithmic
Sweep points	32, 64, 128, 256, 512, 1024, 2048, 4096, 8192
Output amplitude range	2 mV _{pp} to 10 V _{pp} into 1 M Ω
Output amplitude resolution	1 mV _{pp}
Offset range	\pm 4.999 V
Offset resolution	100 μ V
Source impedance	200 Ω

Measurement

Measurement characteristics

Settling time	Min.	Greater of 1 μ s or 1 cycle
	Max.	10.0 seconds
Averaging time	Min.	Greater of 1 μ s or 1 cycle
	Max.	10.0 seconds
Noise-floor	10 mHz to 100 kHz	-100 dB into 0 dB attenuation
		-80 dB into 14 dB attenuation
	100 kHz to 1 MHz	-125 dB into 0 dB attenuation
		-105 dB into 14 dB attenuation
1 MHz to 20 MHz	-130 dB into 0 dB attenuation	
	-110 dB into 14 dB attenuation	

Saving Data

Saving data

File formats	Binary: records data using a proprietary LI format for high-speed data logging. Can be converted to .csv, .txt, .mat, .npy, or HDF5
Export modes	Dropbox, email, and iCloud, My Files
Export types	Traces: saves the number of traces specified in the sweep settings to the specified file format
	Screenshot: saves the app window as a screenshot to PNG or JPG
	Settings: Save the current instrument settings to a text file



Moku:Go Laser Lock Box

Description

Moku:Go Laser Lock Box enables you to lock a laser's frequency to a reference cavity or atomic transition using high-performance modulation locking techniques. The Laser Lock Box includes a "Lock Assist" feature, enabling you to quickly lock to any zero-crossing on the demodulated error signal. The Lock Assist can also be customized to toggle modulation and scan signals, as well as configure the PID controller transfer function.

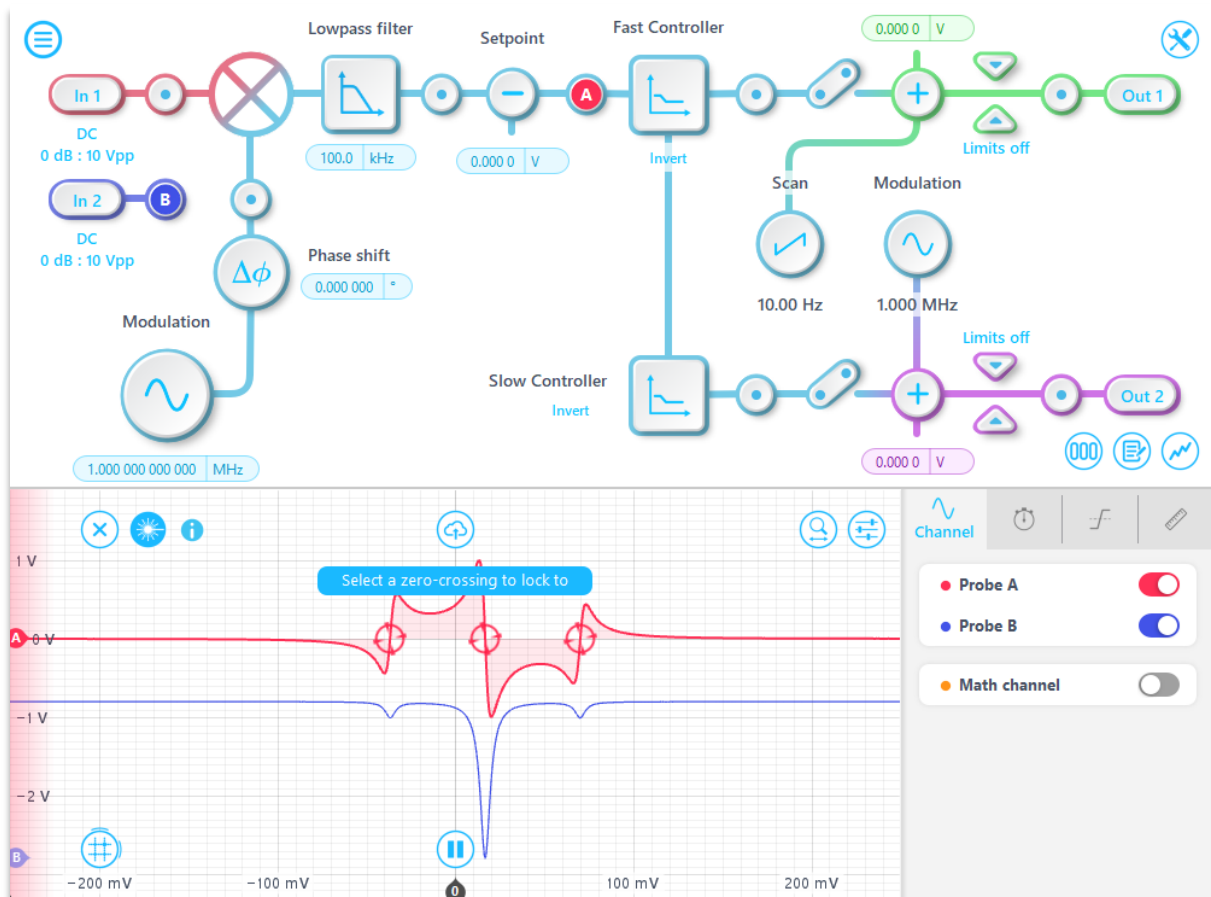

Features

- Generate modulation signals at up to 20 MHz
- Demodulate signals with an internal local oscillator, or external oscillator at the fundamental or up to the 250th harmonic
- Scan resonances with sawtooth or triangle waveforms at up to 10 MHz



- Observe and log signals at different stages in the digital signal processing chain using probe points⁸
- Quickly lock to any zero-crossing in the error signal using the “Lock Assist” feature
- Filter demodulated signals with up to fourth order infinite impulse response filters
- Individually configure high- and low-bandwidth PID controllers for fast and slow feedback

Specifications

Signal input

Signal input

Input coupling	AC / DC
Input impedance	1 M Ω
Frequency range	DC to 30 MHz
Input attenuation	-14 dB / 0 dB
Input range	50 V _{pp} with -14 dB input gain 10 V _{pp} with 0 dB input gain
Input noise	160 nV/ $\sqrt{\text{Hz}}$ above 220 kHz at 10 V _{pp} input range

Internal demodulation local oscillator

Internal reference waveform

Waveform	Sine
Frequency range	1 mHz to 30 MHz
Frequency resolution	1 μ Hz
Phase offset range	0 to 360°
Phase offset resolution	0.000 001°
Output impedance	200 Ω

External demodulation reference

Demodulation reference input

Input coupling	AC / DC
Input impedance	1 M Ω
Frequency range	DC to 30 MHz
Input attenuation	0 dB / 14 dB
External reference modes	Internal reference oscillator, external direct, external with phase-locked loop External with phase-locked loop can multiply up to 250 th harmonic or divide down to 1/8 th of fundamental

⁸ See [Moku:Go Data Logger](#) or [Moku:Go Oscilloscope](#) for specifications on integrated instruments



Phase-locked loop

PLL frequency range	10 Hz to 30 MHz
PLL tracking bandwidth	1Hz, 10Hz, 100Hz, 1kHz, 10kHz, 100kHz
Phase offset range	0 to 360°
Phase offset resolution	0.000 001°
Orthogonality	90° ± 0.000,002°
PLL multiplier	1/8 th to 250x of the fundamental

Filter

Filter

Filter architecture	Infinite Impulse Response (IIR)
Filter shape	Lowpass, Bandstop, or Custom
Sampling rate	7.8125 MHz
Filter types	Butterworth, Chebyshev I, Chebyshev II, Elliptic, Cascaded, Bessel, Gaussian, Legendre
Passband ripple ⁹	0.1 dB to 10 dB
Stopband attenuation ¹⁰	10 dB to 100 dB

Lowpass filter

Min. corner frequency	260.1 Hz
Max. corner frequency	3.516 MHz
Filter order	2, 4

Bandstop filter

Min. low corner frequency	260.1 Hz
Max low corner frequency	3.516 MHz
Min high corner frequency	360.1 Hz
Max high corner frequency	3.516 MHz
Minimum band width	100 Hz
Filter order	2

Modulation oscillator

Modulation waveform

Waveform	Sine
----------	------

⁹ Applies to Chebyshev I and Elliptical filter types.

¹⁰ Applies to Chebyshev II and Elliptical filter types.



Modulation waveform

Frequency range	1 mHz to 20 MHz
Frequency resolution	1 μ Hz
Amplitude range (AC)	2 mV _{pp} to 10 V _{pp} into 1 M Ω
Amplitude resolution	1 mV _{pp}
Offset range (DC)	± 5 V
Offset resolution	100 μ V
Output limit (AC + DC)	10 V _{pp} into 1 M Ω
Output impedance	200 Ω
Can be phase-locked to demodulation local oscillator?	Yes

Scan waveform

Scanning waveform

Waveform	Positive ramp, Negative ramp, Triangle
Frequency range	1 mHz to 10 MHz
Frequency resolution	1 μ Hz
Amplitude range (AC)	2 mV _{pp} to 10 V _{pp} into 1 M Ω
Amplitude resolution	1 mV _{pp}

PID Controllers

Set point

Set point range	-2.5 V to +2.5 V
Set point resolution	100 μ V

Fast controller

Sampling rate	7.8125 MHz
Proportional gain	± 60 dB
Integrator crossover frequency	312.5 mHz to 31.25 kHz (single integrator) 312.5 mHz to single integrator crossover frequency (double integrator)
Int. saturation crossover frequency	312.5 mHz to single integrator crossover frequency
Integrator gain range	Proportional gain to +80 dB
Differentiator crossover frequency	3.125 Hz to 312.5 kHz
Diff. saturation crossover frequency	Differentiator crossover frequency to 312.5 kHz
Differentiator gain range	Proportional gain to +80 dB



Slow controller

Sampling rate	12.2 kHz
Proportional gain	± 60 dB
Integrator crossover frequency	4.883 mHz to 488.3 Hz
Int. saturation crossover frequency	4.883 mHz to integrator crossover frequency
Integrator gain range	Proportional gain to +80 dB
Differentiator crossover frequency	48.83 mHz to 4.883 kHz
Diff. saturation crossover frequency	Differentiator crossover frequency to 4.883 kHz
Differentiator gain range	Proportional gain to +80 dB



Moku:Go Lock-In Amplifier

Description

Moku:Go Lock-in Amplifier supports dual-phase demodulation (XY/R θ) from 1 mHz to 30 MHz. It features an integrated 2-channel oscilloscope and data logger, enabling you to observe signals at up to 125 MSa/s and log data at up to 1 MSa/s. You can also place a PID controller after the demodulation stage for phase-locked loop applications.

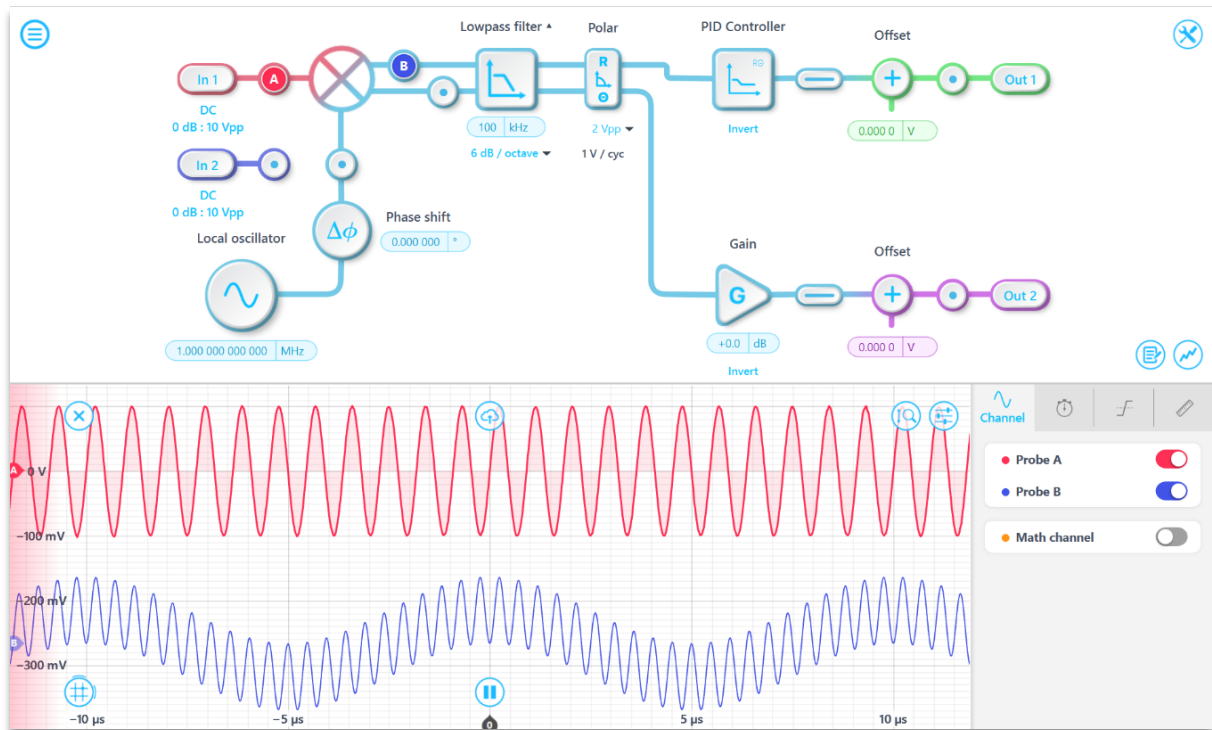

Features

- Measure signals obscured by noise with 80 dB dynamic reserve
- Block diagram view of the digital signal processing chain
- Observe and log signals at different stages in the digital signal processing chain using probe points¹¹
- Demodulate signals with an internal local oscillator, or external local oscillator at the fundamental, sub-harmonics, or up to 250th harmonic
- Toggle between rectangular (X/Y mode) or polar coordinates (R/ θ mode)

¹¹ See [Moku:Go Data Logger](#) or [Moku:Go Oscilloscope](#) for specifications on integrated instruments



Specifications

Signal channel

Signal input

Input coupling	AC / DC
Input impedance	1 M Ω
Frequency range	DC to 30 MHz
Input attenuation	0 dB / 14 dB
Input range	10 V _{pp} with 0 dB input attenuation 50 V _{pp} with 14 dB input attenuation
Input noise	160 nV/ $\sqrt{\text{Hz}}$ above 220 kHz at 10 V _{pp} input range

External reference

Reference input

Input coupling	AC / DC
Input impedance	1 M Ω
Frequency range	DC to 30 MHz
Input attenuation	0 dB / 14 dB
External reference modes	Direct, phase-locked
Direct demodulation	$X = R\cos\theta$

Phase-locked loop

PLL frequency range	10 Hz to 30 MHz
PLL tracking bandwidth	100 kHz, 10 kHz, 1 kHz, 100 Hz, 10 Hz, 1 Hz
Phase range	0 to 360°
Phase resolution	0.000 001°
Demodulation	XY / R θ
PLL multiplier	1/8 th to 250x of the fundamental

Internal reference

Internal reference waveforms

Waveform	Sine
Frequency range	1 mHz to 30 MHz
Frequency resolution	1 μ Hz
Phase range	0 to 360°
Phase resolution	0.000 001°
Demodulation	XY / R θ



Internal reference auxiliary output

Amplitude range (AC)	2 mV _{pp} to 10 V _{pp} into 1 MΩ
Amplitude resolution	1 mV _{pp}
Offset range (DC)	±5 V into 1 MΩ
Offset resolution	100 μV
Output limit (AC + DC)	10 V _{pp} into 1 MΩ
Output impedance	200 Ω

Demodulator

Demodulator characteristics

Sources	Internal reference oscillator, external direct, external with phase-locked loop
Types	Internal: XY / Rθ External direct: $X = R\cos\theta$ External with PLL: XY / Rθ
Filter mode	Lowpass filter
Filter cutoff frequency (-3dB)	100 mHz to 1.24 MHz
Filter time constant	128 ns to 2.15 s
Filter slope	6, 12, 18, 24 dB per octave
Dynamic reserve	> 100 dB

Signal output

Output characteristics

Modes	XY (cartesian mode), Rθ (polar mode), Auxiliary Oscillator, Local Oscillator
Number of output channels	2
Channel 1 output	X/R
Channel 2 output	Y/θ, auxiliary oscillator, local oscillator, or phase-locked to external reference signal
Output gain mode	Direct, PID ¹²
Gain range (direct)	-80 dB to 160 dB
Phase scale (Rθ mode)	1 V/cycle
Output voltage range	10 V _{pp} into 1 MΩ
Output impedance	200 Ω
D/A conversion	12-bits, 125 MSa/s, 20 MHz analog bandwidth

¹² Only one output may have a PID controller enabled at a time.



PID controller

Controller bandwidth	DC to 3.5 MHz
Phase delay	< 30° at 20 kHz
Proportional gain	± 120 dB (XY mode), ± 60 dB (Rθ mode)
Integrator crossover frequency	312.5 mHz to 31.25 kHz
Int. saturation crossover frequency	312.5 mHz to integrator crossover frequency
Integrator saturation gain range	Proportional gain to +120 dB (XY mode), +60 dB (Rθ mode)
Differentiator crossover frequency	3.125 Hz to 312.5 kHz
Diff. saturation crossover frequency	Differentiator crossover frequency to 312.5 kHz
Differentiator saturation gain range	Proportional gain to +120 dB (XY mode), +80 dB (Rθ mode)



Moku:Go Logic Analyzer

Description

Moku:Go Logic Analyzer / Pattern Generator is equipped with 16 bidirectional digital I/O with sampling rates up to 125 MSa/s. It supports 3.3 V logic levels (5V tolerant) and 262k × 16 input sample depth. Measurements are readily available through the interface. Data, screenshots can be captured and uploaded to the computer.

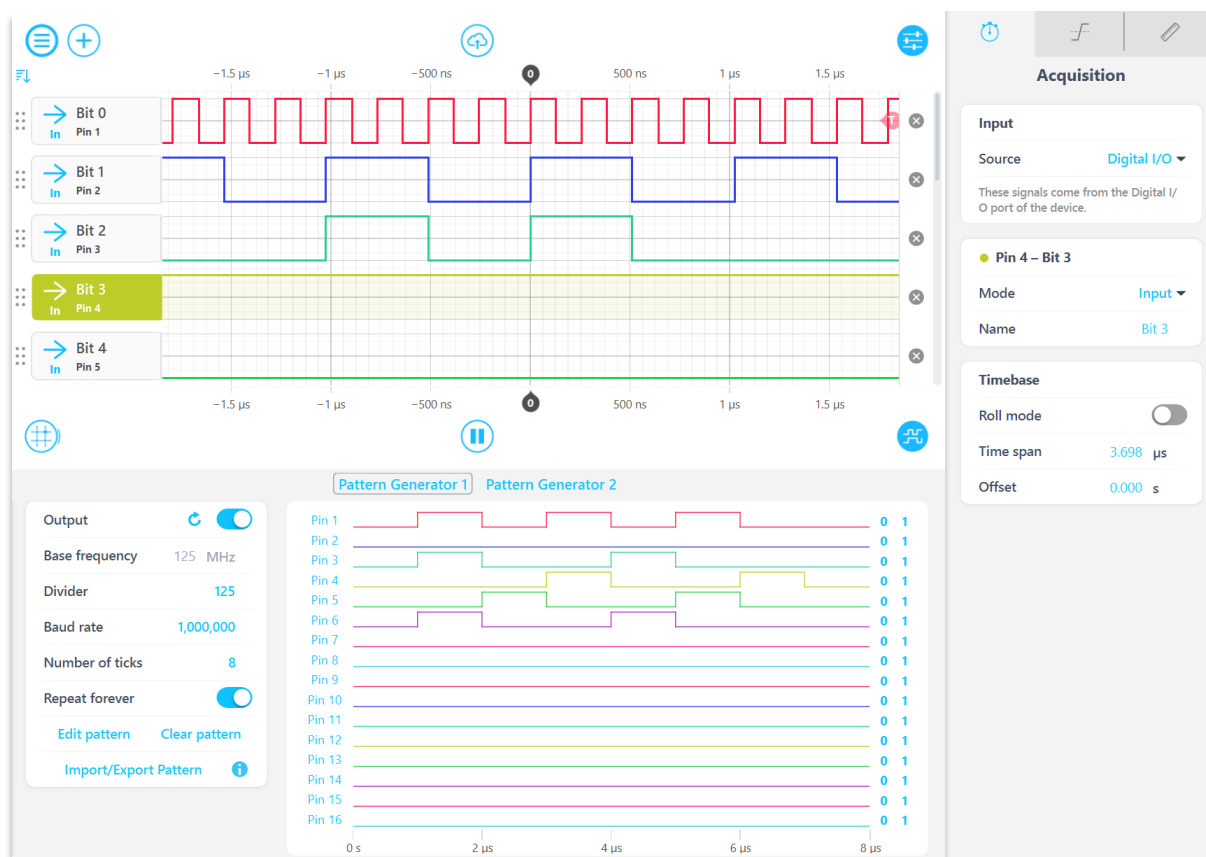

Features

- 16 channel bidirectional digital I/O with sampling rates up to 125 MSa/s.
- Support 3.3 V logic level, with 5 V tolerance for the inputs.
- 262k × 16 points input memory depth, 32,764 × 16 points output memory depth.
- Decode up to two protocols at a time, including UART, SPI, I²C, I²S, CAN, and Parallel bus.
- Powerful, intuitive graphical user interface with Python, LabVIEW, and MATLAB API support.



Specifications

Digital I/O

Interface

Total number of header pins	20
Number of bidirectional I/O	16
Number of ground pins	2
Power rails	3.3 V and 5 V

Input

Input logic level	3.3 V, 5 V tolerant
Input impedance	> 10 M Ω , < 4 pF

Output

Output logic level	3.3 V
Output impedance	400 Ω , < 4 pF

Horizontal characteristics

Acquisition

Sampling rate	125 MSa/s
Memory depth	262k points per channel
Maximum clock signal frequency	62.5 MHz

Generation

Sampling rate	125 MSa/s
Memory depth	32,764 points per channel
Maximum clock signal frequency	62.5 MHz
Clock divider	1 to 1,000,000

Trigger

Trigger

Trigger modes	Auto:	Triggers automatically after timeout (1 second if previously triggered, 0.05 seconds otherwise)
	Normal:	Triggers only on trigger event
	Single:	Triggers once on a trigger event. Press the 'play' button to re-trigger
Trigger sources	An input or output pin	



Trigger

Nth event	Trigger on the 1 st to 65,535 th event
Holdoff	up to 10 seconds
Trigger types	Edge or Combination ¹³

Measurements

Measurements

Time measurements	Frequency, phase, period, duty cycle, positive pulse width, negative pulse width
Math	AND, OR, XOR, NAND, NOR, XNOR

Protocol decoder

UART

Data width	5 bits to 9 bits
Stop width	1 bit to 2 bits
Parity	None, Even, Odd
Baud rate	1 to 2,000,000
Bit order	LSB first, MSB first
Max standard baud rate	921,600

SPI

CLK	Serial clock bit
CS	Chip select bit
DATA	Serial data bit
Data width	5 bits to 9 bits
Bit order	LSB first, MSB first
Clock polarity	Idle low, Idle high
Clock phase	Sample on leading, Sample on trailing
Max decoder frequency	5 MHz

I²C

Address size	7 bits
--------------	--------

¹³ The triggering signal in Combination mode is determined by the logical operations performed on the edges or levels status of the pins.



I²C

SCL ¹⁴	Serial clock bit
SDA	Serial data bit
Max decoder frequency	> 1 MHz

I²S

SCK	Serial Clock bit
WS	Word Select bit
SD	Serial Data bit
Bit order	LSB first, MSB first
Offset	Number of clock cycle to wait after WS transition before data transmission starts
Data width	2 to 32
Max decoder frequency	2 MHz

CAN

RX	Any of Pin 1 – Pin 16
Baud rate	Up to 1 Mbps
Data bit order	MSB or LSB first

Parallel bus

Sample mode	Rising edge, falling edge, both edges
Data width	1-12 bits
CLK	Any input bit

Saving data

Exporting data

File formats	Binary: records data using a proprietary LI format for high-speed data logging. Can be converted to .csv, .txt, .mat, .npy, and HDF5.
Export modes	Dropbox, email, iCloud, and My Files

Export types

Traces	Save 1024 points of data from each visible input pin in the current time span
--------	---

¹⁴ Some protocols like I²C and I²S require the user to select a pin for their input data to the protocol decoder. Ensure the pins labelled on the DIO cable match the pins you set for your input data.



Export types

Protocol data	Save protocol decoder states and data as comma-separated values
Screenshot	Save the app window as a PNG or JPG
Settings	Save the current instruments settings to a text file
Measurements	Save all active measurements as comma-separated values
High-res data	Save up to 262 kpts per active bit



Moku:Go Oscilloscope

Description

The Moku:Go Oscilloscope features two input channels with sampling rates up to 125 MSa/s and 30 MHz analog bandwidth. Both channels support user-selectable AC / DC couplings, and 10 V_{pp} or 50 V_{pp} input ranges. The built-in two-channel waveform generator is capable of producing waveforms with a maximum bandwidth of 20 MHz.

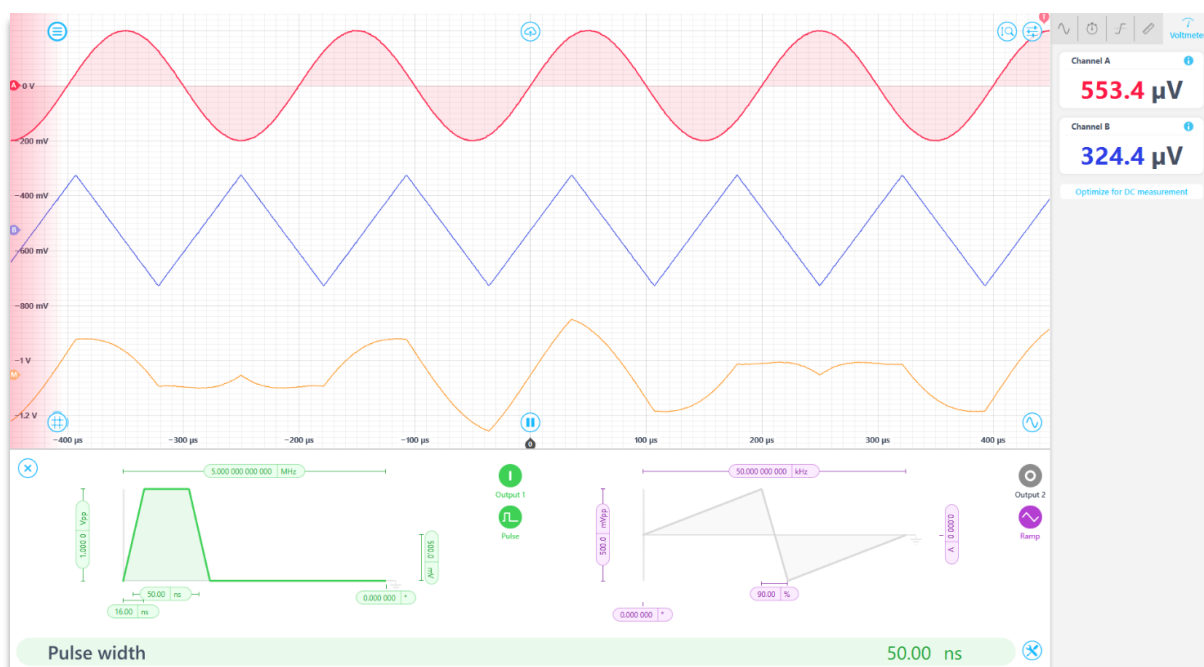

Features

- Two analog inputs with 125 MSa/s sampling rate and 30 MHz bandwidth.
- Intuitive user interface on Windows or Mac.
- Onboard signal analysis measurements.
- Math channel with support for arbitrary functions.
- Integrated, high-speed, 2-channel waveform generator with maximum frequency up to 20 MHz.



Specifications

Vertical characteristics

Voltage

Channels	2
Input coupling	AC / DC
Input impedance	1 M Ω
Input bandwidth (-3 dB)	> 30 MHz
Input voltage range	10 V _{pp} or 50 V _{pp}
Input voltage noise	160 nV/ $\sqrt{\text{Hz}}$ above 220 kHz at 10 V _{pp} input range
Vertical resolution ¹⁵	12 bits at 125 MSa/s (ADC resolution) 13 bits at 31.25 MSa/s 22 bits at 250 Sa/s
Channel-to-channel isolation	> 40 dB

Horizontal characteristics

Time

Time mode	Normal, Roll
Horizontal range	5 ns/div to 20 s/div
Delay range	Pre-trigger: 16 kSamples Post-trigger: 2 ³⁰ samples

Acquisition

Acquisition mode	Normal, Precision, Peak Detect, Deep Memory ¹⁶
Maximum sampling rate	125 MSa/s
Memory depth	4.2 MSa per channel (Deep memory mode)
Averaging (linear)	Off, 2 to 100 waveforms
Interpolation	Linear, SinX/X, Gaussian

¹⁵ Higher number of bits above the physical ADC specification is only available in precision mode.

¹⁶ See the [Moku:Go User Manual](#) for more information on how Acquisition modes are implemented.



Trigger

Trigger

Trigger modes	Auto:	Triggers automatically after timeout (1 second if previously triggered, 0.05 seconds otherwise)
	Normal:	Triggers only on trigger event
	Single:	Triggers once on a trigger event
Trigger sources	Input 1, Input 2, Output 1, Output 2	
Nth event	Trigger on the 1 st to 65,535 th event	
Holdoff	up to 10 seconds	
Trigger types	Edge:	Rising edge, falling edge, both edges
	Pulse:	Positive / negative polarity <ul style="list-style-type: none">10.0 seconds > pulse width > 32.0 nanoseconds

Trigger sensitivity

Sensitivity modes	Auto:	Automatically configures trigger sensitivity based on horizontal and vertical scales Select <i>Noise Reject</i> or high-frequency <i>HF Reject</i> options
	Manual:	Manually configure trigger sensitivity
Manual modes	Relative, Absolute	
Hysteresis	Relative:	0.01 div to 5.00 div
	Absolute:	100 μ V to 1.00 V

Measurements

Measurements

Time measurements	Frequency, phase, period, duty cycle, positive pulse width, negative pulse width, rise time, fall time, rise rate, fall rate
Amplitude measurements	Peak-to-peak, amplitude, maximum, minimum, mean, cycle mean, RMS, cycle RMS, standard deviation, high-level, low-level, overshoot, undershoot, fringe vis.
Math	Add, subtract, multiply, divide, XY mode, integrate, differentiate, FFT, min hold, max hold, arbitrary equation mode (using equation editor)

Cursors

Maximum voltage cursors	Unlimited
Maximum time cursors	Unlimited
Voltage cursor options	Manual, track mean, track maximum, track minimum, maximum hold, minimum hold
User defined reference	A single cursor can be set as a reference for differential measurements using all other active cursors



Saving data

Exporting data

File formats	Binary: records data using a proprietary LI format for high-speed data logging. Can be converted to .csv, .txt, .mat, .npy, and HDF5.
--------------	---

Export modes	Dropbox, email, iCloud, and My Files
--------------	--------------------------------------

Export types

Traces	Save 1024 points of data from each visible input pin in the current time span
--------	---

Screenshot	Save the app window as a PNG or JPG
------------	-------------------------------------

Settings	Save the current instruments settings to a text file
----------	--

Measurements	Save all active measurements as comma-separated values
--------------	--

High-res data	Save up to 4.2 Mpts per active channel ¹⁷
---------------	--

¹⁷ Deep memory mode must be enabled before exporting high-res data.



Moku:Go PID Controller

Description

Moku:Go PID Controller instrument features two fully configurable PID controllers with an open loop bandwidth of 3.53 MHz. This enables them to be used in various applications such as current or robotic arm control. The intuitive graphic user interface allows you to directly adjust the PID parameters on the Bode plot.

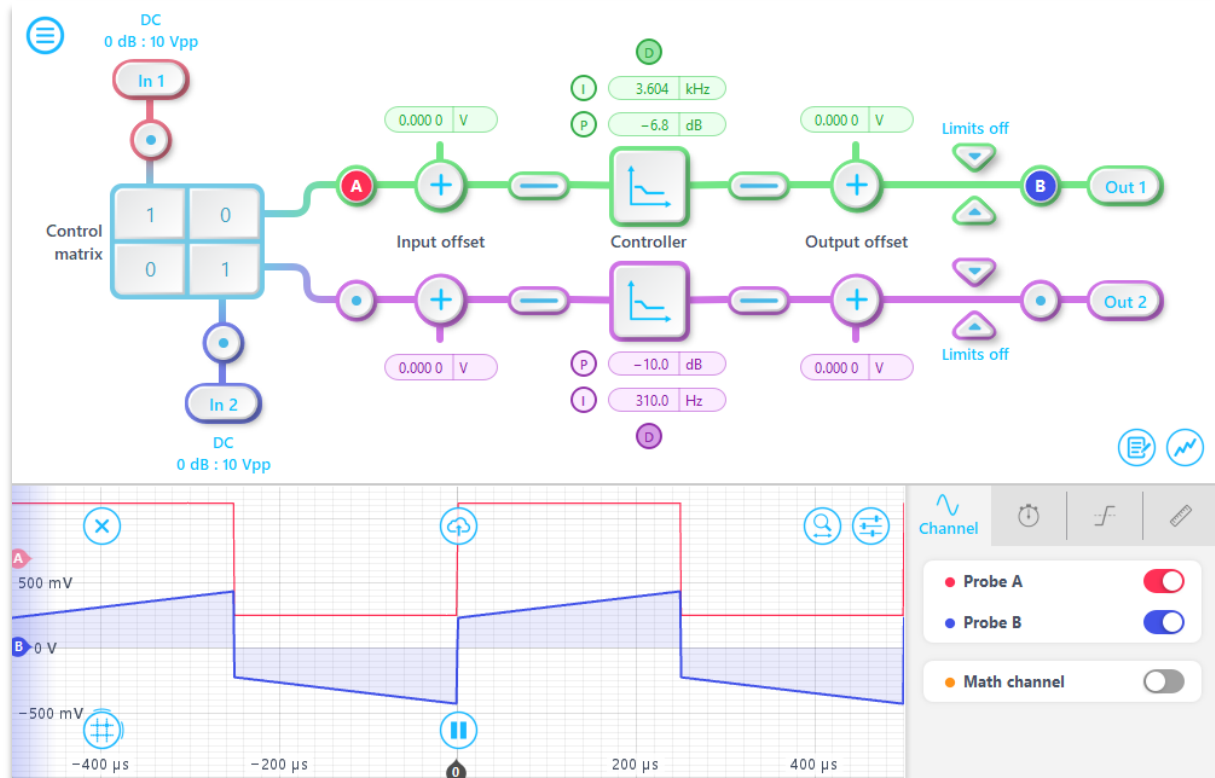

Features

- 2 input channels, 2 output channels, and 2 independent PID controllers with control matrix for optional linear combination of inputs.
- Design your control system's frequency response using the interactive Bode plot in real-time
- Block diagram view of the digital signal processing chain with built-in probe points for viewing and logging data.¹⁸
- Advanced multi-section PID builder with single or double integrators and differentiators with low- and high-frequency gain saturation

¹⁸ See [Moku:Go Oscilloscope](#) and [Moku:Go Data Logger](#) for integrated instrument specifications



Specifications

Inputs

Input characteristics

Channels	2
Input control matrix coefficients (linear gain)	-20 to +20
Input impedance	1 M Ω
Input coupling	AC / DC
Input range	10 V _{pp} or 50 V _{pp}

Controller

General characteristics

Gain profiles	Proportional (P), integral (I), differential (D), double-integral (I+), integral saturation (IS), differential saturation (DS)
Controller phase delay (P = 0 dB)	20 kHz with a phase delay of 30° 130 kHz with a phase delay of 180°
Open controller bandwidth (-3 dB)	3.5 MHz
Input offset range	± 2.5 V
Output offset range	± 5 V
Offset resolution	100 μ V
Voltage limiter range (High & Low)	-5 V to 5 V
Voltage limiter resolution	1 mV

Gain characteristics

Gain profiles	Proportional (P), integral (I), differential (D), double-integral (I+), integral saturation (IS), differential saturation (DS)
Proportional gain	± 60 dB
Integrator crossover frequency	312.5 mHz to 31.25 kHz (single integrator) 312.5 mHz to single integrator crossover frequency (double integrator)
Integrator saturation level	Between proportional gain and +60 dB The integrator saturation corner frequency cannot be lower than 312.5 mHz
Differentiator crossover frequency	3.125 Hz to 312.5 kHz
Differentiator saturation level	Between proportional gain and +60 dB The differentiator saturation corner frequency cannot be higher than 312.5 kHz



Moku:Go Phasemeter

Description

The Moku:Go Phasemeter measures phase (relative to a reference clock) of up to two input signals with better than 1 nanoradian precision from 1 kHz up to 30 MHz. Based on a digitally implemented phase-locked loop architecture, the Moku:Go Phasemeter provides exceptional dynamic range, zero deadtime, and measurement precision that exceeds the performance of conventional lock-in amplifiers and frequency counters.

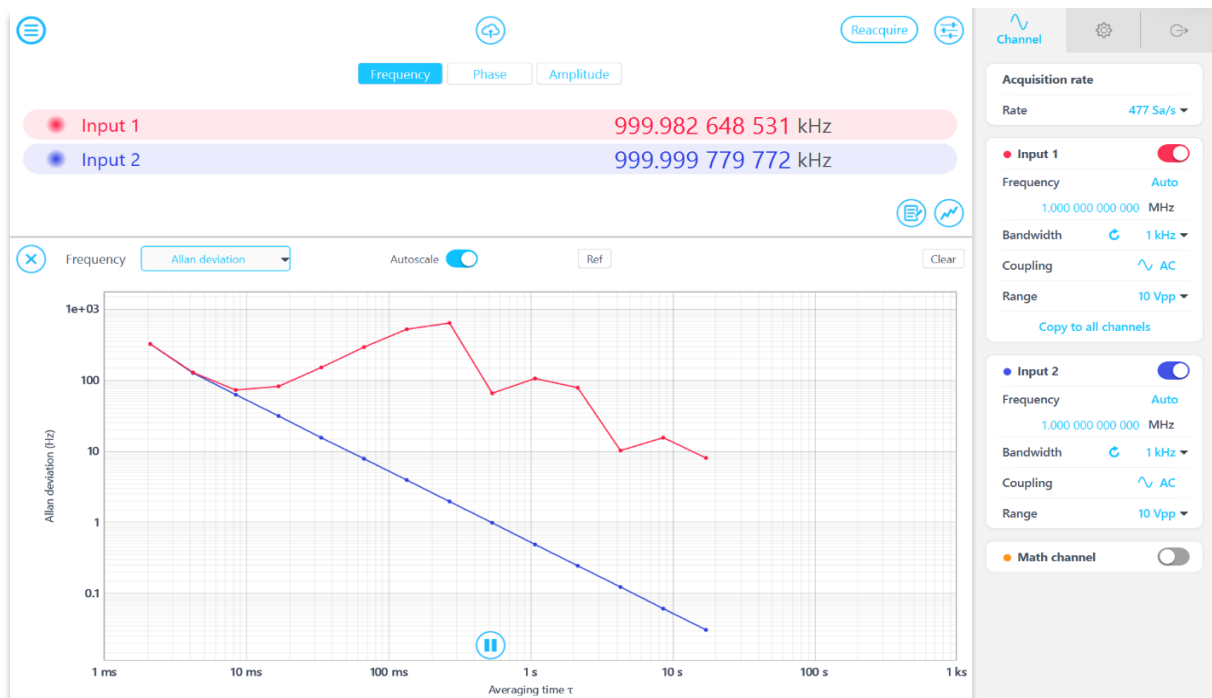

Features

- Two independent phasemeter channels that track and record phase, frequency, and amplitude.
- Phase-locked output option enables you to generate sine waves that are phase-locked to the inputs at the fundamental frequency, harmonics, or sub-harmonics.
- Output measured amplitude, phase, or frequency offset for closed-loop control systems, or stream to a computer using Moku APIs.
- Real-time spectral analysis to display and save power spectral densities, Allan deviation, and more.
- Phase-locked loop tracking bandwidths from 1 Hz to 100 kHz



Specifications

Inputs

Input characteristics

Input frequency range	1 kHz to 30 MHz
Input voltage range	10 V _{pp} into 1 MΩ with 0 dB attenuation 50 V _{pp} into 1 MΩ with 14 dB attenuation
Input impedance	1 MΩ
Input coupling	AC / DC

Measurement

Measurement characteristics

Phase error	2 μradian/√Hz @ 10 Hz
Phase precision	1 nradian
Frequency precision	1 μHz
Reference frequency resolution	10 μHz
Modes of operation	Auto-acquire Automatically determines input frequency for signals above 1 MHz Manual Initializes the phasemeter to a specific frequency
Tracking bandwidth	1 Hz / 10 Hz / 100 Hz / 1 kHz / 10 kHz / 100 kHz (user selectable)
Advanced option	Phase wrapping, auto-reset, and user-configurable output scaling

Data visualization

Visualizations	Timeseries, Power Spectral Density, Amplitude Spectral Density, Coherence, Rayleigh Spectrum, Allan Deviation
----------------	---

Synthesizer

Synthesizer¹⁹

Channels	2
Output impedance	200 Ω
Waveform shape	Sine
Output modes	Manual, phase-locked to input signal, with scaling to 250x harmonic or 1/8 th sub-harmonic
Sampling rate	125 MSa/s
Voltage range	5 V _{pp}

¹⁹ Where not stated, the Phasemeter synthesizer specifications match those of the [Waveform Generator](#) instrument.



Outputs

Phase, frequency offset or amplitude output

Channels	2
Modes of operation	Sine wave (option to phase-lock to the input signal) Drive measured signal phase, frequency offset, or amplitude with user-defined scaling and configurable DC offset

Saving data

Saving data

Logging rates	30 Sa/s, 119 Sa/s, 477 Sa/s, 1.9 kSa/s, 15.2 kSa/s, 122 kSa/s
File format	Binary: Records data using a proprietary LI format for high-speed data logging. Can be converted to .csv, .txt, .mat, .npy, and HDF5
Delayed log start time	Up to 240 hours
Log duration	Up to 10,000 hours



Moku:Go Spectrum Analyzer

Description

Moku:Go Spectrum Analyzer allows you to observe input signals in the frequency domain between DC and 30 MHz. The frequency down-conversion / FFT hybrid approach provides significant improvement in dynamic range and spectral resolution compared to an FFT-based spectral analysis. View two channels of data simultaneously with a resolution bandwidth as low as 108 mHz over a minimum span of 100 Hz. The Spectrum Analyzer also features two integrated waveform generators capable of producing sine waves at up to 20 MHz.

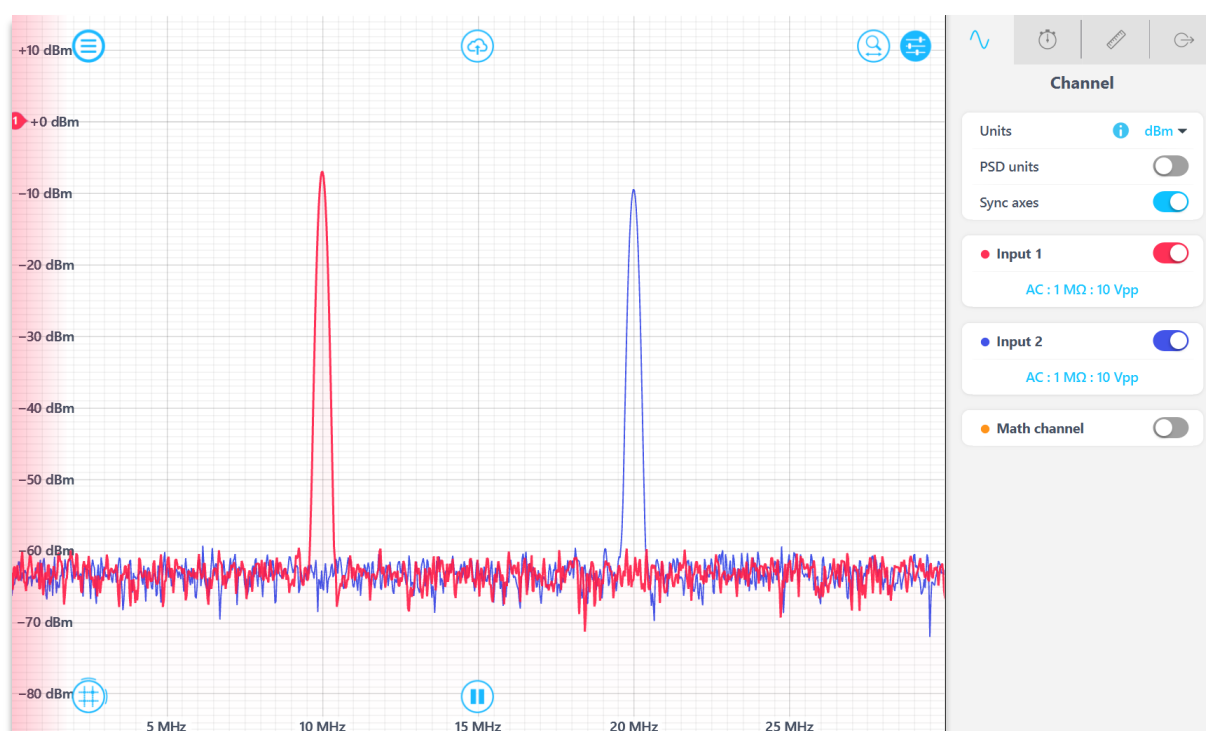

Features

- Generate two sine waves up to 20 MHz using the Moku:Go built-in analog outputs²⁰
- Quickly measure key metrics by dragging measurement cursors onto features of interest using the graphical interface
- View spectral data in units of Volts or dBm as either power or power spectral density
- Export data and instruments settings quickly with email and My Files integration²¹

²⁰ See [Moku:Go Waveform Generator](#) for waveform specifications. Only sine wave can be generated when using the Spectrum Analyzer.

²¹ See [Moku:Go Oscilloscope](#) for data export options.



Specifications

Frequency

Frequency

Range	DC to 30 MHz
Span	100 Hz to 30 MHz

Resolution bandwidth (RBW)

Modes	Auto	Automatically sets the RBW based on the current span and window function
	Manual	Allows the user to manually set the RBW within the limits tolerated by the span and window function
	Min	Sets the RBW at the minimum possible value for the current span and window function The minimum RBW is 108 mHz
Windows	Rectangular, Bartlett, Hamming, Hann, Blackman-Harris, Flat top, Nuttall, Gaussian, Kaiser	

Amplitude

Voltage

Channels	2
Input coupling	AC / DC
Input impedance	1 M Ω
Input range	10 Vpp or 50 Vpp
Input bandwidth (-3 dB)	> 30 MHz into 1 M Ω

Display

Scales	Volts, dBm
Display modes	Power, Power Spectral Density (PSD)
Video bandwidth (VBW)	100 mHz to 310 kHz depending on span
Averages	1 to 100
Math Channel modes	Add, Multiply, Min hold, Max hold
Measurements	Peak level, Peak frequency, Noise level, Peak SNR, Occupied BW



Moku:Go Time & Frequency Analyzer

Description

Moku:Go Time & Frequency Analyzer measures intervals between configurable start and stop events with sub-nanosecond precision. Select between continuous, windowed, or gated acquisition mode, compute histograms of interval duration losslessly and in real-time, and log high-resolution event timestamps to on-board storage. Output the measured interval count or current interval to analog output channels for active feedback control.

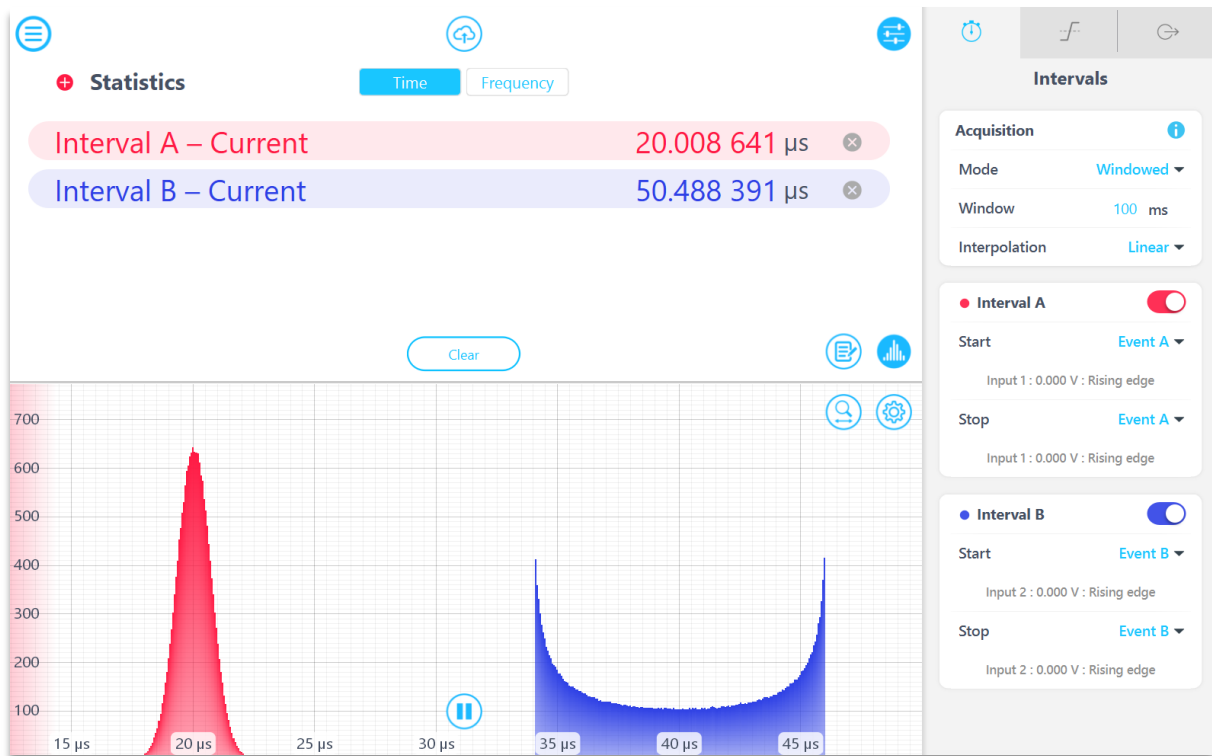

Features

- Jitter of < 50 ps for high timing resolution analysis
- Up to two independent event detectors with configurable thresholds on rising edge, falling edge, or both
- Lossless, real-time histograms with a minimum bin width of 7.8 ps
- Output interval count or current interval with adjustable scaling factor
- High resolution raw event timestamp logging to on-board storage for post processing
- Combine with any other instrument in Multi-instrument Mode for system level characterization and feedback control



Specifications

Events

Input characteristics

No. of independent analyzers	2
Source	Input 1, Input 2
Input Coupling	AC / DC
Input Impedance	1 M Ω
Input voltage range	10 V _{pp} , 50 V _{pp}
Frequency range	DC to 30 MHz
Max interval rate	15.625 MHz
Threshold	+/-5 V or +/-25 V
Edge	Rising, Falling, Both
Jitter	< 50 ps
Optimum edge time	60 ns*

*Edge times faster than the optimum edge time can lead to a large bias in the measurement. We recommend adding an analog filter with a 6 MHz bandwidth on the input.

Histogram

Bins	Up to 1024
Min bin width	7.8 ps

Acquisition

Acquisition mode	Windowed, Gated, Continuous
Window length	1 ms to 10 s
Gate source	Input 1, Input 2
Gate threshold	-5 V to 5 V
Interpolation	None, Linear

Intervals

Intervals

No. of independent analyzers	2
Start	Event A, Event B
Stop	Event A, Event B

Real-time statistics

Mean, Minimum, Maximum, Count



Signal output

Output characteristics

Number of output channels	2
Modes	Interval, Count
Zero point	0 s to 1 ks
Scaling (Interval)	1 mV/s to 100 MV/s
Scaling (Count)	10 nV/cnt to 1 V/cnt
Range	10 Vpp

Data logger

Rate	Up to 15.625 Mevnt/sec burst Up to 10 Mevnt/sec continuous
Available memory	8 GB
Start Mode	Immediate, Delayed
Duration	1 ms to 10,000 hours



Moku:Go Waveform Generator

Description

Moku:Go Waveform Generator enables you to generate two independent waveforms with a sampling rate of 125 MSa/s, and a maximum frequency of 20 MHz with an output voltage range up to 10 Vpp. Select between sine, square, ramp, pulsed, noise, or DC waveform shapes. Modulate the phase, frequency, or amplitude, or generate triggered bursts or sweeps from an internal or external source.

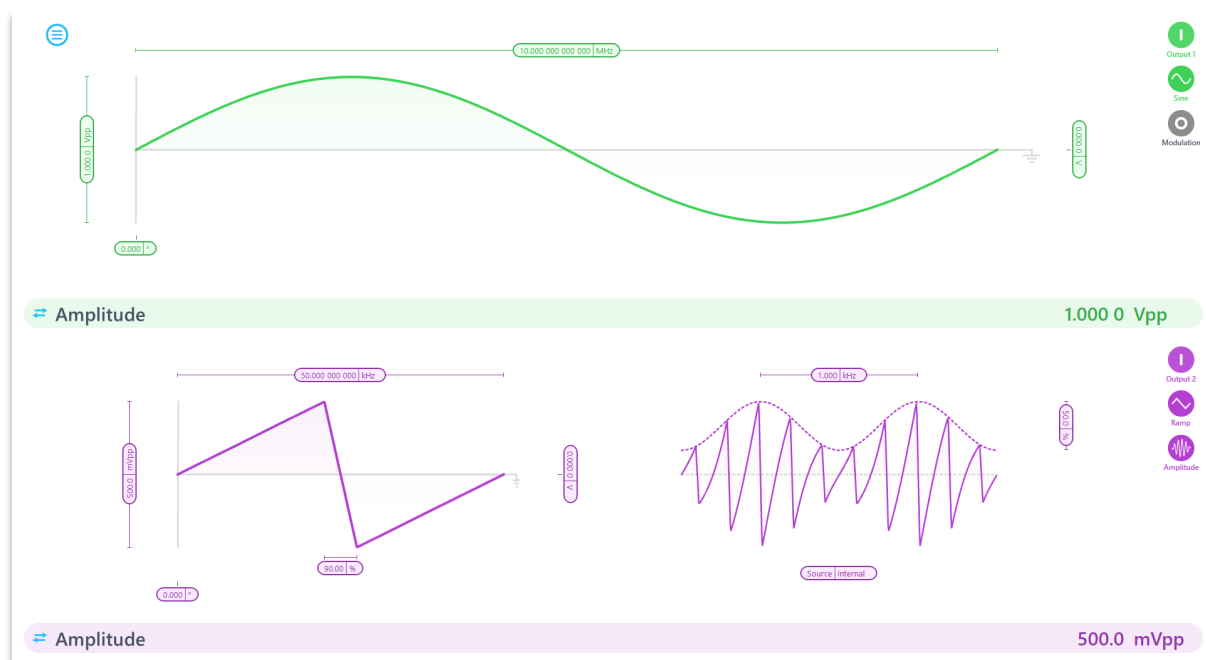

Features

- Generate 2 independent waveforms from DC to 20 MHz
- 6 built-in waveforms: sine, square, ramp, pulse, noise, and DC
- FM, AM, PM, and PWM modulation with internal waveform (cross-channel modulation) or external input
- Versatile trigger options: from input, or the other output channel



Specifications

Common characteristics

Overview

Channels	2
Bandwidth (-3 dB)	20 MHz
Sampling rate	125 MSa/s per channel
Output impedance	200 Ω
Waveforms	Sine, Square, Ramp, Pulse, Noise, DC

Amplitude

Range	2 mV _{pp} to 10 V _{pp} into 1 M Ω
Resolution	100 μ V

DC offset

Range	\pm 4.999 V into 1 M Ω
Resolution	100 μ V

Phase offset

Range	0° to 360°
Resolution	0.000 001°
Accuracy	\pm 0.000 001% of 360° range
Phase drift	0.000 5 deg/sec

Waveform characteristics

Sine

Frequency range	1 mHz to 20 MHz
Frequency resolution	1 μ Hz
Total harmonic distortion	< 0.5% (1.9 MHz, 5 harmonics)
SFDR	> 50 dBc

Square

Frequency range	1 mHz to 5 MHz
Frequency resolution	1 μ Hz
Edge time	16 ns into 50 Ω
Overshoot	< 1% into 1 M Ω



Ramp

Frequency range	1 mHz to 5 MHz
Frequency resolution	1 μ Hz
Symmetry ²²	8% to 92% at 5 MHz 0.8% to 99.2% at 500 kHz 0.01% to 99.99% at 5 kHz

Pulse

Frequency range	1 mHz to 5 MHz
Frequency resolution	1 μ Hz
Period range	1000 s to 200 ns
Pulse width	16 ns to (period - edge time)
Edge time	16 ns to pulse width
Edge time resolution	1 ns
Overshoot	< 1%

Modulation

Amplitude

Carrier waveforms	Sine, Square, Ramp, Pulse, Noise
Source	Ch1: Input 1, Input 2, Output 2, Internal Ch2: Input 1, Input 2, Output 1, Internal
Internal modulation	Sine
Frequency	1 mHz to 5 MHz
Amplitude modulation resolution	$\pm 0.1\%$ /V
Depth	0% to 100%

Frequency

Carrier waveforms	Sine, Square, Ramp, Pulse
Source	Ch1: Input 1, Input 2, Output 2, Internal Ch2: Input 1, Input 2, Output 1, Internal
Internal modulation	Sine
Frequency	1 mHz to 5 MHz
Frequency modulation resolution	± 1 mHz/V
Deviation (carrier + deviation)	DC to 20 MHz

²² Symmetry is limited by the minimum rise time of 16 ns and number of harmonics required to maintain a linearity of more than 99%.



Phase

Carrier waveforms	Sine, Square, Ramp, Pulse
Source	Ch1: Input 1, Input 2, Output 2, Internal Ch2: Input 1, Input 2, Output 1, Internal
Internal modulation	Sine
Frequency	±1 mHz to 5 MHz
Phase modulation resolution	0.001 °/V
Phase shift	0.0° to 3600.0°

Pulse Width

Carrier waveforms	Pulse
Source	Ch1: Input 1, Input 2, Output 2, Internal Ch2: Input 1, Input 2, Output 1, Internal
Internal modulation	Sine
Frequency	1 mHz to 5 MHz
Pulse width modulation resolution	±1 ns/V
Deviation	0 to pulse width (limited by pulse width period)

Burst

Modes of Operation	Start ²³ , N-Cycle, Gated
N-Cycle range	1 to 1,000,000
Trigger Sources	Ch1: Input 1, Input 2, Output 2, Internal Ch2: Input 1, Input 2, Output 1, Internal
Trigger Level	10 V _{pp} or 50 V _{pp}

Sweep

Sweep Frequency Start/End	Sine: 1 mHz to 20 MHz Square, Ramp, Pulse: 1 mHz to 5 MHz
Sweep Time	1 ms to 1 ks
Trigger Sources	Ch1: Input 1, Input 2, Output 2, Internal Ch2: Input 1, Input 2, Output 1, Internal
Trigger Level	±5 V or ±25 V

²³ Start burst mode cannot be internally triggered.



Moku:Go Multi-Instrument Mode

Description

Moku:Go Multi-Instrument Mode enables you to deploy up to two instruments and operate them simultaneously. These instruments can exchange high-speed, low latency signals between themselves in the digital domain at 2 Gb/s. Source signals from the real world via the ADCs and drive signals to the real world via the high-speed digital-to-analog converters. Connect instrument slots to build customized signal processing chains or drop a custom configuration in one slot with Moku Cloud Compile.

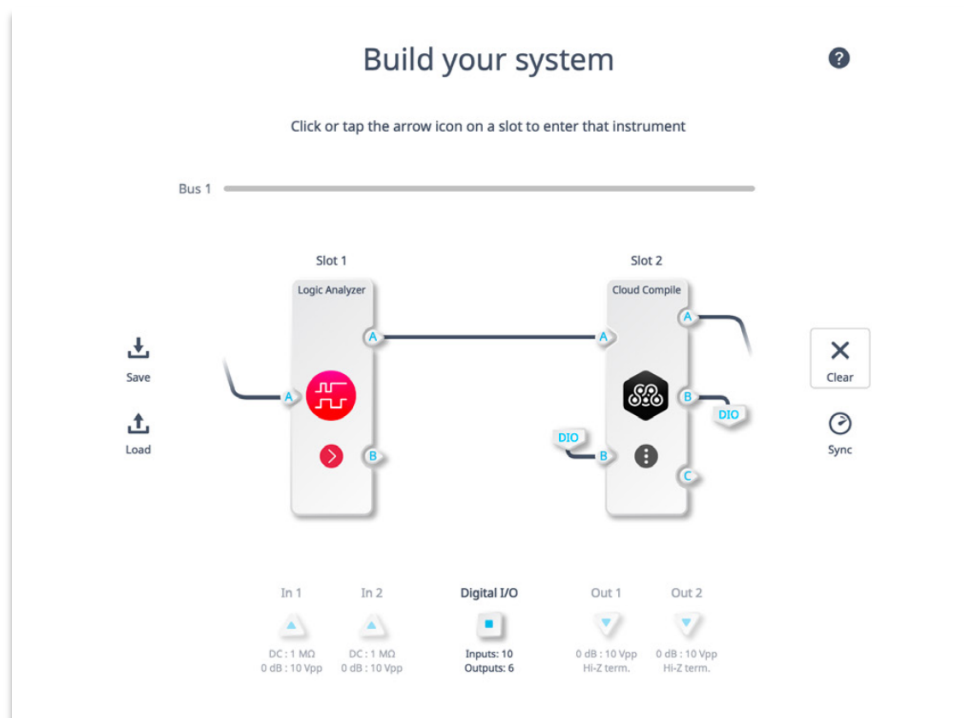

Features

- Configure two independent instruments, operating simultaneously
- Each of the instrument slots has up to two inputs and two outputs
- Flexible multiplexing allows all two slots to access all two ADC inputs and all two DAC outputs
- High-speed, 2 Gb/s inter-instrument communication with drag and drop setup
- Configurable input and output ranges, one-touch slot synchronization



Specifications

Common characteristics

Overview

Instruments	Up to 2, each with up to 2 inputs and 2 outputs
Inputs / outputs	2 analog inputs, 2 analog outputs
Input ranges	10 V _{pp} into 1 MΩ with 0 dB attenuation 50 V _{pp} into 1 MΩ with 14 dB attenuation
Input bandwidth	30 MHz
Input sampling rate	125 MSa/s per channel
Input impedance	1 M Ω
Output ranges	10 V _{pp} into 1 MΩ
Output bandwidth	20 MHz
Output sampling rate	125 MSa/s per channel
Output impedance	200 Ω

Instrument slot

Inter-slot communication	2 channels, each at 16 bits at 125 MHz / 2 Gb/s
Available instruments	Arbitrary Waveform Generator Data Logger Digital Filter Box FIR Filter Builder Frequency Response Analyzer Lock-in Amplifier Logic Analyzer Oscilloscope Phasemeter PID Controller Spectrum Analyzer Time & Frequency Analyzer Waveform Generator Moku Cloud Compile

Moku:Go Power Supply

Description

Moku:Go M1²⁴ and M2 models are equipped with 2 and 4 channel programmable power supplies respectively. The power supply is an embedded peripheral that can be independently configured and used in tandem with any of the Moku:Go instruments. M1 and M2 both provide -5 to 5 V and 0 to 16 V high-accuracy switching supplies for maximum flexibility in dual-rail and high voltage applications such as op-amp characterization and communications. The M2 adds two 0.6 to 5 V supplies. Each is capable of 1 A output currents for laser and motor applications while also being able to power a wide range of USB peripherals.



Features

- Up to four independently adjustable power supply channels.
- Constant voltage or current mode with auto overvoltage and overcurrent protection.
- Fully embedded with other 12 powerful instruments, such as an oscilloscope, waveform generator, etc.

²⁴ The Moku:Go M1 model is a legacy product and has been discontinued.

Specifications

		Port 1 (M1 & M2)	Port 2 (M1 & M2)	Port 3 & 4 (M2)
Output voltage		-5 V to +5 V	0 V to +16 V	0.6 V to +5 V
Output current		0 mA to 150 mA	0 mA to 150 mA	0.07 A to 1 A
Set Resolution		2.5 mV / 10 mA	5 mV / 10 mA	5.8 mV / 1 mA (I < 0.5 A) or 15 mA
Readback Resolution		4 mV / 0.1 mA	4 mV / 0.1 mA	4 mV / 0.1 mA
Set Accuracy	Voltage	≤ 1%	≤ 1%	2 %
	Current	± 10 mA typical	± 10 mA typical	± 10 mA typical
Readback Accuracy	Voltage	± 4 mV ± 1%	± 4 mV ± 1%	± 4 mV ± 1%
	Current	± 100 µA ± 1%	± 100 µA ± 1%	± 100 µA ± 1%
Effective Output Impedance		0.5 Ω	0.5 Ω	< 0.1 Ω
Ripple and Noise ²⁵		7 mV _{rms}	7 mV _{rms}	8 mV _{rms}

PPSU1 Output Noise

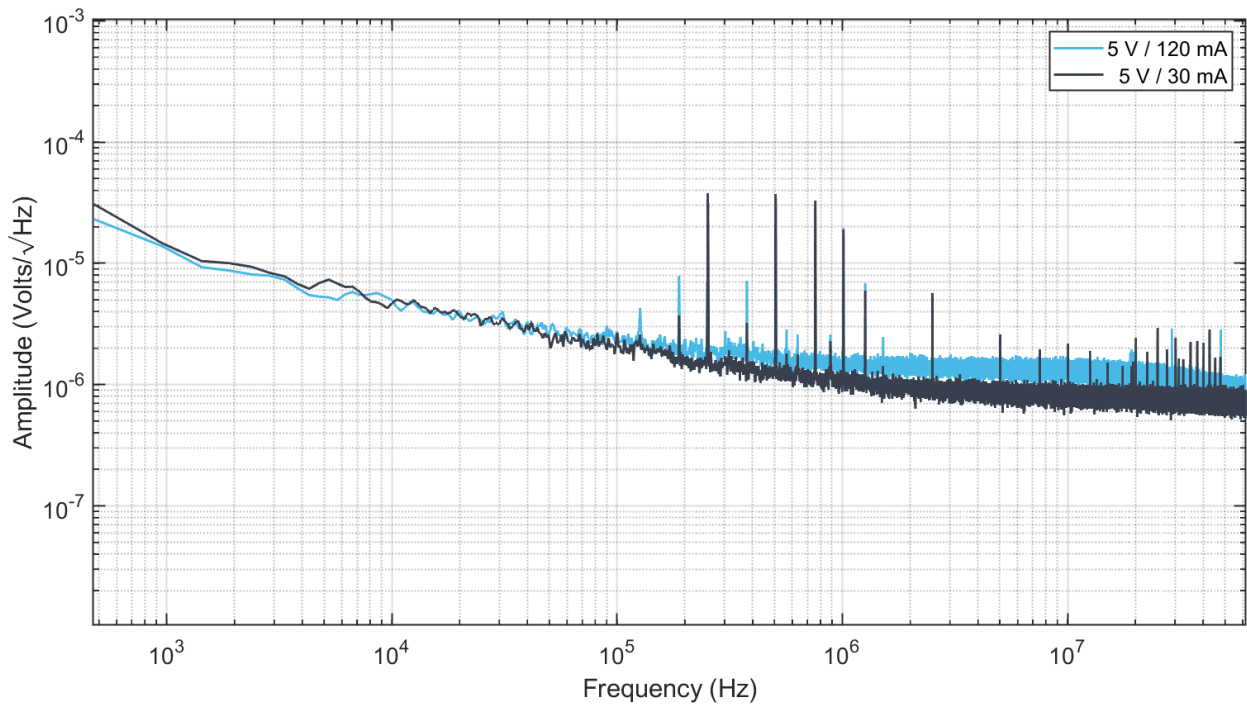

²⁵ RMS noise measurements are bandlimited to 50 MHz and are done at full power supply load.

PPSU2 Output Noise

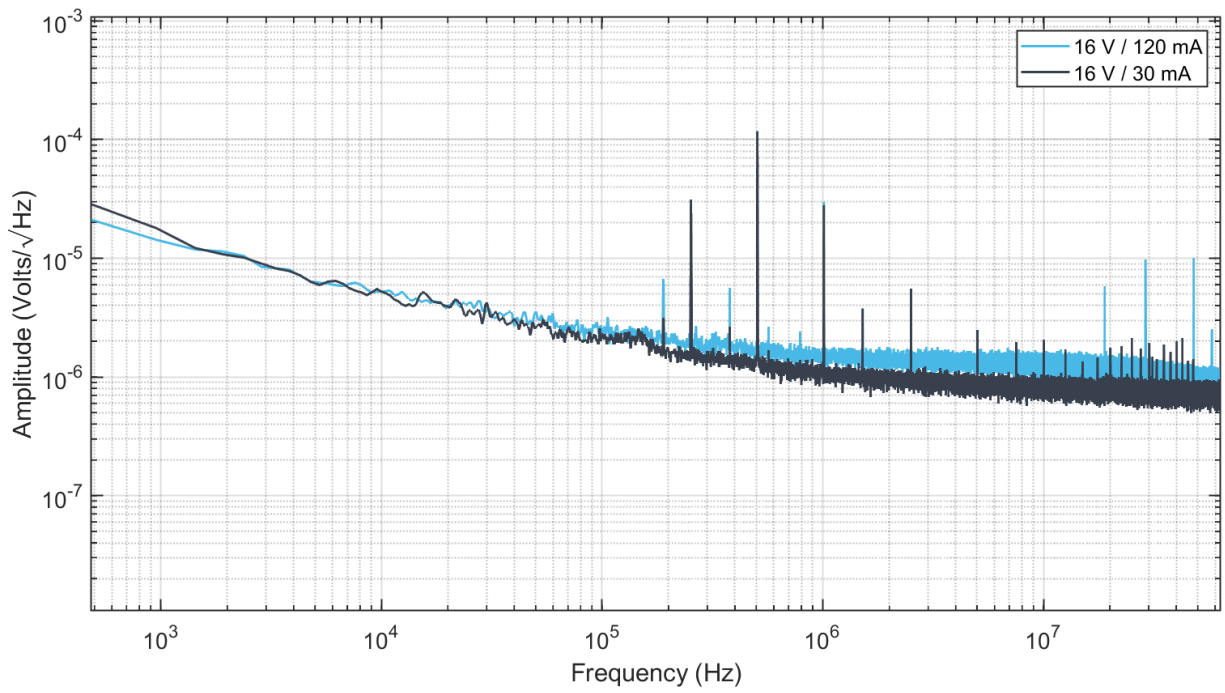

PPSU3 and PPS4 Output Noise

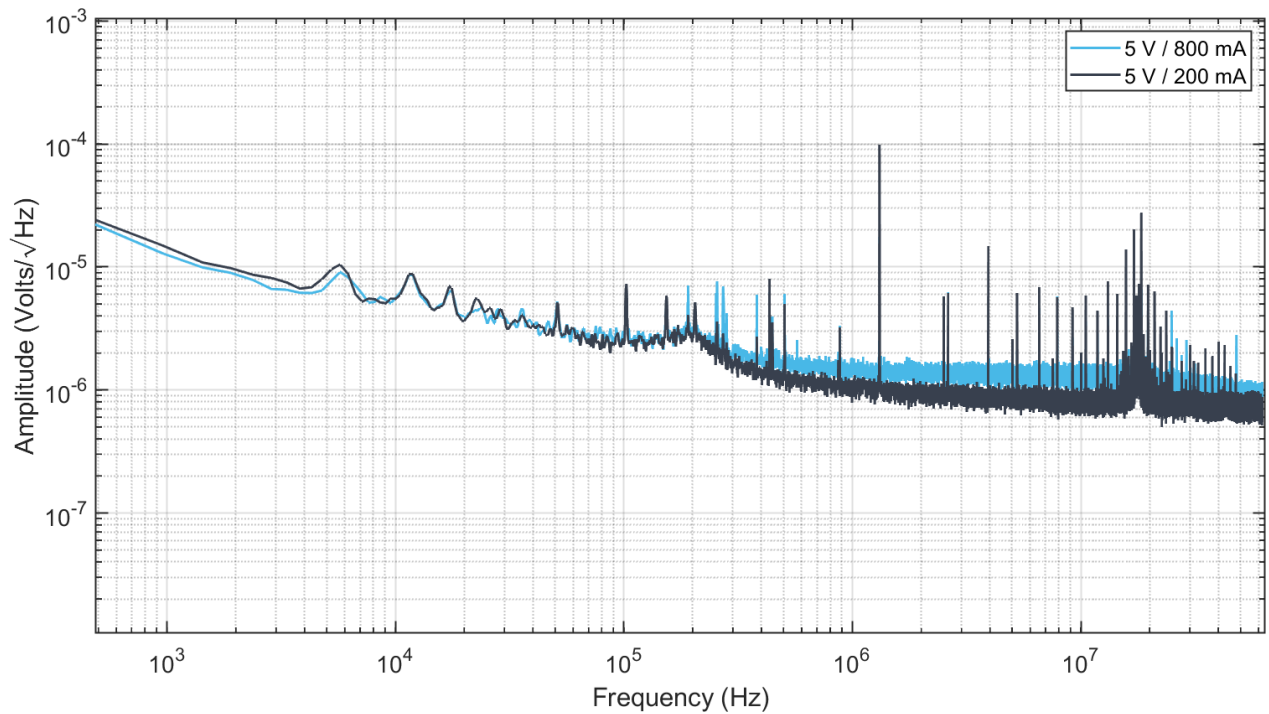

This information is subject to change without notice.

© 2024 Liquid Instruments. All rights reserved.