



## High-Wattage Power Supply Application

By: Weiqiang Wu / Technical Service Center  
[RMA@meanwell.com.cn](mailto:RMA@meanwell.com.cn)

Switching power supplies are the result of the development of power electronics and are now widely used in the majority of electrical devices across many industries, including communication radio frequency transmission equipment, solid-state microwave equipment, intelligent robotics, logistics sorting systems, new energy systems, and other fields. Broadly used in electronic power supply systems, switching power supply is undoubtedly the key component, and its prospect is promising.

Technological progress promotes product innovation. In recent years, switching power supply products are developing in the direction of high frequency, high power density, high power factor, high efficiency, high reliability, and intelligence. The market has taken notice of the innovative functions, particularly the commitment to sustainability. The launch of "green" power supply and modular power supply has played a critical role in energy saving, low consumption, and environmental protection, effectively alleviating energy and environmental crises.

The structural development in the electronic power industry has greatly promoted the market demand for high-wattage power supplies. MEAN WELL has launched a variety of single-phase/three-phase high-power power supplies, such as RST-5000/10000, SHP-10K series, etc. The output voltage and current can be controlled by PV/PC function or communication interface such as CANBus/PMBus/MODbus. Additionally, there are two cooling options to select from, air cooling and water cooling, which can satisfy the application requirements of power systems in diverse industries.

Three real cases are illustrated as follows.

1. In the illustration, the SHP-10K-55 is installed in the solid-state microwave oscillator as follows, providing highly stable DC voltage energy to the power-level microwave energy circuit. The solid-state microwave oscillator then provides controllable and precise microwave energy to the associated equipment, such as industrial microwave heating equipment, Industrial Microwave Drying Equipment, Microwave Plasma equipment, etc.

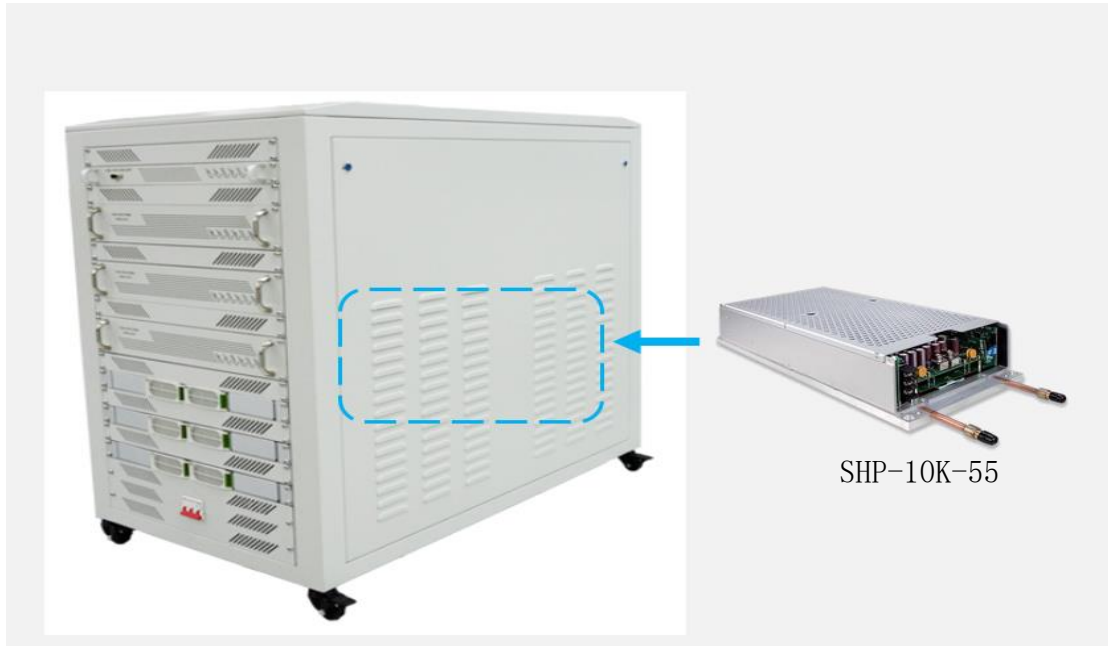

Fig.1 Solid-state Microwave Oscillator Application

2. The PHP-3500-48 installed in the weather radar and satellite communication system can work as the DC power supply for the radio frequency transmission or pulse equipment. It is equipped with a water-cooling plate for heat dissipation, providing a robust and highly reliable DC power supply solution for the entire system.



Fig.2 Radio Frequency Transmission Application

3. The RST-10000-48 is installed in the water electrolysis hydrogen production equipment system, and as the DC power supply for the electrodes in the electrolyzer. The water molecules undergo electrochemical reactions and are decomposed into hydrogen and oxygen. The production of hydrogen determines the power of the power supply.

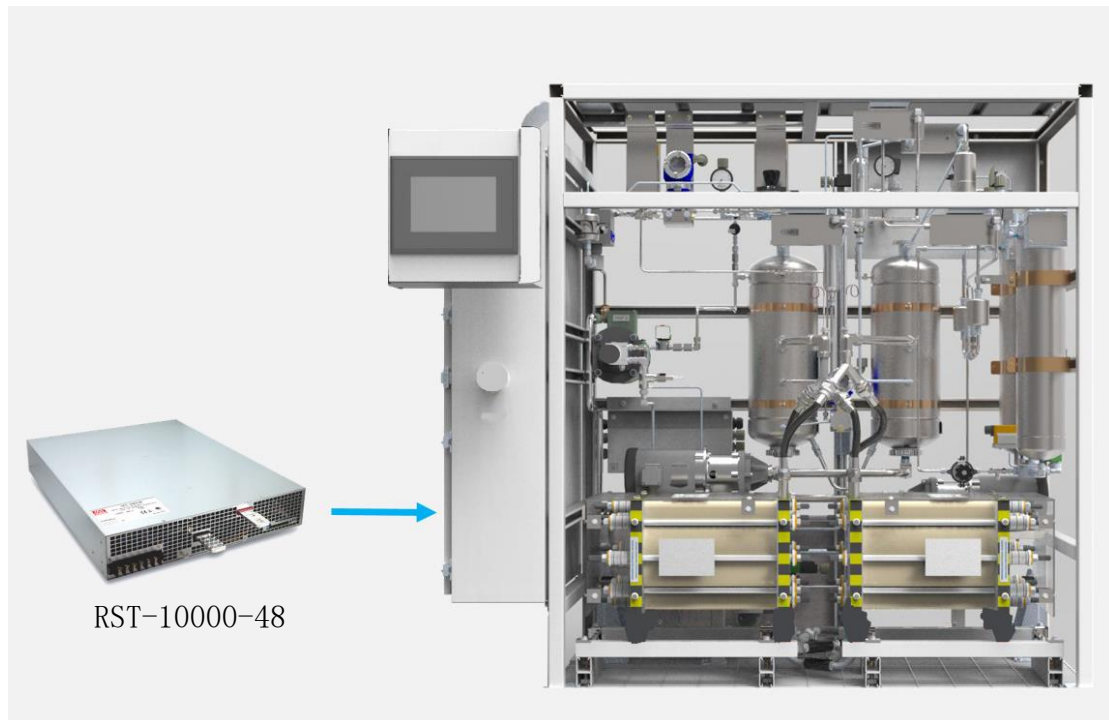

Fig.3 Water Electrolysis Hydrogen Production Equipment System Application

If you have any questions, you can contact MEAN WELL's personal. If you have other demands such as, video, tech notes, FAQ or technical support, you are more than welcomes to access to our technical service hall in our webinar on our website by following links.

Technical service hall

[https://expo.meanwell.com/exhibition\\_12.html](https://expo.meanwell.com/exhibition_12.html)