

Vulcan Versal™ Prime / AI Edge FPGA SoC System-on-Module

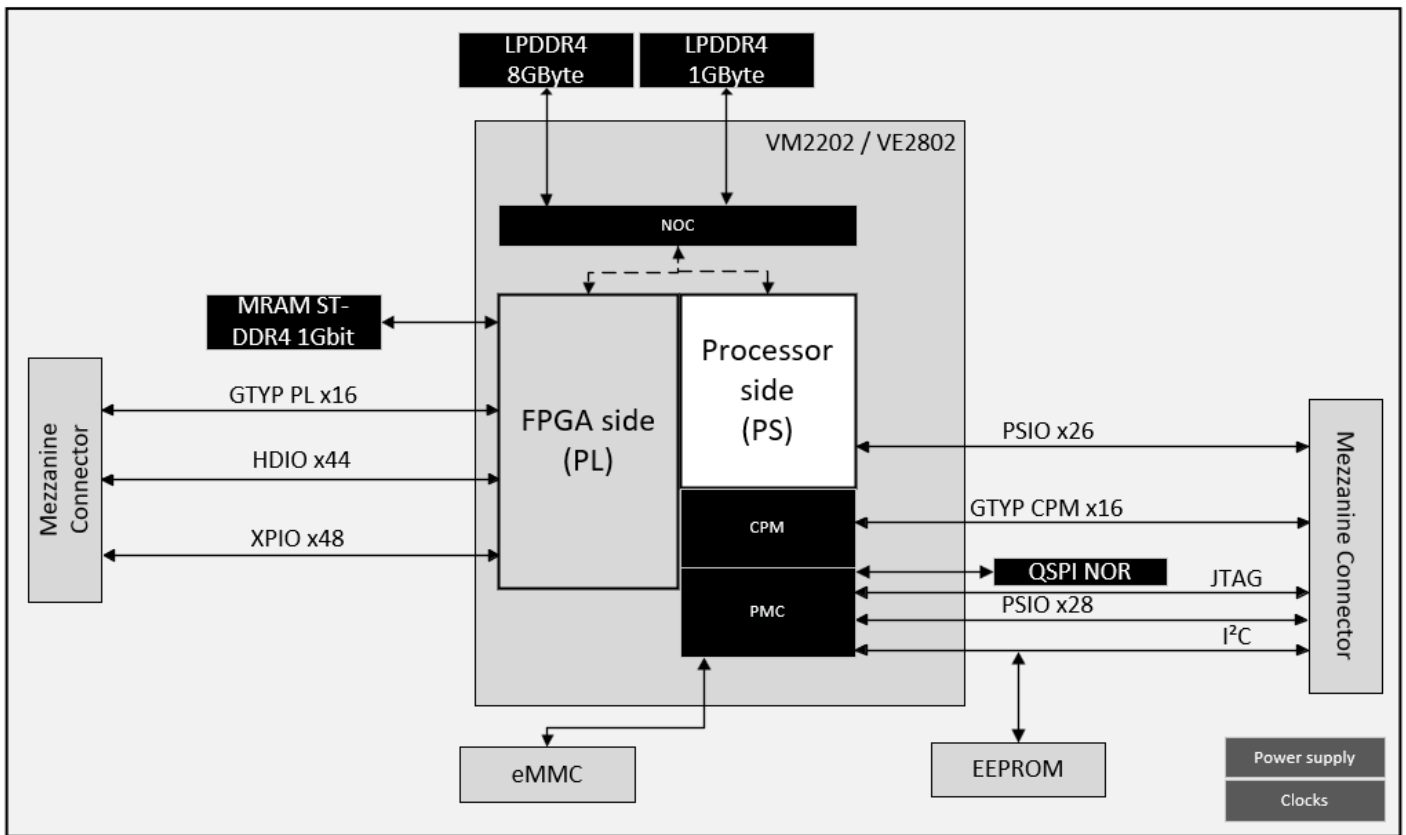
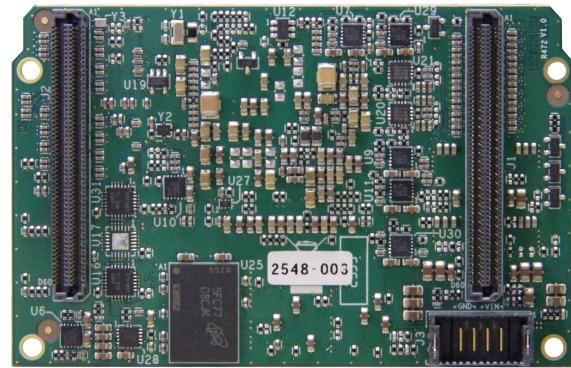
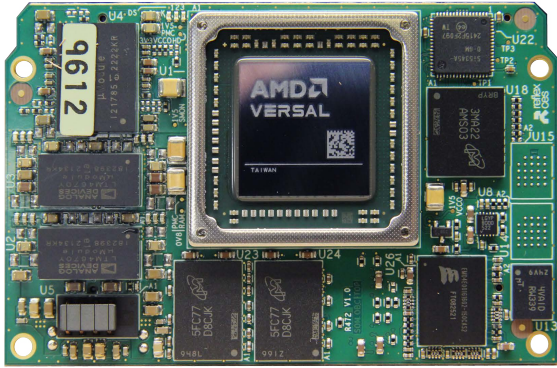

- AMD Xilinx® Versal™ Prime FPGA or AI Edge
 - VM2202 / VE2802
 - 2x PCIe Gen4 x8 End Point or Root Port
 - Dual Core ARM Cortex A-72 and Dual Core ARM Cortex RSF

- 2x PCIe Gen4 x8 interface
- 44x HDIO + 48x XPIO
- 2x LP-DDR4, 1x MRAM ST-DDR4
- Industrial Temp Grade
- Long Term Supply

- Bioscience & Instrumentation
 - Quantum Computing
 - AI Vision Analytics
- Embedded Airborne Systems
 - Radar Systems
 - Electronic Warfare

Features	Vulcan System-on-Module	
Ordering Information	RXCVM2202PH35-SOM001 Availability: End Q1 2026 using Versal™ Prime VM2202	RXCVE2802PH35-SOM001 Availability: End Q2 2026 using Versal™ AI Edge VE2802
FPGA SoC	Versal™ Prime VM2202: 1140 KLC, UltraRAM 74Mbit, 1312 DSP Engines Dual Core Arm Cortex-A72, Dual Core Arm Cortex-R5F Speed grade 1, Industrial temp grade	Versal™ AI Edge VE2802: 304 AI-Engines, 1140 KLC, UltraRAM 74Mbit, 1312 DSP Engines Dual Core Arm Cortex-A72, Dual Core Arm Cortex-R5F Speed grade 1, Industrial temp grade
External Memory	Connected to the NOC = 1x LPDDR4 x64bit, 8GByte, @2400MT/s 1x LPDDR4 x32bit, 1GByte, @2400MT/s Connected to the PL = 1 bank MRAM 1Gbit	
Mezzanine Connectors	16 transceivers GTYP @25Gbps + 16 transceivers GTYP CPM PCIe Gen4 44 HDIO maximum 48 XPIO maximum	
FPGA Configuration	2Gbit Quad SPI Flash	
Software Configuration	128Gbyte NAND Flash eMMC (Stores U-Boot, Linux Kernel, and RootFS)	
PS Communication & Networking	128GByte eMMC 2Mbit EEPROM Min 1520Mb QSPI NOR Flash 54 PSIO (PMC and PS)	
Mechanical & Environmental Specification	EMI immunity : TBD; EMI emission : TBD, Vibration : TBD; Shock : TBD 5V +/- 10% Industrial temperature grade -40°C to +85°C UL 94-V0 compliant components	
Power & Dissipation	Total power estimated at 65.75W active heatsink (heat spreader + heatsink)	Total power estimated at 88W active heatsink (heat spreader + heatsink)
Board Management Controller (via Versal PMC)	Communication with Carrier board: I2C, JTAG Communication with FPGA : UART to FPGA Monitoring : Current, voltages, temperature, ID information Programming : Clock Control: Power, temperature protection	
Module dimensions	84mm x 54mm (3.3 x 2.1 inches)	
Compliance	RoHS/REACH compliant	
Deliverables	<ul style="list-style-type: none"> • Vulcan module & its passive cooling system • Board Support Package (to download from our online technical support) after purchase of a module and its carrier board: <ul style="list-style-type: none"> Starter Guide, module and carrier board Reference Manuals, Interconnect pinout file Mechanical drawings, assembly files FPGA test design (vivado 2024.x version) BMC Software : TBD HPS Software: <ul style="list-style-type: none"> -Build with: TBD -U-boot bootloader • 1-year technical support and warranty • Online support at support.reflexces.com (after purchase of a kit) 	
MOTS = Modified version (on request)	<ul style="list-style-type: none"> • Conformal coating • Custom heatsink system • Contact sales for customization 	

Thermal dissipation

Module dimension: 84mm x 54mm (3.3 x 2.1 inches)

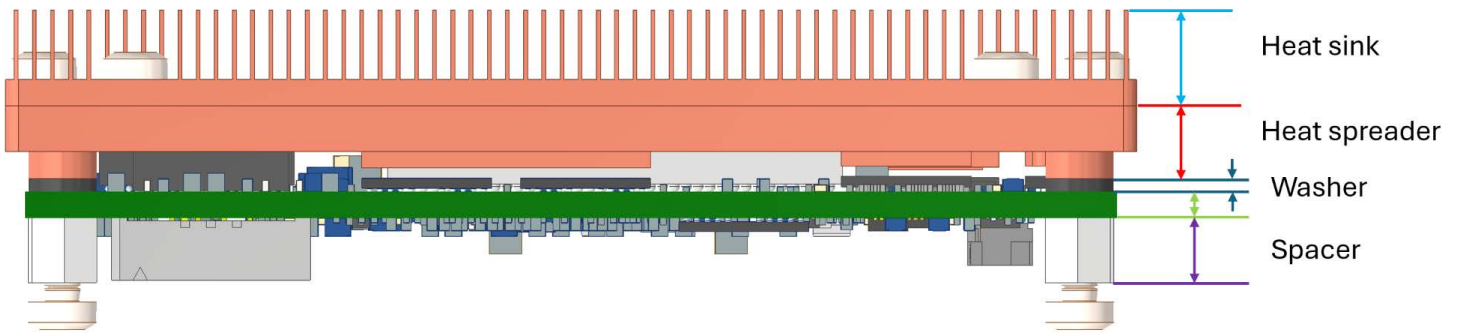

Related product: Carrier Board

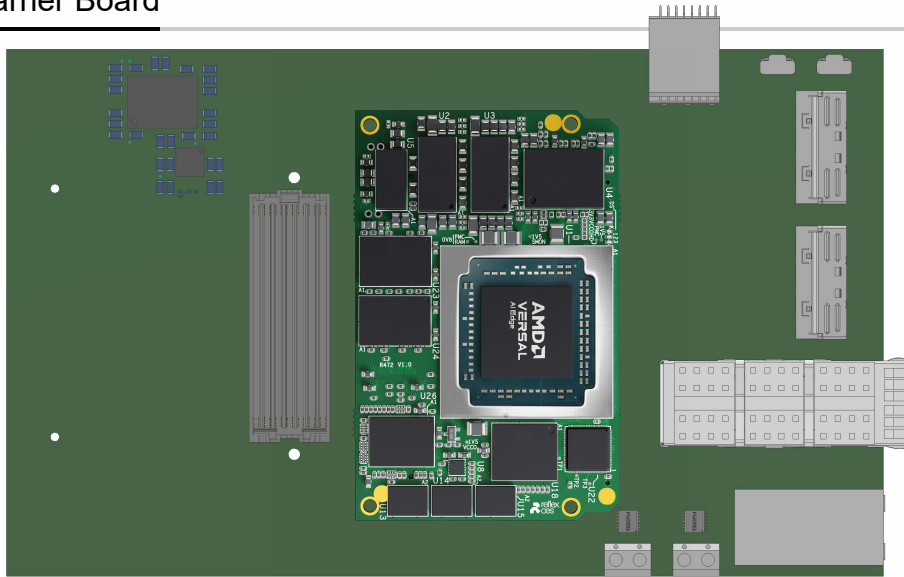

(preliminary view of carrier board)

The Vulcan Carrier board is sold separately

Ordering information: RXCVER-CBD0SA

PL interfaces

FMC+ HPC connector:

- 12x transceivers @25Gbps
- 10x LVDS
- 68x LVCMOS
- 1x I²C

QSFP:

- 4x transceivers @25Gbps
- 1x I²C

PS, PMC and CPM interfaces

- 1x USB for USB 2.0 OTG
- 2x RJ45 for 2x Ethernet @1Gbps
- 1x header for I²C PMC
- 2x headers for 2x CAN 2.0B
- 1x PMOD connector for SPI
- 2x MCIO for 2x PCIe Gen4 x8
- 1x USB for JTAG and UART
- 1 NVMe linked to 1 one of PCIe CPM

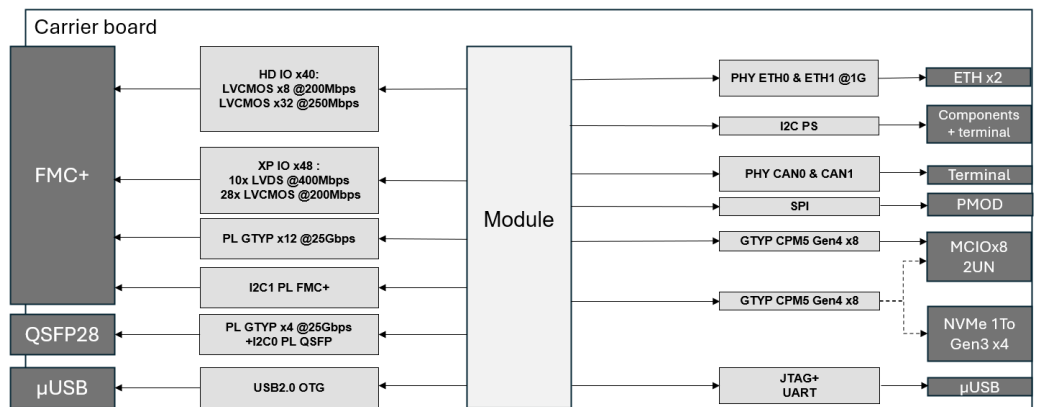

Operating temperature : - 40°C / + 85°C

Board dimensions : TBD

Compliance

- Fully compatible with Vulcan module
- RoHS/REACH compliant, UL compliant, ISO9001 facility