



Product Specification of GI3.0 Multiload Connector

1. SCOPE

1.1. Content

This specification covers performance, tests and quality requirements for the TE Connectivity (TE) Grace Inertial (GI) 3.0 Multiload Connector System. The GI 3.0 Multiload Connector is a wire-to-board and crimp termination technology on variation centerlines (3.55mm,2.30mm) and mate with 0.5 mm square posts providing a reliable interconnection between wires and posts mounted on printed circuit boards. The GI 3.0 Multiload connector system is available in 14P,26P and 28 positions with dual row. It is designed to be terminated to 26 AWG and 28 AWG wire. A complete connector consists of an assembled header and assembled plug housing& receptacle contact. For the header assembly, it provides through hole type. The GI 3.0 Multiload connector can meet glow wire test required by IEC60335-1.

1.2. Qualification

When tests are performed on the subject product line, procedures specified in Figure 1 shall be used. All inspections shall be performed using the applicable inspection plan and product drawing.

1.3. Qualification Test Results

Successful qualification testing on the subject product line was completed between 2023-02-21 and 2023-04-23. The Qualification Test Report number for this testing is 501-106638.

1.4. Revision Summary

Revisions to this specification include:

- First released.

2. APPLICABLE DOCUMENTS AND FORMS

The following documents form a part of this specification to the extent specified herein. Unless otherwise specified, the latest edition of the document applies. In the event of conflict between the requirements of this specification and the product drawing, the product drawing shall take precedence. In the event of conflict between the requirements of this specification and the referenced documents, this specification shall take precedence.

2.1. TE Connectivity Specifications

114-106638	Application Specification
501-106638	Qualification Test Report

2.2. Commercial Standards and Specifications

IEC 60335	International Standard – Safety of Household and Similar Appliance
IEC 60512	International Standard – Connectors for Electronic Equipment – Tests and Measurements
IEC 60695	International Standard – Fire Hazard Testing
UL 1977	Safety Standards – Component Connectors for Use in Data, Signal, Control, and Power Applications
EIA-364	Electrical Connector/Socket Test Procedures Including Environmental Classifications

2.3. Reference Documents

109-1	General Requirements for Testing
102-950	Qualification of Separable Interface Connectors

3. REQUIREMENTS

3.1. Design and Construction

Product shall be of the design, construction, materials and physical dimensions specified on the applicable product drawing.

3.2. Materials

Materials used in the construction of this product shall be as specified on the applicable TE drawing.

Housing: Nylon, PBT

Contacts: Copper Alloy

3.3. Ratings

Voltage Rating: 250VAC

Temperature Rating: -40°C to 105°C

Current Rating: see table 1

Table1- Current Rating Table

Position Wire Size	Current Capacity / A		
	14P	26P	28P
22AWG	3.0Max.	2.0Max.	2.0Max.
24AWG	2.5Max.	2.0Max.	2.0Max.
26AWG	2.5Max.	2.0Max.	2.0Max.
28AWG	1.5Max.	1.5Max.	1.5Max.

Note: Values are based on initial Temperature Rise versus Current Testing and are intended to be a guide in the selection of a connector family. All applications should be tested by end user.

3.4. Performance Requirements and Test Description

The product should meet the electrical, mechanical and environmental performance requirements specified in Figure 1. All tests shall be performed at ambient environmental conditions otherwise specified.

3.5. Test Requirements and Procedure Summary

Unless otherwise specified, all tests shall be performed at ambient environmental conditions.

Test Description	Requirements	Procedures
Initial examination of product.	Meets requirements of product drawing and Application Specification 114-106638.	EIA-364-18. Visual and dimensional inspection per product drawing.
Final examination of product.	Meets visual requirements.	EIA-364-18. Visual examination.
ELECTRICAL		
Low Level Contact Resistance (LLCR).	10 milliohms maximum initial. 20 milliohms maximum final.	EIA-364-23. Subject specimens to 100 milliamperes maximum and 20 millivolts maximum open circuit voltage. See Figure 3.
Insulation resistance.	1000 MΩ minimum initial. 500 MΩ minimum final.	EIA-364-21. Impressed voltage 500VDC. Test between adjacent circuits and between the surface of housing and contact of mated connectors.
Withstanding voltage.	One minute hold with no breakdown nor flashover. 5.0 milliamperes maximum leakage current.	EIA-364-20, Condition I. 1500 volts AC at sea level. Test between adjacent contacts.

Temperature Rise vs. Current.	30°C maximum temperature rise.	EIA-364-70, Method 1. Stabilize at a single current level (See table 1) until 3 readings at 5 minutes intervals are within 1°C.		
MECHANICAL				
Sinusoidal vibration.	No discontinuities of 1 microsecond or longer duration. See Note.	EIA-364-28, Test Condition I. Subject mated specimens to 10 to 55 to 10Hz traversed in 1 minute with 1.5 mm maximum total excursion. 2 hours in each of 3 mutually perpendicular planes.		
Mechanical shock.	No discontinuities of 1 microsecond or longer duration. See Note.	EIA-364-27, Method H. Subject mated specimens to 30 G's half-sine shock pulses of 11 milliseconds duration. Three shocks in each direction applied along 3 mutually perpendicular planes, 18 total shocks.		
Durability.	See Note.	EIA-364-9. Mate and unmate specimens for 25 cycles at a maximum rate of 500 cycles per hour.		
Durability preconditioning.	See Note.	EIA-364-9. Mate and unmate specimens for 5 cycles at a maximum rate of 500 cycles per hour.		
Connector Mating force.	4.0N maximum per contact	EIA-364-13. Measure force necessary to mate specimens fully from point of initial contact at a maximum rate of 12.7 mm per minute. Measure the force required to mate / un-mate connectors without Housing Lock.		
Connector Unmating force.	0.9 N minimum per contact.	EIA-364-13, Method A. Measure force necessary to unmate specimens at a maximum rate of 12.7 mm per minute with latch disengaged.		
Tensile strength of wire termination	Wire size		Crimp Tensile (min.)	EIA-364-8 Apply an axial pull-off load to crimped wire of contact secured on the tester, Operation Speed: 25.4 mm/min. Subject to take insulation barrel away.
	mm ²	AWG	N (Kgf)	
	0.32-0.38	22	49.0 (5)	
	0.2-0.24	24	29.4 (3)	
	0.12-0.15	26	19.6 (2)	
0.089-0.093	28	9.8 (1)		
Connector locking strength.	29.4N minimum	EIA-364-98. Measure connector locking strength at a maximum rate of 12.7mm per minute.		
Post Retention Force	14.7N minimum	EIA-364-29 Measure post retention at a maximum rate of 25.4 mm per minute.		
Contact Insertion Force	7.84 N (maximum) per Contact	EIA-364-5 Measure contact insertion force at a maximum rate of 25.4 mm per minute.		
Contact Retention Force	19.6 N (minimum) with TPA	EIA-364-29, Method C Operation Speed: 25.4 mm/min		

ENVIRONMENTAL		
Thermal shock.	See Note.	EIA-364-32, Test Condition VII. Subject mated specimens to 10 cycles between -55 and 105°C with 30 minutes dwells at temperature extremes and 5 minutes transition between temperatures.
Humidity/temperature cycling.	See Note.	EIA-364-31, Method III. Subject specimens to 10 cycles (10 days) between 25 and 65°C at 90 to 95% RH.
Temperature life.	See Note.	EIA-364-17, Method A, Test Condition 4, Test Time Condition C. Subject mated specimens to 105°C for 96 hours.
Salt spray.	See Note.	EIA-364-26. Subject mated specimens to 5% salt concentration for 48 hours.
Hydrogen sulfide.	See Note.	Subject mated specimens to 3 ± 1 ppm H ₂ S gas concentration maintained at 40 ± 2°C for 96 hours.
Ammonia.	See Note.	Subject mated specimens in atmosphere that rated 25 mL/L of 3% NH ₃ for 7 hours.
Resistance to Cold	See Note.	IEC 60068-2-1 Mated connectors, -40±2°C, 96 hours
Resistance to soldering heat.	See Note.	Follow TE spec 109-202 condition C Solder Temperature: 260 +0/-5°C Immersion Duration: 5 +2/-0 Sec
Solderability	Wet Solder Coverage 95% Min.	TEC-109-11 Method B Solder Temperature: 240±5°C Immersion duration: 3±0.5s Flux: Non-activated rosin base. Steam aging for 8 hours.
GWEPT750°C	Flame time Te-Ti ≤ 2s, or no flame.	Test condition following IEC 60695-2-11, test at 750°C Criteria of test result following IEC 60335-1. Flame time Te-Ti ≤ 2s, or no flame. Perform visual check and take picture after the test.

Figure 1



NOTE

Shall meet visual requirements, show no physical damage, and meet requirements of additional tests as specified in the Product Qualification and Requalification Test Sequence shown in Figure 2.

3.6. Product Qualification and Requalification Test Sequence

Test or Examination	Test Group (a)															
	1	2	3	4	5	6	7	8	9	10	11	12	13	14	15	16
	Test Sequence (b)															
Initial examination of product	1	1	1	1	1	1	1	1	1	1	1	1	1	1	1	1
LLCR	3,7	2,4	2,5									2,4	2,4	2,4	2,4	
Withstanding voltage					3,7											
Insulation resistance					2,6											
Temperature rise vs. current				2												
Sinusoidal vibration	5															
Mechanical shock	6															
Durability	4															
Durability preconditioning			3													
Connector Mating force	2															
Connector Unmating force	8															
Tensile strength of wire termination						2										
Contact Insertion Force								2								
Contact Retention Force								3								
Resistance to soldering heat							2									
Connector locking strength									2							
Post retention force										2						
Solderability											2					
Thermal shock					4											
Humidity/temperature cycling			4		5											
Temperature life		3														
Salt spray												3				
Hydrogen sulfide													3			
Ammonia														3		
Resistance to Cold																3
Glow Wire Test																2
Final examination of product	9	5	6	3	8	3	3	4	3	3	3	5	5	5	5	3

Figure 2



NOTE

- (a) See paragraph 4.2.
- (b) Numbers indicate sequence in which tests are performed.

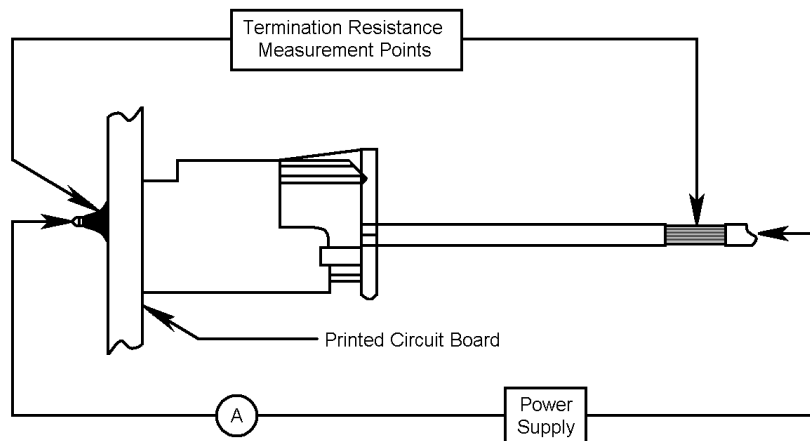

Figure 3
LLCR Measurement Points
(Subtract Wire Bulk)

4. QUALITY ASSURANCE PROVISIONS

4.1. Test Conditions

Unless otherwise specified, all the tests shall be performed in any combination of the following test conditions shown in Figure .

Temperature	15°C – 35°C
Relative Humidity	45% – 75%
Atmospheric Pressure	86.6 – 106.6 kPa

Figure 4

4.2. Qualification Testing

A. Specimen Selection

Specimens shall be prepared in accordance with applicable instruction sheets and shall be selected at random from current production.

B. Test Sequence

Qualification inspection shall be verified by testing specimens as specified in Figure 2.

4.3. Requalification Testing

If changes significantly affecting form, fit or function are made to the product or manufacturing process, product assurance shall coordinate requalification testing, consisting of all or part of the original testing sequence as determined by development/product, quality and reliability engineering.

4.4. Acceptance

Acceptance is based on verification that the product meets the requirements in Figure 1. Failures attributed to equipment, test setup or operator deficiencies shall not disqualify the product. If product failure occurs, corrective action shall be taken and specimens resubmitted for qualification. Testing to confirm corrective action is required before resubmittal.

4.5. Quality Conformance Inspection

The applicable quality inspection plan shall specify the sampling acceptable quality level to be used. Dimensional and functional requirements shall be in accordance with the applicable product drawing and this specification.