

0.5mm Pitch Vertical Mating Connectors for Thin Wire Coaxial Cable

DF80 Series

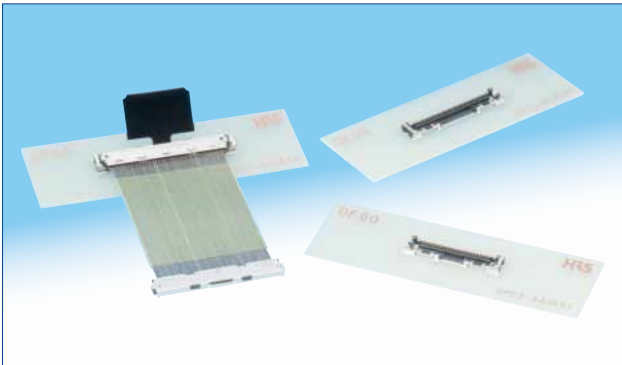

■ Features

1. Supports high speed connections

The single row alignment utilizes a 0.5mm pitch to support 2.7Gbps & 5.4Gbps speeds and produces excellent signal characteristics. Supports eDP™ [Embedded DisplayPort™] version 1.3

2. Maximizes space

Designed to be a space saving connector, this series features a 0.5mm pitch, a low-mated height, and a single row layout in a vertical mating style.

3. Excellent mating operation

It features long mating guides and a generous lead in opening that makes it easy to visually check the connection. (Lead-in amount : $\pm 1\text{mm}$)(Fig. 1)

4. Reliable contact structure

The DF80 series utilizes its effective contact length (0.5mm) and a 2 point type contact structure to ensure high contact reliability.(Fig. 2)

5. Shield performance enhancement

By utilizing multiple contacts between the plug and receptacle shells, the shielding performance is enhanced and creates a more reliable contact. (Fig. 3)

6. Durable plug structure

The plug has two metal covers around it to form a rigid structure.

7. Secure locking system with a clear tactile click

A tactile click ensures that the lock function has been completed and is properly secured. This system also produces excellent lock retention.

8. Structure supports a pull tab

The structure was designed to allow a pull tab to be utilized to aid in un-mating the connector.

9. Halogen-free and RoHS compliant

All materials and substances used to produce these parts comply with the Halogen-free and RoHS free standards.

* Defined according to IEC 61249-2-21.

Br: 900 ppm or below, Cl : 900 ppm or below,

Br+Cl: 1,500 ppm or below

Superb mating operability

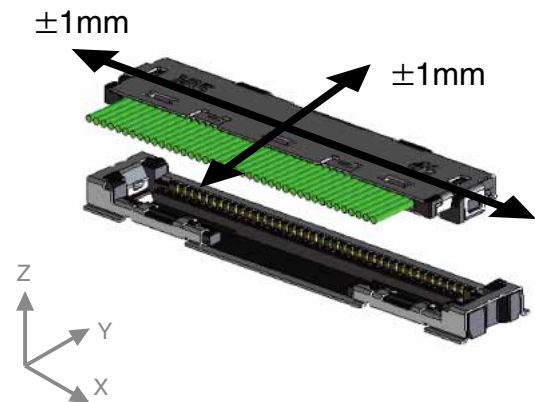

Fig. 1

High contact reliability

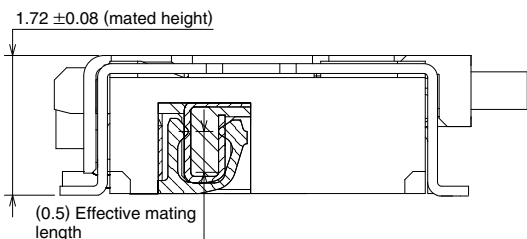
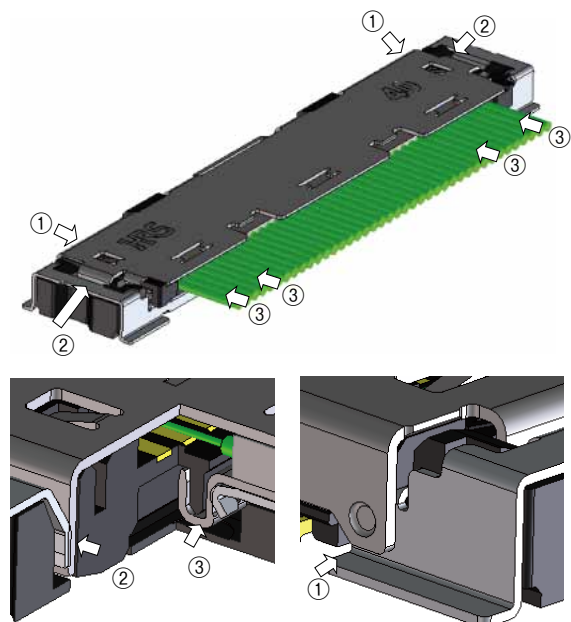

Fig. 2

Shield performance enhancement



Multiple ground springs/points (8 places) Fig. 3

Product Specifications

Ratings	Rated Current	【Discreet Cable】 32 AWG : 0.5A 36 AWG : 0.35A 【Thin wire coaxial cable】 (Note 3) 40 AWG : 0.2A 42 AWG : 0.2A 44 AWG : 0.15A 46 AWG : 0.1A	Operating Temperature Range Operating Humidity Range	-35~+85°C (Note 1) 20 to 80%
	Rated Voltage	AC/DC 50V	Storage Temperature Range Storage Humidity Range	-10~+60°C (Note 2) 40~70% (Note 2)

Items	Specifications	Conditions
1. Insulation Resistance	Minimum of 50MΩ	Measured with DC 100V
2. Withstanding Voltage	No flashover or breakdown	Apply AC 150V for 1 minute
3. Contact Resistance	Signal : Maximum of 80mΩ GND : Maximum of 80mΩ	100mA (DC or 1,000Hz) measurement
4. Vibration Resistance	No electrical discontinuity of 1μs or greater	10 cycles in each of three directions at frequency 10-55Hz, half amplitude 0.75mm
5. Humidity Resistance	Contact resistance (difference from initial state) Maximum of 50mΩ Insulation resistance Minimum of 25mΩ	Left at temperature 40±2°C, humidity 90 to 95%, 96 hours
6. Temperature Cycles	Contact resistance (difference from initial state) 50mΩ or below, Insulation resistance 25mΩ or above	(-55°C : 30 minutes → 5~35°C : 2~3 minutes → 85°C : 30 minutes → 5~35°C : 2~3 minutes) 5 cycles
7. Durability	Contact Resistance : Maximum of 50mΩ	30 mating cycles
8. Soldering Heat Resistance	Should be no melting of resin parts that affects its performance	Reflow : according to the Recommended Temperature Profile Hand solder : Soldering iron temperature 350°C, 3 seconds

Note 1 : Includes the temperature rise caused by current flow.

Note 2 : The term "storage" refers to products stored for a long period prior to mounting and use. The operating temperature and humidity range covers the non-energized condition of installed connectors in storage, shipment or during transportation after board mounting.

Note 3 : With only the connector portion at an elevated temperature level, the rated current value is set.

Materials / Finish

Product	Component	Materials	Finish	Specifications
Receptacle	Insulator	LCP	Black	UL94V-0
	Contact	Phosphorous bronze	Gold plating	—
	Metal fitting	Phosphorous bronze	Tin plating	—
Plug	Insulator	LCP	Black	UL94V-0
	Contact	Phosphorous bronze	Gold plating	—
	Outer Shell	Stainless steel	Tin plating	—
Shell	Outer Shell	Stainless steel	Tin plating	—

Product Number Structure

Refer to the chart below when determining the product specifications from the product number. Please select from the product numbers listed in this catalog when placing orders.

Connector

DF 80 - * S - 0.5 V ()**

① ② ③ ④ ⑤ ⑥ ⑦

DF 80 - * P - SHL

① ② ③ ④ ⑧

① Series Name : DF	⑥ Termination method V : Vertical SMT SD : Thin wire coaxial plug
② Series No. : 80/80 D	
③ No. of Contacts : 30, 40, 50	⑦ Packaging Type (51) Embossed packaging
④ Connector Type S : Receptacle P : Plug	
⑤ Contact pitch : 0.5mm	⑧ Separately installed parts SHL : Outer shell

Receptacle (SMT)

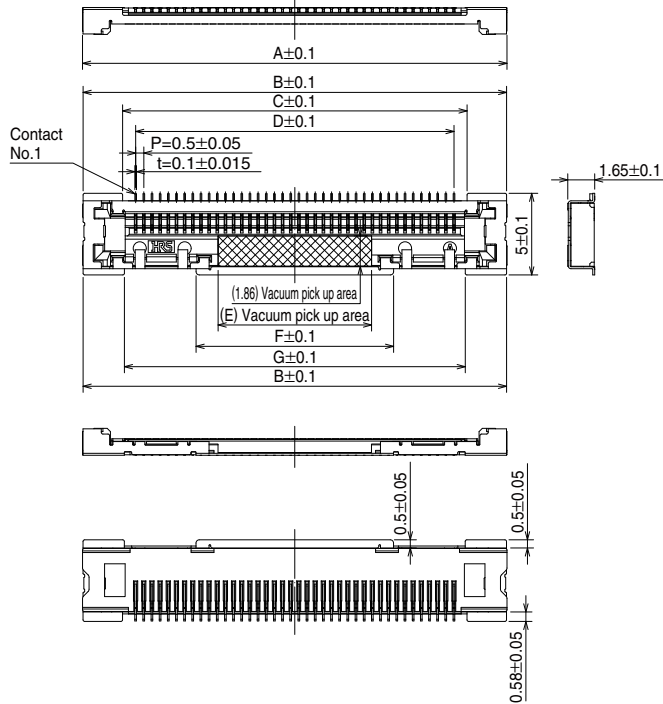

【Specification No.】 - **, (**)
(51) : Embossed packaging

Unit : mm

Part No.	HRS No.	No. of Contacts	A	B	C	D	E	F	G
DF80-30S-0.5V(**)	662-8004-0 **	30	21.00	20.94	16.10	14.50	4.40	7.10	15.88
DF80-40S-0.5V(**)	662-8001-2 **	40	26.00	25.94	21.10	19.50	9.40	12.10	20.88
DF80-50S-0.5V(**)	662-8007-9 **	50	31.00	30.94	26.10	24.50	14.40	17.10	25.88

Note 1 : This product is sold in full reel quantities of 5,000 pcs/reel. Please place orders by full reel quantities.

Recommended PCB layout

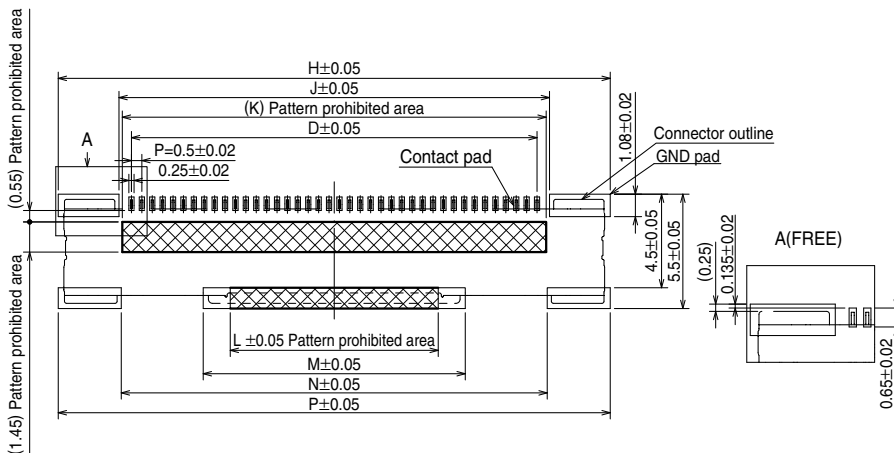

Unit : mm

Part No.	HRS No.	No. of Contacts	H	J	K	D	L	M	N	P
DF80-30S-0.5V(**)	662-8004-0 **	30	21.54	15.70	15.38	14.50	5.00	7.60	15.48	21.54
DF80-40S-0.5V(**)	662-8001-2 **	40	26.54	20.70	20.38	19.50	10.00	12.60	20.48	26.54
DF80-50S-0.5V(**)	662-8007-9 **	50	31.54	25.70	25.38	24.50	15.00	17.60	25.48	31.54

■ Plug

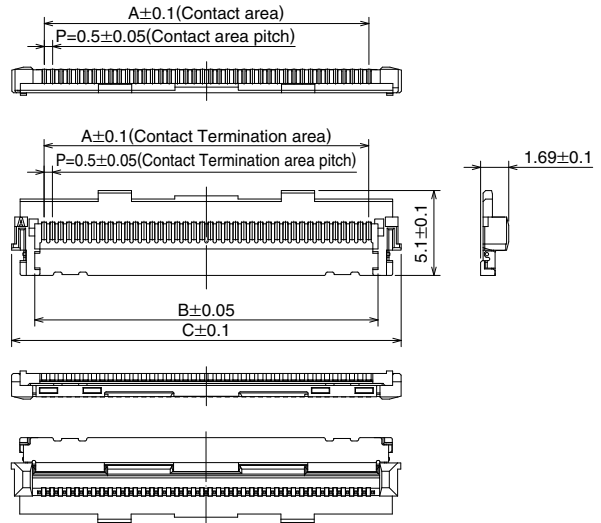

[Specification No.] - **, (**)
(51) : Embossed packaging

Unit : mm

Part No.	HRS No.	No. of Contacts	A	B	C	D
DF80D-30P-0.5SD(**)	662-8018-5 **	30	14.50	15.62	18.40	15.48
DF80D-40P-0.5SD(**)	662-8118-0 **	40	19.50	20.62	23.40	20.48
DF80D-50P-0.5SD(**)	662-8020-7 **	50	24.50	25.62	28.40	25.48

Note 1 : This product is sold in full reel quantities of 5,000 pcs/reel. Please place orders by full reel quantities.
 Note 2 : When terminating electric wire, the outer shell (DF80-*P-SHL) is required.

◆ Recommended wire preparation diagram

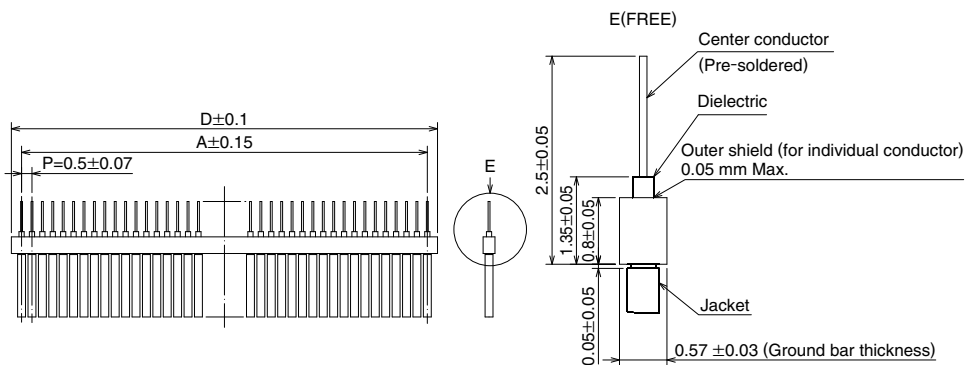

Note 1 : Pre-soldering with lead free solder is required for the center conductor.

Outer shell

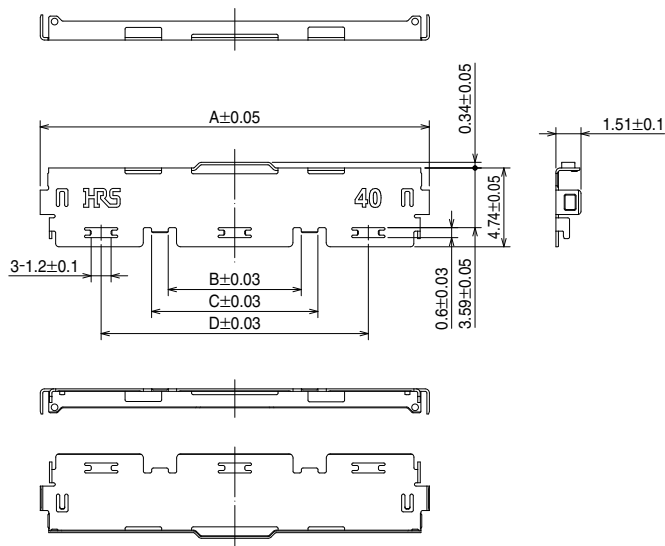
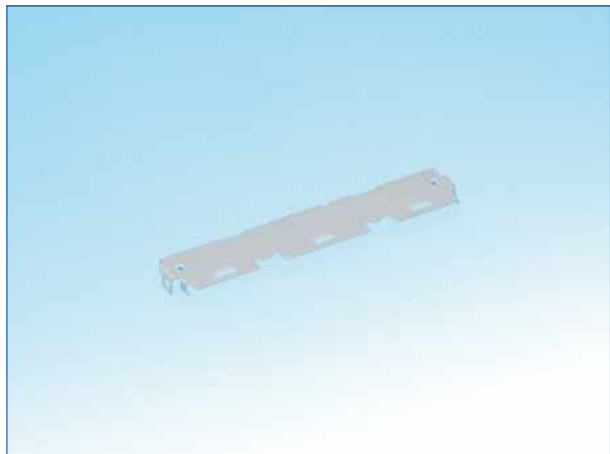

Unit : mm

Part No.	HRS No.	No. of Contacts	A	B	C	D
DF80-30P-SHL	662-8006-6	30	18.40	4.50	6.50	11.07
DF80-40P-SHL	662-8003-8	40	23.40	8.00	10.00	16.07
DF80-50P-SHL	662-8009-4	50	28.40	10.00	12.00	21.07

Note 1 : This product is sold in full reel quantities of 10,000 pcs/reel. Please place orders by full reel quantities.

◆ Embossed tape and reel dimensions (JIS C 0806/IEC60286 compliant)

● Receptacle

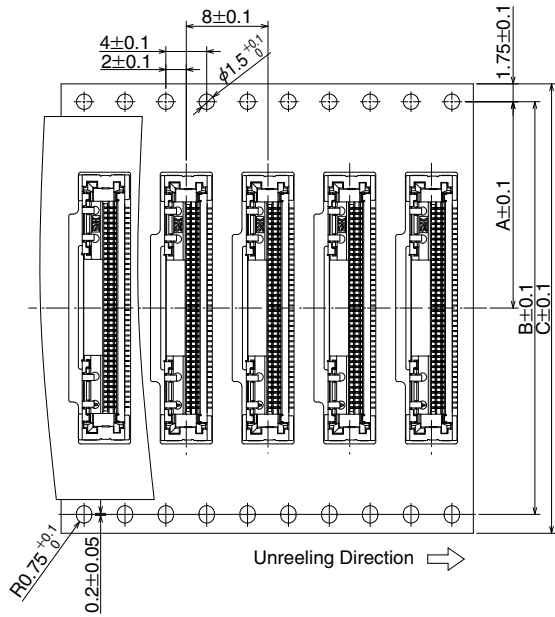

● Reel Dimensions

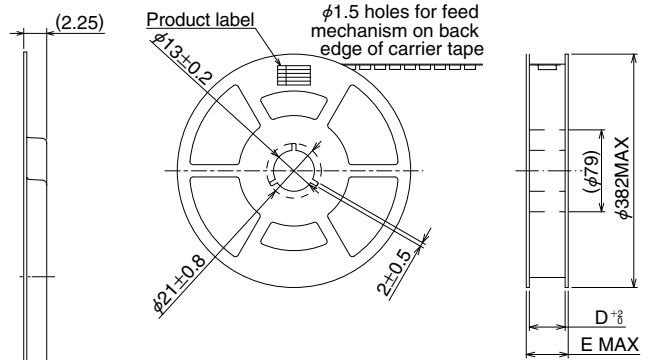

Unit : mm

Part No.	HRS No.	No. of Contacts	A	B	C	D	E
DF80-30S-0.5V(51)	662-8004-0 51	30	20.2	40.4	44.0	44.4	50.4
DF80-40S-0.5V(51)	662-8001-2 51	40	20.2	40.4	44.0	44.4	50.4
DF80-50S-0.5V(51)	662-8007-9 51	50	20.2	40.4	44.0	44.4	50.4

◆ Embossed tape and reel dimensions (JIS C 0806/IEC60286 compliant)

● Plug

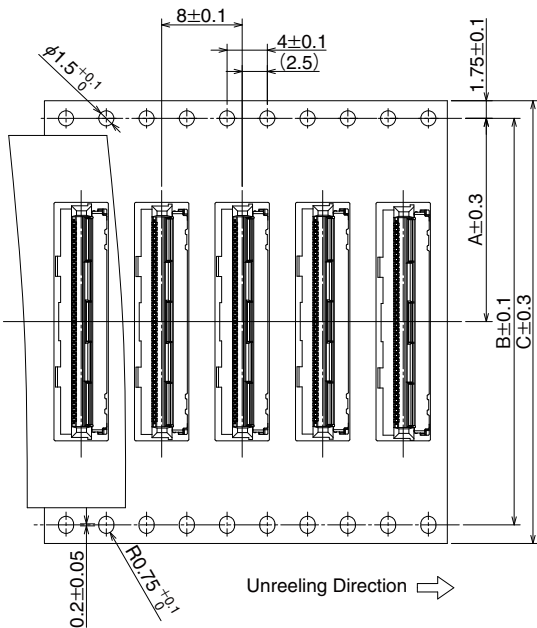

● Reel Dimensions

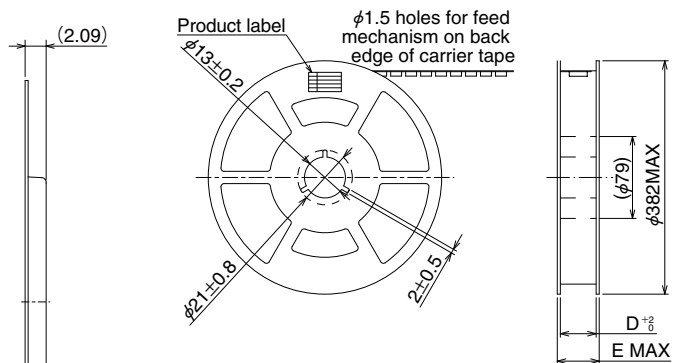

Unit : mm

Part No.	HRS No.	No. of Contacts	A	B	C	D	E
DF80D-30P-0.5SD(51)	662-8018-5 51	30	20.2	40.4	44.0	44.4	50.4
DF80D-40P-0.5SD(51)	662-8118-0 51	40	20.2	40.4	44.0	44.4	50.4
DF80D-50P-0.5SD(51)	662-8020-7 51	50	20.2	40.4	44.0	44.4	50.4

Jun. 1. 2025 Copyright 2025 HIROSE ELECTRIC CO., LTD. All Rights Reserved.

Operating Precautions

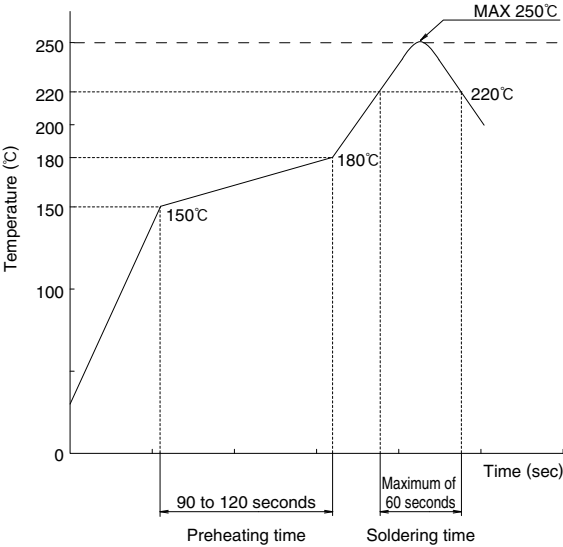
<p>1. Recommended Soldering Profile (Supports lead-free mounting)</p>	 <p>[Applicable Conditions]</p> <ol style="list-style-type: none"> 1. Peak temperature : 250°C MAX 2. Heating parts : 220°C or above, within 60 seconds 3. Preheating parts : 150 to 180°C, 90 to 120 seconds 4. Number of times : No more than 2 times <p>*Solder composition : Sn- 3 Ag- 0.5 Cu</p> <p>Note 1 : This temperature profile is recommended values.</p>
<p>2. Recommended hand solder conditions</p>	<p>The maximum temperature of the soldering iron should be 350°C with a maximum contact time of three seconds.</p>
<p>3. Recommended screen thickness : Opening ratio (pattern area ratio)</p>	<p>Thickness : 0.1mm, opening ratio : lead 100%, ground 100%</p>
<p>4. Leaning of PCB</p>	<p>Maximum of 0.02mm at the center of connector (using both edges of connector as criteria)</p>
<p>5. Washing conditions</p>	<p>IPA washing OK. (Washing is not recommended as it may alter the tactile click feel upon mating. Please contact your local rep if you plan on using another cleaning agent.)</p>

Jun. 1. 2025 Copyright 2025 HIROSE ELECTRIC CO., LTD. All Rights Reserved.

Operating Precautions

Operating Precautions

Connector mating procedure

- When inserting the plug, press straight down on the entire surface of the plug until it is completely inserted.
- Do not press down on the wires when mating. Inserting the plug while pressing down on the wires may cause an angled insertion to occur and may result in damage to the connector.

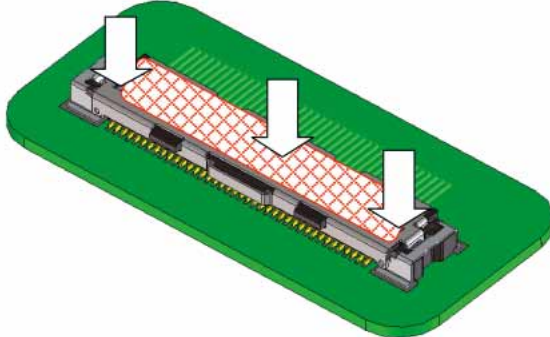

Connector unmating procedure

- Un-mating the connector can be done in two different methods : unmating with fingers or with the pull tab.
- Do not pull/hold on the terminal wires during extraction. Doing so can lead to damaged or disconnected wires.

[Unmating with fingers]

Pull up on the extension hook that is part of the connectors plug.

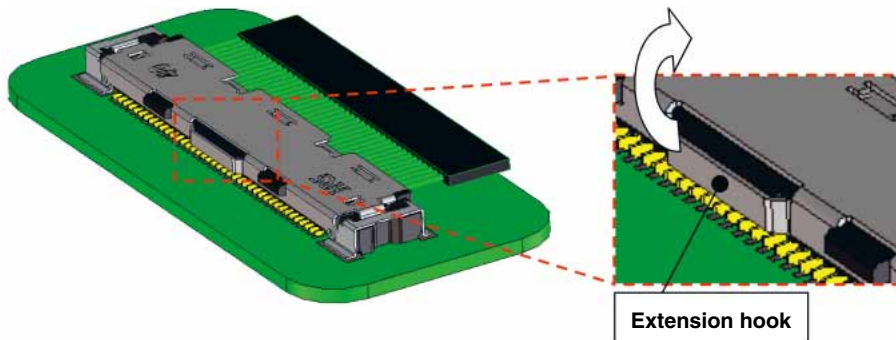

- The extension hook is made of metal, so please use caution when manipulating it as it may cause damage to your nail or finger.

[Unmating with pull tab]

Pull up on the tab in the arrowed direction (vertically) to extract the plug.

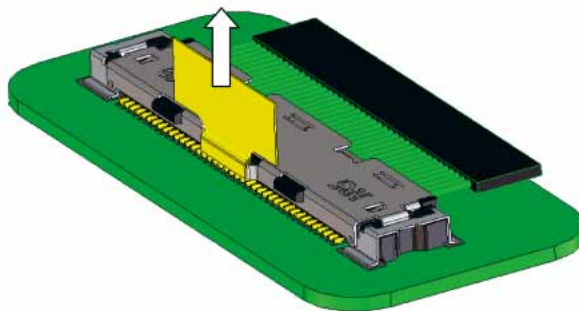

■ Do not mate and unmate this connector if it has not been mounted on a PCB, doing this can damage and deform the contacts.

■ Using excessive force while mating or unmating will damage the contacts or connector.

■ When hand soldering, do not apply excessive amounts of flux. Doing so may promote solder wicking.



HIROSE ELECTRIC CO.,LTD.

2-6-3,Nakagawa Chuoh,Tsuzuki-Ku,Yokohama-Shi 224-8540,JAPAN

TEL: +81-45-620-3526 Fax: +81-45-591-3726

<http://www.hirose.com>

<http://www.hirose-connectors.com>