

DF62W Series

Water Resistant, Slim In-line Connector for Internal Wiring



Positive-Lock



Waterproof



Slim In-Line

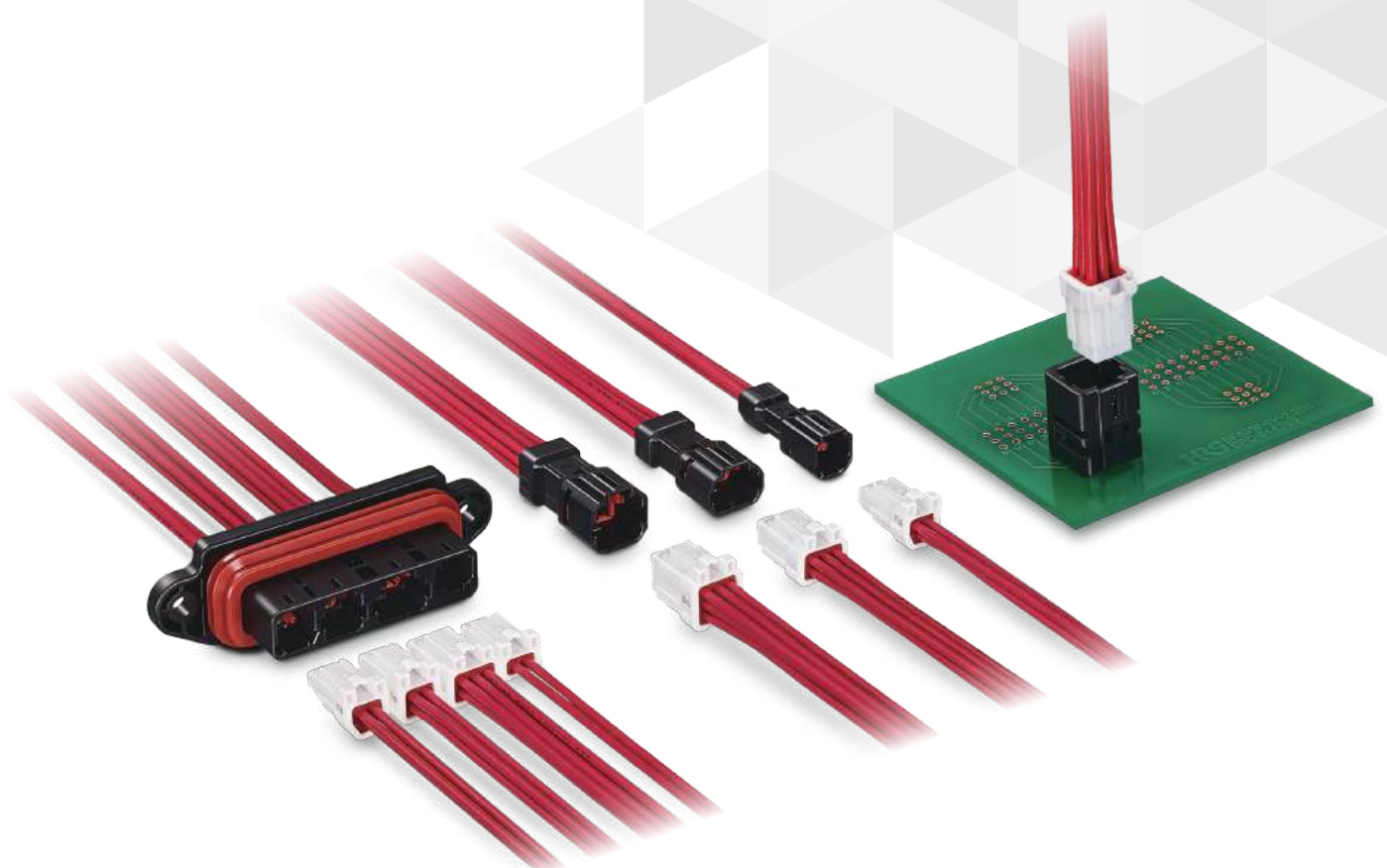

Mar. 1. 2026 Copyright 2026 HIROSE ELECTRIC CO., LTD. All Rights Reserved.



Features

1. IP65/IP67

IP65/IP67 waterproof and dustproof performance when mated.

Refer to the Harness Manual for the handling precautions of the harness.

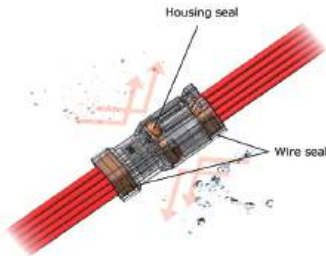

2. The slim, sleek design and smooth contour combine to complete connections in tight spaces.

These connectors were designed to take full advantage of small/ narrow spaces. The contacts are arranged in a grid pattern which shortens the diagonal distances and the body was slimmed down by creating smooth outer surfaces. This design helps to save precious space and makes these connectors virtually tangle free. There is no visible or exposed metal which eliminates the possibility of electrical arcing between the connector and the inside of a metal conduit.

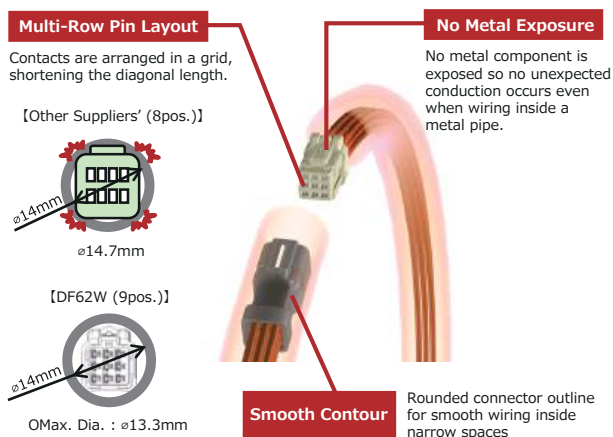

3. Secure Lock Mechanism

The friction lock emits a clear tactile click upon lock completion. The design prevents incomplete mating and connector disconnection. The socket lock can be visually checked through the plug window after mating.



Visible Lock Design

Lock on socket is visible through the slit on the plug when locking is complete, which prevents incomplete mating.

4. Reliable Contact Design

Two-point contact design that maintains contact reliability.

5. Robust Contact Design

The unique design protects the contacts and lance areas. It prevents any bending or deformity that might occur during mating, assembly or transportation.

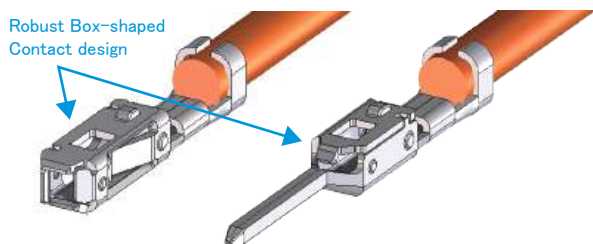

6. Various Variations

Several product variations are available so designers can choose the one most suited to their application. In-line (standard type, thin wire compatible type), waterproof cap, panel waterproof, pin header.



7. Applicator Sharing

DF62W is compatible with the DF11, DF59 and DF62 Series applicators by exchanging the parts.

Note 1: DF62W requires a dedicated die and hand tool.

Note 2: Some products are not compatible. Please contact Hirose for additional details.

8. Glow Wire Compliance (Compliant with IEC 60695-2-11)

9. UL, C-UL Certified (Rated voltage 250V AC/DC)

Product Specifications

Rated Current (Note1)	No of Pos.	20 AWG	22 AWG	24 AWG	26 AWG	28 AWG	30 AWG	Operating Temperature (Note 2)	-40 to +105°C
	2	5A/pin	4A/pin	3.5A/pin	3A/pin	1A/pin	1A/pin	Storage Temperature Range (Note 3)	-10 to +60°C
	3	4A/pin	4A/pin	3.5A/pin	3A/pin			Operating Humidity Range (Note 4)	20 to 80%
	4	4A/pin	3.5A/pin	3A/pin	2.5A/pin			Storage Humidity Range (Note 3)	40 to 70%
	6	3.5A/pin	3A/pin	2.5A/pin	2A/pin				
	9	3.5A/pin	3A/pin	2.5A/pin	2A/pin				
Rated Voltage	250V AC/DC								

UL	Rated Current	See above	Rated Voltage	250V AC/DC	Operating Temperature (Note 2)	-40 to +105°C
C-UL						

UL/C-UL file No.
 UL: E52653
 C-UL: E52653

Items	Specifications	Conditions
Insulation Resistance	1000M Ω Min.	500V DC
Withstanding Voltage	No flashover or insulation breakdown	650V AC for 1 min.
Contact Resistance	30m Ω Max.	20mV Max., 1mA (DC or 1000Hz)
Vibration Resistance	No electrical discontinuity of 1 μs.	10 cycles in each of three directions at frequency 10 to 55Hz, half amplitude 0.75mm
Shock Resistance	No electrical discontinuity of 1 μs.	Accelerated velocity: 490 m/s ² for 11ms, half-sine wave in 3 directions, 3 times for each direction
Humidity Resistance	Contact Resistance: 30m Ω Max. Insulation Resistance: 1000M Ω Min.	96 hours at temperature of +40 ± 2°C and humidity of 90 to 95%
Temperature Cycles	Contact Resistance: 30m Ω Max. Insulation Resistance: 1000M Ω Min.	-55°C : 30 minutes → 5 to 35°C : 2 to 3 minutes → 85°C : 30 minutes → 5 to 35°C : 2 to 3 minutes, 5 cycles
Mating Durability	Contact Resistance: 30m Ω Max.	Tin plating: 30 times Gold plating: 50 times
Solder Heat Resistance	No deformation in appearance or significant damage to contacts.	Flow: 260°C , 10sec. Hand soldering: temperature of soldering iron at 300°C for 3sec.

Note 1: This is the maximum current rating while all pins are powered or used as all power lines.
 When isolating power lines into multiple circuits, current ratings may go above the stated current ratings. Please consult Hirose for details before doing this.

Note 2: Includes temperature rise due to current flow.

Note 3: Applicable to unused items in packed condition.

Note 4: The connector should be completely dry (no condensation present)

Note 5: The panel waterproof type is not UL/C-UL certified.

Note 6: Information contained in this catalog represents general requirements for this Series.
 Contact us for the drawings and specifications for a specific part number shown.

Materials / Finish

Item	Component	Material	Finish	UL Flame Retardant Grade	RoHS2
Socket Crimp Contact	Contact	Phosphorous Bronze	Gold Plating or Tin Plating	-	Yes
Plug Crimp Contact					
Crimp Socket	Insulator	PBT	White or Black	UL94V-0	
Crimp Plug			Black		
Crimp Socket	Seal	Silicone Rubber	Bengala , Gray or Blue	-	
Crimp Plug					
Header	Insulator	PBT	Black	UL94V-0	
	Contact	Brass	Gold Plating or Tin Plating	-	
	Seal	Silicone Rubber	Bengala		

Product Number Structure

Refer to the chart below when determining the product specifications from the product number.
Please select from the product numbers listed in this catalog when placing orders.

Note : The waterproof type (DF62W Series) and non-waterproof type (DF62 Series) are not intermateable.

● Connector (In-line)

DF62WZ # - # EP - 2.2 C

① ② ③ ④ ⑤ ⑥

① Series Name	DF62WZ	④ Connector Type	S: Socket EP: In-line Plug
② Shape Type	None: Regular Type C: Thin Cable Type D: Waterproof Cap	⑤ Contact Pitch	2.2mm
		⑥ Termination Type	C: Crimp Housing
③ No. of Pos.	2, 3, 4, 6, 9		

● Connector (Panel Waterproof In-line)

DF62W P - # EP - 2.2 C

① ② ③ ④ ⑤ ⑥

① Series Name	DF62W	④ Connector Type	EP: In-line Plug
② Shape Type	P: Panel Waterproof In-line	⑤ Contact Pitch	2.2mm
③ No. of Pos.	2, 3, 4, 6	⑥ Termination Type	C: Crimp Housing

● Waterproof Pin

DF62W - WP

① ②

① Series Name	DF62W	② Usage	WP: Waterproof Pin
---------------	-------	---------	--------------------

● Connector (DIP)

DF62WZ - # P - 2.2 DSA (##)

① ② ③ ④ ⑤ ⑥

① Series Name	DF62WZ	④ Contact Pitch	2.2mm
② No. of Pos.	3, 6, 9	⑤ Termination Type	DSA: Straight Pin Header
③ Connector Type	P: Pin Header	⑥ Plating Type	20: Tin Plating 50: Gold Plating

● Contact

DF62W - EP 2226 PCF A

① ② ③ ④ ⑤

① Series Name	DF62W	④ Contact Type / Packaging Type	SCF: Socket Crimp Contact, Reel SC: Socket Crimp Contact, Pieces PCF: Plug Crimp Contact, Reel PC: Plug Crimp Contact, Pieces
② Terminal Type	None: Socket EP: Plug		
③ Applicable Wire Size	2022: 20 to 22 AWG 2226: 22 to 26 AWG 2830: 28 to 30 AWG	⑤ Plating Type	A: Gold Plating None: Tin Plating

Connector Mating Combinations Diagram

Crimp Socket (Note)	Socket Crimp Contact
DF62WZ-#S-2.2C (Standard type)	DF62W-2022SC(F)(A)
DF62WZC-#S-2.2C (Thin cable type)	DF62W-2226SC(F)(A) DF62W-2830SCFA

Note) When using without the crimp contact inserted, fill the contact hole of socket and plug with the DF62W-WP waterproof pin.

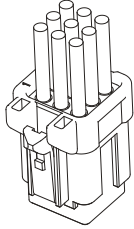

Socket Cap (Note)
DF62WZD#-#S-2.2C

Note) Please use a waterproof cap when waterproof and dustproof is required even when not mating.

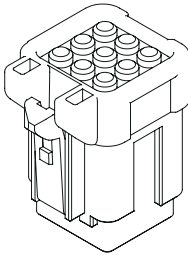

Crimp Plug (Note)	Plug Crimp Contact
DF62WZ-#EP-2.2C (Standard type)	DF62W-EP2022PC(F)(A)
DF62WZC-#EP-2.2C (Thin cable type)	DF62W-EP2226PC(F)(A) DF62W-EP2830PCFA

Note) When using without the crimp contact inserted, fill the contact hole of socket and plug with the DF62W-WP waterproof pin.

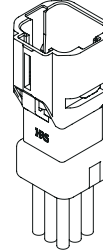

Plug Cap (Note)
DF62WZD-#EP-2.2C

Note) Please use a waterproof cap when waterproof and dustproof is required even when not mating.

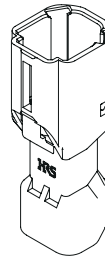

Crimp Plug (Panel Waterproof Type)	Plug Crimp Contact
DF62WP-3/4/6/2EP-2.2C	DF62W-EP2022PC(F)(A) DF62W-EP2226PC(F)(A) DF62W-EP2830PCFA

Note) The compatible sockets are 2,3,4, and 6pos.

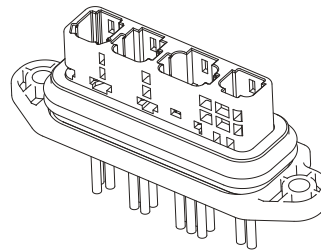

Straight Pin Header
DF62WZ-#P-2.2DSA

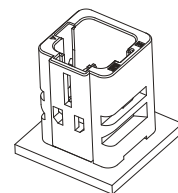

Crimp Socket

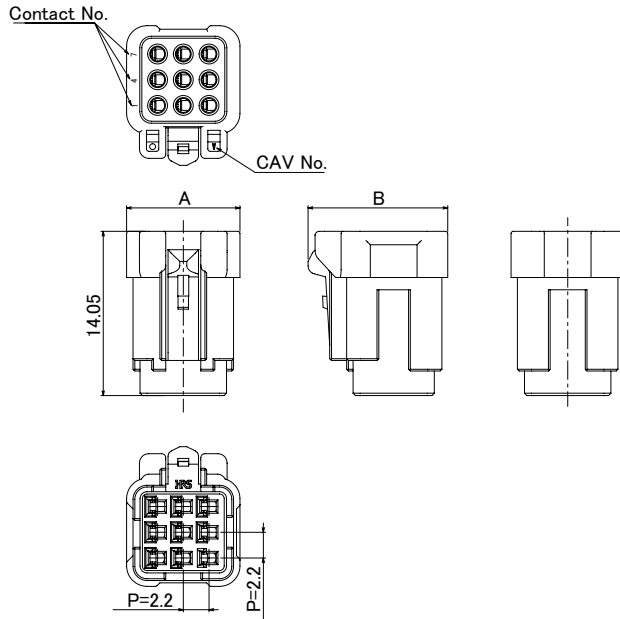

9pos. shown as an example.

Unit : mm

Part No.	HRS No.	No. of Pos.	A	B	Applicable Jacket Outer Diameter	Purchase Unit
DF62WZ-2S-2.2C(##)	CL0544-1102-0-##	2	7.5	7.55	φ 1.4 to 1.6mm	100pcs per bag
DF62WZ-3S-2.2C(##)	CL0544-1103-0-##	3				
DF62WZ-4S-2.2C(##)	CL0544-1104-0-##	4				
DF62WZA-6S-2.2C(11) (Note)	CL0544-1112-0-11	5	9.7	9.75	φ 0.98 to 1.2mm	
DF62WZ-6S-2.2C(##)	CL0544-1105-0-##	6				
DF62WZ-9S-2.2C(##)	CL0544-1106-0-##	9				
DF62WZC-2S-2.2C	CL0544-1107-0-00	2	7.5	7.55	φ 0.98 to 1.2mm	
DF62WZC-3S-2.2C	CL0544-1108-0-00	3				
DF62WZC-4S-2.2C	CL0544-1109-0-00	4				
DF62WZCA-6S-2.2C (Note)	CL0544-1123-0-00	5	9.7	9.75	φ 0.98 to 1.2mm	
DF62WZC-6S-2.2C	CL0544-1110-0-00	6				
DF62WZC-9S-2.2C	CL0544-1111-0-00	9				

(Note) 6pos. rubber insertion hole is filled with 1pin. Can be used as 5pos.

[Specification Number (##), -##]

(00): Mold color White

(11): Mold color Black

■ Crimp Socket External Dimensions

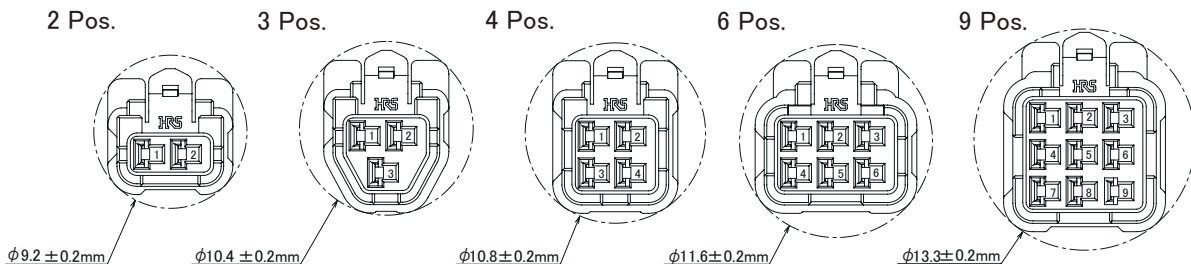

Crimp Plug

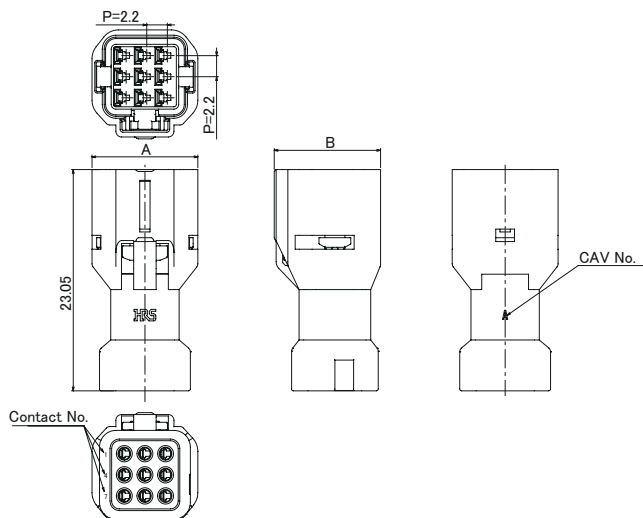

9pos. shown as an example.

Unit : mm

Part No.	HRS No.	No. of Pos.	A	B	Applicable Jacket Outer Diameter	Purchase Unit
DF62WZ-2EP-2.2C	CL0544-1060-0-00	2	7.5	6.7	φ 1.4 ~ 1.6mm	100pcs per bag
DF62WZ-3EP-2.2C	CL0544-1061-0-00	3	8	9.15		
DF62WZ-4EP-2.2C	CL0544-1062-0-00	4	9.1			
DF62WZA-6EP-2.2C (Note)	CL0544-1131-0-00	5	11.3	11.35		
DF62WZ-6EP-2.2C	CL0544-1063-0-00	6				
DF62WZ-9EP-2.2C	CL0544-1064-0-00	9				
DF62WZC-2EP-2.2C	CL0544-1125-0-00	2	7.5	6.7	φ 0.98 ~ 1.2mm	
DF62WZC-3EP-2.2C	CL0544-1126-0-00	3	8	9.15		
DF62WZC-4EP-2.2C	CL0544-1127-0-00	4	9.1			
DF62WZC-6EP-2.2C	CL0544-1128-0-00	6	11.3	11.35		
DF62WZC-9EP-2.2C	CL0544-1129-0-00	9				

(Note) 6pos. rubber insertion hole is filled with 1pin. Can be used as 5pos.

■ Crimp Plug External Dimensions

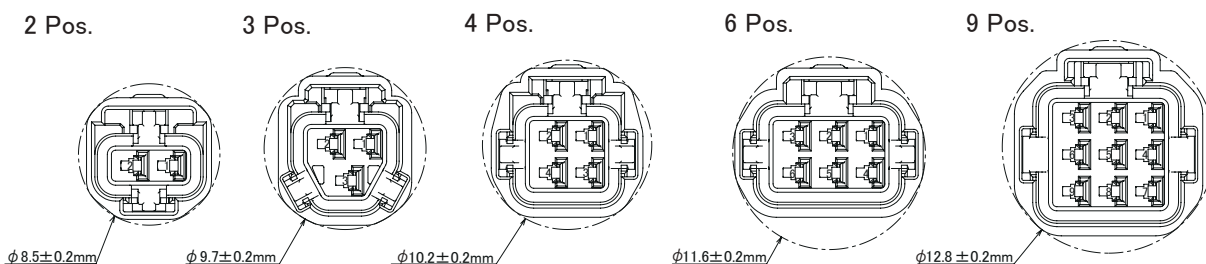

Waterproof Cap



● Socket Cap

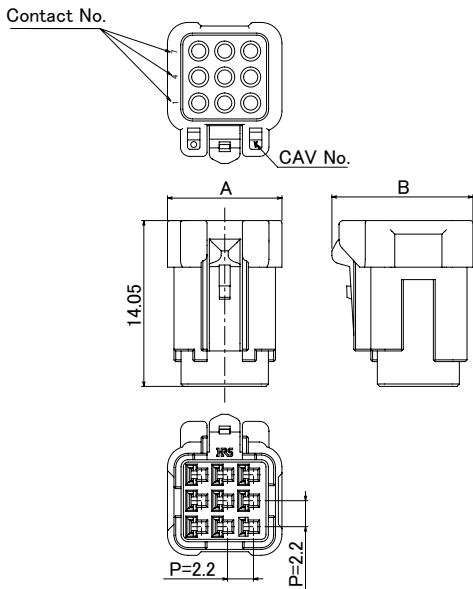

● Plug Cap

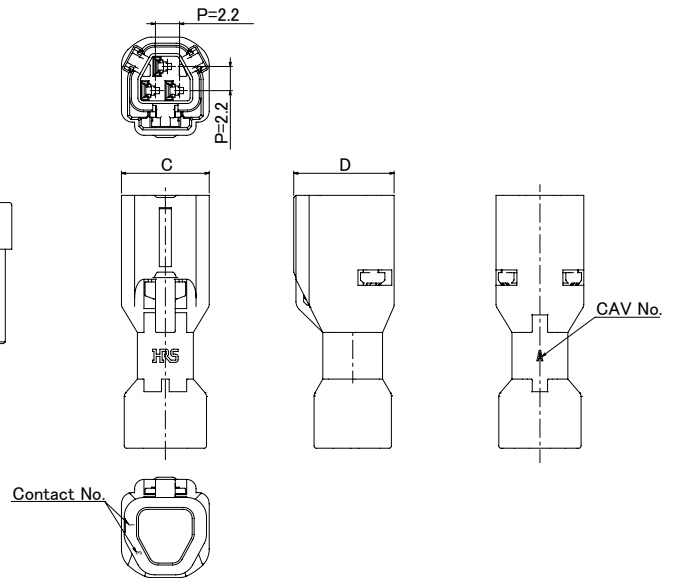

(Note) Figure is an example of the maximum number of positions.

● Socket Cap

Unit : mm

Part No.	HRS No.	No. of Pos.	A	B	Purchase Unit
DF62WDA-6S-2.2C	CL0544-1099-0-00	6	11.3	9.15	100pcs per bag
DF62WZD-9S-2.2C	CL0544-1122-0-00	9	9.7	11.95	

● Plug Cap

Unit : mm

Part No.	HRS No.	No. of Pos.	C	D	Purchase Unit
DF62WZD-2EP-2.2C	CL0544-1133-0-00	2	7.5	6.7	100pcs per bag
DF62WZD-3EP-2.2C	CL0544-1134-0-00	3	8	9.15	

Crimp Plug (Panel Waterproof Type)



Panel-mount waterproof type with integrated 2, 3, 4, and 6pos. configurations. Prevents water ingress from the outside of the housing. The integrated design achieves space savings.

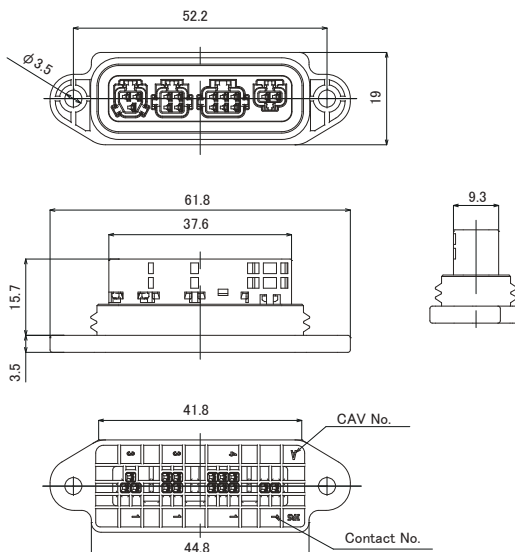

Based on the above diagram, the number of positions for each mating port is as follows from left to right : 3, 4, 6 and 2pos.

Panel Cut-Out Dimensions

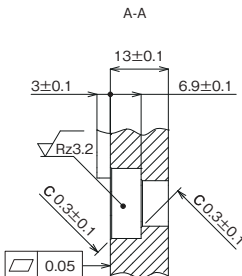
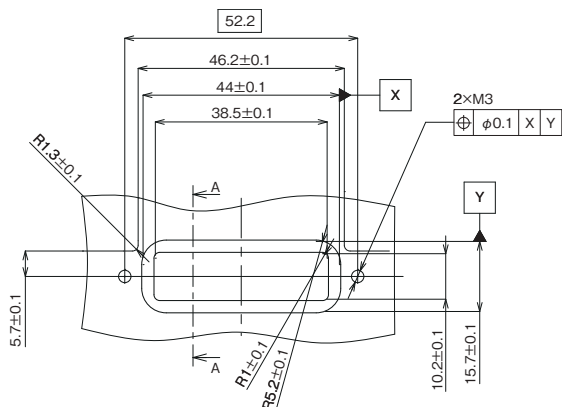

Application Example

[Example] E-Bike Drive Unit

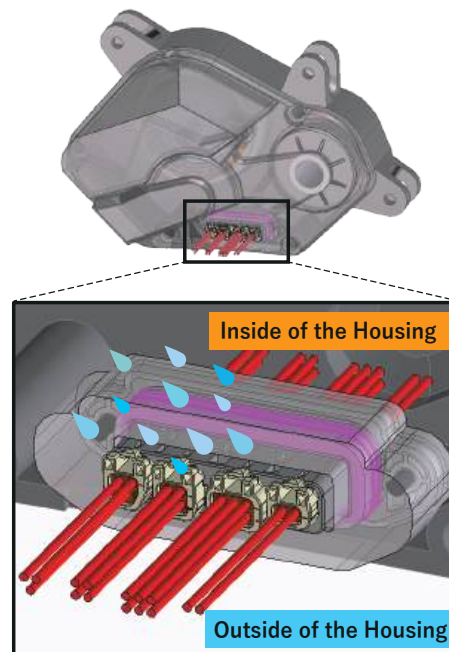

(Note) The interior of the case is not waterproof.

Part No.	HRS No.	No. of Pos.	Applicable Jacket Outer Diameter	Purchase Unit
DF62WP-3/4/6/2EP-2.2C (##)	CL0544-1056-0-##	2/3/4/6	$\phi 0.98$ to 1.2mm $\phi 1.4$ to 1.6mm	24pcs per tray

Note: The panel waterproof type is not UL/C-UL certified.

[Specification Number (##), -##]
(00): Mold color Black
(10): Mold color White

Waterproof Pin

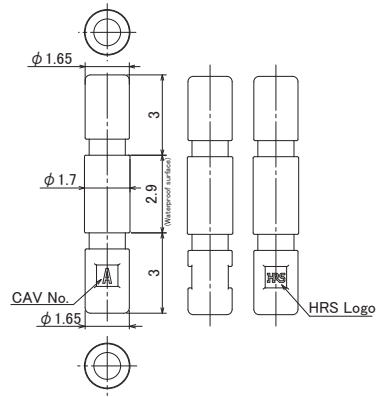

Part No.	HRS No.	Purchase Unit
DF62W-WP	CL0544-1014-6-00	100pcs per bag

Note 1 : When using without the crimp contact inserted, fill the contact hole of socket and plug with a waterproof pin.

Note 2 : Both standard type and thin wire type can be used.

Note 3 : Not compatible with the panel waterproof type.

Straight Pin Header

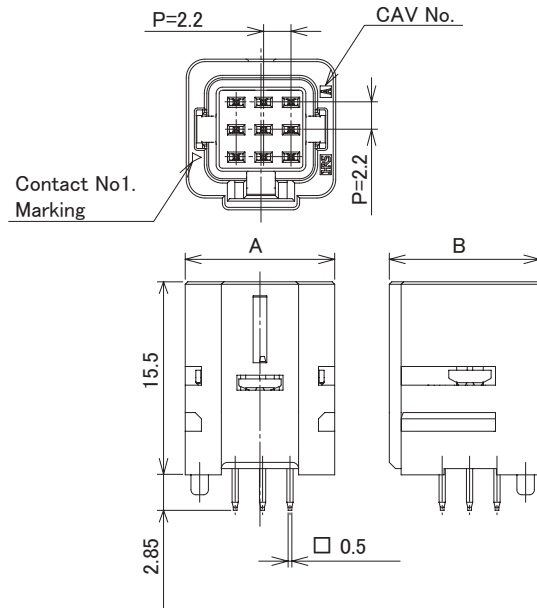

9pos. shown as an example.

Unit : mm

Part No.	HRS No.	No. of Pos.	A	B	Purchase Unit
DF62WZ-3P-2.2DSA(##)	CL0544-1055-0-##	3	8.7	9.5	256pcs per tray
DF62WZ-6P-2.2DSA(##)	CL0544-1059-0-##	6	12	9.9	240pcs per tray
DF62WZ-9P-2.2DSA(##)	CL0544-1050-0-##	9	12	12.1	200pcs per tray

(Note) Potting is required when using. Potting height: 1 to 5mm

[Specification No. (##),-##]

(20): Tin plating

(50): Gold plating

Recommended PCB Layout (Recommended Thickness $t=1.6\pm 0.1$)

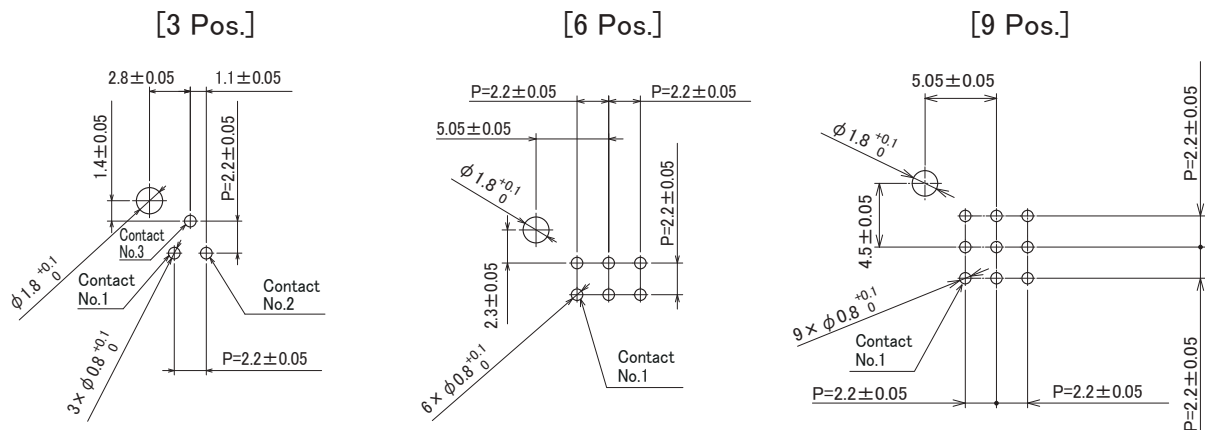

Socket Crimp Contact

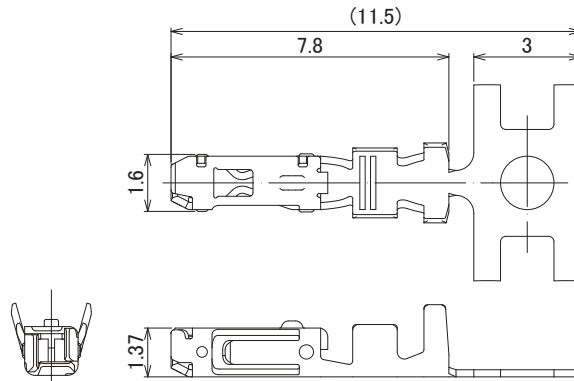
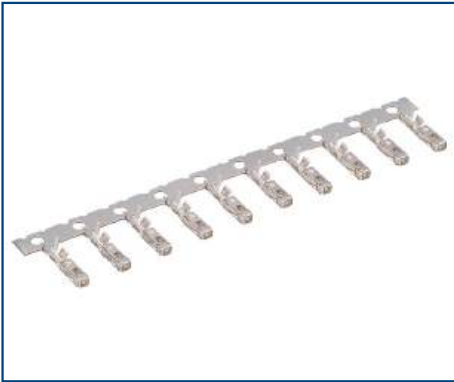

● Reel Contact, Applicable Tool : Applicator

Part No.	HRS No.	Finish	Applicable Wire (Tin Plated Annealed Copper) (Note)					Compatible Connector	Purchase Unit
			UL	AWG	Stranded Wire Structure	Calculated Cross-section	Jacket Diameter		
DF62W-2022SCF DF62W-2022SCFA	CL0544-1015-9-00 CL0544-1027-0-00	Tin Plated Gold Plated	3443	20	7/0.32mm	0.563mm ²	φ 1.4 to φ 1.6mm	DF62WZ-#S-2.2C	15,000pcs per reel
			1007	22	17/0.16mm	0.342mm ²			
DF62W-2226SCF DF62W-2226SCFA	CL0544-1000-1-00 CL0544-1025-0-00	Tin Plated Gold Plated	1007	22	17/0.16mm	0.342mm ²			
				24	11/0.16mm	0.221mm ²			
			1430	26	7/0.16mm	0.141mm ²			
DF62W-2830SCFA	CL0544-1038-0-00	Gold Plated	1061	24	11/0.16mm	0.221mm ²	φ 0.98 to φ 1.2mm	DF62WZC-#S-2.2C	
				26	7/0.16mm	0.141mm ²			
DF62W-2830SCFA	CL0544-1038-0-00	Gold Plated	1007	28	7/0.127mm	0.089mm ²	φ 0.98 to φ 1.2mm	DF62WZC-#S-2.2C	
				30	7/0.1mm	0.055mm ²			

Note 1 : For applicable cable other than those listed above, refer to Crimp Condition Table. Crimp Condition Table is available from Part No. link.

(If you are using a cable that is not listed in Crimp Condition Table, please contact a Hirose sales representative.)

Note 2 : There are cases in which use of a flexible wire (thin, stranded conductor or soft jacket material) may make insertion to socket difficult. Please contact a Hirose representative for more information.

● Loose Piece, Applicable Tool : Hand Crimping Tool

Part No.	HRS No.	Finish	Applicable Wire (Tin Plated Annealed Copper) (Note)					Compatible Connector	Purchase Unit
			UL	AWG	Stranded Wire Structure	Calculated Cross-section	Jacket Diameter		
DF62W-2022SC DF62W-2022SCA	CL0544-1017-4-00 CL0544-1045-0-00	Tin Plated Gold Plated	3443	20	7/0.32mm	0.563mm ²	φ 1.53mm	DF62W-#S-2.2C	100pcs per bag
			1007	22	17/0.16mm	0.342mm ²	φ 1.58mm		
DF62W-2226SC DF62W-2226SCA	CL0544-1012-0-00 CL0544-1044-0-00	Tin Plated Gold Plated	1007	22	17/0.16mm	0.342mm ²	φ 1.58mm		
				24	11/0.16mm	0.221mm ²	φ 1.42mm		
			1430	26	7/0.16mm	0.141mm ²	φ 1.48mm		

Note : The applicable cables include only those listed above.

Plug Crimp Contact

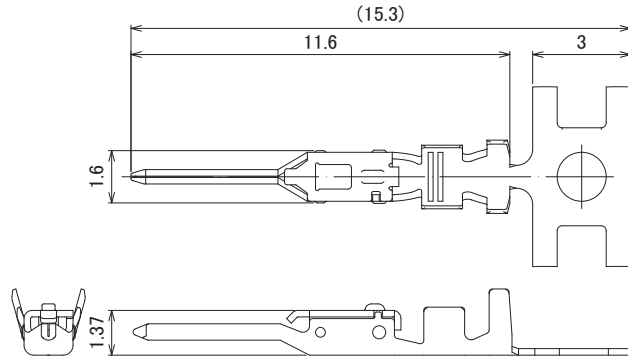

● Reel Contact, Applicable Tool : Applicator

Part No.	HRS No.	Finish	Applicable Wire (Tin Plated Annealed Copper) (Note 1)					Compatible Connector	Purchase Unit
			UL	AWG	Stranded Wire Structure	Calculated Cross-section	Jacket Diameter		
DF62W-EP2022PCF DF62W-EP2022PCFA	CL0544-1016-1-00 CL0544-1028-0-00	Tin Plated Gold Plated	3443	20	7/0.32mm	0.563mm ²	φ 1.4 to φ 1.6mm	DF62WZ-#EP-2.2C DF62WP-3/4/6/2EP-2.2C	15,000pcs per reel
			1007	22	17/0.16mm	0.342mm ²			
DF62W-EP2226PCF DF62W-EP2226PCFA	CL0544-1001-4-00 CL0544-1026-0-00	Tin Plated Gold Plated	1007	22	17/0.16mm	0.342mm ²			
				24	11/0.16mm	0.221mm ²			
			1430	24	11/0.16mm	0.221mm ²			
				26	7/0.16mm	0.141mm ²			
DF62W-EP2830PCFA	CL0544-1039-0-00	Gold Plated	1007	28	7/0.127mm	0.089mm ²	φ 0.98 to φ 1.2mm	DF62WZC-#EP-2.2C	
				30	7/0.1mm	0.055mm ²			

Note 1 : For applicable cable other than those listed above, refer to Crimp Condition Table. Crimp Condition Table is available from Part No. link.

(If you are using a cable that is not listed in Crimp Condition Table, please contact a Hirose sales representative.)

Note 2 : There are cases in which use of a flexible wire (thin, stranded conductor or soft jacket material) may make insertion to socket difficult. Please contact a Hirose representative for more information.

● Loose Piece, Applicable Tool : Hand Crimping Tool

Part No.	HRS No.	Finish	Applicable Wire (Tin Plated Annealed Copper) (Note)					Compatible Connector	Purchase Unit
			UL	AWG	Stranded Wire Structure	Calculated Cross-section	Jacket Diameter		
DF62W-EP2022PC DF62W-EP2022PCA	CL0544-1018-7-00 CL0544-1043-0-00	Tin Plated Gold Plated	3443	20	7/0.32mm	0.563mm ²	φ 1.53mm	DF62WZ-#EP-2.2C DF62WP-3/4/6/2EP-2.2C	100pcs per bag
			1007	22	17/0.16mm	0.342mm ²	φ 1.58mm		
DF62W-EP2226PC DF62W-EP2226PCA	CL0544-1013-3-00 CL0544-1042-0-00	Tin Plated Gold Plated	1007	22	17/0.16mm	0.342mm ²	φ 1.58mm		
				24	11/0.16mm	0.221mm ²	φ 1.42mm		
			1430	26	7/0.16mm	0.141mm ²	φ 1.48mm		

Note : The applicable cables include only those listed above.

Mated Dimensions

● Wire-to-Wire Connection

【Standard, Thin Wire Compatible Type】

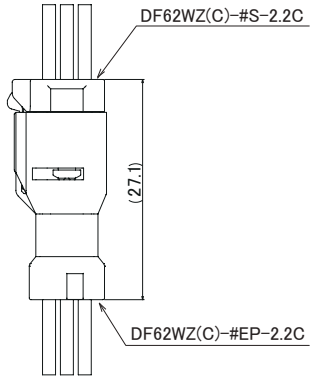

【Panel Waterproof Type】

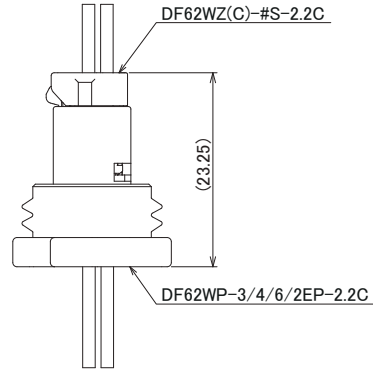

● Mated Condition Diameter

2 Pos.

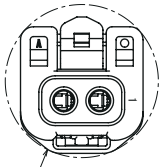

3 Pos.

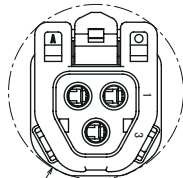

4 Pos.

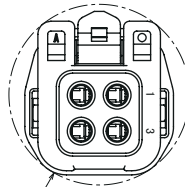

6 Pos.

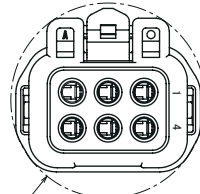

9 Pos.

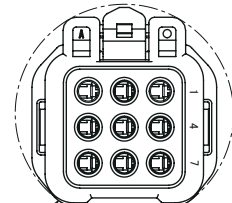

● Wire-to-Board Connection (Straight Pin Header)

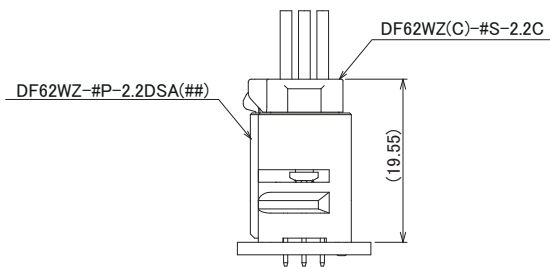

Applicable Crimping Tools

Tool	Part No.	HRS No.	Applicable Contact
Applicator	AP105-DF62W-2022	CL0901-4500-0-00	DF62W-2022SCF(A) DF62W-EP2022PCF(A)
	EHS899800H-UP (Note 2)	-	
	AP105-DF62W-2226	CL0901-4637-0-00	DF62W-2226SCF(A) DF62W-EP2226PCF(A)
	EHS888400H-UP (Note 2)	-	
	AP105-DF62W-2830	CL0901-4650-0-00	DF62W-2830SCFA DF62W-EP2830PCFA
Press Body	CM-105C	CL0901-0001-0-00	-
Hand Tool	HT802/DF62W-2022 (Note 4)	CL0550-0431-0-00	DF62W-2022SC(A) DF62W-EP2022PC(A)
	HT802/DF62W-2226 (Note 5)	CL0550-0416-6-00	DF62W-2226SC(A) DF62W-EP2226PC(A)
Extraction Tool	DF62W/RE-MD	CL0902-4666-4-00	DF62W-2022SC(F)(A) DF62W-EP2022PC(F)(A) DF62W-2226SC(F)(A) DF62W-EP2226PC(F)(A) DF62W-2830SCFA DF62W-EP2830PCFA

Note 1 : Issues with non-Hirose specified tools are outside the scope of warranty.

Note 2 : Applicator manufactured by JAPAN AUTOMATIC MACHINE(J.A.M.).

Please contact J.A.M. via the URL below regarding inquiries on the applicator or crimp defects.

(URL : <http://www.jam-net.co.jp>)

Note 3 : Please conduct crimping work according to the "Crimping Quality Standard" and "Crimping Condition Table".

Note 4 : The compatible wire is limited to UL3443 (20 AWG) or UL1007 (22 AWG).

Note 5 : The compatible wire is limited to UL1007 (22 to 24 AWG) or UL1430 (24 to 26 AWG).

Note 6 : When using non-Hirose specified tools,

please consult with a Hirose sales representative regarding requests for the tool die drawing.

Crimping

■ Items Required Prior to Starting

The work-related documents listed below are required before starting harness assembly.

(The ● mark indicates a required document.)

When the documents shown below are not available, ask a Hirose sales personnel to provide them.

Document Title	Description	Automatic Crimping Machine	Hand Crimping Tool	Remarks
(1) Main Unit of Crimping Machine Instruction Manual	Explanation of main press machine unit	●	-	Bundled with the purchase of the main press machine unit.
(2) Applicator Spare Parts Identification	Explanation for Applicator installation	●	-	
(3) Crimp Conditions	Standard values of : Crimp height, tensile strength	●	-	Bundled with the purchase of applicator.
(4) Crimp Quality Standards	Various standards for crimping conditions	●	-	
(5) Operating Instructions for Hand Tool	Inspection items of : Crimp height, tensile strength, other	-	●	Bundled with the purchase of hand tool.
(6) DF62W Series Cable Assembly	Cable assembly procedure	●	●	Please refer to our website.

■ Tools

Use tools designated by Hirose when crimping.

·Crimping performed using tools other than those specified is outside the scope of warranty.

·The operating instructions manual is available for the crimping machine and the applicator. Be sure to carefully read the operating instructions manual before implementing the work.

■ Applicable Electric Wires

Refer to Crimp Condition Table when using cables other than applicable wire. Crimp Condition Table is available from Part No. link.

(If you are using a cable that is not listed in Crimp Condition Table, please contact a Hirose sales representative.)

[Precautions]

- Electric wires that are suitable for crimping connectors are tin-plated stranded soft copper wire.
- Avoid crimping solid wires, wires with polyester threads or tin-coated wires.
- Avoid crimping two electric wires together.
- The crimp height setting value (Note) may vary between tin-plated and gold-plated contacts even if the same electric wires are used.
- The crimp height setting value (Note) may vary depending on the difference in the core wire configuration even if the computed cross-sectional area is the same.

Note : The crimp height is an important item that determines crimping quality. We execute crimping tests for each electric wire to ensure the optimal value for the crimp height with high precision, thereby ensuring optimal setup values.

Precautions

1.Cleaning Conditions	Please refer to the "Wire-to-Board Connector Guide ". Cleaning with IPA is allowed. (Other cleaning agents are not recommended due to the fact that it may change the push/pull feeling. Please contact us when you use other cleaning agents.)
2.Important Notes	<ol style="list-style-type: none"> 1. Caution is required for mating and un-mating the connector without it being mounting on a PCB. Doing so can damage or deform the contacts. 2. During hand soldering, do not apply excess amounts of flux which can migrate onto the connector. 3. This product may have a slight differences in color depending on the production lot. This difference does not have any influence on the performance. 4. Black spots may appear on the mold resin but this does not affect the product quality.
3.Handling Instructions	<p>Please refer to the materials listed below on our company website when handling this product.</p> <ul style="list-style-type: none"> ■ Product Guidelines (Board-to-Wire Connector Guidelines) ■ Product Guidelines (Mating/Unmating Operation Instruction Manual) ■ Cable Assembly Instruction ■ Crimp Quality Standard

While Taking into Consideration

Specifications mentioned in this catalog are reference values.

When considering to order or use this product, please review the Drawing and Product Specifications sheets.

Use an appropriate cable when using the connector in combination with cables.

If considering usage of a non-specified cable, please contact your sales representative.

If assembly process is done by jigs & tools which are not identified by Hirose, the warranty of the product may be affected.

If considering usage for below mentioned applications, please contact your sales representative.

In cases where the application will demand a high level of reliability, such as automotive, medical instruments, public infrastructure, aerospace/ defense etc. Hirose must review before assurance of reliability can be given.