

B, K & T Series Multipole connectors

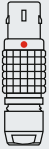

LEMO Solutions Portfolio



1 ORIGINALS

Your configurable solution

- Self-Latching Push-Pull locking
- Wide & modular range
- Broad application reach
- Indoor & outdoor

Series	B, K, T
	S, E



2 REDEL

Your trusted medical solution

- Medical and Industrial grade plastics
- Device ergonomics
- Electrical safety
- High density & modularity

Series	P
	SP
	MP



3 OPTIMA

Your optimised solution

- Compact & miniature
- Lightweight & low-profile
- High vibration resistance
- IP68 & MIL-STD tested

Series	M
	F
	D



4 SUPREME

Your extreme solution

- High/Low pressure
- Radiation & corrosion
- High Voltage
- Regulated environments

Series	N
	W
	Y

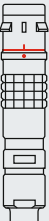

5 SPECIALTIES

Your specialised solution

- Industry standards
- Special configurations
- Historical products

Series	3K.93C.Y, 00 Nim-Camac
	V, 2G/2C, R, ...



6 CABLES

Your unique cable solution

- Design expertise
- In house prototype to production
- Custom cables
- Conductive & hybrid

Series	Technical cables
	Biocompatibility
	Automation & high-flex
	Retractable coil cords
	Ruggedised

SERVICES

Cable assembly services (single-end, double-end, custom harness, overmolding, ...)

Custom solution (connector, cable, device)

Signal integrity end-to-end services

Understanding LEMO's product selection benefits:

Standard versus Special.

LEMO has a +80 years history of developing custom connectivity solutions. Our very broad offering of models combined with our modular insert design results in a range of over 90'000 connector solutions. This vast product portfolio enables you to select the ideal connector configuration to suit almost any specific requirement in the most demanding markets, including yours.

In this product catalogue we have structured our product offering into two categories:

- **STANDARD** products (in blue) – Most commonly used products for which we can ensure the best availability and shorter lead times. For these products a 10 pcs minimum order quantity (MOQ) applies.
- **SPECIAL** products (in orange) – More niche products designed for customers with specific requirements. For these products a higher minimum order quantity (MOQ) will apply, prices might be higher and lead times are typically longer.

And this differentiation between **STANDARD** and **SPECIAL** applies on three different levels:

1. **MODEL** – Outershell / Backshell shape
2. **KEYING** – Alignment key for differentiated mating
3. **SIZE** – Physical dimensions of the connector

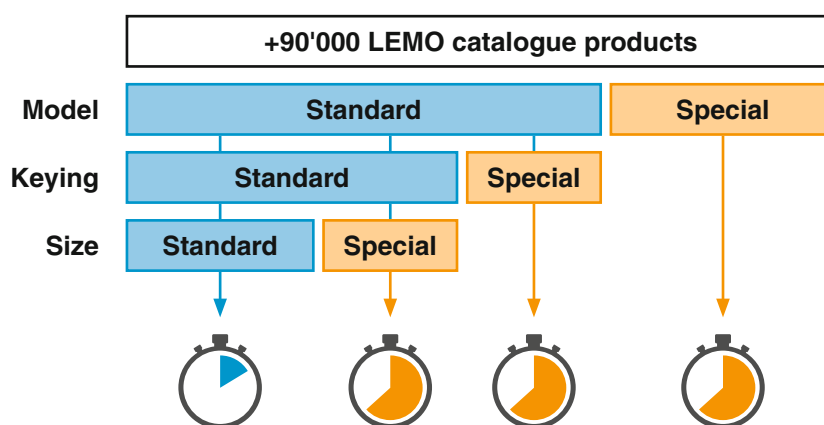

Only if Model + Keying + Size are all within the STANDARD product offering, you will have the best availability and shorter lead time. We recommend you find as much as possible the right solution for your connectivity challenge within our standard product offer.

For all other, special products, we recommend you contact your local LEMO representative to discuss your overall project's life span and long-term needs, so we can align your forecast with applicable MOQ quantities.

By clearly distinguishing between Standard and Special products, LEMO ensures maximum flexibility while still offering the perfect solution to fully meet our customer needs.

Precision modular connectors to suit your application

Since its creation in Switzerland in 1946 the LEMO Group has been recognized as a global leader of circular Push-Pull connectors and connectivity solutions. Today LEMO Group is active in more than 80 countries with the help of over 40 subsidiaries and distributors.

Over 90000 connectors

The modular design of the LEMO range provides over 90000 connectors from miniature \varnothing 3 mm to large size \varnothing 50 mm, handling cable diameters up to 30 mm and for up to 114 contacts in a single connector. This vast portfolio enables you to select the ideal connector configuration to suit almost any specific requirement in most markets, including medical devices, test and measurement instruments, industrial and machinery, audio video broadcast, semi conductor, energy, telecommunications, motorsport, security and defence.

LEMO's Push-Pull Self-Latching Connection System

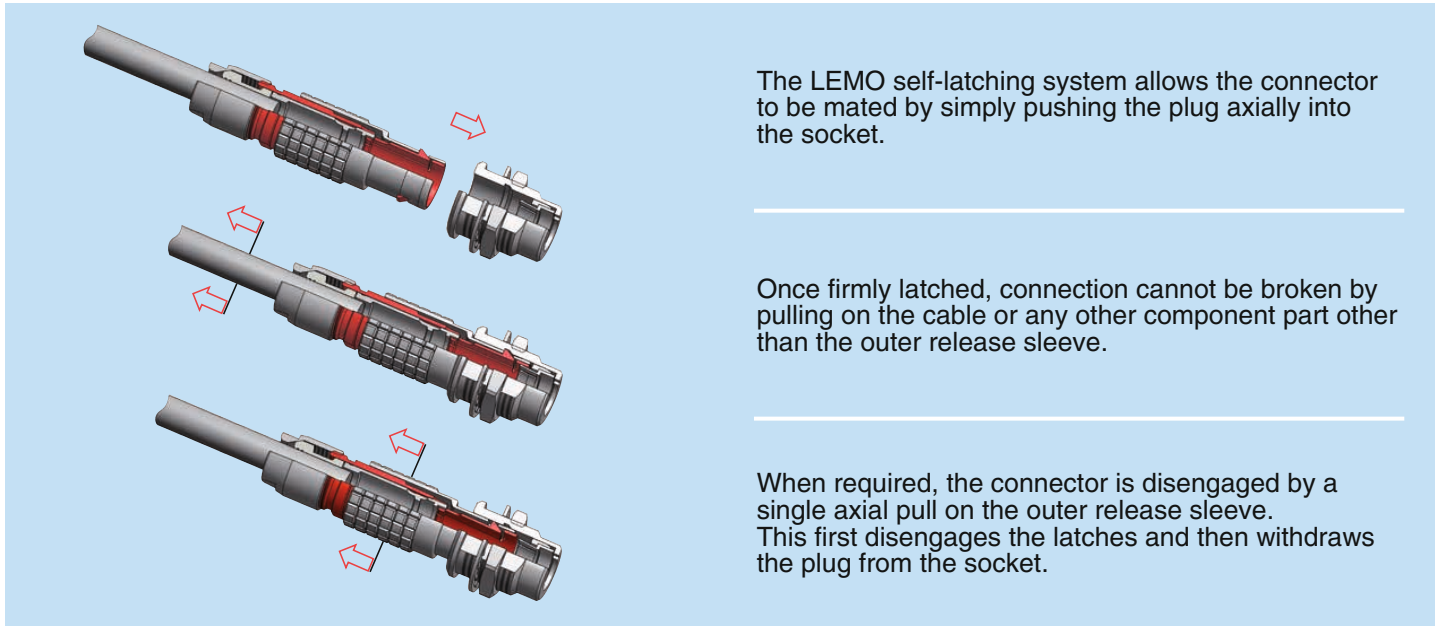

This self-latching system is renowned worldwide for its easy and quick mating and unmating features. It provides absolute security against vibration, shock or pull on the cable, and facilitates operation in a very limited space.



UL Recognition

LEMO connectors are recognized by the Underwriters Laboratories (UL). The approval of the complete system (LEMO connector, cable and your equipment) will be easier because LEMO connectors are recognized.

CE marking

CE marking  means that the appliance or equipment bearing it complies with the protection requirements of one or several European safety directives. CE marking  applies to complete products or equipment, **but not to electromechanical components, such as connectors.**

RoHS

LEMO connector specifications conforms the requirements of the RoHS directive (2011/65/EU) of the European Parliament and the latest amendments. This directive specifies the restrictions of the use of hazardous substances in electrical and electronic equipment marketed in Europe.

Product safety notice & disclaimers

Please read and follow all instructions specified on the last page or on our [website](#) carefully and consult all relevant national and international safety regulations for your application. Improper handling, cable assembly, or wrong use of connectors can result in hazardous situations.

LEMO products and services are provided "as is." LEMO makes no warranties or representations with regard to LEMO product & services or use of them, express, implied or statutory, including for accuracy, completeness, or security.

In no event shall LEMO be liable for any direct, indirect, punitive, incidental, special consequential damages, to property or life, whatsoever arising out of or connected with the use or misuse of LEMO's products.

Table of contents

LEMO's Push-Pull self-latching system	4
ORIGINALS's B, K & T series	6
Select connector series	7
Definition of Ingress Protection (IP code)	8
Selection of connectors for watertight or vacuumtight devices	8
B series:	
Standard models interconnections	10
Part section showing internal components	10
Special models interconnections	11
Standard part numbering system	12
Standard models	13
Watertight or vacuumtight models	22
Elbow socket models	25
Special models	28
Watertight or vacuumtight models	31
Elbow socket models	33
Threaded-latching models	34
Bridge models	35
Plastic housing models	36
Alignment key and polarized keying system	38
K series:	
Standard models interconnections	40
Part section showing internal components	40
Special models interconnections	41
Standard part numbering system	42
Standard models	43
Watertight or vacuumtight models	48
Elbow socket models	49
Special models	50
Watertight or vacuumtight models	54
Alignment key and polarized keying system	56
T series:	
Standard models interconnections	58
Part section showing internal components	58
Special models interconnections	59
Standard part numbering system	60
Standard models	61
Watertight or vacuumtight models	64
Special models	65
Watertight or vacuumtight models	66
Plastic housing models	67
Alignment key and polarized keying system	68
B, K, T series:	
Multipole insert configuration	70
Mixed insert configuration	76
Housings, insulators, contacts	77
Collets	80
Variant	84
Spare parts	88
Accessories	98
Tooling	111
Panel cut-outs and PCB drilling pattern	117
Cable assembly	124
Technical characteristics	130
Product safety notice & Disclaimers	4, 143

ORIGINALS B, K & T Series

Broad and modular, configurable solutions for indoor and outdoor

ORIGINALS B, K & T Series make up the historical modular highly configurable range of original Push-Pull connectors and offer exceptional scalability spanning from ultra-miniature to larger sizes.

Providing an unmatched quick and easy to use mating system for demanding applications in a very wide variety of markets and extreme working conditions indoor and outdoor.

The cylindrical shape enables a wide range of body styles, materials and configurations from low to high voltage, multi-pin and mixed configurations, equally suitable for high-speed data, signal, power and other applications.

Large choice of sizes (up to 8) from ultra-miniature to very large, fitting cables from 1.0 mm up to 25 mm

Robust multi-keying system

Large choice of straight and angled plug models

Push-Pull self-latching system for quick and easy mating and un-mating

Large choice of front or back mounted sockets models

Extensively tested, highest quality and reliability

Modular inserts with low to high voltage, multi-pin (up to 64) and mixed configurations



Select connector series

LEMO multiple connectors

The characteristic feature of these connector series is a keying system which allows higher contact density and prevents all errors in alignment. The various keying alternatives prevent unwanted cross mating of otherwise similar connectors. All the 3 series (B, K, T) use the same contact inserts insulator configuration.

The standard keyed series (B, 00)

These connector series, include the 0B to 5B range as well as the 00 multipole, some vacuumtight models are also available.

The watertight keyed series (K)

These series are watertight when mated and assembled to an appropriate cable. They include sizes from the 0K to 5K series.

The watertight miniature keyed series (T)

These series are watertight when mated and assembled to an appropriate cable. They include sizes from the TT to 3T series.

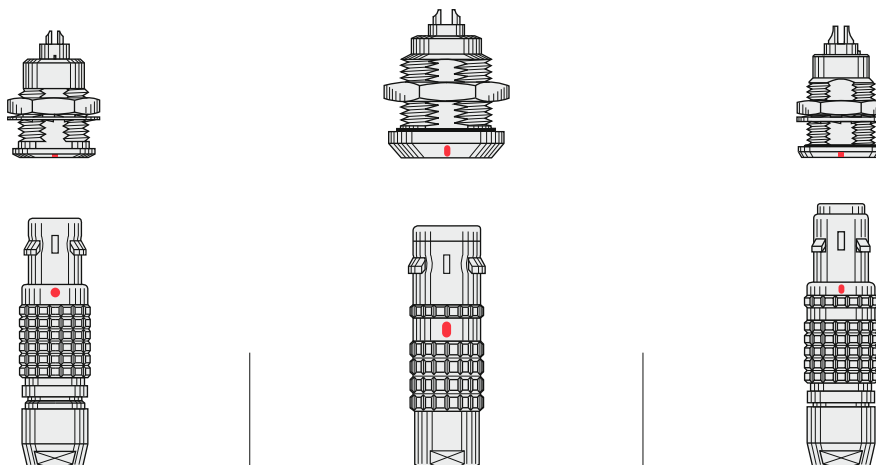

Series	00 multipole B	K	T
Environment	indoor	outdoor or harsh environment	outdoor miniature
Ingress protection ¹⁾	IP50	IP66 to IP68	
Ingress protection ²⁾	IP50 to IP68 vacuumtight	IP66 to IP68 vacuumtight	
Temperature range	- 55 to 250°C ³⁾	- 55 to 200°C	
Latching	Push-Pull self-latching		
Shell sizes	8 metal and 4 plastic	6 metal	5 metal and 2 plastic
Insulator type	Multipole (page 68)		
Contact type	Solder, crimp or print		
Features	7 keyways	6 keyways	5 keyways
Page	9 to 38	39 to 56	57 to 68

Note:

¹⁾ Mated connector. See ingress protection code page 8.

²⁾ Your device. For selection of connectors for watertight and vacuumtight devices, see page 8.

³⁾ Maximum temperature valid for short periods of use.

Definition of Ingress Protection (IP code)

IEC 60529 outlines an international classification system for the sealing effectiveness of enclosures of electrical equipment against the intrusion into the equipment of foreign bodies (i.e. tools, dust, fingers) and moisture. This classification system utilizes the letters «IP» (Ingress Protection) followed by two digits.

Example: IP 50 = IP 5 0

IP letter code _____
 1st digit _____
 2nd digit _____

Degrees of protection - First digit

The first digit of the IP code indicates the degree to which persons are protected against contact with moving parts and the degree that equipment is protected against solid foreign bodies intruding into an enclosure.

Code	First digit description
0	No special protection
1	Protection from a large part of the body such as hand or from solid objects greater than 50 mm in diameter
2	Protection against objects not greater than 80 mm in length and 12 mm in diameter
3	Protection from entry by tools, wires, etc., with a diameter or thickness greater than 2.5 mm
4	Protection from entry by solid objects with a diameter or thickness greater than 1.0 mm
5	Protection from the amount of dust that would interfere with the operation of the equipment
6	Dust-tight
7	–
8	–

Degrees of protection - Second digit

The second digit indicates the degree of protection of the equipment inside the enclosure against the harmful entry of various forms of moisture (e.g. dripping, spraying, submersion, etc.)

Code	Second digit description
0	No special protection
1	Protection from vertically dripping water
2	Protection from dripping water when tilted up to 15°
3	Protection from sprayed water
4	Protection from splashed water
5	Protection from water projected from a nozzle
6	Protection against heavy seas, or powerful jets of water
7	Protection against temporary immersion
8	Protection against complete continuous submersion in water

Selection of connectors for watertight or vacuumtight devices

LEMO B series is rated IP50 only when mated. LEMO K and T series are rated IP66 (and over) only when mated. If a device must be watertight or vacuumtight when the connectors are unmated, it is important to select a watertight or vacuumtight socket. You can consider the following two situations:

A) Figure 1 shows a typical outdoor device. To ensure this device retains IP66 or above when connectors are unmated, it is important to choose a watertight socket from B, K or T series.

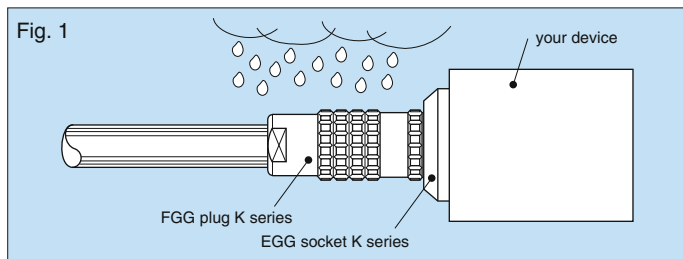

B) Figure 2 shows a device which is subjected to pressure difference such as a near vacuum or pressurized gas and must exhibit no leakage. To ensure the device maintains its sealing, the socket is additionally tested for helium leakage (according to MIL 1344A).

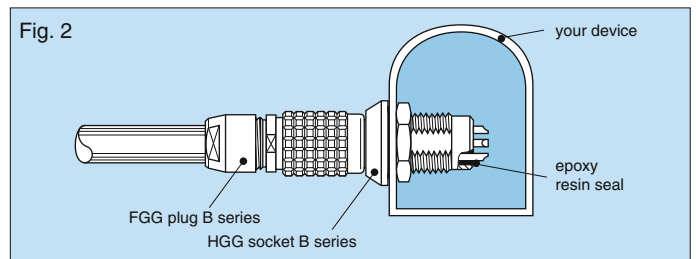

Check temperature range (see section on pages 22, 48 and 64).

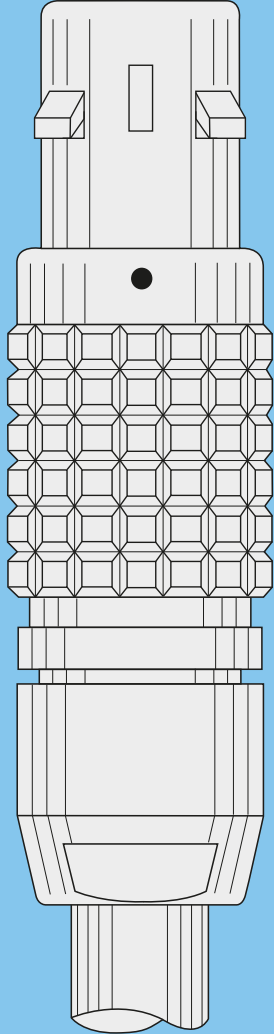
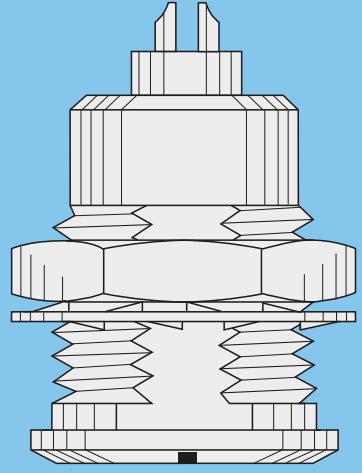

B SERIES

B Series

B series connectors provide the following main features:

- security of the Push-Pull self-latching system
- solder, crimp or print contacts (straight or elbow)
- multiple key options to avoid cross mating of similar connectors
- 360° screening for full EMC shielding.
- multipole types 2 to 64 contacts
- high packing density for space savings
- keying system («G» key standard) for connector alignment

B series (standard models)

Standard models (page 13)

Elbow plugs

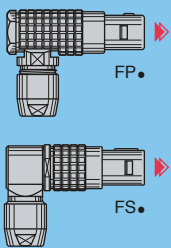

Fixed plugs

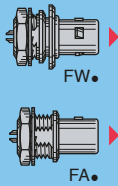

Straight plugs

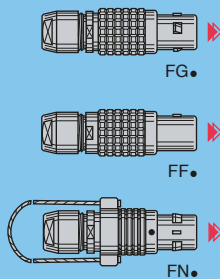

Sockets

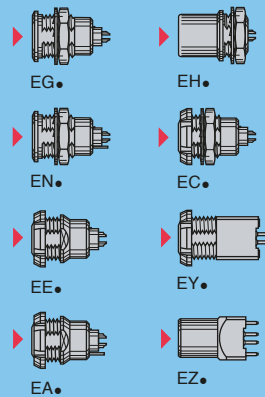

Free cable socket

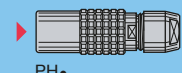

Fixed cable socket

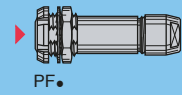

Fixed coupler

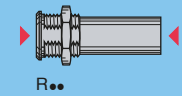

Watertight or vacuumtight models (page 22)

Sockets

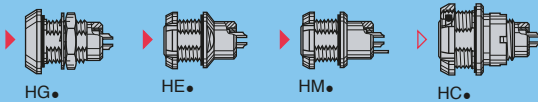

Fixed coupler

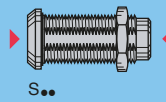

Elbow socket models (page 25)

Elbow sockets

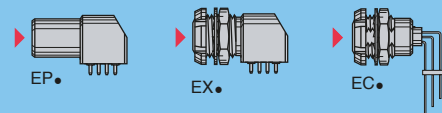

Part section showing internal components

Fixed socket

- 1 outer shell
- 2 earthing crown
- 3 retaining ring
- 4 hexagonal nut
- 5 locking washer
- 6 insulator
- 7 female contact

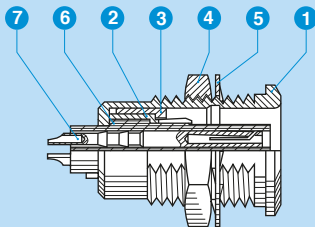

Straight plug

- 1 outer shell
- 2 latch sleeve
- 3 collet nut
- 4 split insert carrier
- 5 insulator
- 6 male contact
- 7 collet

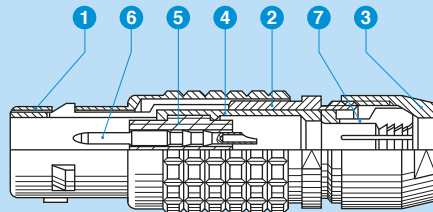

B series (special models)

Special models (page 28)

Elbow plugs

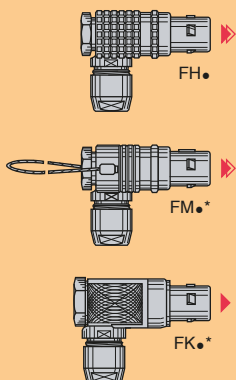

Straight plugs

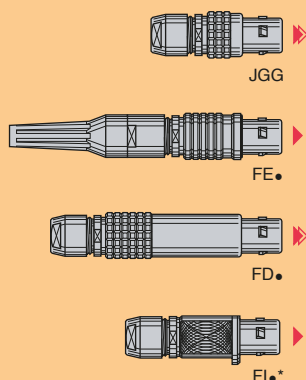

Sockets

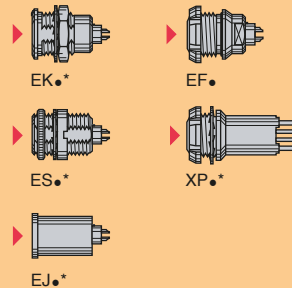

Free cable socket

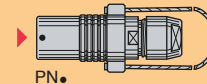

Fixed cable sockets

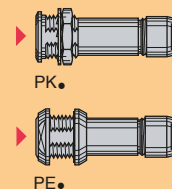

Elbow socket model (page 33)

Elbow socket

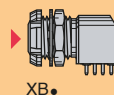

Watertight or vacuumtight models (page 31)

Fixed plug

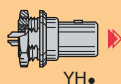

Sockets

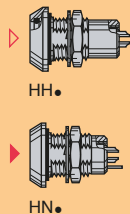

Threaded-latching models (page 34)

Straight plugs

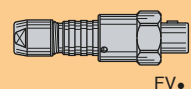

Socket



Elbow socket

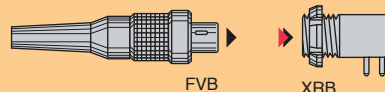

Bridge models (page 35)

Bridge plugs

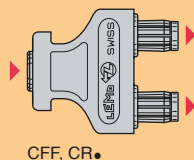

Plastic housing models (page 36)

Straight plugs

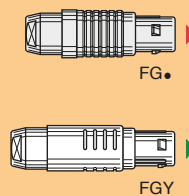

Sockets

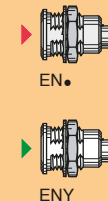

Note: * Check product finder LEMO.COM for details.

Part numbering system

Standard models part numbering system

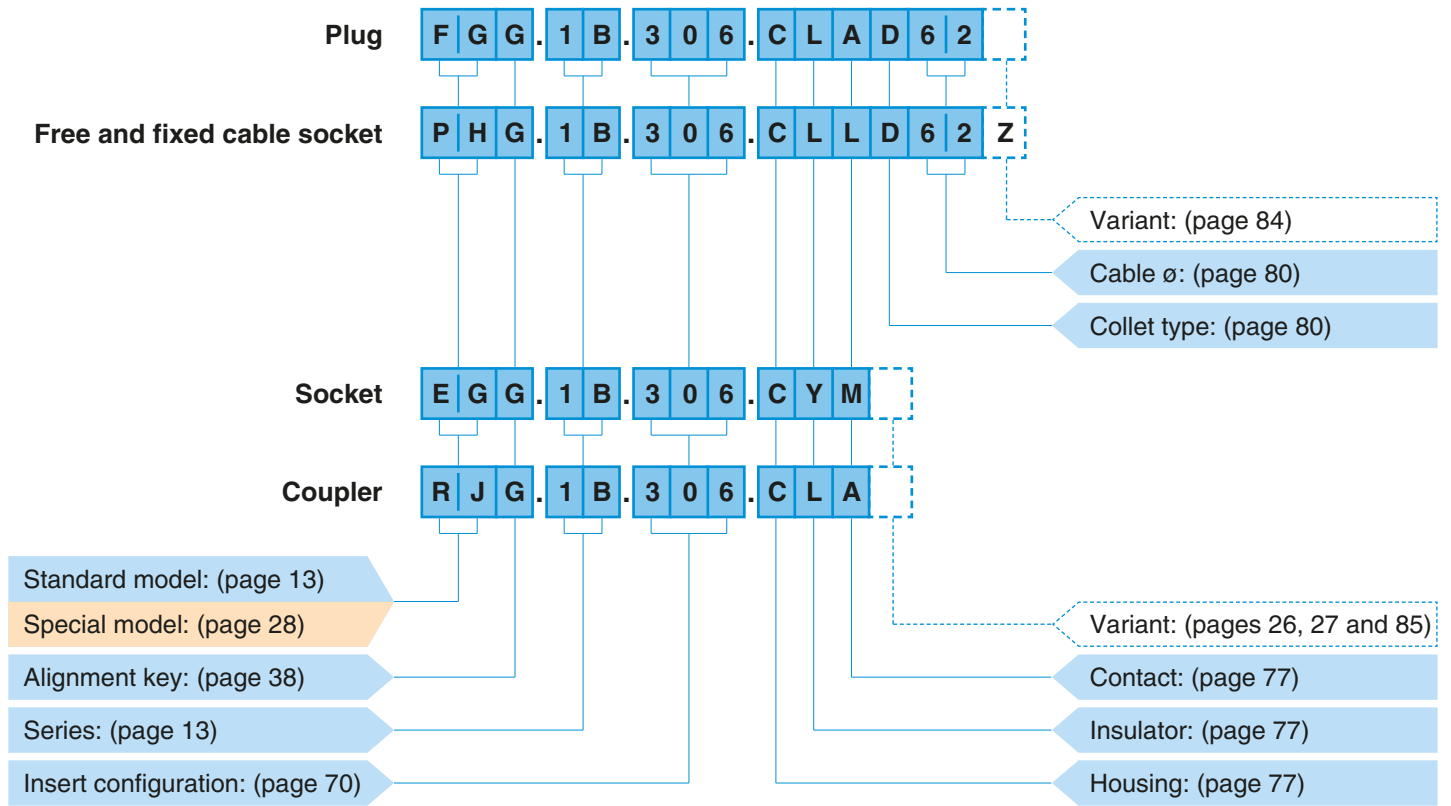

FGG.1B.306.CLAD62 = straight plug with key (G) and cable collet, 1B series, multipole type with 6 contacts, outer shell in chrome-plated brass, PEEK insulator, male solder contacts, D type collet for 6.0 mm diameter cable.

PHG.1B.306.CLLD62Z = free cable socket with key (G) and cable collet, 1B series, multipole type with 6 contacts, outer shell in chrome-plated brass, PEEK insulator, female solder contacts, D type collet for 6.0 mm diameter cable and nut for fitting a bend relief.

EGG.1B.306.CYM = socket, nut fixing, with key (G), 1B series, multipole type with 6 contacts, outer shell in chrome-plated brass, PEEK extended insulator, female crimp contacts.

RJG.1B.306.CLA = straight fixed coupler with keys (J) at the flange end and key (G) at the other end, 1B series, multipole type with 6 contacts, outer shell in chrome-plated brass, PEEK insulator, male-female contacts.



Standard models

Technical characteristics

Mechanical and environmental

Characteristics	Value	Standard
Endurance ¹⁾	> 5000 cycles	IEC 60512-5 test 9a
Humidity	up to 95% at 60°C	
Temperature range ³⁾	- 55°C, + 250°C	
Resistance to vibrations	10-2000 Hz, 15g	IEC 60068-2-6 test Fc
Shock resistance	100 g, 6 ms	IEC 60068-2-27 test Ea
Salt spray corrosion test ²⁾	> 1000h	IEC 60068-2-11 test Ka
Protection index (mated)	IP50	IEC 60529
Climatical category	55/175/21	IEC 60068-1

Electrical

Characteristics	Value	Standard	
Shielding efficiency	at 10 MHz	> 75 dB	IEC 60169-1-3 test 9a
	at 1 GHz	> 40 dB	IEC 60169-1-3 test 9a

Note:

the various tests have been carried out with FGG and EGG connector pairs, with chrome-plated brass shell and PEEK insulator.

Detailed electrical characteristics, as well as materials and treatment are presented in the chapter Technical characteristics on page 130.

¹⁾ see page 133, contact resistance after mating cycles. See page 131, mechanical endurance latching force.

²⁾ for chrome plated product («C» material code).

³⁾ maximum temperature valid for short periods of use.

FG● Straight plug, key (G or A to K), cable collet

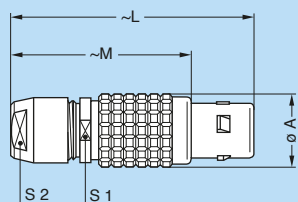

Cable collet and nut for fitting a bend relief ²⁾

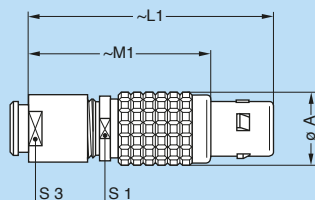

Reference		Dimensions (mm)							
Model	Series	A	L	L1	M	M1	S1	S2	S3
FG●	00 ¹⁾	6.4	28.5	28.7	20.5	20.7	5.5	5	6
FG●	0B	9.5	36.0	35.0	26.0	25.0	8.0	7	7
FG●	1B	12.0	43.0	42.0	32.0	31.0	10.0	9	9
FG●	XB	13.0	44.0	47.5	33.5	37.0	11.0	10	10
FG●	2B	15.0	50.0	49.0	38.0	37.0	13.0	12	12
FG●	3B	18.0	58.0	56.5	43.0	41.5	15.0	14	15
FG●	4B	25.0	75.0	71.0	57.0	53.0	21.0	20	20
FG●	5B	35.0	103.0	110.3	78.0	85.3	31.0	30	28

M1 Cable assembly (page 124)

Note: ¹⁾ the surface design of the 00 series is different.

● Standard ● Special

Note: ²⁾ to order, add a «Z» at the end of the reference. The bend relief must be ordered separately (see page 105).

FF● Straight plug, non-latching, key (G or A or J), cable collet

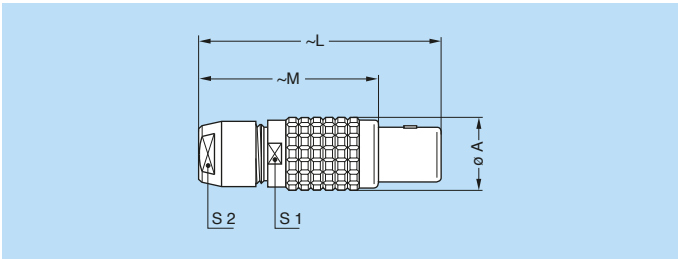

Reference		Dimensions (mm)				
Model	Series	A	L	M	S1	S2
FF●	0B	9.5	36	26	8	7
FF●	1B	12.0	43	32	10	9
FF●	2B	15.0	50	38	13	12
FF●	3B	18.0	58	43	15	14
FF●	4B	25.0	75	57	21	20

M1 Cable assembly (page 124)

● Standard ● Special

FN● Straight plug, key (G or A or J), cable collet and lanyard release

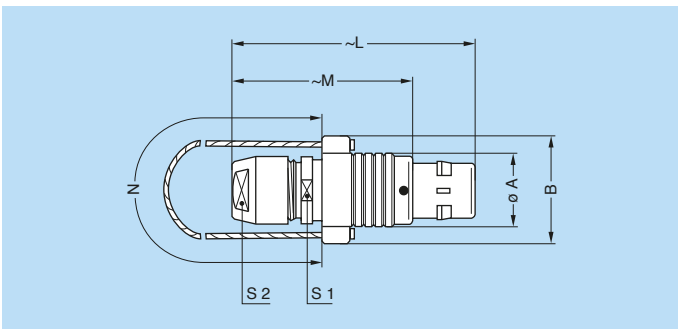
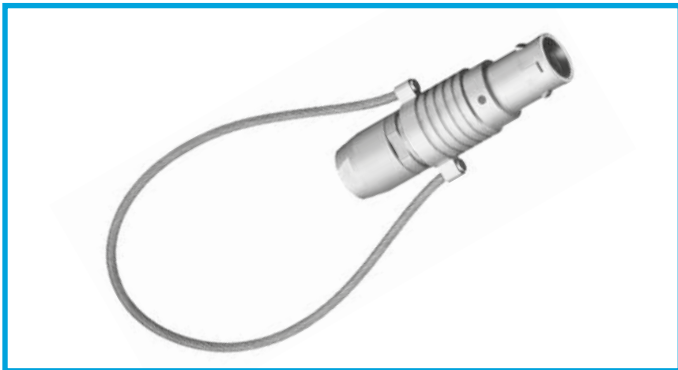

Reference		Dimensions (mm)						
Model	Series	A	B	L	M	N	S1	S2
FN●	0B	9.5	15.5	36.0	26.0	140	8	7
FN●	1B	12.0	18.0	43.0	32.0	140	10	9
FN●	2B	15.0	21.0	49.0	37.0	160	13	12
FN●	3B	18.0	25.0	58.0	43.0	190	15	14
FN●	4B	25.0	32.0	75.0	57.0	230	21	20
FN●	5B	35.0	42.0	103.0	78.0	300	31	30

M1 Cable assembly (page 124)

Note: cable material: stainless steel with Polyamide sheath.

● Standard ● Special

FW● Fixed plug, nut fixing, key (G or A to K)

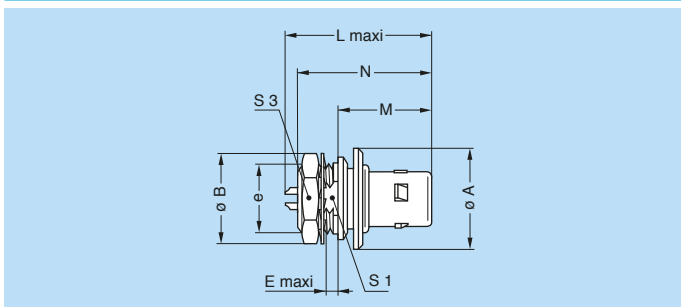

Reference		Dimensions (mm)								
Model	Series	A	B	e	E	L	M	N ¹⁾	S1	S3
FW●	0B	14.0	12.4	M9x0.6	1.8	25.6	14.5	19.5	8.2	11
FW●	1B	18.0	15.8	M12x1.0	2.9	28.5	17.0	24.8	10.5	14
FW●	2B	19.5	19.2	M15x1.0	4.1	33.6	18.0	27.3	13.5	17
FW●	3B	25.0	25.0	M18x1.0	4.2	38.2	23.0	31.5	16.5	22

P5 Panel cut-out (page 117)

Note: ¹⁾ maximum length with crimp contacts

FA● Fixed plug, non-latching, nut fixing, key (G or A to K)

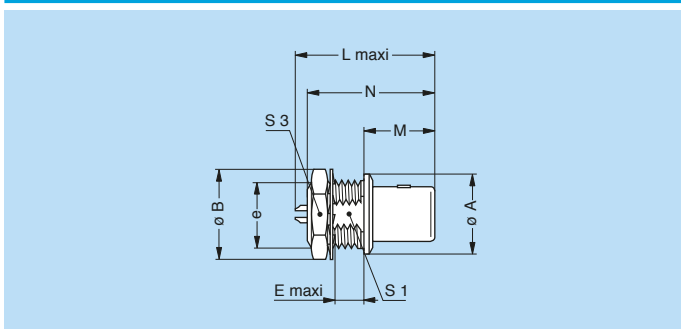

Reference		Dimensions (mm)								
Model	Series	A	B ¹⁾	e	E	L	M	N ²⁾	S1	S3
FA●	00	8	10.2	M7x0.5	2.9	18.1	9.0	15.0	6.3	9
FA●	0B	10	12.4	M9x0.6	4.2	20.8	11.5	18.9	8.2	11
FA●	1B	14	15.8	M12x1.0	5.4	25.2	12.5	21.6	10.5	14
FA●	2B	18	19.2	M15x1.0	6.0	28.7	13.8	23.9	13.5	17
FA●	3B	22	25.0	M18x1.0	5.8	32.1	17.0	30.2	16.5	22
FA●	4B	29	34.0	M25x1.0	6.8	37.1	20.5	34.7	23.5	30
FA●	5B	40	40.0	M35x1.0	6.8	47.1	28.0	42.8	33.5	–

P1 Panel cut-out (page 117)

Note:
¹⁾ the 5B series is delivered without locking washer or tapered washer and with a round nut.
²⁾ maximum length with crimp contacts.

● Standard ● Special

FP● Elbow (90°) plug, key (G or A to K), cable collet

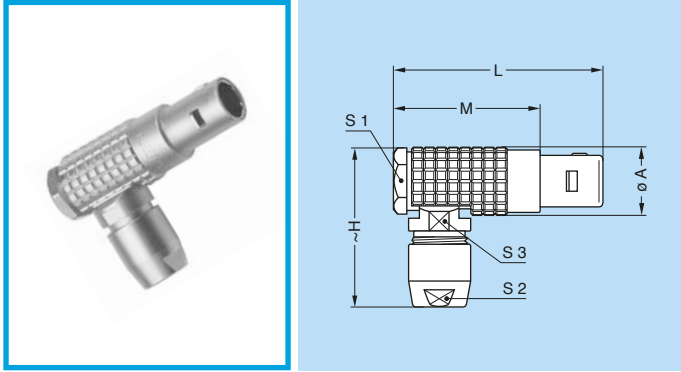

Reference		Dimensions (mm)								
Model	Series	A	H	H1	L	M	S1	S2	S3	S4
FP●	00	7.5	18	17.5	24.5	16.5	6.5	5	5.5	6
FP●	0B	9.5	23	22.0	30.0	20.0	8.0	7	8.0	7
FP●	1B	12.0	29	27.7	36.0	25.0	11.0	9	10.0	9
FP●	2B	15.0	35	34.0	41.5	29.5	13.5	12	13.0	12

M3 Cable assembly (page 124)

Cable collet and nut for fitting a bend relief ¹⁾

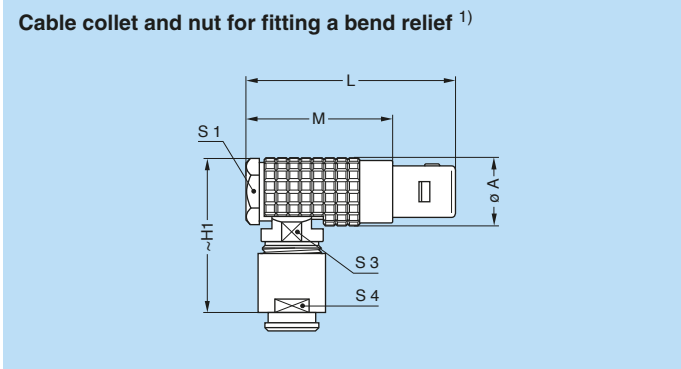

Note: ¹⁾ to order, add a «Z» at the end of the reference. The bend relief must be ordered separately (see page 105).

FS● Anglissimo right angle plug, key (G or A to K), cable collet

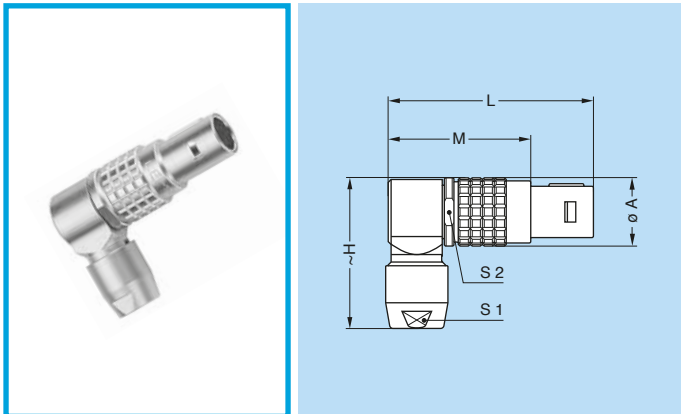

Reference		Dimensions (mm)					
Model	Series	A	H	L	M	S1	S2
FS●	00	8.0	18.1	24.8	16.8	5	7
FS●	0B	10.0	22.4	30.3	20.3	7	9
FS●	1B	12.0	26.4	36.5	25.5	9	11
FS●	2B	16.5	34.5	44.0	32.0	12	15
FS●	3B	20.0	39.2	52.4	37.4	14	19

M5 Cable assembly (page 125)

EG Socket, nut fixing, key (G or A to K)

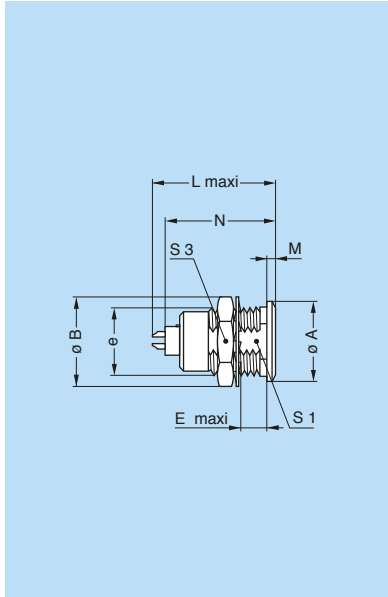

Reference		Dimensions (mm)								
Model	Series	A	B ¹⁾	e	E	L	M	N ²⁾	S1	S3
EG	00	8	10.2	M7x0.5	6.0	15.5	1.0	13.7	6.3	9
EG	0B	10	12.4	M9x0.6	7.0	20.7	1.2	19.1	8.2	11
EG	1B	14	15.8	M12x1.0	7.5	23.0	1.5	21.1	10.5	14
EG	XB	16	19.0	M14x1.0	7.0	23.5	1.5	20.0	12.5	17
EG	2B	18	19.2	M15x1.0	8.5	26.7	1.8	24.6	13.5	17
EG	3B	22	25.0	M18x1.0	11.5	30.7	2.0	28.1	16.5	22
EG	4B	28	34.0	M25x1.0	12.0	35.7	2.5	34.1	23.5	30
EG	5B	40	40.0	M35x1.0	11.0	43.5	3.0	39.6	33.5	-

P1 Panel cut-out (page 117)

Note:

- ¹⁾ the 5B series is delivered with a tapered washer and a round nut.
- ²⁾ maximum length with crimp contacts.

● Standard ● Special

EN Socket with earthing tag, nut fixing, key (G or A to K)

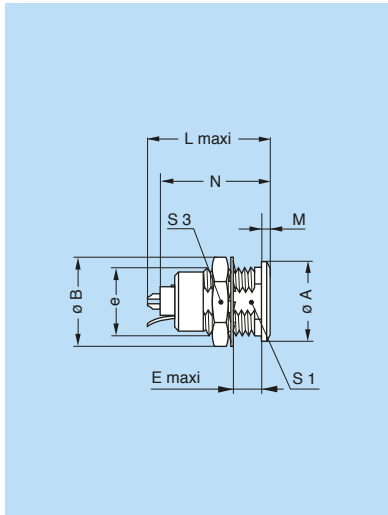

Reference		Dimensions (mm)								
Model	Series	A	B	e	E	L	M	N ¹⁾	S1	S3
EN	00	8	10.2	M7x0.5	6.0	15.5	1.0	13.7	6.3	9
EN	0B	10	12.4	M9x0.6	7.0	20.7	1.2	19.1	8.2	11
EN	1B ²⁾	14	15.8	M12x1.0	7.5	23.0	1.5	21.1	10.5	14
EN	2B	18	19.2	M15x1.0	8.5	26.7	1.8	24.6	13.5	17
EN	3B	22	25.0	M18x1.0	11.5	30.7	2.0	28.1	16.5	22
EN	4B	28	34.0	M25x1.0	12.0	35.7	2.5	34.1	23.5	30

P1 Panel cut-out (page 117)

Note:

- ¹⁾ maximum length with crimp contacts.
- ²⁾ for the 1B series the earthing tag is on the same side of the key.

● Standard ● Special

EH Socket, nut fixing, key (G or A to K), and protruding shell

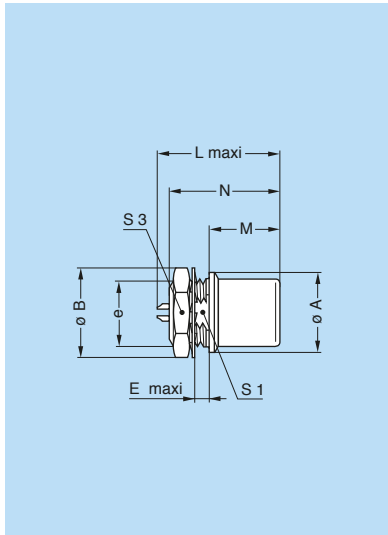

Reference		Dimensions (mm)								
Model	Series	A	B ¹⁾	e	E	L	M	N ²⁾	S1	S3
EH	00	8	10.2	M7x0.5	2.0	15.5	8.5	13.7	6.3	9
EH	0B	10	12.4	M9x0.6	2.0	19.5	12.5	19.1	8.2	11
EH	1B	14	15.8	M12x1.0	4.0	21.7	12.0	21.1	10.5	14
EH	2B	18	19.2	M15x1.0	5.1	22.7	12.5	24.6	13.5	17
EH	3B	22	25.0	M18x1.0	7.1	30.7	13.5	30.3	16.5	22
EH	5B	40	40.0	M35x1.0	2.5	43.5	28.0	38.5	33.5	-

P1 Panel cut-out (page 117)

Note:

- ¹⁾ the 5B series is delivered without locking washer or tapered washer and with a round nut.
- ²⁾ maximum length with crimp contacts.

● Standard ● Special

EE● Socket, nut fixing, key (G or A to K) (back panel mounting)

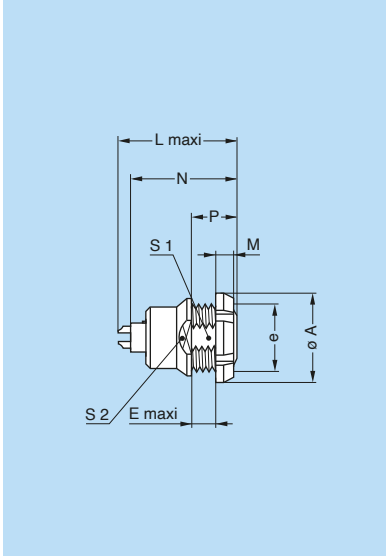

Reference		Dimensions (mm)								
Model	Series	A ¹⁾	e	E	L	M	N ²⁾	P	S1	S2
EE●	00	10	M7x0.5	2.3	15.5	2.5	13.7	6.0	6.3	7.5
EE●	0B	12	M9x0.6	2.4	20.7	2.5	19.1	6.3	8.2	9.0
EE●	1B	16	M12x1.0	6.5	23.0	3.5	21.1	11.0	10.5	13.0
EE●	2B	20	M15x1.0	4.3	26.7	3.5	24.6	9.0	13.5	15.0
EE●	3B	24	M18x1.0	6.1	30.7	4.5	28.1	12.0	16.5	20.0
EE●	4B	30	M25x1.0	10.6	35.7	4.5	34.1	16.5	23.5	26.0
EE●	5B	41	M35x1.0	13.5	43.5	5.0	39.6	19.5	33.5	38.0

P1 Panel cut-out (page 117)

Note:

- ¹⁾ the 3B, 4B and 5B series are delivered with a conical nut.
- ²⁾ maximum length with crimp contacts.

● Standard ● Special

EA● Socket with earthing tag, nut fixing, key (G or A to K) (back panel mounting)

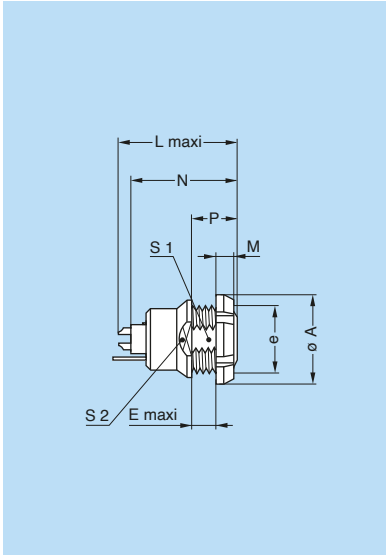

Reference		Dimensions (mm)								
Model	Series	A ¹⁾	e	E	L	M	N ²⁾	P	S1	S2
EA●	00	10	M7x0.5	2.3	15.5	2.5	13.7	6.0	6.3	7.5
EA●	0B	12	M9x0.6	2.4	20.7	2.5	19.1	6.3	8.2	9.0
EA●	1B	16	M12x1.0	6.5	23.0	3.5	21.1	11.0	10.5	13.0
EA●	2B	20	M15x1.0	4.3	26.7	3.5	24.6	9.0	13.5	15.0
EA●	3B	24	M18x1.0	6.1	30.7	4.5	28.1	12.0	16.5	20.0
EA●	4B	30	M25x1.0	10.6	35.7	4.5	34.1	16.5	23.5	26.0
EA●	5B	41	M35x1.0	13.5	43.5	5.0	39.6	19.5	33.5	38.0

P1 Panel cut-out (page 117)

Note:

- ¹⁾ the 3B, 4B and 5B series are delivered with a conical nut.
- ²⁾ maximum length with crimp contacts.

● Standard ● Special

EC● Socket with two nuts, key (G or A to K)

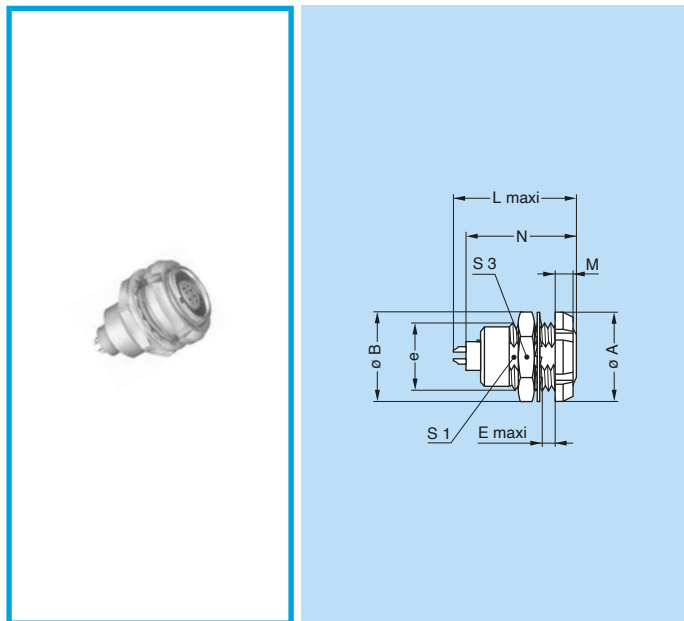

Reference		Dimensions (mm)								
Model	Series	A ¹⁾	B	e	E	L	M	N ²⁾	S1	S3
EC●	00	10	10.2	M7x0.5	4.3	13.7	2.5	13.7	6.3	9
EC●	0B	12	12.4	M9x0.6	5.5	20.7	2.5	19.1	8.2	11
EC●	1B	16	15.8	M12x1.0	6.0	23.0	3.5	21.1	10.5	14
EC●	XB	18	19.0	M14x1.0	6.0	23.5	3.5	20.0	12.5	17
EC●	2B	20	19.2	M15x1.0	6.5	26.7	3.5	24.6	13.5	17
EC●	3B	24	25.0	M18x1.0	9.0	30.7	4.5	28.1	16.5	22
EC●	4B	30	34.0	M25x1.0	10.0	35.7	4.5	32.6	23.5	30
EC●	5B	41	40.0	M35x1.0	9.0	43.5	5.0	39.6	33.5	–

P1 Panel cut-out (page 117)

Note:

- 1) the 3B, 4B series are delivered with a conical nut. The 5B series is delivered with a round nut and a conical nut.
- 2) maximum length with crimp contacts.

● Standard ● Special

EZ● Socket for printed circuit, key (G or A or B)

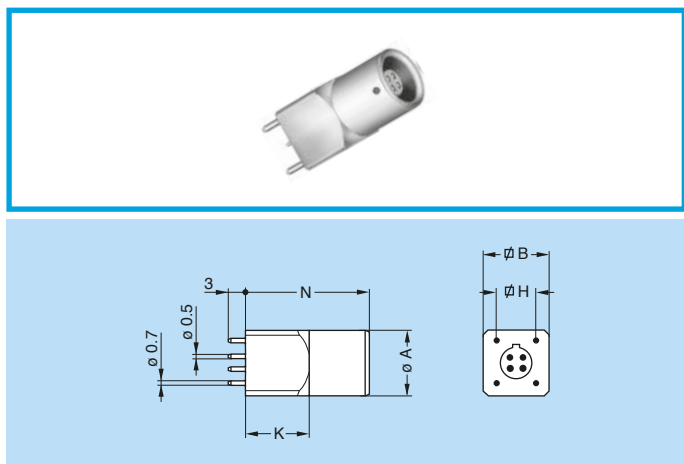

Reference		Dimensions (mm)				
Model	Series	A	B	H	K	N
EZ●	00	6.8	7	5.08	7	14

P7 + **P8** PCB drilling pattern (pages 119 and 120)

EZ● Socket for printed circuit, key (G or A to F)

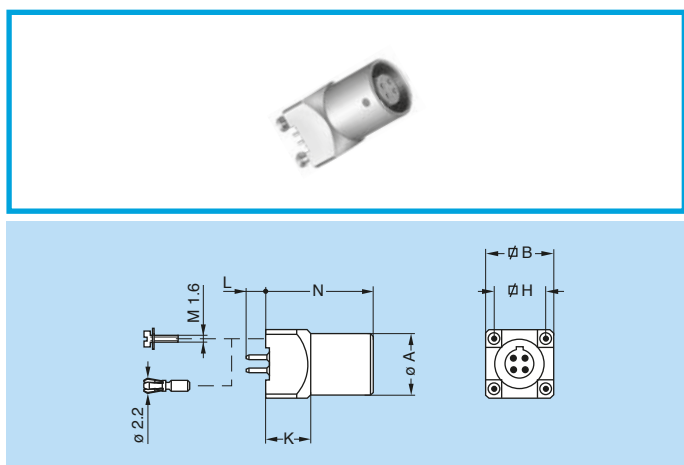

Reference		Dimensions (mm)				
Model	Series	A	B	H	K	N
EZ●	0B	9	10	7.62	8	15.0
EZ●	1B	11	12	7.62	8	19.0
EZ●	2B	14	15	10.16	9	22.5

P7 + **P8** PCB drilling pattern (pages 119 and 120)

Note: Length «L» depends on the number of contacts, see page 120. Add letter «B» at the end of the reference to order with integrated harpoon pins (1.6 mm PCB thickness) (only for 0B and 1B series).

PF● Fixed cable socket, with two nuts, key (G or A to K), cable collet (back panel mounting)

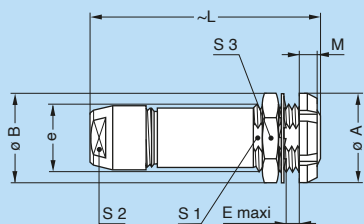

Reference		Dimensions (mm)								
Model	Series	A ¹⁾	B	e	E	L	M	S1	S2	S3
PF●	00	10	10.2	M7x0.5	5.3	26.0	2.5	6.3	5	9
PF●	0B	12	12.4	M9x0.6	5.0	35.5	2.5	8.2	7	11
PF●	1B	16	15.8	M12x1.0	5.0	40.5	3.5	10.5	9	14
PF●	2B	20	19.2	M15x1.0	6.5	47.0	3.5	13.5	12	17
PF●	3B	24	25.0	M18x1.0	9.0	56.0	4.5	16.5	14	22
PF●	4B	30	34.0	M25x1.0	11.0	73.0	4.5	23.5	20	30
PF●	5B	41	40.0	M35x1.0	10.0	99.0	5.0	33.5	30	-

P1 Panel cut-out (page 117)

M1 Cable assembly (page 124)

Note:

¹⁾ the 3B, 4B series are delivered with a conical nut.
The 5B series is delivered with a round nut and a conical nut.

● Standard ● Special

R●● Fixed coupler, nut fixing, key (G or A or J) at the flange end and key (J or K) at the other end

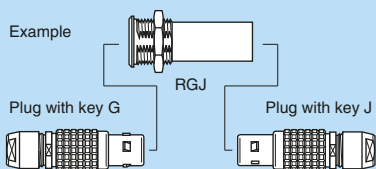
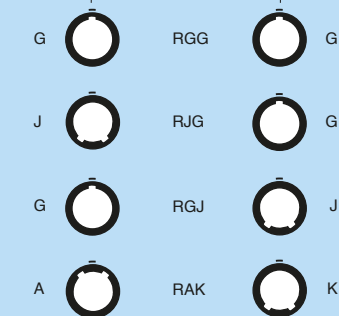
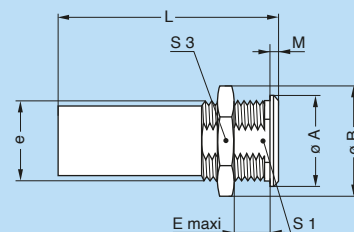
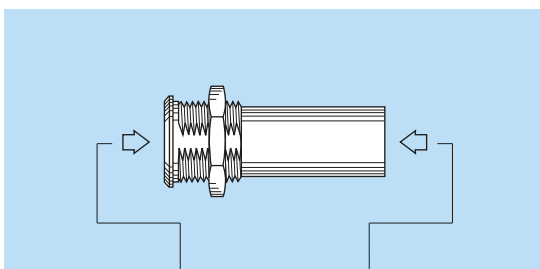

Alignment key see page 38.

Reference		Contacts	Dimensions (mm)								
Model	Series	Type	A	B	e	E	L	M	S1	S3	
RGG ¹⁾	0B	female – female	12	13.8	M10x0.75	8.0	34	2.0	9.0	12	
RGG ²⁾	0B	female – female	12	13.8	M10x0.75	8.0	43	2.0	9.0	12	
RJG	0B	male – female	12	13.8	M10x0.75	8.0	34	2.0	9.0	12	
RGJ	0B	female – male	12	13.8	M10x0.75	8.0	34	2.0	9.0	12	
RAK	0B	female – male	12	13.8	M10x0.75	8.0	34	2.0	9.0	12	
RGG ³⁾	1B	female – female	16	19.2	M14x1.00	8.5	47	2.5	12.5	17	
RJG	1B	male – female	16	19.2	M14x1.00	8.5	39	2.5	12.5	17	
RGJ	1B	female – male	16	19.2	M14x1.00	8.5	39	2.5	12.5	17	
RJG	2B	male – female	20	21.5	M16x1.00	12.0	44	4.0	15.0	19	
RGJ	2B	female – male	20	21.5	M16x1.00	12.0	44	4.0	15.0	19	
RGJ	3B	female – male	25	27.0	M20x1.00	32.0	53	4.0	18.5	24	
RGJ	4B	female – male	34	34.0	M25x1.00	50.0	65	4.0	23.5	30	

P4 Panel cut-out (page 117)

Note: for this fixed coupler, the first contact type mentioned is always the one at the flange end. On request, these couplers can be produced in other series, with other keys.

¹⁾ only available with two contacts.

²⁾ RGG.0B only available from 3 till 5 contacts.

³⁾ RGG.1B only available till 7 contacts.

● Standard ● Special

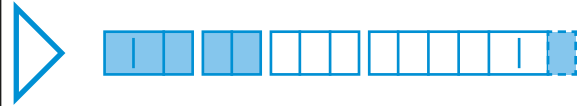

Watertight or vacuumtight models

These plug, socket and coupler models allow the device on which they are fitted to reach a protection index of IP68 as per IEC 60529. They are fully compatible with plugs of the same series and are widely used for portable radios, military, laboratory equipment, aviation, etc.

Watertight models are identified by a letter «P» at the end of the reference.

Most of these models are also available in a vacuumtight version. Such models are identified by the letters «PV» at the end of the part number (certificate on request).

Epoxy resin is used to seal these models.

Technical characteristics

Mechanical and environmental

Characteristics	Value	Standard
Endurance ¹⁾	> 5000 cycles	IEC 60512-5 test 9a
Humidity	up to 95% at 60°C	
Temperature range	00 to 1B	- 20°C, + 100°C
	2B to 5B	- 20°C, + 80°C
Salt spray corrosion test ⁴⁾	> 1000h	IEC 60068-2-11 test Ka
Climatical category	20/80/21	IEC 60068-1
Leakage rate (He) ²⁾	< 10 ⁻⁷ mbar.l.s ⁻¹	IEC 60512-2-17 test Qk

Characteristics	Value	Standard	
Maximum operating pressure ³⁾	00	60 bar	IEC 60512-7 test 14d
	0B	60 bar	IEC 60512-7 test 14d
	1B	60 bar	IEC 60512-7 test 14d
	2B	40 bar	IEC 60512-7 test 14d
	3B	30 bar	IEC 60512-7 test 14d
	4B	15 bar	IEC 60512-7 test 14d
	5B	5 bar	IEC 60512-7 test 14d

Note:

¹⁾ see page 133, contact resistance after mating cycles. See page 131, mechanical endurance latching force.

²⁾ only for vacuumtight models. Residual traces of grease used during (He) leak testing are on the o-ring. Please contact us for further details.

³⁾ this value corresponds to the maximum allowed pressure difference for the assembled socket.

⁴⁾ for chrome plated product («C» material code).

HG● Socket, nut fixing, key (G or A to K), watertight or vacuumtight

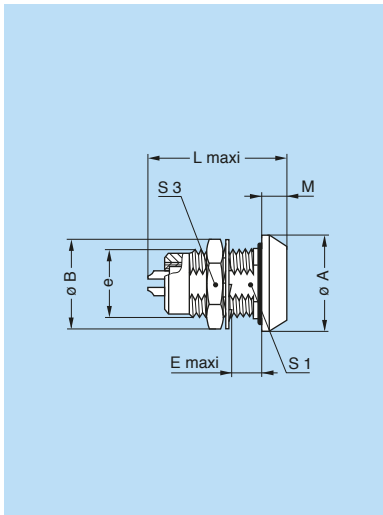

Reference		Dimensions (mm)							
Model	Series	A ¹⁾	B	e	E	L	M	S1	S3
HG●	00	11	10.2	M7x0.5	8.0	18.0	1.5	–	9
HG●	0B	13	12.4	M9x0.6	7.0	21.5	3.0	8.2	11
HG●	1B	18	15.8	M12x1.0	7.0	26.6	4.5	10.5	14
HG●	2B	20	19.2	M15x1.0	8.0	31.6	4.0	13.5	17
HG●	3B	25	25.0	M18x1.0	11.5	36.1	4.0	16.5	22
HG●	4B	34	34.0	M25x1.0	11.0	43.1	4.0	23.5	30
HG●	5B	45	40.0	M35x1.0	11.0	53.6	5.0	33.5	–

P5 Panel cut-out (page 117)

Note: ¹⁾ the 5B series is delivered with a tapered washer and a round nut.

● Standard ● Special

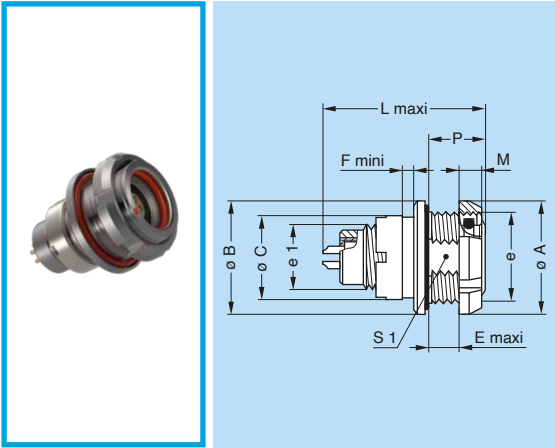
HC● Socket, nut fixing, key (G or A to K), watertight or vacuumtight (watertight when mated)
 (back panel mounting)

Reference		Dimensions (mm)										
Model	Series	A	B	C	e	e1	E	F	L	M	P	S1
HC●	0B	18	18	12.0	M14x1.0	M9x0.6	3.9	1.0	24.5	3.5	7.5	12.5
HC●	1B	20	20	14.5	M16x1.0	M12x1.0	6.2	2.0	30.3	3.5	10.0	14.5
HC●	2B	24	24	17.5	M19x1.0	M14x1.0	6.7	2.0	35.6	3.5	11.3	17.0

P3 Panel cut-out (page 117)

Note: this model ensures watertightness (IP66) in the mating area when mated with FGG or similar plug.

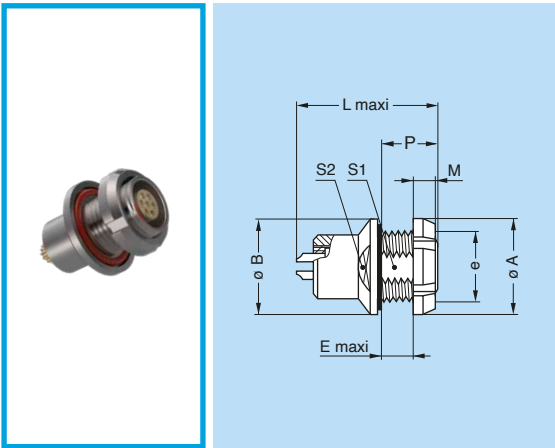
HE● Socket, nut fixing, key (G or A to K), watertight or vacuumtight (back panel mounting)

Reference		Dimensions (mm)									
Model	Series	A	B	e	E	L	M	P	S1	S2	
HE●	00	10	11	M7x0.5	2.5	18.2	2.5	6.0	6.3	–	
HE●	0B	12	13	M9x0.6	5.5	21.5	2.5	9.0	8.2	–	
HE●	1B	16	18	M12x1.0	6.5	26.6	3.5	11.0	10.5	–	
HE●	2B	20	20	M15x1.0	5.0	31.6	3.5	9.6	13.5	15	

P5 Panel cut-out (page 117)

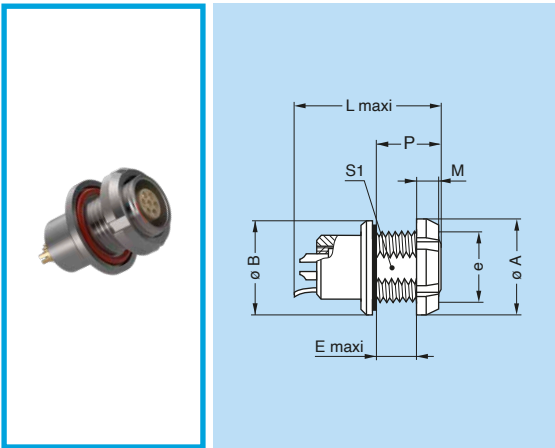
HM● Socket with earthing tag, nut fixing, key (G or A to K), watertight or vacuumtight
 (back panel mounting)

Reference		Dimensions (mm)								
Model	Series	A ¹⁾	B	e	E	L	M	P	S1	
HM●	00	10	11	M7x0.5	2.5	18.0	2.5	6.0	6.3	
HM●	0B	12	13	M9x0.6	5.5	21.5	2.5	9.0	8.2	
HM●	1B	16	18	M12x1.0	5.5	26.6	3.5	11.0	10.5	
HM●	2B ²⁾	20	20	M15x1.0	5.5	31.6	3.5	9.6	13.5	
HM●	3B	24	25	M18x1.0	7.5	36.1	4.5	14.0	16.5	

P5 Panel cut-out (page 117)

Note:

- ¹⁾ the 3B series is delivered with a conical nut.
- ²⁾ the surface design of the 2B series is different.

S●● Fixed coupler, nut fixing, key (G or A, J or K) at the flange end and key (G or A, J or K) at the other end, watertight or vacuumtight

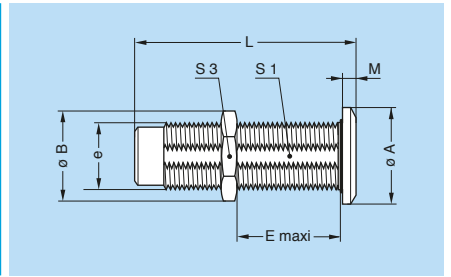
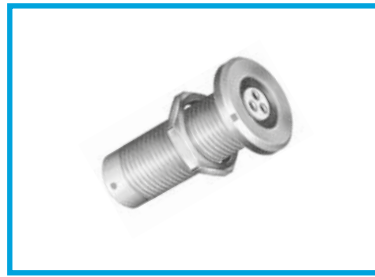
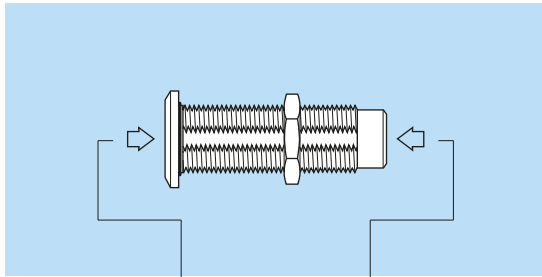

G

SGJ

J

J

SJG

G

K

SKA

A

A

SAK

K

Example

Plug with key G SGJ Plug with key J

Alignment key see page 38.

Reference		Contacts Type	Dimensions (mm)							
Model	Series		A	B ¹⁾	e	E	L	M	S1	S3
SGJ	0B	female – male	14	13.8	M10x0.75	17	34	2.0	9.0	12
SJG	0B	male – female	14	13.8	M10x0.75	17	34	2.0	9.0	12
SGJ	1B	female – male	17	15.8	M12x1.00	28	39	2.5	10.5	14
SJG	1B	male – female	17	15.8	M12x1.00	28	39	2.5	10.5	14
SGJ	2B	female – male	20	21.5	M16x1.00	25	44	4.0	15.0	19
SJG	2B	male – female	20	21.5	M16x1.00	25	44	4.0	15.0	19
SGJ	3B	female – male	25	27.0	M20x1.00	30	53	4.0	18.5	24
SJG	3B	male – female	25	27.0	M20x1.00	30	53	4.0	18.5	24
SAK	3B	female – male	25	27.0	M20x1.00	30	53	4.0	18.5	24
SAK	4B	female – male	34	34.0	M25x1.00	50	65	4.0	23.5	30
SGJ	4B	female – male	34	34.0	M25x1.00	50	65	4.0	23.5	30
SJG	4B	male – female	34	34.0	M25x1.00	50	65	4.0	23.5	30
SGJ	5B	female – male	45	40.0	M35x1.00	58	80	5.0	33.5	–
SJG	5B	male – female	45	40.0	M35x1.00	58	80	5.0	33.5	–
SKA	5B	male – female	45	40.0	M35x1.00	58	80	5.0	33.5	–
SAK	5B	female – male	45	40.0	M35x1.00	58	80	5.0	33.5	–

P4 Panel cut-out (page 117)

P5 Panel cut-out 1B series (page 117)

Note: ¹⁾ the 5B series is delivered with a round nut.

Note: for this fixed coupler, the first contact type mentioned is always the one at the flange end. On request these couplers can be produced in other series, with other keys.

● Standard ● Special



Elbow socket models

Technical characteristics

Types

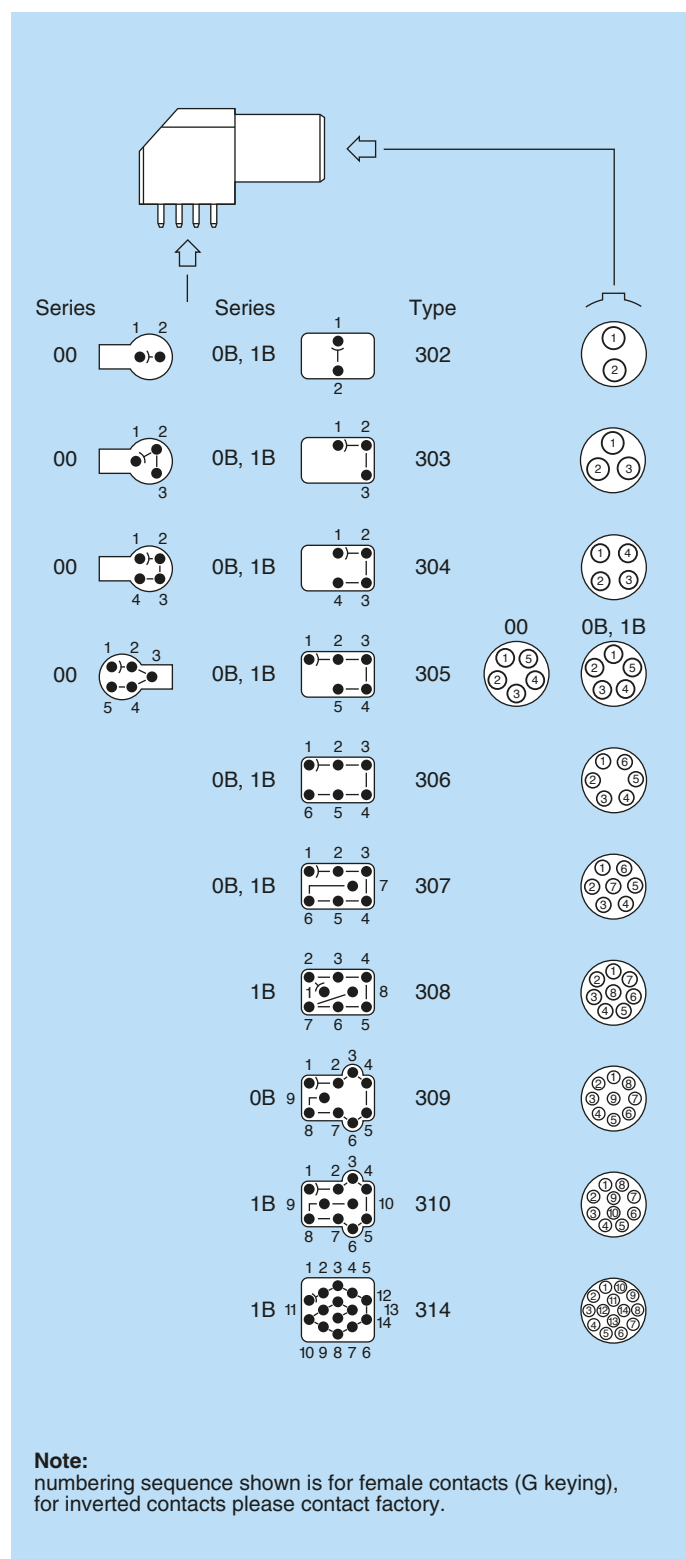

Materials and treatment

Component	Material	Surface Treat. (µm)		
		Cu	Ni	Au
Housing	PPS	-		
	Brass	0.5	3	-
Metallic parts	Brass	0.5	3	-
Earthing crown	Bronze	0.5	3	-
Insulator	PEEK	-		
Female contact	Bronze	0.5	3	1.5

Note:

The surface treatment standards are as follows:
- Nickel: SAE AMS QQ N 290. - Gold: ISO 27874

Electrical

Model	Series	Types	Test voltage (kV DC) ¹⁾ Contact-contact	Test voltage (kV DC) ¹⁾ Contact-shell	Rated current (A) ¹⁾
EP•-XB•	00	302-303-304-305	1.40	1.40	2.0
EP•-EX•	0B	302	2.03	1.68	4.5
EP•-EX•	0B	303	2.38	2.24	4.5
EP•-EX•	0B	304	1.82	1.54	4.5
EP•-EX•	0B	305	1.75	1.68	4.5
EP•-EX•	0B	306	1.75	1.68	2.5
EP•-EX•	0B	307	1.40	1.40	2.0
EP•-EX•	0B	309	0.84	0.70	1.5
EP•-EX•	1B	302	2.38	2.03	4.5
EP•-EX•	1B	303	2.24	2.59	4.5
EP•-EX•	1B	304	2.38	2.52	4.5
EP•-EX•	1B	305	1.82	2.17	4.5
EP•-EX•	1B	306	1.89	2.03	4.5
EP•-EX•	1B	307	2.03	2.03	2.0
EP•-EX•	1B	308	1.82	1.82	2.0
EP•-EX•	1B	310	1.40	1.40	1.5
EP•	1B	314	1.40	1.82	1.0

Note:

¹⁾ see calculation method, caution and suggested standard on page 134.

P10 PCB drilling pattern (page 122)

P11 PCB drilling pattern (page 122 and 123)

EX● Elbow (90°) socket for printed circuit with two nuts, key (G or A to F) (solder, screw or harpoon fixing) (back panel mounting)

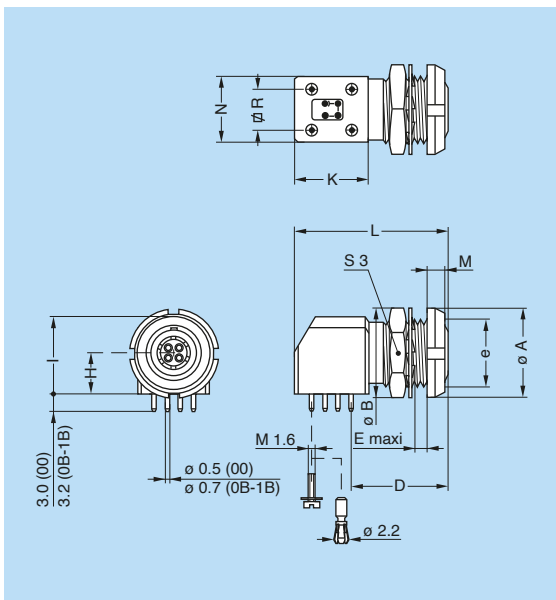

Note: In the 0B and 1B series, it is possible to replace the 4 ground pins by 4 screws (M1.6) add a «S» to the end of the part number. (e.g.: EXG.0B.307.HLNS). A second alternative is to add a «B» at the end of the part number (EXG.0B.307.HLNB), the connector is delivered with integrated harpoon pins for rapidly assembly (1.6 mm PCB thickness).

Part number	Dimensions (mm)												
	A	B	D	e	E	H	I	K	L	M	N	R	S3
EX●.0B.302.HLN													
EX●.0B.303.HLN													
EX●.0B.304.HLN													
EX●.0B.305.HLN	12	12.4	14.6	M9x0.6	4.5	6.7	12.6	13.3	25	2.5	11.7	7.62	11
EX●.0B.306.HLN													
EX●.0B.307.HLN													
EX●.0B.309.HLN													
EX●.1B.302.HLN													
EX●.1B.303.HLN													
EX●.1B.304.HLN													
EX●.1B.305.HLN	14	15.0	16.6	M11x0.5	4.5	7.5	14.0	13.3	27	3.5	12.6	7.62	13
EX●.1B.306.HLN													
EX●.1B.307.HLN													
EX●.1B.308.HLN													
EX●.1B.310.HLN													

- P2** Panel cut-out 0B series (page 117)
- P6** Panel cut-out 1B series (page 117)
- P11** PCB drilling pattern 0B, 1B series (page 122 and 123)

EC● Elbow socket for printed circuit with two nuts, key (G or A to F) with elbow (90°) contact (back panel mounting)

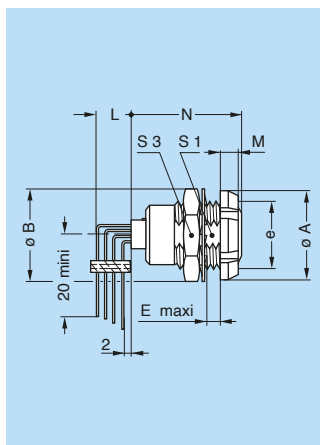

Reference		Dimensions (mm)								
Model	Series	A ¹⁾	B	e	E	M	N _{max}	S1	S3	
EC●	0B	12	12.4	M9x0.6	5.5	2.5	18.3	8.2	11	
EC●	1B	16	15.8	M12x1.0	6.0	3.5	20.3	10.5	14	
EC●	2B	20	19.2	M15x1.0	6.5	3.5	24.3	13.5	17	
EC●	3B	24	25.0	M18x1.0	9.0	4.5	27.8	16.5	22	

- P1** Panel cut-out (page 117)
- P9** PCB drilling pattern (page 121)

Note: ¹⁾ the 3B series is delivered with a conical nut.

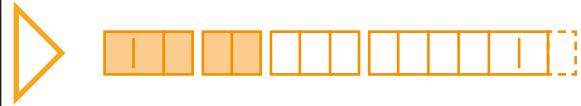

Special models

Technical characteristics

Mechanical and environmental

Characteristics	Value	Standard
Endurance ¹⁾	> 5000 cycles ²⁾	IEC 60512-5 test 9a
Humidity	up to 95% at 60°C	
Temperature range ⁴⁾	- 55°C, + 250°C	
Resistance to vibrations	10-2000 Hz, 15g	IEC 60068-2-6 test Fc
Shock resistance	100 g, 6 ms	IEC 60068-2-27 test Ea
Salt spray corrosion test ³⁾	> 1000h	IEC 60068-2-11 test Ka
Protection index (mated)	IP50	IEC 60529
Climatical category	55/175/21	IEC 60068-1

Electrical

Characteristics	Value	Standard
Shielding efficiency	at 10 MHz	> 75 dB
	at 1 GHz	> 40 dB

Note:

the various tests have been carried out with FGG and EGG connector pairs, with chrome-plated brass shell and PEEK insulator.

Detailed electrical characteristics, as well as materials and treatment are presented in the chapter Technical characteristics on page 130.

¹⁾ see page 133, contact resistance after mating cycles. See page 131, mechanical endurance latching force.

²⁾ 1000 cycles for FEG models.

³⁾ for chrome plated product (« C » material code).

⁴⁾ maximum temperature valid for short periods of use.

JGG Straight plug, short version, key (G), cable collet

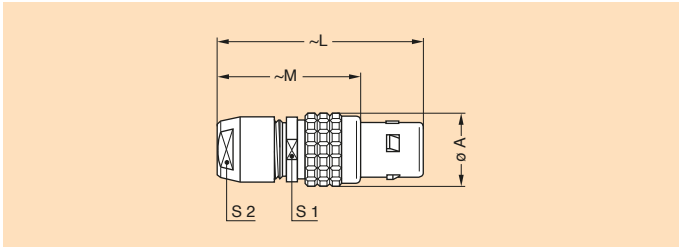

Reference		Dimensions (mm)				
Model	Series	A	L	M	S1	S2
JGG	0B	9.5	32	22	8	7

M4 Cable assembly (page 126)

FE● Straight plug, key (G or A to K), cable collet, front seal and nut for fitting a bend relief ¹⁾ (IP 54 protection index when mated)

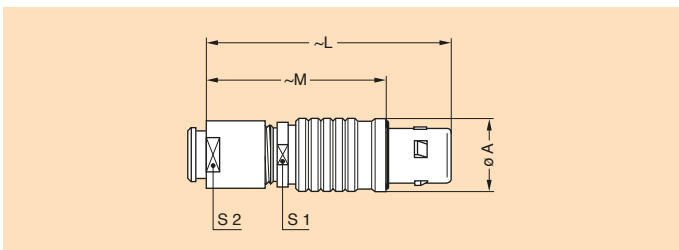

Reference		Dimensions (mm)				
Model	Series	A	L	M	S1	S2
FE●	0B	11.0	35.0	25.0	8	7
FE●	1B	13.5	42.0	33.0	10	9
FE●	2B	16.5	48.0	36.0	13	12
FE●	3B	19.4	56.5	41.5	15	15

M1 Cable assembly (page 124)

Note: ¹⁾ to order, add a « Z » at the end of the reference. The bend relief must be ordered separately (see page 105).

FD● Straight plug, long version, key (G or A to K), cable collet

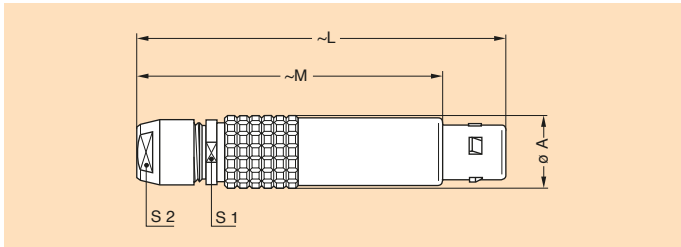

Reference		Dimensions (mm)				
Model	Series	A	L	M	S1	S2
FD●	1B	12	68	57	10	9
FD●	2B	15	79	67	13	12

M2 Cable assembly (page 126)

FH● Elbow (90°) plug, key (G or A to K), cable collet

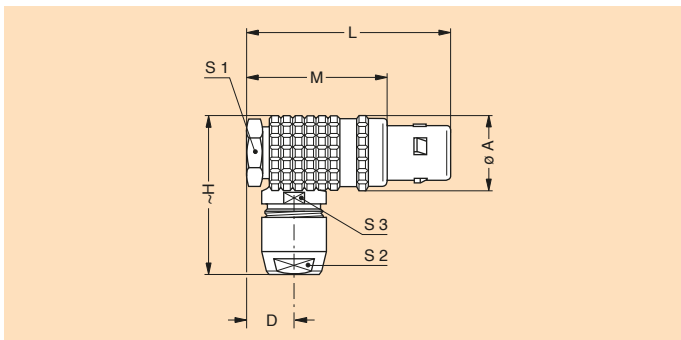

Reference		Dimensions (mm)							
Model	Series	A	D	H	L	M	S1	S2	S3
FH●	4B	26	15	52	67	49	22	20	21
FH●	5B	36	21	74	90	65	32	30	31

M3 Cable assembly (page 124)

EF● Socket, nut fixing, key (G or A to K), with two flats on the shell and O-ring (back panel mounting)

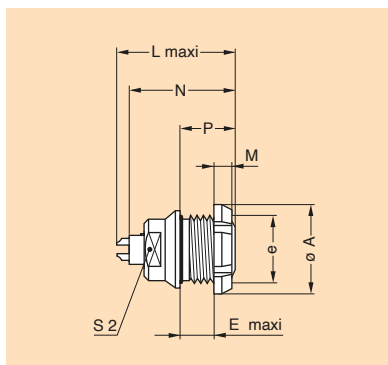

Reference		Dimensions (mm)							
Model	Series	A	e	E	L	M	N ¹⁾	P	S2
EF●	0B	12	M9x0.6	5.5	20.7	2.5	19.1	9	8

P2 Panel cut-out (page 117)

Note: ¹⁾ maximum length with crimp contacts.

PN● Free cable socket, nut fixing, key (G or A to K), cable collet with lanyard release

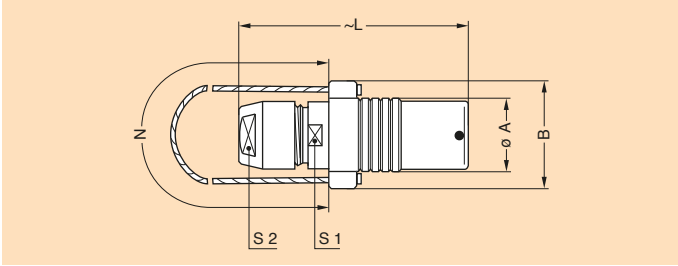
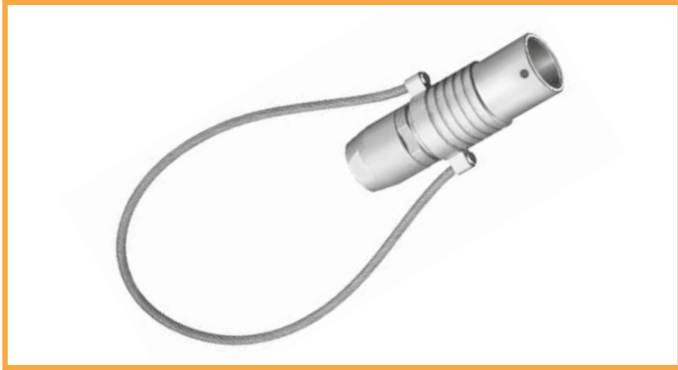

Reference		Dimensions (mm)					
Model	Series	A	B	L	N	S1	S2
PN●	1B	12.4	18.4	40.5	140	10	9
PN●	2B	16.5	22.5	47.0	160	13	12
PN●	3B	19.0	26.0	56.0	190	15	14
PN●	4B	26.0	33.0	73.0	230	21	20
PN●	5B	36.0	43.0	99.0	300	31	30

M1 Cable assembly (page 124)

Note: cable material: stainless steel with Polyamide sheath.

PK● Fixed cable socket, nut fixing, key (G or A to K), cable collet

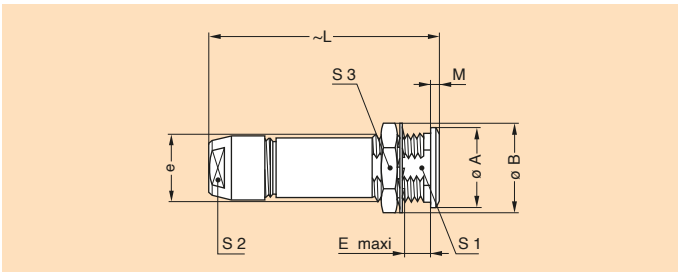

Reference		Dimensions (mm)								
Model	Series	A ¹⁾	B	e	E	L	M	S1	S2	S3
PK●	00	8	10.2	M7x0.5	6.5	26.0	1.0	6.3	5	9
PK●	0B	10	12.4	M9x0.6	7.0	35.5	1.2	8.2	7	11
PK●	1B	14	15.8	M12x1.0	7.5	40.5	1.5	10.5	9	14
PK●	2B	18	19.2	M15x1.0	8.5	47.0	1.8	13.5	12	17
PK●	3B	22	25.0	M18x1.0	11.5	56.0	2.0	16.5	14	22
PK●	4B	28	34.0	M25x1.0	12.0	73.0	2.5	23.5	20	30
PK●	5B	40	40.0	M35x1.0	11.0	99.0	3.0	33.5	30	—

P1 Panel cut-out (page 117)

M1 Cable assembly (page 124)

Note: ¹⁾ the 5B series is delivered with a tapered washer and a round nut.

PE● Fixed cable socket, nut fixing, key (G or A to K), cable collet (back panel mounting)

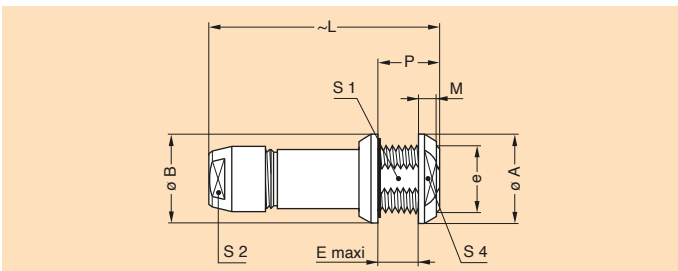

Reference		Dimensions (mm)									
Model	Series	A	B	e	E	L	M	P	S1	S2	S4
PE●	3B	24	25	M18x1.0	5.0	56	4.5	12	16.5	14	20
PE●	4B	32	34	M25x1.0	12.5	73	5.0	20	23.5	20	27

P1 Panel cut-out (page 117)

M1 Cable assembly (page 124)

Note: this model has an o-ring on the flange.



Watertight or vacuumtight models

These plug, socket and coupler models allow the device on which they are fitted to reach a protection index of IP68 as per IEC 60529. They are fully compatible with plugs of the same series and are widely used for portable radios, military, laboratory equipment, aviation, etc.

Watertight models are identified by a letter «P» at the end of the reference.

Most of these models are also available in a vacuumtight version. Such models are identified by the letters «PV» at the end of the part number (certificate on request).

Technical characteristics

Mechanical and environmental

Characteristics	Value	Standard
Endurance ¹⁾	> 5000 cycles	IEC 60512-5 test 9a
Humidity	up to 95% at 60°C	
Temperature range	0B to 1B	- 20°C, + 100°C
	2B to 3B	- 20°C, + 80°C
Salt spray corrosion test ⁴⁾	> 1000h	IEC 60068-2-11 test Ka
Climatical category	20/80/21	IEC 60068-1
Leakage rate (He) ²⁾	< 10 ⁻⁷ mbar.l.s ⁻¹	IEC 60512-2-17 test Qk

Characteristics	Value	Standard
Maximum operating pressure ³⁾	0B	60 bar
	1B	60 bar
	2B	40 bar
	3B	30 bar

Note:

¹⁾ see page 133, contact resistance after mating cycles. See page 131, mechanical endurance latching force.

²⁾ only for vacuumtight models. Residual traces of grease used during (He) leak testing are on the o-ring. Please contact us for further details.

³⁾ this value corresponds to the maximum allowed pressure difference for the assembled socket.

⁴⁾ for chrome plated product («C» material code).

YH● Fixed plug, nut fixing, non-latching, key (G or A to K)

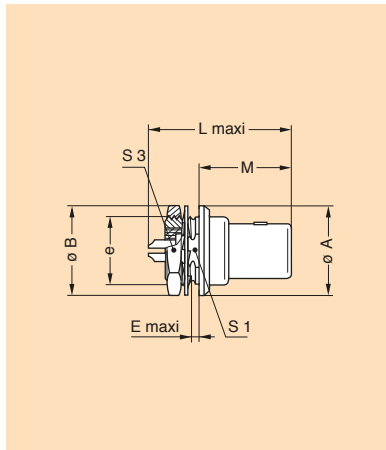

Reference		Dimensions (mm)								
Model	Series	A	B	e	E	L	M	S1	S3	
YH●	0B	13	12.4	M9x0.6	2.4	24.1	14.2	8.2	11	
YH●	1B	16	15.8	M12x1.0	3.9	28.0	16.2	10.5	14	
YH●	2B	19	19.2	M15x1.0	5.5	33.1	17.8	13.5	17	
YH●	3B	22	25.0	M18x1.0	5.1	38.2	22.2	16.5	22	

P5 Panel cut-out (page 117)

Note: this model does not include an O-ring behind the flange, it ensures only IP61 protection index. Consequently, it is not vacuumtight. Watertightness (when mated) is only ensured with HHG and HCG sockets.

HN● Socket, nut fixing, with earthing tag, key (G or A to K), watertight or vacuumtight

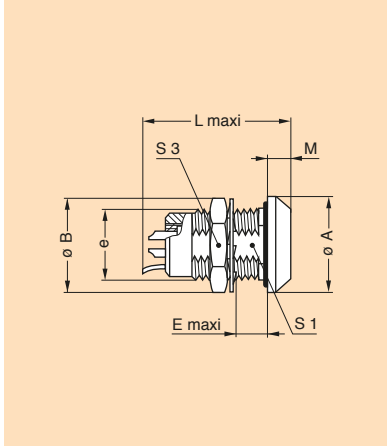

Reference		Dimensions (mm)							
Model	Series	A	B	e	E	L	M	S1	S3
HN●	0B	13	12.4	M9x0.6	7	21.5	3	8.2	11

P5 Panel cut-out (page 117)

HH● Socket, nut fixing, key (G or A to K), watertight or vacuumtight (watertight when mated)

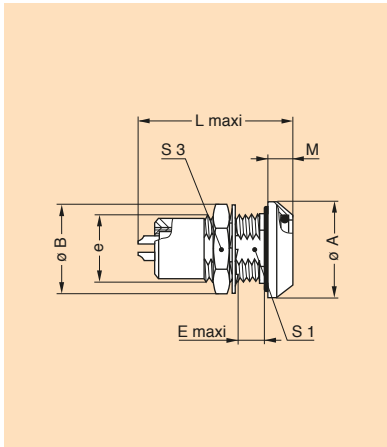

Reference		Dimensions (mm)							
Model	Series	A	B	e	E	L	M	S1	S3
HH●	0B	13	12.4	M9x0.6	7.0	24.5	4.8	8.2	11
HH●	1B	18	15.8	M12x1.0	7.0	30.3	5.2	10.5	14
HH●	2B	22	19.2	M15x1.0	8.0	35.6	6.0	13.5	17
HH●	3B	25	25.0	M18x1.0	11.5	41.3	7.2	16.5	22

P5 Panel cut-out (page 117)

Note: this model ensures watertightness (IP66) in the mating area when mated with FGG or similar plug.



Elbow socket models

XB● Elbow (90°) socket for printed circuit with two nuts, key (G or A or B) (solder, screw or harpoon fixing)

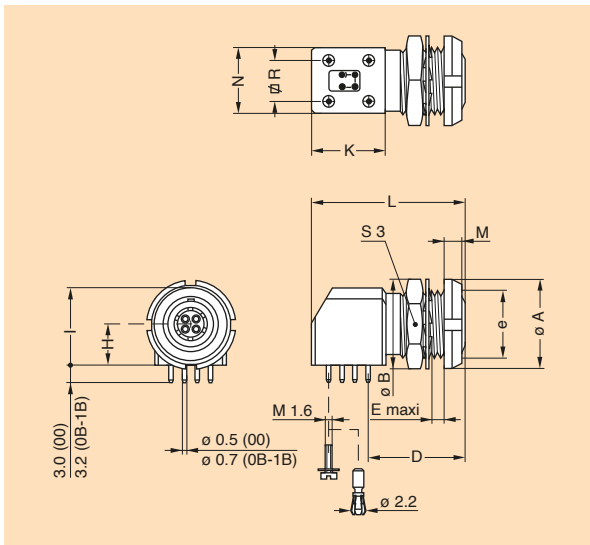
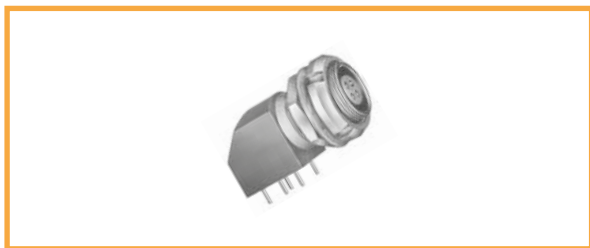

Part number	Dimensions (mm)													
	A	B	D	e	E	H	I	K	L	M	N	R	S3	
XB●.00.302.HLN														
XB●.00.303.HLN	10	10.2	11.5	M7x0.5	2.1	3.5	7.0	8.7	19	2.5	7.1	5.08	9	
XB●.00.304.HLN														

P2 Panel cut-out (page 117)

P10 PCB drilling pattern 00 series (page 122)



Bridge models

Technical characteristics

Mechanical and climatical

Characteristics	Value	Standard
Endurance ¹⁾	> 5000 cycles	IEC 60512-5 test 9a
Working temperature	maximum 90°C	

Note: ¹⁾ see page 133, contact resistance after mating cycles. See page 131, mechanical endurance latching force.

Materials and treatment

Component	Material	Surface treat. (µm)			
		Cu	Ni	Cr	Au
Plastic housing	Polyamide	-			
Metallic parts	Brass	0.5	3	-	-
	Brass	0.5	3	0.3	-
Insulator	PEEK	-			
Male contact	Brass	0.5	3	-	1.0
Female contact	Bronze	0.5	3	-	1.5

Note: the surface treatment standards are as follows:
 - Nickel: SAE AMS QQ N 290, chrome: SAE AMS 2460, gold: ISO 27874

Note:
 the last letter of the part number indicates the colour of the housing.
 Ex. G (standard) is grey. To obtain another colour, replace this letter by the letter corresponding to the selected colour (see table on page 85).

Electrical

Characteristics	Value	Standard
Contact resistance	< 6 mΩ	IEC 60512-2-1 test 2a

Part number	Series	Audio-Mono	Audio-Stereo	Test voltage (kV DC) ¹⁾²⁾	Rated current (A)
CFF.0B.302.PLCG	0B	●	-	1.47	4
CRG.0B.302.PLEG	0B	●	-	1.47	4
CFF.0B.303.PLCG	0B	●	-	1.12	4
CRG.0B.303.PLEG	0B	●	-	1.12	4
CRG.0B.306.PLEG	0B	-	●	0.56	2
CFF.1B.303.PLCG	1B	●	-	1.75	5
CRG.1B.303.PLEG	1B	●	-	1.75	5
CFF.1B.306.PLCG	1B	-	●	1.12	3
CRG.1B.306.PLEG	1B	-	●	1.12	3

Note:
¹⁾ see calculation method, caution and suggested standard on page 134.
²⁾ lowest measured value; contact to contact or contact to shell.

● Special

CFF Bridge plug with two non-latching plugs

CR● Bridge plug with two non-latching plugs, and monitoring socket, key (G or A to K)

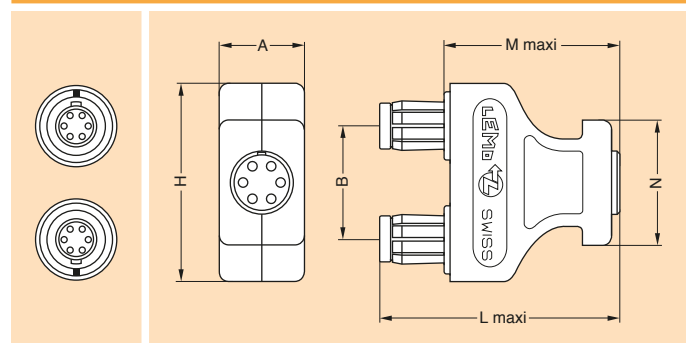
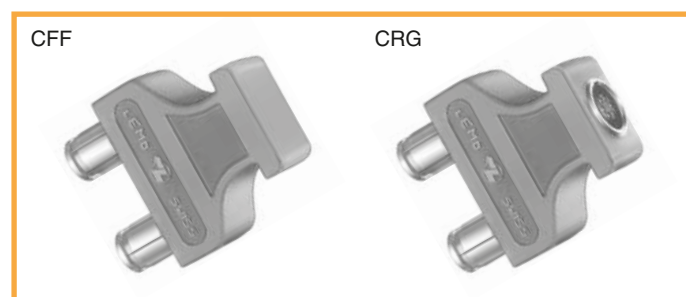

Model	Series	Dimensions (mm)					
		A	B	H	L	M	N
CFF-CR●	0B	13.5	14	27.5	37.2	27.2	22.5
CFF-CR●	1B	15.0	20	35.0	42.0	31.0	22.0

Note: in order to provide the user with a coding system, the bridge plug housing, the double panel washers and the bend reliefs are available in nine colours.

Plastic housing models

These connectors are particularly recommended for all applications requiring maximum electrical insulation when mated. The design, including a latch sleeve and a metal earthing crown, guarantees EMC screening efficiency to meet most requirements.

Technical characteristics

Mechanical and environmental

Characteristics	Value			Standard
	PEEK	PSU	PPSU	
Colour	natural (beige)	white or grey	cream	–
Endurance ¹⁾	> 5000 cycles	> 5000 cycles	> 5000 cycles	IEC 60512-5 test 9a
Humidity	up to 95% at 60°C			–
Temperature range	- 50°C, + 250°C ³⁾	- 50°C, + 150°C	- 50°C, + 180°C	–
Sterilization resistance ²⁾	> 200 cycles	~20 cycles	> 100 cycles	IEC 60601-1 § 44.7
Resistance to solvents	very good	limited	good	–

Note: ¹⁾ see page 133, contact resistance after mating cycles. See page 131, mechanical endurance latching force. ²⁾ Steam sterilization. ³⁾ maximum temperature valid for short periods of use.

FG● Straight plug, key (G or J), cable collet, PEEK outer shell

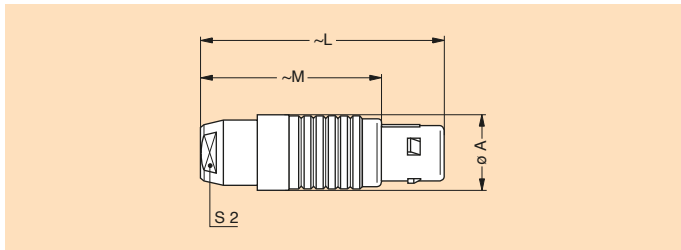

Reference		Dimensions (mm)			
Model	Series	A	L	M	S2
FG●	0B	11.0	37.4	27.4	8
FG●	1B	13.5	43.0	32.0	10
FG●	3B	19.0	62.0	47.0	15
FG●	4B	26.0	78.5	60.5	20

M1 Cable assembly (page 124)

Note: this model is also available with nut for fitting a bend relief in 1B series (for all collet type) and in 4B series (only from collet M82 and up). To order, add a «Z» at the end of the reference. The bend relief must be ordered separately (see page 105).

FGY Straight plug, keys (Y), cable collet and PSU or PPSU outer shell

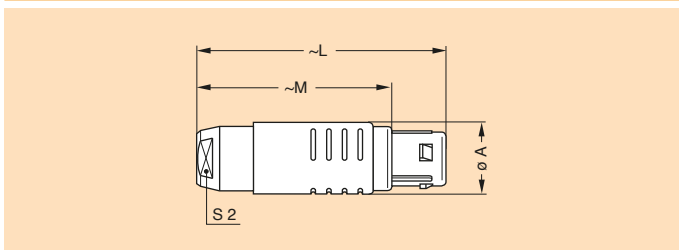

Reference		Dimensions (mm)			
Model	Series	A	L	M	S2
FGY	2B	16.5	50.5	39.5	13
FGY	3B	19.0	58.0	43.0	15
FGY	4B	26.0	76.2	58.2	20

M1 Cable assembly (page 124)

Note: this model is also available with nut for fitting a bend relief in 2B series (only for collet M42 and up), in 3B series (only for collet D62 and up) and in 4B series (only for collet D82 and up). To order, add a «Z» at the end of the reference.
The bend relief must be ordered separately (see page 105).

EN Socket with earthing tag, nut fixing, key (G or J), PEEK outer shell

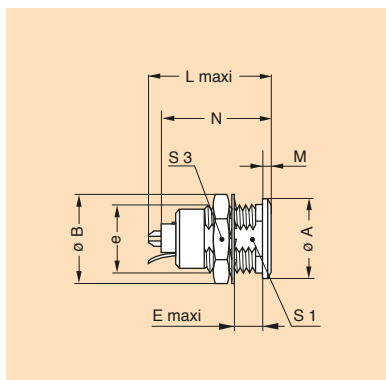

Reference		Dimensions (mm)								
Model	Series	A	B	e	E	L	M	N ¹⁾	S1	S3
EN	0B	11	12.5	M9x0.6	6.4	20.7	1.8	16.5	8.2	11
EN	1B	14	15.8	M12x1.0	7.5	23.0	1.5	21.1	10.5	14
EN	3B	22	25.0	M18x1.0	11.5	30.7	2.0	28.1	16.5	22
EN	4B	28	34.0	M25x1.0	12.0	35.7	2.5	32.6	23.5	30

P1 Panel cut-out (page 117)

Note: ¹⁾ maximum length with crimp contacts.

ENY Socket with earthing tag, nut fixing, keys (Y), PSU or PPSU outer shell

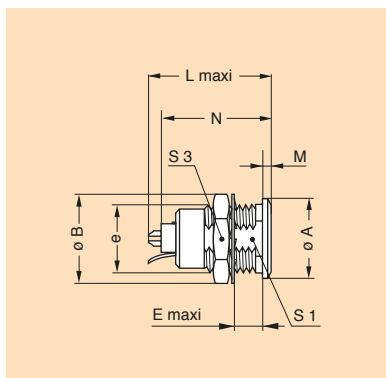

Reference		Dimensions (mm)								
Model	Series	A	B	e	E	L	M	N ¹⁾	S1	S3
ENY	2B	18	19.2	M15x1.0	8.5	26.7	1.8	24.6	13.5	17
ENY	3B	22	25.0	M18x1.0	11.5	30.7	2.0	28.1	16.5	22
ENY	4B	28	34.0	M25x1.0	12.0	35.7	2.5	32.6	23.5	30

P1 Panel cut-out (page 117)

Note: ¹⁾ maximum length with crimp contacts.

Other models with plastic outer shell are available on request.

Alignment key

Alignment key and polarized keying system

B series connector model part numbers are composed of three letters. The LAST LETTER indicates the key position and the contact type (male or female).

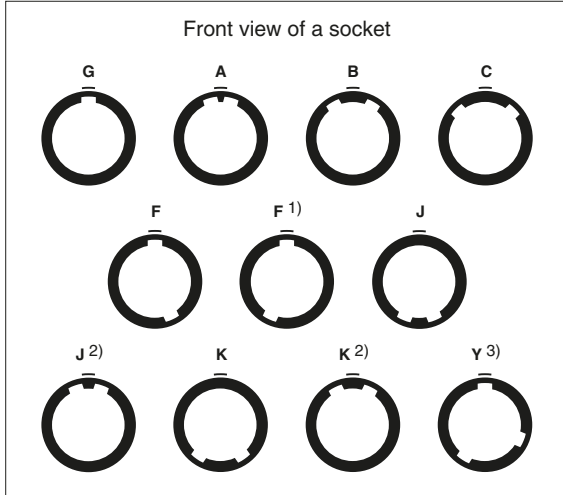

Ref.	Nb of spurs	Series								Contact type	
		00	0B	1B	XB	2B	3B	4B	5B	Plug	Socket
G	1	●	●	●	●	●	●	●	●	male	female
A	2	●	●	●	●	●	●	●	●	male	female
B	2	●	●	●	-	●	●	●	●	male	female
C	2	-	●	●	-	●	●	●	●	male	female
F	2	-	●	●	-	●	●	●	●	male	female
J	2	●	●	●	-	●	●	●	●	female	male
K	2	-	●	●	-	●	●	●	●	female	male
Y	3	-	-	-	-	●	●	●	-	male	female
	3	-	-	-	-	●	●	●	-	male	female

● Standard
● Special

Note: FGY and ENY models are not available with all the keys. Please consult pages corresponding to these models. For R●● models see explanation on page 21 and for S●● models see explanation on page 24.

- Note:**
 1) for 5B series.
 2) for 2B, 3B, 4B and 5B series.
 3) only FGY and ENY models are available (plastic).

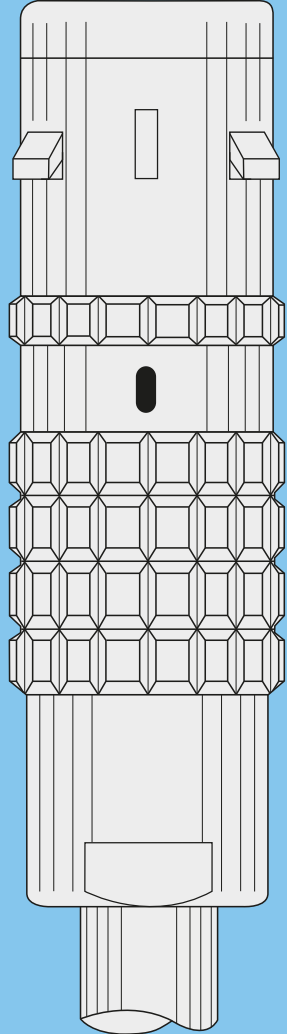
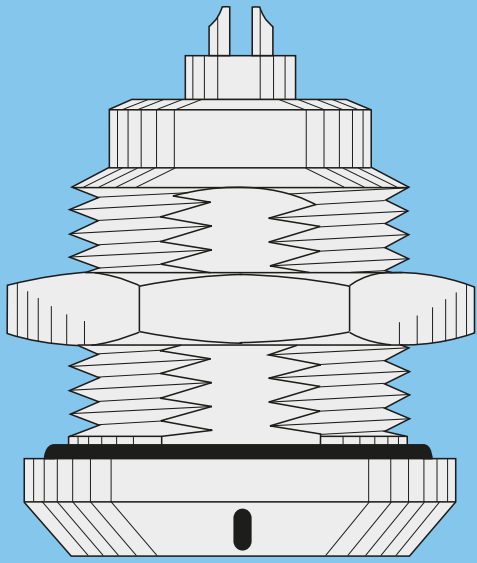

K SERIES (watertight)

K Series

K series connectors have been specifically designed for outdoor applications. They include an inner sleeve and two seals to prevent penetration of solids or liquids into the housing formed by the plug, free socket, fixed socket or coupler. All models (except FX● model) of this series are watertight when mated to give a protection index of IP68 as per IEC 60529 standard (in mated condition) when correctly assembled to an appropriate cable (IP66 otherwise).

K series connectors have the same insulators as the B series and have the following main features:

- security of the Push-Pull latching system
- multipole types 2 to 64 contacts
- keying system («G» key standard) for connector alignment
- 360° screening for full EMC shielding
- rugged housing for extreme working conditions.
- watertight connection (IP68/IP66)
- solder, crimp or print (straight or elbow) contacts
- multiple key options to avoid cross mating of similar connectors
- high packing density for space savings

K series (standard models)

Standard models (page 43)

Fixed plug

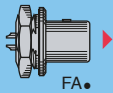

FA.

Straight plug

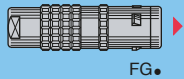

FG.

Sockets

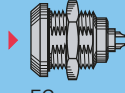

EG.

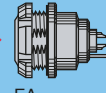

EA.

Free cable socket

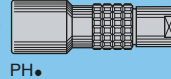

PH.

Fixed cable sockets

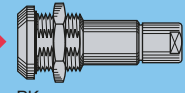

PK.

Elbow plug

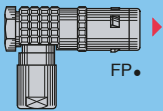

FP.

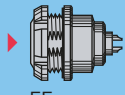

EE.

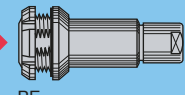

PE.

Watertight or vacuumtight models (page 48)

Sockets

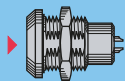

HG.

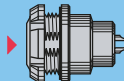

HE.

Elbow socket model (page 49)

Elbow socket

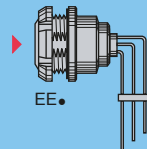

EE.

Part section showing internal components

Fixed socket

- 1 outer shell
- 2 earthing crown
- 3 retaining ring
- 4 hexagonal nut
- 5 insulator
- 6 female contact
- 7 o-ring

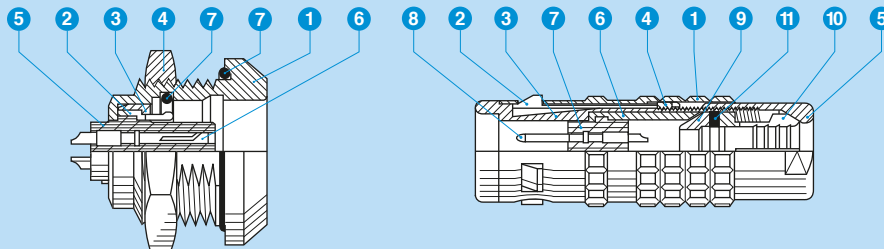

Straight plug

- 1 outer shell
- 2 latch sleeve
- 3 inner shell
- 4 retaining ring
- 5 collet nut
- 6 split insert carrier
- 7 insulator
- 8 male contact
- 9 earthing cone
- 10 collet + washer 1)
- 11 gasket

Note: 1) depending on models.

K series (special models)

Special models (page 50)

Fixed plug

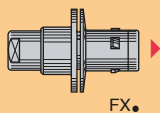

FX.

Straight plugs

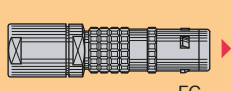

FG.

Sockets

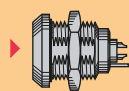

EN.

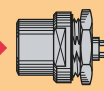

EH.

Free cable socket

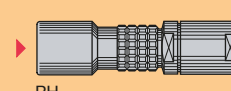

PH.

Elbow plug

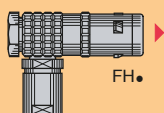

FH.

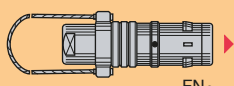

FN.

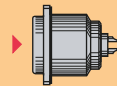

EB.

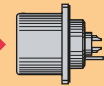

ED.

Watertight or vacuumtight models (page 54)

Socket

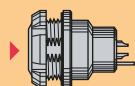

HM.

Fixed coupler

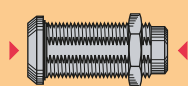

S.

Part numbering system

Standard models part numbering system

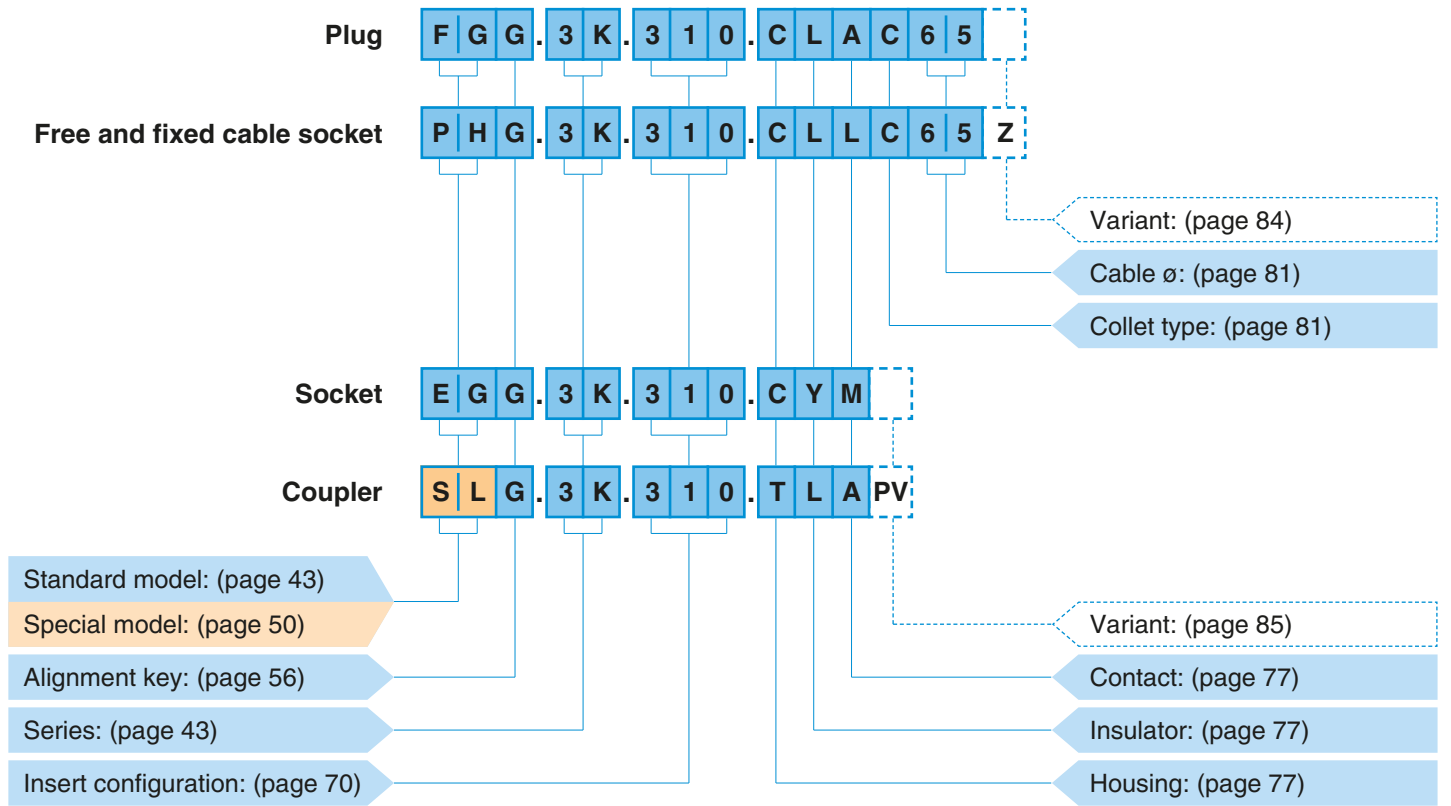

FGG.3K.310.CLAC65 = straight plug with key (G) and cable collet, 3K series, multipole type with 10 contacts, outer shell in chrome-plated brass, PEEK insulator, male solder contacts, C type collet for 6.5 mm diameter cable.

PHG.3K.310.CLLC65Z = free socket with key (G) and cable collet, 3K series, multipole type with 10 contacts, outer shell in chrome-plated brass, PEEK insulator, female solder contacts, C type collet for 6.5 mm diameter cable and nut for fitting a bend relief.

EGG.3K.310.CYM = socket, nut fixing, with key (G), 3K series, multipole type with 10 contacts, outer shell in chrome-plated brass, PEEK extended insulator, female crimp contacts.

SLG.3K.310.TLAPV = fixed coupler, nut fixing, keys (L) on the flange end and key (G) at the other end, 3K series, multipole type with 10 contacts, outer shell in stainless steel, PEEK insulator, male-female contacts, vacuumtight.



Standard models

Technical characteristics

Mechanical and environmental

Characteristics	Value	Standard
Endurance ¹⁾	> 5000 cycles	IEC 60512-5 test 9a
Humidity	up to 95% at 60°C	
Temperature range ^{2) 5)}	- 55°C, + 200°C	
Resistance to vibrations	10-2000 Hz, 15g	IEC 60068-2-6 test Fc
Shock resistance	100 g, 6 ms	IEC 60068-2-27 test Ea
Salt spray corrosion test ⁴⁾	> 1000h	IEC 60068-2-11 test Ka
Protection index (mated) ³⁾	IP68/IP66	IEC 60529
Climatical category	50/175/21	IEC 60068-1

Electrical

Characteristics	Value	Standard	
Shielding efficiency	at 10 MHz	> 95 dB	IEC 60169-1-3 test 9a
	at 1 GHz	> 80 dB	IEC 60169-1-3 test 9a

Note:

the various tests have been carried out with FGG and EGG connector pairs, with chrome-plated brass shell, PEEK insulator and silicone o-ring. Detailed electrical characteristics, as well as materials and treatment are presented in the chapter Technical characteristics on page 130.

¹⁾ see page 133, contact resistance after mating cycles. See page 131, mechanical endurance latching force.

²⁾ minimum operating temperature is -20°C for sockets fitted with an FPM O-ring.

³⁾ IP68 achieved providing that the cable is perfectly circular and that assembly process ensures a high integrity seal.

⁴⁾ for chrome plated product («C» material code).

⁵⁾ maximum temperature valid for short periods of use.

FG● Straight plug, key (G or A to D or L), cable collet

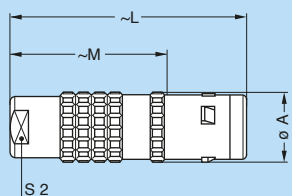

Cable collet and nut for fitting a bend relief ¹⁾

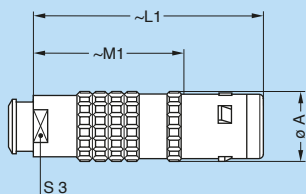

Reference		Dimensions (mm)						
Model	Series	A	L	L1	M	M1	S2	S3
FG●	0K	11	34	34	23.0	23.0	8	7
FG●	1K	13	42	42	28.0	28.0	9	9
FG●	2K	16	52	52	36.0	36.0	12	12
FG●	3K	19	61	60	41.0	40.0	15	15
FG●	4K	25	71	71	50.5	50.5	19	19
FG●	5K	38	92	-	67.0	-	30	-

M1 Cable assembly (page 127)

● Standard ● Special

Note: ¹⁾ to order, add a «Z» at the end of the reference. The bend relief must be ordered separately (see page 105).

FA● Fixed plug, nut fixing, non-latching, key (G or A to D or L)

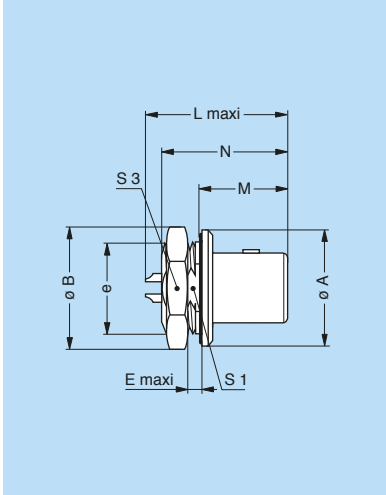

Reference		Dimensions (mm)								
Model	Series	A	B ¹⁾	e	E	L	M	N ²⁾	S1	S3
FA●	1K	20	21.5	M16x1.0	2.3	27.6	16.0	22.5	14.5	19
FA●	2K	25	27.0	M20x1.0	4.5	33.6	18.0	28.3	18.5	24
FA●	3K	31	34.0	M24x1.0	4.0	37.6	22.5	33.8	22.5	30
FA●	4K	37	40.5	M30x1.0	4.0	35.3	23.0	36.3	28.5	36
FA●	5K	55	54.0	M45x1.5	4.0	43.5	28.5	42.3	42.5	–

P1 Panel cut-out (page 118)

Note:

¹⁾ the 1K series is delivered with a locking washer.

The 5K series is delivered with a round nut.

²⁾ maximum length with crimp contacts.

● Standard ● Special

FP● Elbow (90°) plug, key (G or A to D or L), cable collet

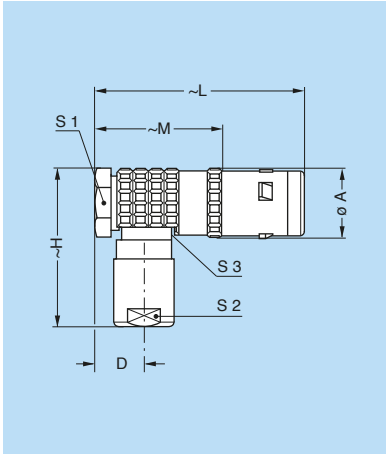

Reference		Dimensions (mm)							
Model	Series	A	D	H	L	M	S1	S2	S3
FP●	0K	11	7.3	25	36	25	9	8	8
FP●	1K	13	8.7	33	42	28	11	9	10
FP●	2K	16	10.2	40	51	35	14	12	13

M3 Cable assembly (page 127)

EG● Socket, nut fixing, key (G or A to D or L)

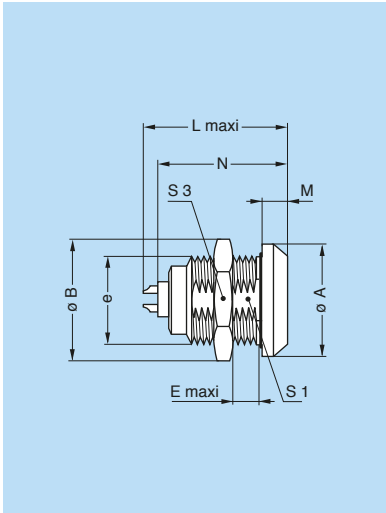

Reference		Dimensions (mm)								
Model	Series	A	B ¹⁾	e	E	L	M	N ²⁾	S1	S3
EG●	0K	18	19.2	M14x1.0	6	21.7	4.0	20.1	12.5	17
EG●	1K	20	21.5	M16x1.0	9	27.0	4.5	25.1	14.5	19
EG●	2K	25	27.0	M20x1.0	9	30.7	5.0	28.6	18.5	24
EG●	3K	31	34.0	M24x1.0	11	36.2	6.0	33.6	22.5	30
EG●	4K	37	40.5	M30x1.0	9	40.2	6.5	38.6	28.5	36
EG●	5K	55	54.0	M45x1.5	10	47.5	9.0	43.6	42.5	–

P1 Panel cut-out (page 118)

Note:

¹⁾ the 5K series is delivered with a round nut.

²⁾ maximum length with crimp contacts.

● Standard ● Special

EE● Socket, nut fixing, key (G or A to D or L) (back panel mounting)

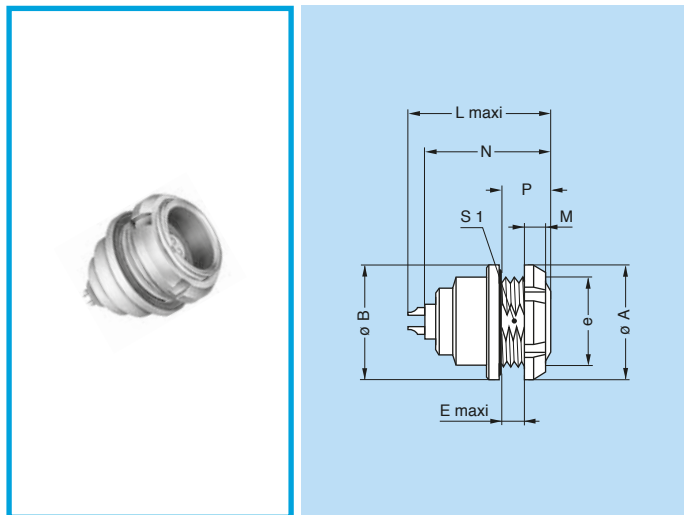

Reference		Dimensions (mm)								
Model	Series	A ¹⁾	B	e	E	L	M	N ²⁾	P	S1
EE●	0K	18.0	18	M14x1.0	3.4	21.7	3.5	20.1	7.0	12.5
EE●	1K	20.0	20	M16x1.0	6.2	27.0	3.5	25.1	10.0	14.5
EE●	2K	25.0	25	M20x1.0	5.0	30.7	3.5	28.6	10.0	18.5
EE●	3K	30.0	31	M24x1.0	7.5	36.2	4.5	33.6	12.0	22.5
EE●	4K	41.5	37	M30x1.0	6.0	40.2	7.0	38.6	13.5	28.5

P1 Panel cut-out (page 118)

Note:
 1) the 3K and 4K series are delivered with a conical nut.
 2) maximum length with crimp contacts.

● Standard ● Special

EA● Socket with earthing tag, nut fixing, key (G or A to D or L) (back panel mounting)

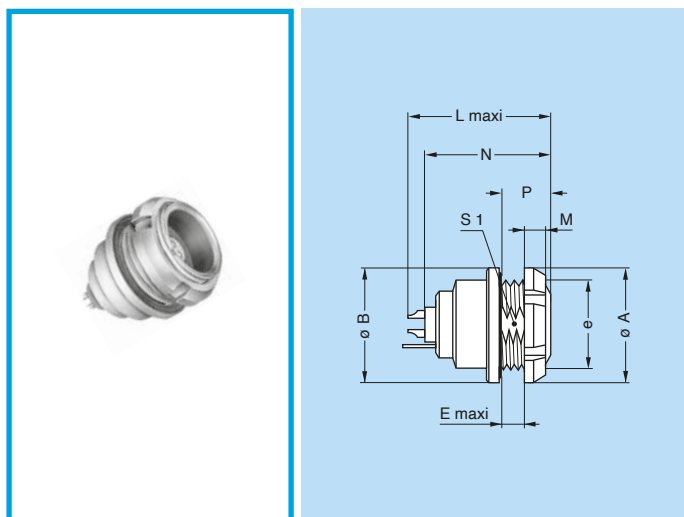

Reference		Dimensions (mm)								
Model	Series	A ¹⁾	B	e	E	L	M	N ²⁾	P	S1
EA●	0K	18.0	18	M14x1.0	3.4	21.7	3.5	20.1	7.0	12.5
EA●	1K	20.0	20	M16x1.0	6.2	27.0	3.5	25.1	10.0	14.5
EA●	2K	25.0	25	M20x1.0	5.0	30.7	3.5	28.6	10.0	18.5
EA●	3K	30.0	31	M24x1.0	7.5	36.2	4.5	33.6	12.0	22.5
EA●	4K	41.5	37	M30x1.0	6.0	40.2	7.0	38.6	13.5	28.5

P1 Panel cut-out (page 118)

Note:
 1) the 3K and 4K series are delivered with a conical nut.
 2) maximum length with crimp contacts.

● Standard ● Special

PH● Free cable socket, key (G or A to D or L), cable collet

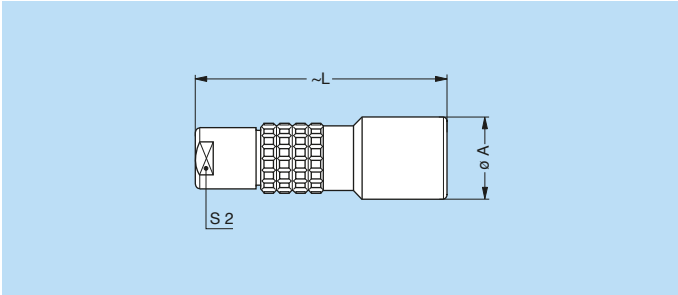

Cable collet and nut for fitting a bend relief ¹⁾

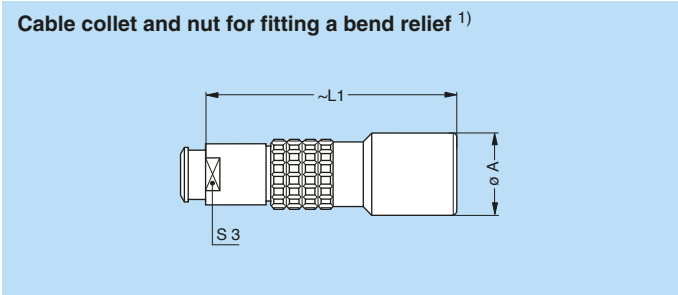

Reference		Dimensions (mm)				
Model	Series	A	L	L1	S2	S3
PH●	0K	13	34.0	34.0	8	7
PH●	1K	15	45.0	45.0	9	9
PH●	2K	19	54.0	54.0	12	12
PH●	3K	23	65.0	64.0	15	15
PH●	4K	29	75.5	75.5	19	19
PH●	5K	42	95.0	–	30	–

M1 Cable assembly (page 127)

● Standard ● Special

Note: ¹⁾ to order, add a «Z» at the end of the reference. The bend relief must be ordered separately (see page 105).

PK● Fixed cable socket, nut fixing, key (G or A to D or L), cable collet

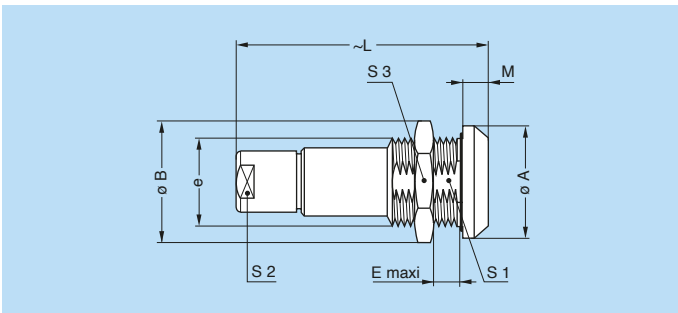

Reference		Dimensions (mm)								
Model	Series	A	B ¹⁾	e	E	L	M	S1	S2	S3
PK●	0K	18	19.2	M14x1.0	9.0	35.2	4.0	12.5	8	17
PK●	1K	20	21.5	M16x1.0	9.5	46.2	4.5	14.5	9	19
PK●	2K	25	27.0	M20x1.0	9.0	54.5	5.0	18.5	12	24
PK●	3K	31	34.0	M24x1.0	11.5	65.7	6.0	22.5	15	30
PK●	4K	37	40.5	M30x1.0	9.0	75.5	6.5	28.5	19	36
PK●	5K	55	54.0	M45x1.5	15.0	98.0	9.0	42.5	30	–

P1 Panel cut-out (page 118)

M1 Cable assembly (page 127)

Note: ¹⁾ the 5K series is delivered with a round nut.

● Standard ● Special

PE● Fixed cable socket, nut fixing, key (G or A to D or L), cable collet (back panel mounting)

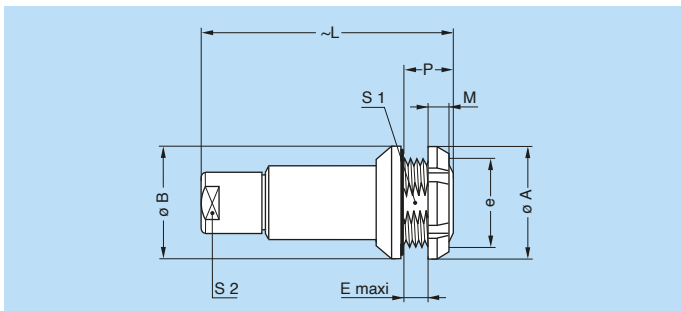

Reference		Dimensions (mm)								
Model	Series	A ¹⁾	B	e	E	L	M	P	S1	S2
PE●	0K	18	18	M14x1.0	5.0	34	3.5	8.5	12.5	8
PE●	1K	20	20	M16x1.0	6.5	45	3.5	10.0	14.5	9
PE●	2K	25	25	M20x1.0	4.0	54	3.5	7.5	18.5	12
PE●	3K	30	31	M24x1.0	7.5	65	4.5	12.0	22.5	15

P1 Panel cut-out (page 118)

M1 Cable assembly (page 127)

Note: ¹⁾ the 3K series is delivered with a conical nut.

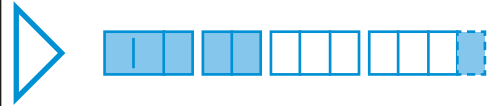

Watertight or vacuumtight models

These socket and coupler models allow the device on which they are fitted to reach a protection index of IP68 as per IEC 60529. They are fully compatible with plugs of the same series and are widely used for portable radios, military, laboratory equipment, aviation, etc.

Watertight models are identified by a letter «P» at the end of the reference.

Most of these models are also available in a vacuumtight version. Such models are identified by the letters «PV» at the end of the part number (certificate on request).

Technical characteristics

Mechanical and environmental

Characteristics	Value	Standard
Endurance ¹⁾	> 5000 cycles	IEC 60512-5 test 9a
Humidity	up to 95% at 60°C	
Temperature range	0K-1K	- 20°C, + 100°C
	2K to 5K	- 20°C, + 80°C
Salt spray corrosion test ⁴⁾	> 1000h	IEC 60068-2-11 test Ka
Climatical category	20/80/21	IEC 60068-1
Leakage rate (He) ²⁾	< 10 ⁻⁷ mbar.l.s ⁻¹	IEC 60512-2-17 test Qk

Characteristics	Value	Standard	
Maximum operating pressure ³⁾	0K	60 bar	IEC 60512-7 test 14d
	1K	60 bar	IEC 60512-7 test 14d
	2K	40 bar	IEC 60512-7 test 14d
	3K	30 bar	IEC 60512-7 test 14d
	4K	15 bar	IEC 60512-7 test 14d
	5K	5 bar	IEC 60512-7 test 14d

Note: ¹⁾ see page 133, contact resistance after mating cycles. See page 131, mechanical endurance latching force.

²⁾ only for vacuumtight models. Residual traces of grease used during (He) leak testing are on the O-ring. Please contact us for further details.

³⁾ this value corresponds to the maximum allowed pressure difference for the assembled socket. ⁴⁾ for chrome plated product («C» material code).

HG● Socket, nut fixing, key (G or A to D or L), watertight or vacuumtight

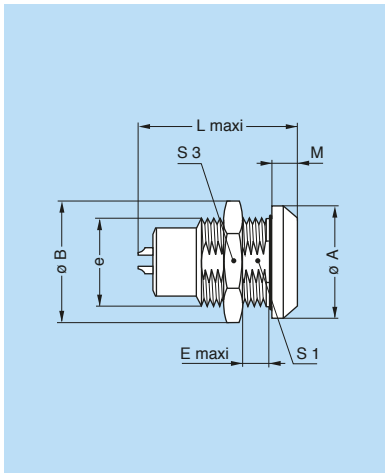

Reference		Dimensions (mm)							
Model	Series	A	B ¹⁾	e	E	L	M	S1	S3
HG●	0K	18	19.2	M14x1.0	5.5	23.0	4.0	12.5	17
HG●	1K	20	21.5	M16x1.0	9.0	30.0	4.5	14.5	19
HG●	2K	25	27.0	M20x1.0	13.0	33.7	5.0	18.5	24
HG●	3K	31	34.0	M24x1.0	16.0	41.7	6.0	22.5	30
HG●	4K	37	40.5	M30x1.0	14.0	49.2	6.5	28.5	36
HG●	5K	55	54.0	M45x1.5	10.0	55.7	9.0	42.5	–

P1 Panel cut-out (page 118)

Note: ¹⁾ the 5K series is delivered with a round nut.

● Standard ● Special

HE● Socket, nut fixing, key (G or A to D or L), watertight or vacuumtight (back panel mounting)

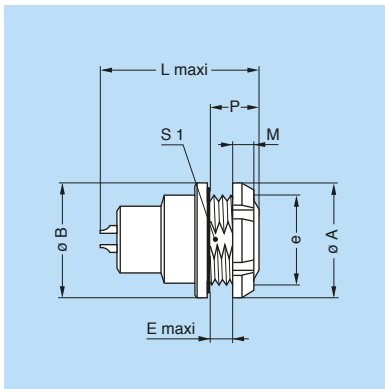

Reference		Dimensions (mm)							
Model	Series	A	B	e	E	L	M	P	S1
HE●	0K	18	18	M14x1.0	3.4	23.0	3.5	7	12.5
HE●	1K	20	20	M16x1.0	6.2	30.6	3.5	10	14.5
HE●	2K	25	25	M20x1.0	5.0	33.7	3.5	10	18.5

P1 Panel cut-out (page 118)



Elbow socket models

EE● Elbow socket for printed circuit, nut fixing, key (G or A to D) with elbow (90°) contacts (back panel mounting)

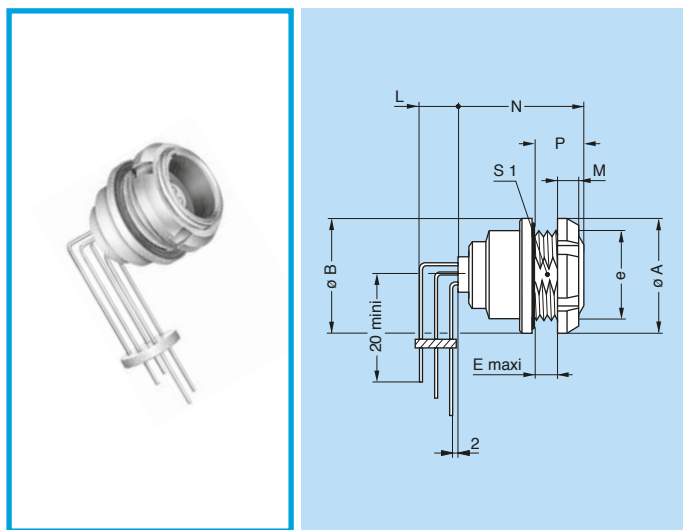

Reference		Dimensions (mm)							
Model	Series	A ¹⁾	B	e	E	M	N	P	S1
EE●	0K	18	18	M14x1.0	3.4	3.5	19.3	7	12.5
EE●	1K	20	20	M16x1.0	6.2	3.5	24.3	10	14.5
EE●	2K	25	25	M20x1.0	5.0	3.5	26.6	10	18.5
EE●	3K	30	31	M24x1.0	7.5	4.5	31.3	12	22.5

P1 Panel cut-out (page 118)

P9 PCB drilling pattern (page 121)

Note: length «L» depends on the number of contacts, see PCB drilling pattern page 121.

Note: ¹⁾ the 3K series is delivered with a conical nut.

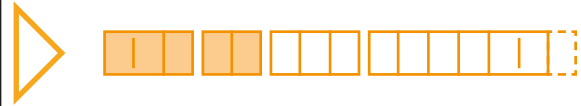

Special models

Technical characteristics

Mechanical and environmental

Characteristics	Value	Standard
Endurance ¹⁾	> 5000 cycles	IEC 60512-5 test 9a
Humidity	up to 95% at 60°C	
Temperature range ^{2) 6)}	- 55°C, + 200°C	
Resistance to vibrations	10-2000 Hz, 15g	IEC 60068-2-6 test Fc
Shock resistance	100 g, 6 ms	IEC 60068-2-27 test Ea
Salt spray corrosion test ⁴⁾	> 1000h	IEC 60068-2-11 test Ka
Protection index (mated) ^{3) 5)}	IP68/IP66	IEC 60529
Climatical category	50/175/21	IEC 60068-1

Electrical

Characteristics	Value	Standard	
Shielding efficiency	at 10 MHz	> 95 dB	IEC 60169-1-3 test 9a
	at 1 GHz	> 80 dB	IEC 60169-1-3 test 9a

Note:

the various tests have been carried out with FGG and EGG connector pairs, with chrome-plated brass shell, PEEK insulator and silicone o-ring. Detailed electrical characteristics, as well as materials and treatment are presented in the chapter Technical characteristics on page 130.

¹⁾ see page 133, contact resistance after mating cycles. See page 131, mechanical endurance latching force.

²⁾ minimum operating temperature is -20°C for sockets fitted with an FPM O-ring.

³⁾ IP68 achieved providing that the cable is perfectly circular and that assembly process ensures a high integrity seal.

⁴⁾ for chrome plated product (« C » material code).

⁵⁾ except FX● model.

⁶⁾ maximum temperature valid for short periods of use.

FG● Straight plug, key (G or A to D or L), cable collet and oversize cable collet ¹⁾

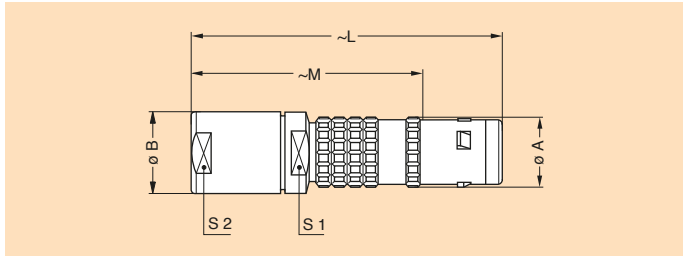

Reference		Dimensions (mm)					
Model	Series	A	B	L	M	S1	S2
FG●	1K	13	14.5	60.0	46	12	12
FG●	2K	16	17.0	68.0	52	15	15
FG●	3K	19	22.0	85.0	65	19	19
FG●	4K	25	36.0	119.5	99	30	32

M2 Cable assembly (page 128)

Note: ¹⁾ correspond to K type of collet, the fitting of oversize collets onto this model allows them to be fitted to the cables that can be accommodated by the next housing size up (see page 81).

FNG Straight plug, key (G or A to D or L), cable collet and lanyard release

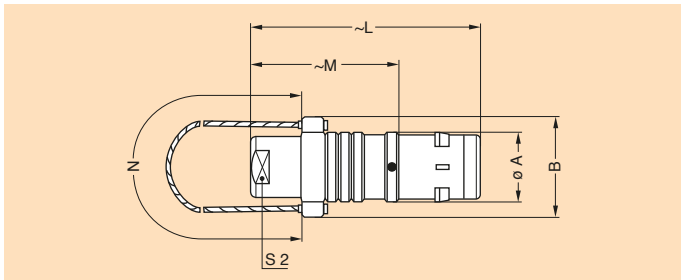

Reference		Dimensions (mm)					
Model	Series	A	B	L	M	N	S2
FN	2K	16	22	52	36.0	160	12
FN	4K	25	32	71	50.5	230	19

M1 Cable assembly (page 127)

Note: cable material: stainless steel with Polyamide sheath

FX Fixed plug with round flange, key (G or A to D or L) and screw fixing

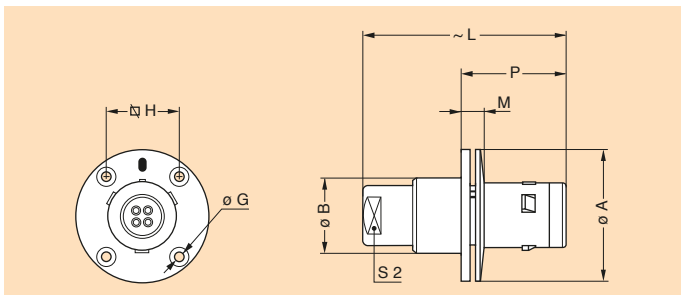

Reference		Dimensions (mm)							
Model	Series	A	B	G	H	L	M	P	S2
FX	3K	38	22.5	3.4	20.6	61	10.0	30.0	15
FX	4K	47	28.5	3.4	27.0	71	11.0	32.0	19
FX	5K	65	42.5	4.4	38.0	100	12.5	38.5	30

P2 Panel cut-out (page 118)

Note: this model does not include an O-ring behind the flange, it allows the device on which it is fitted to reach only IP50 protection index. It does not have a cable collet.

FH Elbow (90°) plug, key (G or A to D or L), cable collet

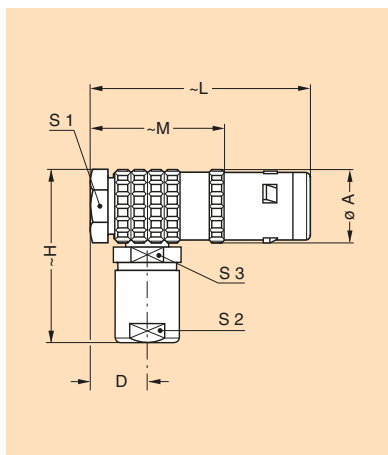

Reference		Dimensions (mm)							
Model	Series	A	D	H	L	M	S1	S2	S3
FH	3K	21.0	11.5	47	60	40.0	18	15	16
FH	4K	27.5	15.5	57	72	51.5	24	19	22

M3 Cable assembly (page 127)

EN● Socket, nut fixing, key (G or A to D or L) and earthing tag

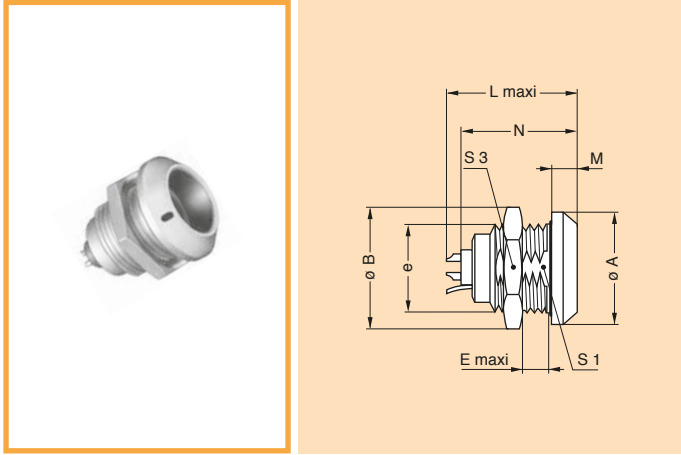

Reference		Dimensions (mm)								
Model	Series	A	B	e	E	L	M	N ¹⁾	S1	S3
EN●	3K	31	34	M24x1.0	11.3	36.2	6	33.6	22.5	30

P1 Panel cut-out (page 118)

Note: ¹⁾ maximum length with crimp contacts.

EB● Socket with square flange, key (G or A to D or L) and screw fixing

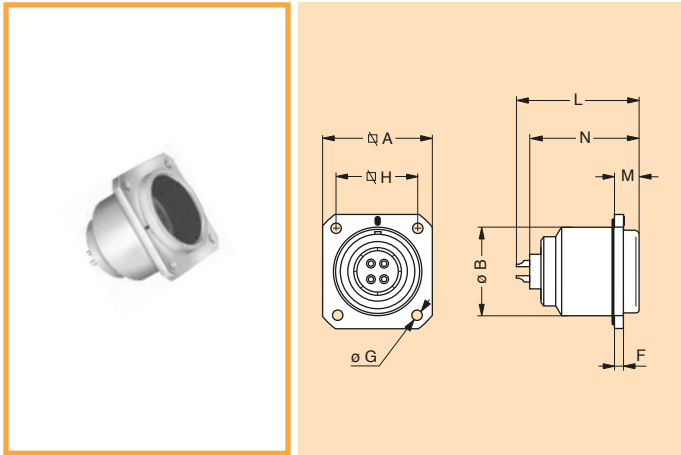

Reference		Dimensions (mm)								
Model	Series	A	B	F	G	H	L	M	N ¹⁾	
EB●	3K	29	23	3	3.4	23	36.2	6.0	32.6	
EB●	4K	37	30	3	3.4	29	40.2	6.5	36.6	
EB●	5K	54	45	4	4.4	44	47.5	8.0	42.1	

P3 Panel cut-out (page 118)

Note: ¹⁾ maximum length with crimp contacts.

ED● Socket with square flange, key (G or A to D or L), protruding shell and earthing tag, screw fixing

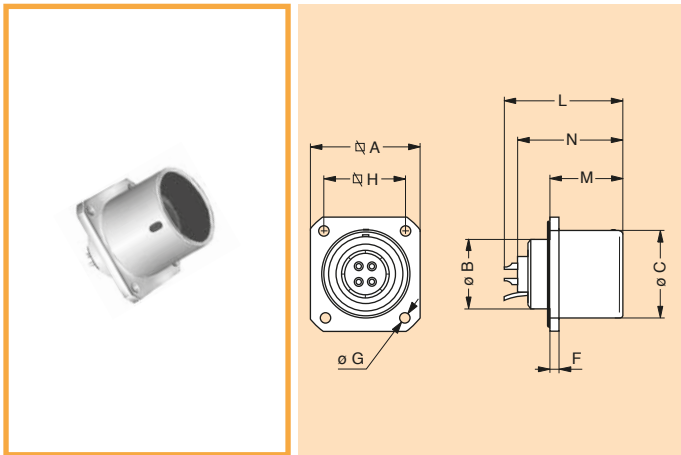

Reference		Dimensions (mm)								
Model	Series	A	B	C	F	G	H	L	M	N ¹⁾
ED●	3K	29	18	23	3	3.4	23	36.2	22.5	32.6

P3 Panel cut-out (page 118)

Note: ¹⁾ maximum length with crimp contacts.

EH● Socket, nut fixing, key (G or A to D or L), protruding shell

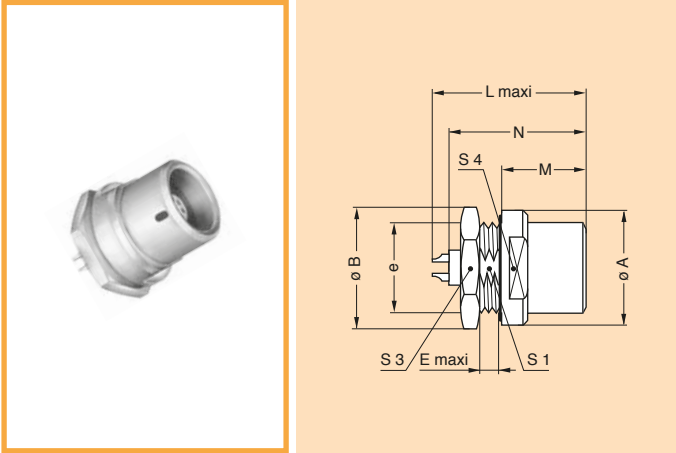

Reference		Dimensions (mm)									
Model	Series	A	B	e	E	L	M	N ¹⁾	S1	S3	S4
EH●	0K	18	19.2	M14x1.0	1.5	21.7	10.5	20.1	12.5	17	15
EH●	1K	20	21.5	M16x1.0	1.5	27.0	15.5	25.1	14.5	19	17
EH●	2K	25	27.0	M20x1.0	1.5	30.7	17.0	27.1	18.5	24	20

P1 Panel cut-out (page 118)

Note: ¹⁾ maximum length with crimp contacts.

PH● Free cable socket, key (G or A to D or L), cable collet and oversize cable collet ¹⁾

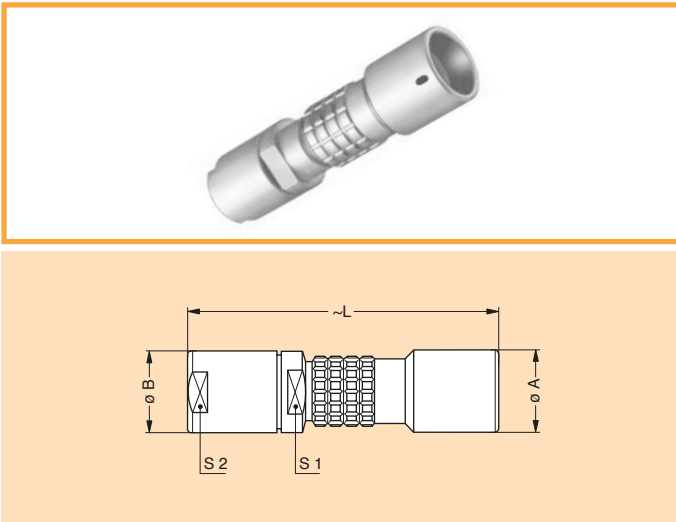

Reference		Dimensions (mm)				
Model	Series	A	B	L	S1	S2
PH●	1K	15	14.5	63	12	12
PH●	2K	19	17.0	70	15	15
PH●	3K	23	22.0	89	19	19
PH●	4K	29	36.0	124	30	32

M2 Cable assembly (page 128)

Note: ¹⁾ correspond to K type of collet, the fitting of oversize collets onto this model allows them to be fitted to the cables that can be accommodated by the next housing size up (see page 81).

▶ Watertight or vacuumtight models

These socket and coupler models allow the device on which they are fitted to reach a protection index of IP68 as per IEC 60529. They are fully compatible with plugs of the same series and are widely used for portable radios, military, laboratory equipment, aviation, etc.

Watertight models are identified by a letter «P» at the end of the reference.

Most of these models are also available in a vacuumtight version. Such models are identified by the letters «PV» at the end of the part number (certificate on request).

Technical characteristics

Mechanical and environmental

Characteristics	Value	Standard
Endurance ¹⁾	> 5000 cycles	IEC 60512-5 test 9a
Humidity	up to 95% at 60°C	
Temperature range	1K	- 20°C, + 100°C
	2K to 5K	- 20°C, + 80°C
Salt spray corrosion test ⁴⁾	> 1000h	IEC 60068-2-11 test Ka
Climatical category	20/80/21	IEC 60068-1
Leakage rate (He) ²⁾	< 10 ⁻⁷ mbar.l.s ⁻¹	IEC 60512-2-17 test Qk

Characteristics	Value	Standard	
Maximum operating pressure ³⁾	1K	60 bar	IEC 60512-7 test 14d
	2K	40 bar	IEC 60512-7 test 14d
	3K	30 bar	IEC 60512-7 test 14d
	4K	15 bar	IEC 60512-7 test 14d
	5K	5 bar	IEC 60512-7 test 14d

Note: ¹⁾ see page 133, contact resistance after mating cycles. See page 131, mechanical endurance latching force.

²⁾ only for vacuumtight models. Residual traces of grease used during (He) leak testing are on the O-ring. Please contact us for further details.

³⁾ this value corresponds to the maximum allowed pressure difference for the assembled socket. ⁴⁾ for chrome plated product («C» material code).

HM● Socket with earthing tag, nut fixing, key (G or A to D or L), watertight or vacuumtight (back panel mounting)

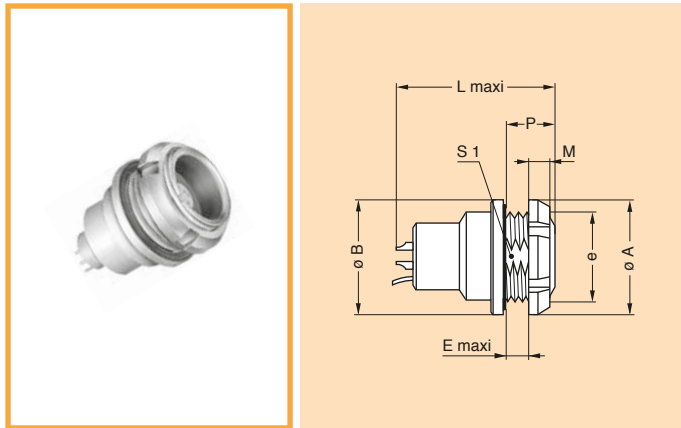

Reference		Dimensions (mm)							
Model	Series	A	B	e	E	L	M	P	S1
HM●	1K	20	20	M16x1.0	6.2	30.0	3.5	10	14.5
HM●	2K	25	25	M20x1.0	5.0	33.7	3.5	10	18.5

P1 Panel cut-out (page 118)

S●● Fixed coupler, nut fixing, key (G or L) at the flange end, and key (G or C or L) at the other end, watertight or vacuumtight

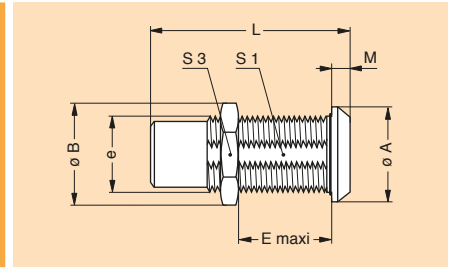
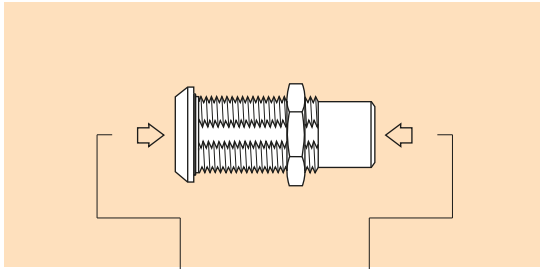

G		SGL		L
L		SLG		G
L		SLC		C

Example

Alignment key see page 56.

Reference		Contacts Type	Dimensions (mm)							
Model	Series		A	B ¹⁾	e	E	L	M	S1	S3
SGL	2K	female – male	25	27.0	M20x1.0	25	52.4	5.0	18.5	24
SLG	2K	male – female	25	27.0	M20x1.0	25	52.4	5.0	18.5	24
SLG	3K	male – female	31	34.0	M24x1.0	33	64.0	6.0	22.5	30
SLG	4K	male – female	37	40.5	M30x1.0	48	74.0	6.5	28.5	36
SLC	4K	male – female	37	40.5	M30x1.0	48	74.0	6.5	28.5	36
SLG	5K	male – female	55	54.0	M45x1.5	58	88.0	9.0	42.5	–
SLC	5K	male – female	55	54.0	M45x1.5	58	88.0	9.0	42.5	–

P1 Panel cut-out (page 118)

Note: ¹⁾ the 5K series is delivered with a round nut.
For this fixed coupler, the first contact type mentioned is always the one at the flange end.
On request, these couplers can be produced in other series, with other keys.

Alignment key

Alignment key and polarized keying system

K series connector model part numbers are composed of three letters. The LAST LETTER indicates the key position and the contact type (male or female).

Ref.	Nb of spurs	Contact type	
		Plug	Socket
G	1	male	female
A	2	male	female
B	2	male	female
C	2	male	female
D	2	male	female
L	2	female	male

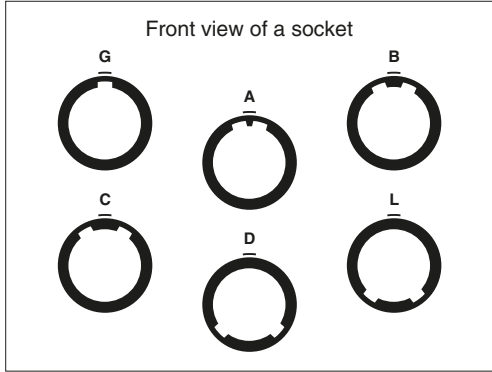

Note: S●● models are not available with all the keys, see explanation on page 55. Please consult the pages corresponding to these models.

- Standard
- Special

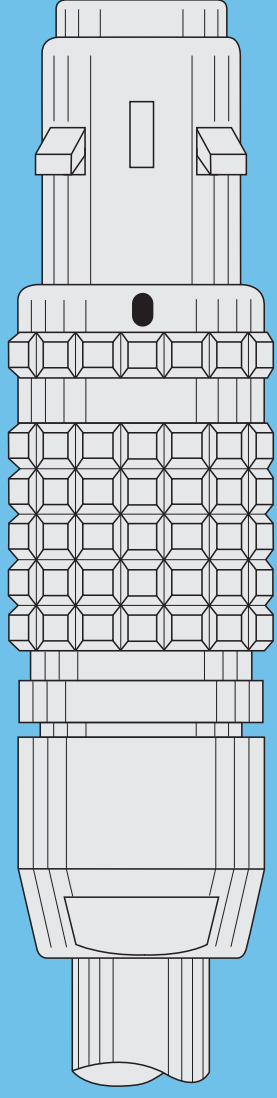
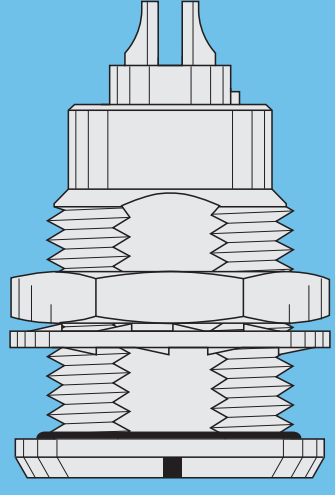

T SERIES (watertight)

T Series

T series connectors have been specifically designed for outdoor applications. They include an inner sleeve and seals to prevent penetration of solids or liquids. This series is watertight when mated to give a protection index of IP68 as per IEC 60529 standard and have the following main features:

- IP68 mated
- Push-Pull self-latching system
- Mechanical key (FGG) with multiple keys to avoid cross-mating
- High packing density for space savings
- 360° shielding for full EMC shielding
- Compatible with existing B sockets
- Same mounting hole as B sockets
- Black-chrome plated brass and plastic outershell available
- Multipole types 2 to 32 contacts
- For cables 1.0 up to 10.5 mm
- Solder, crimp or print contacts

T series (standard models)

Standard models (page 61)

Elbow plug

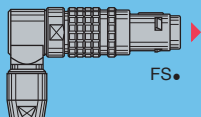

Straight plug

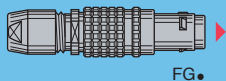

Sockets

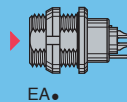
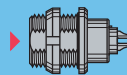
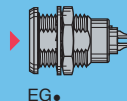

Free cable socket

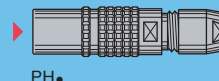

Watertight or vacuumtight models (page 64)

Sockets

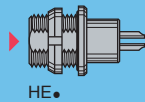
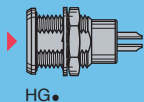

Part section showing internal components

Fixed socket

- 1 outer shell
- 2 earthing crown
- 3 hexagonal nut
- 4 insulator
- 5 female contact
- 6 o-ring
- 7 locking washer

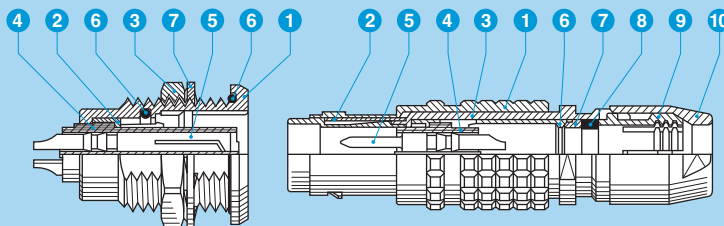

Straight plug

- 1 outer shell
- 2 latch sleeve
- 3 inner shell
- 4 insulator
- 5 male contact
- 6 split insert carrier
- 7 earthing cone
- 8 gasket
- 9 collet
- 10 collet nut

T series (special models)

Special models (page 65)

Fixed plug

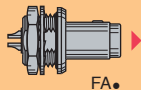

FA•

Straight plugs

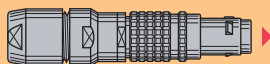

FG•

Free cable socket

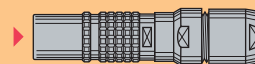

PH•



FF•

Watertight or vacuumtight model (page 66)

Socket

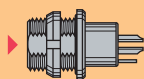

HM•

Plastic housing models (page 67)

Straight plug



FG•

Socket

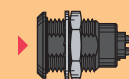

EG•

Part numbering system

Standard models part numbering system

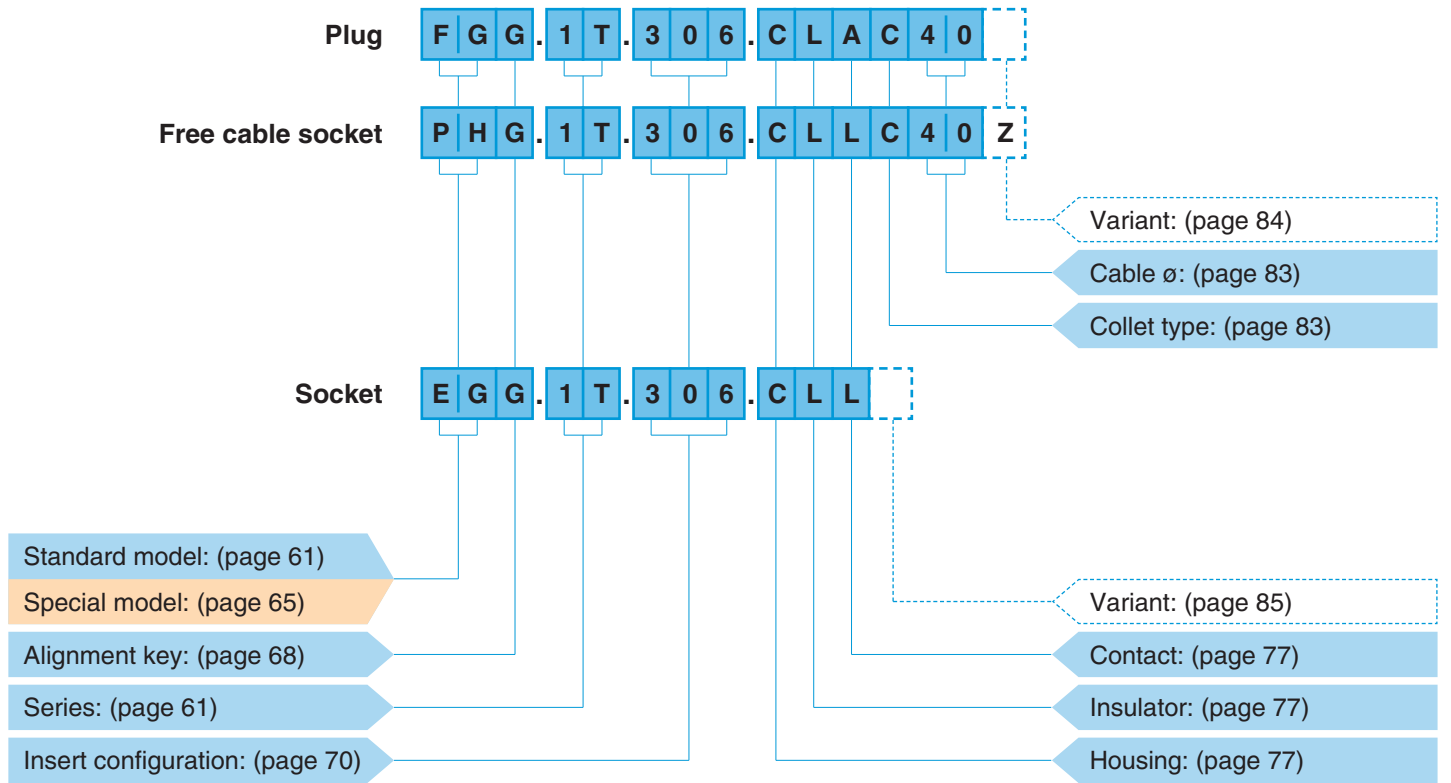

FGG.1T.306.CLAC40 = straight plug with key (G) and cable collet for bend relief, 1T series, multipole type with 6 contacts, outer shell in chrome-plated brass, PEEK insulator, male solder contacts, C type collet for 4.0 mm diameter cable.

PHG.1T.306.CLLC40Z = free cable socket with key (G) and cable collet, 1T series, multipole type with 6 contacts, outer shell in chrome-plated brass, PEEK insulator, female solder contacts, C type collet for 4.0 mm diameter cable and nut for fitting a bend relief.

EGG.1T.306.CLL = socket, nut fixing, with key (G), 1T series, multipole type with 6 contacts, outer shell in chrome-plated brass, PEEK insulator, female solder contacts.



Standard models

Technical characteristics

Mechanical and environmental

Characteristics	Value	Standard
Endurance ¹⁾	> 3000 cycles	IEC 60512-5 test 9a
Humidity	up to 95% at 60°C	
Temperature range ²⁾	- 55°C, + 200°C ⁷⁾ / (- 20°C, + 80°C)	
Resistance to vibrations	10-2000 Hz, 15g	IEC 60068-2-6 test Fc
Shock resistance	100 g, 6 ms	IEC 60068-2-6 test Ea
Salt spray corrosion test ⁶⁾	> 1000h	IEC 60068-2-11 test Ka
Protection index (mated) ³⁾	IP68/IP66	IEC 60529
Latching retention force ^{4) 5)}	From 85 N up to 300 N	
Climatical category	50/175/21	IEC 60068-1

Note:

- ¹⁾ see page 133, contact resistance after mating cycles. See page 131, mechanical endurance latching force.
- ²⁾ operating temperature is -20°C, +80°C for watertight or vacuumtight models fitted with an FPM O-ring and Epoxy.
- ³⁾ IP68 achieved providing that the cable is perfectly circular and that assembly process ensures a high integrity seal.
- ⁴⁾ average value.
- ⁵⁾ depending of the size.
- ⁶⁾ for chrome plated product («C» material code).
- ⁷⁾ maximum temperature valid for short periods of use.

Electrical

Characteristics	Value	Standard	
Shielding efficiency	at 10 MHz	> 75 dB	IEC 60169-1-3 test 9a
	at 1 GHz	> 40 dB	IEC 60169-1-3 test 9a

Note:

the various tests have been carried out with FGG and EGG connector pairs, with chrome-plated brass shell and PEEK insulator. Detailed electrical characteristics, as well as materials and treatment are presented in the chapter Technical characteristics on page 130.

FG● Straight plug, key (G or A to L), cable collet

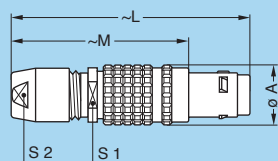

Cable collet and nut for fitting a bend relief ¹⁾

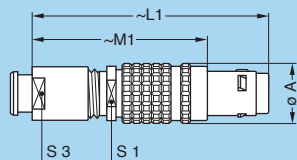

Reference		Dimensions (mm)								Cable ϕ	
Model	Series	A	L	L1	M	M1	S1	S2	S3	min.	max.
FG●	TT	7.0	33.2	32.7	25.2	24.7	5.5	5	6	2.4	3.0
FG●	0T	9.5	39.0	38.0	29.0	28.0	7.5	7	7	1.0	4.5
FG●	1T	12.0	46.0	45.0	35.0	34.0	11.0	9	9	1.3	6.5
FG●	2T	15.0	55.0	54.0	43.0	42.0	14.0	12	12	1.3	8.5
FG●	3T	18.8	64.0	62.0	49.0	47.0	16.0	14	15	2.6	10.5

M1 Cable assembly (page 129)

● Standard ● Special

Note: ¹⁾ to order, add a «Z» at the end of the reference. The bend relief must be ordered separately (see page 105).

FS Adjustable right angle plug, key (G or A to L), cable collet

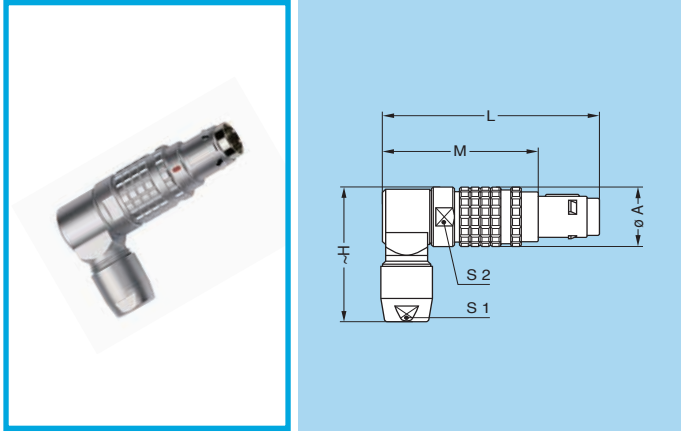

Reference		Dimensions (mm)						Cable ϕ	
Model	Series	A	H	L	M	S1	S2	min.	max.
FS	TT	8	20.0	28.5	20.5	5	7.5	2.4	3.0
FS	0T	10	23.0	36.0	26.0	7	9.5	1.0	4.5
FS	1T	13	30.0	43.5	32.5	9	12.0	1.3	6.5
FS	2T	17	37.5	54.0	42.0	12	16.0	1.3	8.5
FS	3T	20	40.9	63.9	48.9	14	19.0	2.6	10.5

● Standard ● Special

EG Socket, nut fixing, key (G or A to L)

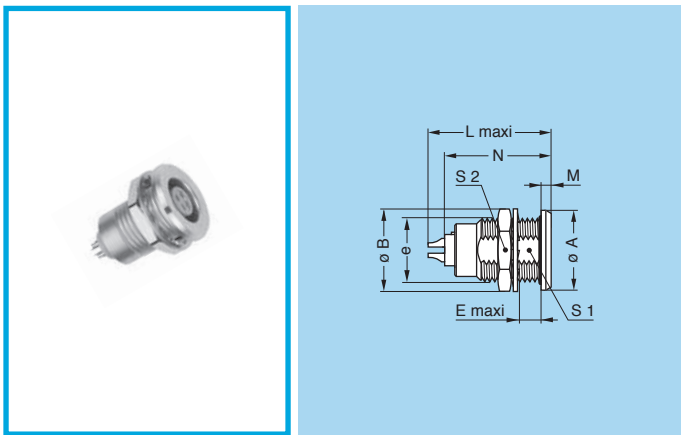

Reference		Dimensions (mm)								
Model	Series	A	B	e	E	L	M	N ¹⁾	S1	S2
EG	TT	10.0	10.2	M7x0.5	5.5	16.0	1.2	13.5	6.3	9
EG	0T	12.0	12.5	M9x0.6	6.0	21.0	1.5	19.1	8.2	11
EG	1T	15.5	16.0	M12x1.0	6.0	23.0	1.8	21.5	10.5	14
EG	2T	18.5	19.6	M15x1.0	7.5	26.5	1.8	24.6	13.5	17
EG	3T	23.5	25.1	M18x1.0	9.6	30.1	2.5	25.0	16.5	22

P1 Panel cut-out (page 117)

Note: ¹⁾ maximum length with crimp contacts.

● Standard ● Special

EE Socket, nut fixing, key (G or A to L) (back panel mounting)

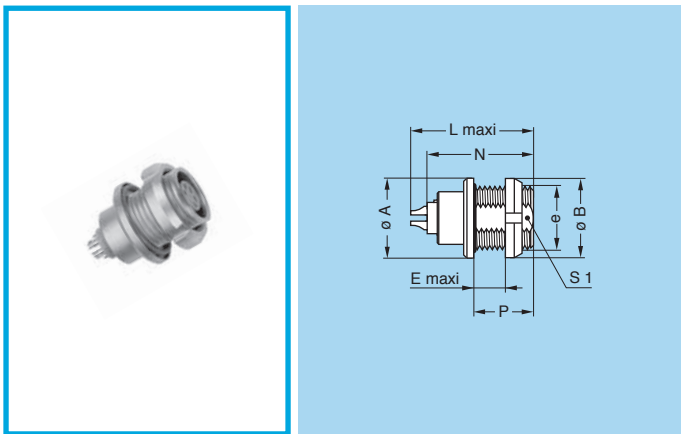

Reference		Dimensions (mm)							
Model	Series	A	B	e	E	L	N ¹⁾	P	S1
EE	TT	10.0	10.0	M7x0.5	4.5	16.0	13.5	7	6.3
EE	0T	12.0	12.0	M9x0.6	6.5	21.0	19.1	9	8.2
EE	1T	15.5	16.0	M12x1.0	6.5	23.0	21.5	10	10.5
EE	2T	18.5	20.0	M15x1.0	7.5	26.5	24.6	11	13.5
EE	3T	23.5	24.0	M18x1.0	7.5	30.1	25.0	12	16.5

P1 Panel cut-out (page 117)

Note: ¹⁾ maximum length with crimp contacts.

● Standard ● Special

EA Socket with earthing tag, nut fixing, key (G or A to L) (back panel mounting)

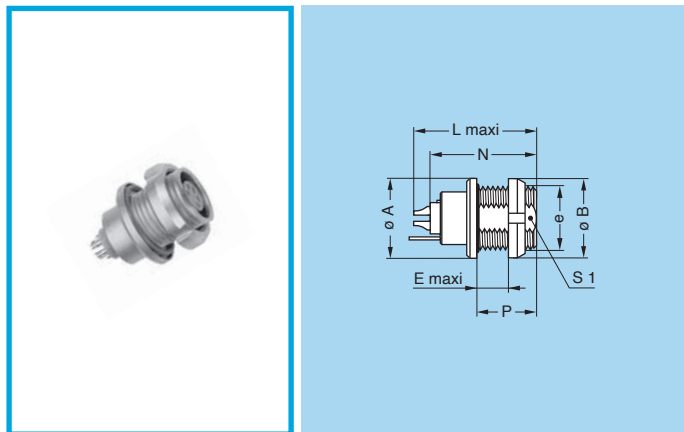

Reference		Dimensions (mm)							
Model	Series	A	B	e	E	L	N ¹⁾	P	S1
EA	TT	10.0	10.0	M7x0.5	4.5	16.0	13.5	7	6.3
EA	0T	12.0	12.0	M9x0.6	6.5	21.0	19.1	9	8.2
EA	1T	15.5	16.0	M12x1.0	6.5	23.0	21.5	10	10.5
EA	2T	18.5	20.0	M15x1.0	7.5	26.5	24.6	11	13.5
EA	3T	23.5	24.0	M18x1.0	7.5	30.1	25.0	12	16.5

P1 Panel cut-out (page 117)

Note: ¹⁾ maximum length with crimp contacts.

● Standard ● Special

PH Free cable socket, key (G or A to L), cable collet

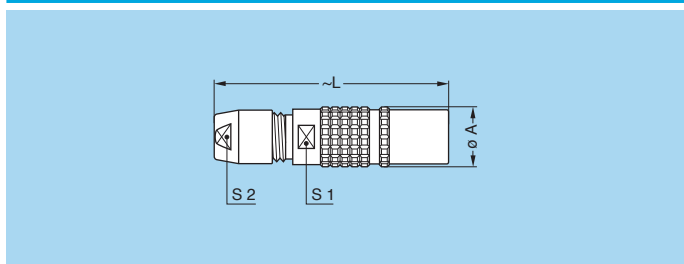

Reference		Dimensions (mm)						Cable ø	
Model	Series	A	L	L1	S1	S2	S3	min.	max.
PH	TT	7.0	32.0	31.5	5.5	5	6	2.4	3.0
PH	0T	9.5	38.0	37.0	8.0	7	7	1.0	4.5
PH	1T	12.0	43.5	42.5	10.0	9	9	1.3	6.5
PH	2T	15.0	52.0	51.0	13.0	12	12	1.3	8.5
PH	3T	18.8	61.5	60.0	16.0	14	15	2.6	10.5

M1 Cable assembly (page 129)

● Standard ● Special

Cable collet and nut for fitting a bend relief ¹⁾

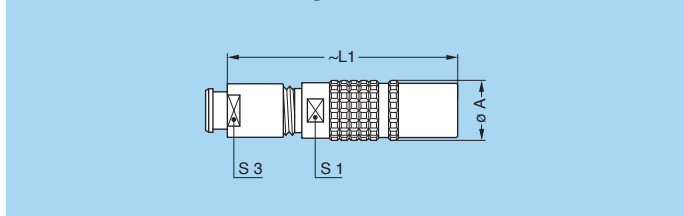

Note: ¹⁾ to order, add a «Z» at the end of the reference. The bend relief must be ordered separately (see page 105).

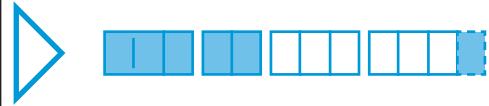

Watertight or vacuumtight models

Watertight models are identified by a letter «P» at the end of the reference. Most of these models are also available in a vacuumtight version. Such models are identified by the letters «PV» at the end of the part number (certificate on request).

Part number example

HGG.0T.305.CLLP (5 contacts, resin potted) / HGG.0T.305.CLLPV (5 contacts, resin potted and vacuumtight tested)

Technical characteristics

Mechanical and environmental

Characteristics	Value	Standard
Endurance ¹⁾	> 3000 cycles	IEC 60512-5 test 9a
Humidity	up to 95% at 60°C	
Temperature range ²⁾	-20°C, +80°C	
Resistance to vibrations	10-2000 Hz, 15g	IEC 60068-2-6 test Fc
Shock resistance	100 g, 6 ms	IEC 60068-2-27 test Ea
Salt spray corrosion test ⁶⁾	> 1000h	IEC 60068-2-11 test Ka
Protection index (mated) ³⁾	IP68/IP66	IEC 60529
Latching retention force ^{4) 5)}	From 85 N up to 300 N	
Climatical category	50/175/21	IEC 60068-1
Leakage rate (He)	< 10 ⁻⁷ mbar.l.s ⁻¹	IEC 60512-2-17 test Qk

Characteristics	Value	Standard	
Maximum operating pressure ⁷⁾	TT	60 bar	IEC 60512-7 test 14d
	0T	60 bar	IEC 60512-7 test 14d
	1T	60 bar	IEC 60512-7 test 14d
	2T	40 bar	IEC 60512-7 test 14d

Note:

- ¹⁾ see page 133, contact resistance after mating cycles. See page 131, mechanical endurance latching force.
- ²⁾ operating temperature is -20°C, +80°C for watertight or vacuumtight models fitted with an FPM O-ring and Epoxy.
- ³⁾ IP68 achieved providing that the cable is perfectly circular and that assembly process ensures a high integrity seal.
- ⁴⁾ average value.
- ⁵⁾ depending of the size.
- ⁶⁾ for chrome plated product («C» material code).
- ⁷⁾ this value corresponds to the maximum allowed pressure difference for the assembled socket.

HG● Socket, nut fixing, key (G or A to L), watertight or vacuumtight

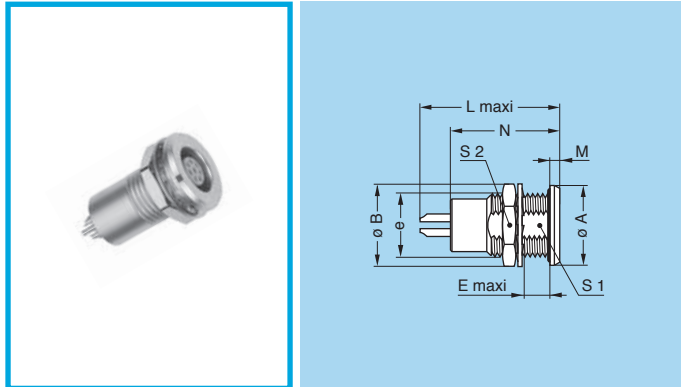

Reference		Dimensions (mm)								
Model	Series	A	B	e	E	L	M	N ¹⁾	S1	S2
HG●	TT	10.0	10.2	M7x0.5	5.5	18.0	1.2	15.0	6.3	9
HG●	0T	12.0	12.5	M9x0.6	6.5	22.0	1.5	18.5	8.2	11
HG●	1T	15.5	16.0	M12x1.0	6.0	26.0	1.8	21.5	10.5	14
HG●	2T	18.5	19.6	M15x1.0	8.0	30.5	1.8	25.0	13.5	17

P5 Panel cut-out (page 117)

● Standard ● Special

HE● Socket, nut fixing, key (G or A to L), watertight or vacuumtight (back panel mounting)

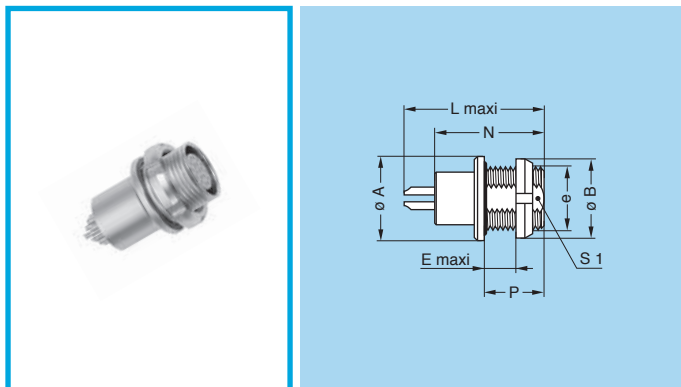

Reference		Dimensions (mm)							
Model	Series	A	B	e	E	L	N	P	S1
HE●	TT	10.0	10.0	M7x0.5	4.5	18.0	15.0	7	6.3
HE●	0T	12.0	12.0	M9x0.6	6.5	22.0	18.5	9	8.2
HE●	1T	15.5	16.0	M12x1.0	6.5	26.0	21.5	10	10.5
HE●	2T	18.5	20.0	M15x1.0	7.5	30.5	25.0	11	13.5

P5 Panel cut-out (page 117)

● Standard ● Special



Special models

Technical characteristics

Mechanical and environmental

Characteristics	Value	Standard
Endurance ¹⁾	> 3000 cycles	IEC 60512-5 test 9a
Humidity	up to 95% at 60°C	
Temperature range ²⁾	- 55°C, + 200°C ⁷⁾ / (- 20°C, + 80°C)	
Resistance to vibrations	10-2000 Hz, 15g	IEC 60068-2-6 test Fc
Shock resistance	100 g, 6 ms	IEC 60068-2-6 test Ea
Salt spray corrosion test ⁶⁾	> 1000h	IEC 60068-2-11 test Ka
Protection index (mated) ³⁾	IP68/IP66	IEC 60529
Latching retention force ^{4) 5)}	From 85 N up to 300 N	
Climatical category	50/175/21	IEC 60068-1

Note:

- ¹⁾ see page 133, contact resistance after mating cycles. See page 131, mechanical endurance latching force.
- ²⁾ operating temperature is -20°C, +80°C for watertight or vacuumtight models fitted with an FPM O-ring and Epoxy.
- ³⁾ IP68 achieved providing that the cable is perfectly circular and that assembly process ensures a high integrity seal.
- ⁴⁾ average value.
- ⁵⁾ depending of the size.
- ⁶⁾ for chrome plated product (« C » material code).
- ⁷⁾ maximum temperature valid for short periods of use.

Electrical

Characteristics	Value	Standard
Shielding efficiency	at 10 MHz	> 75 dB
	at 1 GHz	> 40 dB
		IEC 60169-1-3 test 9a
		IEC 60169-1-3 test 9a

Note:

the various tests have been carried out with FGG and EGG connector pairs, with chrome-plated brass shell and PEEK insulator. Detailed electrical characteristics, as well as materials and treatment are presented in the chapter Technical characteristics on page 130.

FG● Straight plug, key (G or A to L), cable collet and oversize cable collet ¹⁾

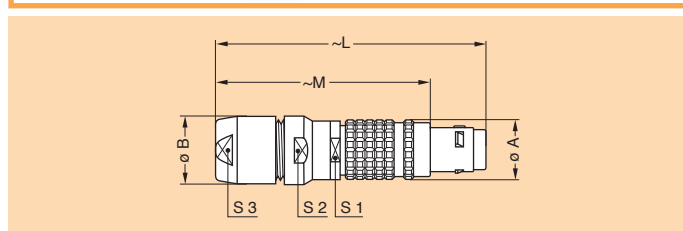

Reference		Dimensions (mm)							Cable ø	
Model	Series	A	B	L	M	S1	S2	S3	min.	max.
FG●	0T	9.5	10.9	50.7	40.9	8.5	10	9	4.6	6.5
FG●	1T	12.0	13.9	60.2	49.1	11.0	13	12	6.6	8.5
FG●	2T	15.0	16.5	69.1	57.0	14.0	15	14	8.6	10.5
FG●	3T	18.8	23.0	87.7	72.7	16.0	20	20	10.6	15.0

M2 Cable assembly (page 129)

Note: ¹⁾ correspond to K type of collet, the fitting of oversize collets onto this model allows them to be fitted to the cables that can be accommodated by the next housing size up (see page 83).

FF● Straight plug, key (G or A to L), non latching, cable collet

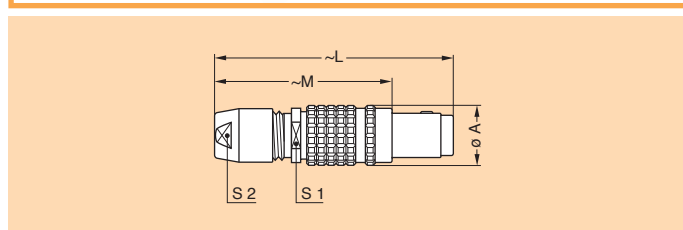

Reference		Dimensions (mm)					Cable ø	
Model	Series	A	L	M	S1	S2	min.	max.
FF●	TT	7.0	33.2	25.2	5.5	5	2.4	3.0
FF●	0T	9.5	39.0	29.0	8.0	7	1.0	4.5
FF●	1T	12.0	46.0	35.0	10.0	9	1.3	6.5
FF●	2T	15.0	55.0	43.0	13.0	12	1.3	8.5
FF●	3T	18.8	64.0	49.0	16.0	14	2.6	10.5

M1 Cable assembly (page 129)

FA● Fixed plug, key (G or A to L), non-latching, nut fixing

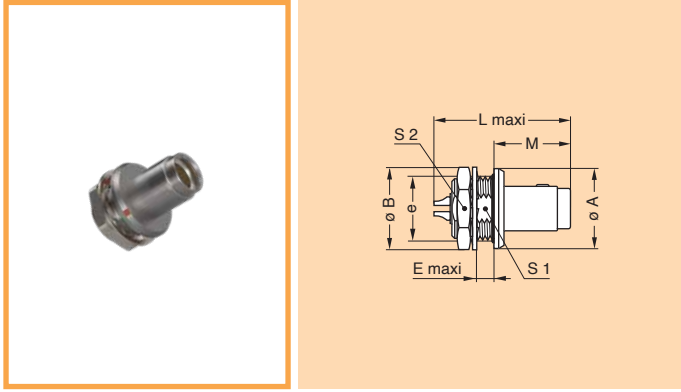

Reference		Dimensions (mm)							
Model	Series	A	B	e	E	L	M	S1	S2
FA●	TT	10.0	10.2	M7x0.5	2.6	17.2	9.2	6.3	9
FA●	0T	12.0	12.5	M9x0.6	3.2	21.5	11.6	8.2	11
FA●	1T	15.5	16.0	M12x1.0	4.0	24.4	12.9	10.5	14
FA●	2T	18.5	19.6	M15x1.0	5.7	28.8	13.9	13.5	17
FA●	3T	23.5	25.1	M18x1.0	5.3	32.3	17.5	16.5	22

P1 Panel cut-out (page 117)

Note: ¹⁾ maximum length with crimp contacts

PH● Free cable socket, key (G or A to L), cable collet and oversize cable collet ¹⁾

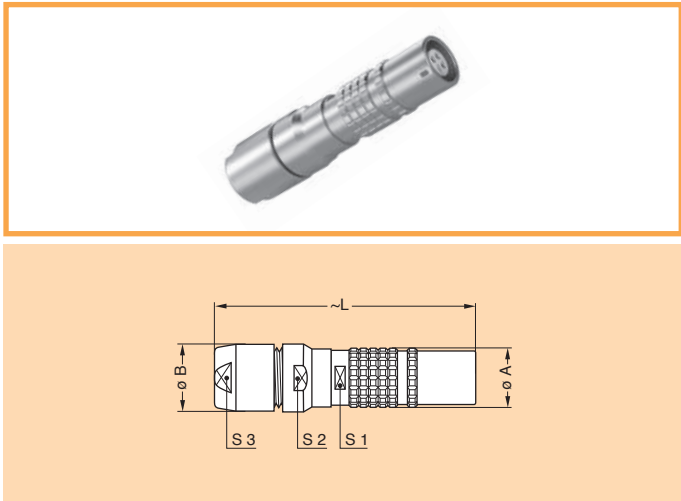

Reference		Dimensions (mm)						Cable ϕ	
Model	Series	A	B	L	S1	S2	S3	min.	max.
PH●	0T	9.5	10.9	49.7	8	10	9	4.6	6.5
PH●	1T	12.0	13.9	58.2	10	13	12	6.6	8.5
PH●	2T	15.0	16.5	66.6	13	15	14	8.6	10.5
PH●	3T	18.8	23.0	85.5	16	20	20	10.6	15.0

M2 Cable assembly (page 129)

Note: ¹⁾ correspond to K type of collet, the fitting of oversize collets onto this model allows them to be fitted to the cables that can be accommodated by the next housing size up (see page 83).

Watertight or vacuumtight models

Watertight models are identified by a letter «P» at the end of the reference. Most of these models are also available in a vacuumtight version. Such models are identified by the letters «PV» at the end of the part number (certificate on request). See page 64 for technical characteristics.

HM● Socket with earthing tag, nut fixing, key (G or A to L), watertight or vacuumtight (back panel mounting)

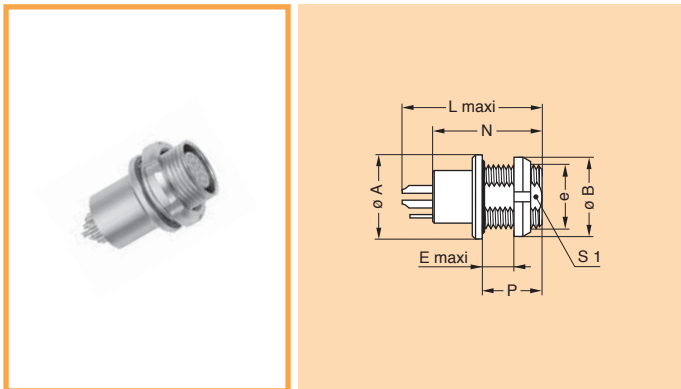

Reference		Dimensions (mm)							
Model	Series	A	B	e	E	L	N	P	S1
HM●	TT	10.0	10.0	M7x0.5	4.5	18.0	15.0	7	6.3
HM●	0T	12.0	12.0	M9x0.6	6.5	22.0	18.5	9	8.2
HM●	1T	15.5	16.0	M12x1.0	6.5	26.0	21.5	10	10.5
HM●	2T	18.5	20.0	M15x1.0	7.5	30.5	25.0	11	13.5

P5 Panel cut-out (page 117)



Plastic housing models

These connectors are particularly recommended for all applications requiring maximum electrical insulation when mated. The design, including a latch sleeve and a metal earthing crown, guarantees EMC screening efficiency to meet most requirements.

Technical characteristics

Mechanical and climatical

Characteristics	Value	Standard
	POM	
Colour	black	–
Endurance ¹⁾	> 3000 cycles	IEC 60512-5 test 9a
Humidity	up to 95% at 60°C	–
Temperature range	- 40°C, + 115°C	–
Sterilization resistance ²⁾	none	IEC 60601-1 § 44.7
Resistance to organic solvents	very good	–

Note: ¹⁾ see page 133, contact resistance after mating cycles. See page 131, mechanical endurance latching force. ²⁾ Steam sterilization.

FG● Straight plug, key (G or A to L), cable collet and nut for fitting a bend relief, POM outer shell ¹⁾

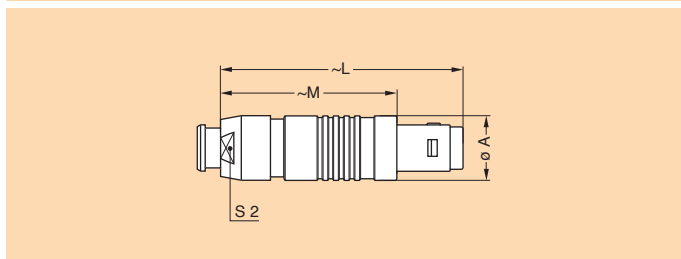

Reference		Dimensions (mm)				Cable ø	
Model	Series	A	L	M	S2	min.	max.
FG●	0T	9.7	38.5	28.5	8	1.0	4.5
FG●	1T	13.0	45.0	34.0	10	1.3	6.5

M1 Cable assembly (page 129)

Note: ¹⁾ to order, add a «Z» at the end of the reference. The bend relief must be ordered separately (see page 105).

EG● Socket, nut fixing, key (G or A to L), POM outer shell

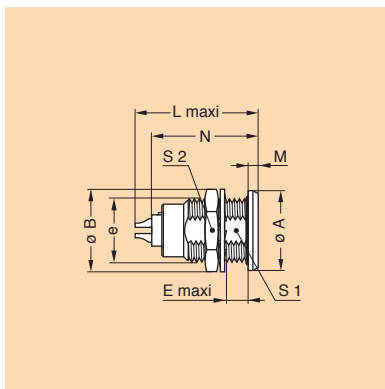

Reference		Dimensions (mm)								
Model	Series	A	B	e	E	L	M	N ¹⁾	S1	S2
EG●	0T	12.0	12.5	M9x0.6	6.0	21.0	1.5	19.1	8.2	11
EG●	1T	15.5	16.0	M12x1.0	6.0	23.0	1.8	21.5	10.5	14

P1 Panel cut-out (page 117)

Note: ¹⁾ maximum length with crimp contacts.



Alignment key

Alignment key and polarized keying system

T series connector model part numbers are composed of three letters. The LAST LETTER indicates the key position and the contact type (male or female).

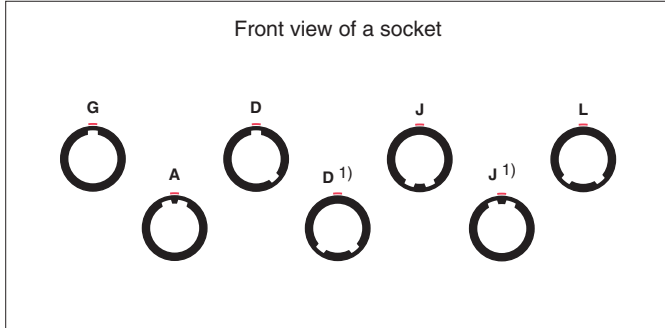

Ref.	Nb of spurs	Contact type	
		Plug	Socket
G	1	male	female
A	2	male	female
D	2	male	female
J	2	female	male
L	2	female	male

● Standard
● Special

Note: ¹⁾ for 2T and 3T series.

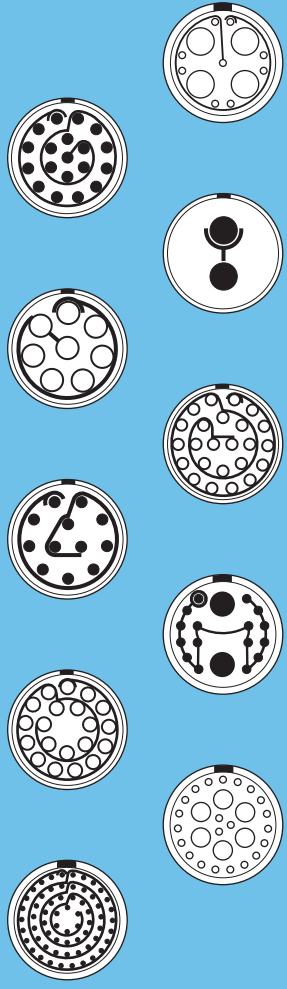

B, K, T SERIES INSERT CONFIGURATION

Multipole insert configuration

Multipole

	Solder contacts		Crimp contacts		Reference	Series	Contact ø (mm)	Contact type				AWG			Solder contact		Crimp contact		Rated current (A) ¹⁾
	Solder	Crimp	Print (straight)	Print (elbow)				Solder (max.)	Crimp		Test voltage (kV DC) ¹⁾ Contact-contact	Test voltage (kV DC) ⁴⁾ Contact-shell	Test voltage (kV DC) ¹⁾ Contact-contact	Test voltage (kV DC) ⁴⁾ Contact-shell					
									min.	max.									
2			302	00-TT	0.5	●	●	●	●	30	32	28	1.40	1.40	1.70	1.70	4.0		
				0B-0K-0T	0.9	●	●	●	●	20	32	20	1.90	1.50	2.00	1.70	10.0 ²⁾		
				1B-1K-1T	1.3	●	●	●	●	20	26	18	2.10	2.00	2.40	2.00	15.0 ³⁾		
				2B-2K-2T	2.0	●	●	●	●	16	18	12	3.00	2.90	4.10	3.80	20.5 ³⁾		
				3B-3K-3T	3.0	●	●	●	—	12	14	10	3.00	2.20	3.20	2.60	35.0		
				5B-5K	6.0	●	—	—	—	8	—	—	6.50	4.90	—	—	60.0		
3			303	00-TT	0.5	●	●	●	●	30	32	28	1.10	1.40	2.00	1.70	3.5		
				0B-0K-0T	0.9	●	●	●	●	20	32	20	1.70	1.30	2.40	2.30	8.0 ²⁾		
				1B-1K-1T	1.3	●	●	●	●	20	26	18	1.90	2.20	2.30	2.60	12.0		
				2B-2K-2T	1.6	●	●	●	●	18	22	14	3.50	2.60	2.70	2.70	17.0 ³⁾		
				3B-3K-3T	2.0	●	●	●	●	16	18	12	2.70	2.10	4.50	3.80	25.0		
4			304	00-TT	0.5	●	●	●	●	30	32	28	1.10	0.90	1.50	1.50	2.5		
				0B-0K-0T	0.7	●	●	●	●	22	32	22	1.20	1.00	2.00	1.60	7.0 ²⁾		
				1B-1K-1T	0.9	●	●	●	●	22	32	20	2.00	2.00	2.40	2.60	10.0 ²⁾		
				2B-2K-2T	1.3	●	●	●	●	20	26	18	2.60	2.60	3.20	3.20	15.0 ³⁾		
				3B-3K-3T	2.0	●	●	●	●	16	18	12	2.00	1.80	3.40	2.50	17.0		
				4B-4K	3.0	●	●	●	—	12	14	10	3.00	2.10	2.60	1.70	30.0		
				5B-5K	4.0	●	●	●	—	10	12	10	4.20	3.80	4.50	3.40	48.0		
5			305	00-TT	0.35	●	—	●	—	30	—	—	1.10	1.40	—	—	1.7		

Note: 1) see calculation method, caution and suggested standard on page 134.
 2) rated current = 6 A for socket with elbow (90°) contact for printed circuit.
 3) rated current = 12 A for socket with elbow (90°) contact for printed circuit.
 4) test voltage (kV) contact-shell is slightly lower for K and T series (values here are for B series).

● Standard
 ● Special

Multipole

	Solder contacts		Reference	Series	Contact ø (mm)	Contact type				AWG			Solder contact		Crimp contact		Rated current (A) ¹⁾
	Crimp contacts					Solder	Crimp	Print (straight)	Print (elbow)	Solder (max.)	Crimp		Test voltage (kV DC) ¹⁾ Contact-contact	Test voltage (kV DC) ⁵⁾ Contact-shell	Test voltage (kV DC) ¹⁾ Contact-contact	Test voltage (kV DC) ⁵⁾ Contact-shell	
											min.	max.					
5			305	0B-0K-0T	0.7	●	●	●	●	22	32	22	1.40	1.00	1.80	1.70	5.0 ²⁾
				1B-1K-1T	0.9	●	●	●	●	22	32	20	1.80	1.70	1.90	2.20	9.0 ²⁾
				2B-2K-2T	1.3	●	●	●	●	20	26	18	2.50	2.30	3.10	3.10	14.0 ³⁾
				3B-3K-3T	1.6	●	●	●	●	18	22	14	2.70	1.80	3.40	2.50	12.5
6			306	0B-0K-0T	0.5	●	● ⁴⁾	●	●	28	32	28	1.20	0.90	2.00	1.70	3.0
				1B-1K-1T	0.7	●	●	●	●	22	32	22	1.50	1.70	2.00	2.00	7.0 ²⁾
6			306	00-TT	0.35	●	-	-	-	30	-	-	0.60	0.80	-	-	1.5
				2B-2K-2T	1.3	●	●	●	●	20	26	18	2.00	2.00	2.90	3.30	12.0
				3B-3K-3T	1.6	●	●	●	●	18	22	14	2.30	1.70	2.70	2.60	11.0
				4B-4K	2.0	●	●	● ⁴⁾	-	16	18	12	2.90	2.50	3.90	3.40	24.0
7			307	0B-0K-0T	0.5	●	● ⁴⁾	●	●	28	32	28	1.10	1.00	2.00	1.90	3.0
				1B-1K-1T	0.7	●	●	●	●	22	32	22	1.40	1.50	2.00	2.00	7.0 ²⁾
				2B-2K-2T	1.3	●	●	●	●	20	26	18	2.50	2.30	2.80	3.10	11.0
				3B-3K-3T	1.6	●	●	●	● ⁴⁾	18	22	14	2.40	1.80	2.90	2.90	11.0
				4B-4K	2.0	●	●	● ⁴⁾	-	16	18	12	2.90	2.60	2.10	2.00	16.0
8			308	1B-1K-1T	0.7	●	●	●	●	22	32	22	1.10	1.00	2.00	1.90	5.0
8			308	2B-2K-2T	0.9	●	●	●	●	22	32	20	2.10	1.80	2.80	2.80	10.0 ²⁾
				3B-3K-3T	1.3	●	●	●	●	20	26	18	2.30	1.70	2.60	2.50	13.0

Note: 1) see calculation method, caution and suggested standard on page 134.
 2) rated current = 4.8 A for socket with elbow (90°) contact for printed circuit.
 3) rated current = 12 A for socket with elbow (90°) contact for printed circuit.
 4) available only for connectors fitted with male contacts.
 5) test voltage (kV) contact-shell is slightly lower for K and T series (values here are for B series).

● Standard
 ● Special

Multipole

	Solder contacts		Crimp contacts		Reference	Series	Contact ø (mm)	Contact type				AWG		Solder contact		Crimp contact		Rated current (A) ¹⁾
	Solder	Crimp	Print (straight)	Print (elbow)				Solder (max.)	Crimp		Test voltage (kV DC) ¹⁾ Contact-contact	Test voltage (kV DC) ⁴⁾ Contact-shell	Test voltage (kV DC) ¹⁾ Contact-contact	Test voltage (kV DC) ⁴⁾ Contact-shell				
									min.	max.								
9			309	0B-0K-0T	0.5	●	● ³⁾	●	●	28	32	28	1.10	1.60	1.70	1.70	2.5	
10			310	1B-1K-1T	0.5	●	● ³⁾	●	●	28	32	28	1.30	2.10	1.90	2.30	2.0	
				2B-2K-2T	0.9	●	●	●	●	22	32	20	2.00	1.90	2.60	3.00	8.0 ²⁾	
				3B-3K-3T	1.3	●	●	●	●	20	26	18	1.80	1.30	2.10	2.60	12.0	
				4B-4K	1.6	●	●	●	—	18	22	14	2.60	1.90	2.70	2.80	17.0	
				5B-5K	3.0	●	●	●	—	12	14	10	3.30	3.20	3.80	4.50	20.0	
12			312	0B-0K-0T	0.35	●	—	●	—	30	—	—	1.10	1.50	—	—	1.7	
12			312	XB	0.7	●	—	●	—	22	32	22	1.40	1.70	—	—	4.0	
12			312	2B-2K-2T	0.7	●	●	●	●	22	32	22	1.80	2.00	2.30	2.90	7.0 ²⁾	
				3B-3K-3T	0.9	●	●	●	●	22	32	20	2.00	1.40	2.30	2.60	9.0	
				4B-4K	1.3	●	●	●	—	20	26	18	2.00	2.30	2.70	2.60	12.0	
14			314	1B-1K-1T	0.5	●	● ³⁾	●	●	28	32	28	1.10	1.70	1.90	2.10	2.0	
				2B-2K-2T	0.7	●	●	●	●	22	32	22	1.70	2.00	2.30	2.90	6.5 ²⁾	
				3B-3K-3T	0.9	●	●	●	●	22	32	20	1.70	1.70	2.60	2.30	9.0 ²⁾	
				5B-5K	2.0	●	●	●	—	16	18	12	3.30	2.90	3.50	4.40	18.0	

Note: 1) see calculation method, caution and suggested standard on page 134.
 2) rated current = 6 A for socket with elbow (90°) contact for printed circuit.
 3) available only for connectors fitted with male contacts.
 4) test voltage (kV) contact-shell is slightly lower for K and T series (values here are for B series).

● Standard
 ● Special

Multipole

	Solder contacts		Reference	Series	Contact ø (mm)	Contact type				AWG			Solder contact		Crimp contact		Rated current (A) ¹⁾
						Solder	Crimp	Print (straight)	Print (elbow)	Solder (max.)	Crimp		Test voltage (kV DC) ¹⁾ Contact-contact	Test voltage (kV DC) ³⁾ Contact-shell	Test voltage (kV DC) ¹⁾ Contact-contact	Test voltage (kV DC) ³⁾ Contact-shell	
											min.	max.					
16			316	1B-1K-1T	0.5	●	● ²⁾	●	●	28	32	28	1.10	1.80	1.40	2.30	2.0
16			316	2B-2K-2T	0.7	●	●	●	●	22	32	22	1.40	1.80	2.20	2.50	6.0
				3B-3K-3T	0.9	●	●	●	●	22	32	20	1.70	1.20	2.60	2.10	8.0
				4B-4K	0.9	●	●	●	—	22	32	20	2.00	2.10	3.20	3.00	10.0
				5B-5K	2.0	●	●	●	—	16	18	12	2.60	2.80	3.50	4.40	12.0
18			318	2B-2K-2T	0.7	●	●	●	●	22	32	22	1.20	1.70	2.00	3.00	5.5
				3B-3K-3T	0.9	●	●	●	●	22	32	20	1.70	1.50	2.60	2.30	7.0
19			319	2B-2K-2T	0.7	●	●	●	●	22	32	22	1.40	1.80	2.20	2.30	5.0
20			320	3B-3K-3T	0.7	●	●	●	●	22	32	22	1.40	1.30	2.00	2.20	6.0
20			320	4B-4K	0.9	●	●	●	—	22	32	20	2.30	3.10	2.70	2.60	8.0
				5B-5K	1.6	●	●	●	—	18	22	14	2.70	2.40	3.20	3.40	10.0

Note: 1) see calculation method, caution and suggested standard on page 134.
 2) available only for connectors fitted with male contacts.
 3) test voltage (kV) contact-shell is slightly lower for K and T series (values here are for B series).

● Standard
 ● Special

Multipole

	Solder contacts		Crimp contacts		Reference	Series	Contact ø (mm)	Contact type				AWG		Solder contact		Crimp contact		Rated current (A) ¹⁾			
	Solder	Crimp	Print (straight)	Print (elbow)				Solder (max.)	Crimp		Test voltage (kV DC) ¹⁾ Contact-contact	Test voltage (kV DC) ²⁾ Contact-shell	Test voltage (kV DC) ¹⁾ Contact-contact	Test voltage (kV DC) ²⁾ Contact-shell							
									min.	max.											
22					322	XB	0.5	●	-	●	-	28	-	-	0.80	1.40	-	-	1.5		
22					322	3B-3K-3T	0.7	●	●	●	●	22	32	22	1.40	1.30	2.40	2.00	5.5		
24					324	3B-3K-3T	0.7	●	●	●	●	22	32	22	1.40	1.10	2.00	2.00	4.0		
								4B-4K	0.9	●	●	●	-	22	32	20	1.70	2.00	2.60	2.90	7.0
										5B-5K	1.6	●	●	-	-	18	22	14	1.90	2.20	2.70
26					326	2B-2K-2T	0.5	●	-			●	●	28	-	-	1.00	1.90	-	-	1.5
								3B-3K-3T	0.7	●	●	●	●	22	32	22	1.40	1.00	2.10	1.90	3.5
30					330	3B-3K-3T	0.7			●	●	●	●	22	32	22	1.10	1.00	2.00	1.70	3.5
								4B-4K	0.9	●	●	●	-	22	32	20	1.40	1.20	2.50	2.00	5.0
										5B-5K	1.3	●	●	●	-	20	26	18	2.00	2.30	2.90
32					332	2B-2K-2T	0.5	●	-			●	●	28	-	-	1.10	2.00	-	-	1.3

Note: 1) see calculation method, caution and suggested standard on page 134.
 2) test voltage (kV) contact-shell is slightly lower for K and T series (values here are for B series).

● Standard
 ● Special



Multipole

	Solder contacts		Reference	Series	Contact ø (mm)	Contact type				AWG			Solder contact		Crimp contact		Rated current (A) ¹⁾
						Solder	Crimp	Print (straight)	Print (elbow)	Solder (max.)	Crimp		Test voltage (kV DC) ¹⁾ Contact-contact	Test voltage (kV DC) ²⁾ Contact-shell	Test voltage (kV DC) ¹⁾ Contact-contact	Test voltage (kV DC) ²⁾ Contact-shell	
											min.	max.					
32			332	3B-3K-3T	0.7	●	●	●	●	22	32	22	1.10	1.40	-	-	3.0
40			340	4B-4K	0.7	●	●	●	-	22	32	22	1.40	1.40	2.00	1.90	3.0
					5B-5K	1.3	●	●	●	-	20	26	18	1.90	2.00	2.90	2.80
48			348	4B-4K	0.7	●	●	●	-	22	32	22	1.10	1.10	1.10	2.10	3.0
					5B-5K	1.3	●	●	●	-	20	26	18	1.70	1.60	2.90	2.20
50			350	5B-5K	0.9	●	●	●	-	22	32	20	1.90	2.30	2.30	2.40	3.5
54			354	5B-5K	0.9	●	●	●	-	22	32	20	1.70	2.20	2.90	3.00	3.5
64			364	5B-5K	0.9	●	●	●	-	22	32	20	1.90	2.20	2.40	2.00	3.0

Note: ¹⁾ see calculation method, caution and suggested standard on page 134.

²⁾ test voltage (kV) contact-shell is slightly lower for K and T series (values here are for B series).

● Standard
● Special

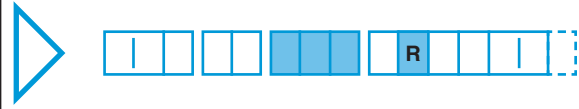

Mixed insert configuration

Mixed multipole

	Male insert	Female insert	Reference	Number of contacts	ø contact (mm)	Solder contact	AWG	Test voltage (kV DC) ¹⁾ Contact-contact	Test voltage (kV DC) ¹⁾ Contact-shell	Rated current (A) ²⁾	
0B 0K 0T			307³⁾	5	0.5	●	28-30-32 22-24-26	1.1	1.0	0.5 8.0	
				2	0.7						
3B 3K 3T			306	4	0.9	●	20-22-24 10-12-14	2.9 3.0	1.8	8.5 41.5	
			308	2	0.9						3.0
			312	10	0.7						3.0
			318	2	0.7						3.0
4B 4K			313	9	0.7	●	22-24-26 10-12-14	2.0 3.3	1.8	6.5 35.5	
			314	12	0.9						3.0
			315	12	0.7						3.0
			318	16	0.9						3.0
			320	18	0.7						3.0
			324	18	0.7						1.6
			328	22	0.7						1.6

Note:

- 1) test voltage according to IEC 60512-4-1 test 4a. Altitude correction factor is given in IEC 60664-1 table A.2.
- 2) the specified rated current can be applied simultaneously to all the contacts. It corresponds to an average temperature rise of 40°C of the connector (measured according to IEC 60512-5-1 test 5a).
- 3) configuration not available with keying F for 0B series.

- Standard
- Special

Housings (B, K and T series)

Ref.	Outer shell and collet nut		Latch sleeve + earthing crown		Other metallic components		Remarks
	Material	Surf. treatment	Material	Surf. treatment	Material	Surf. treatment	
C	Brass	chrome	brass/bronze	nickel ²⁾	brass	nickel	
N	Brass	nickel	brass/bronze	nickel ²⁾	brass	nickel	
K	Brass	black chrome ³⁾	brass/bronze	nickel ²⁾	brass	nickel	
S	Stainless steel	–	brass/bronze	nickel ²⁾	brass	nickel	
T	Stainless steel	–	stainless steel	–	brass	nickel	
U	Stainless steel	–	stainless steel	–	stainless steel	–	
L	Aluminium alloy	anodized	brass/bronze	nickel ²⁾	brass	nickel	¹⁾
X	Aluminium alloy	nickel anthracite	brass/bronze	nickel ²⁾	brass	nickel	
G	PEEK (natural)	–	brass/bronze	nickel ²⁾	brass	nickel	Only for FGG and ENG (B series)
P	PSU	–	brass/bronze	nickel ²⁾	brass	nickel	Only for FGY and ENY (B series) ¹⁾
R	PPSU	–	brass/bronze	nickel ²⁾	brass	nickel	Only for FGY and ENY (B series) ¹⁾
H	PPS/brass	–/nickel	brass/bronze	nickel ²⁾	brass	nickel	Only for elbow sockets (B series)
P	PA.6	–	brass/bronze	nickel ²⁾	brass	nickel	Only for CRF and CRG bridge plug ¹⁾
B	POM (black)	–	brass/bronze	nickel ²⁾	brass	nickel	Only for FGG and EGG T series

Note: detailed characteristics of these materials and treatments are presented on page 130.

¹⁾ see «variant» for the colour.

²⁾ in the K series, the latch sleeve is chrome-plated.

³⁾ surface not conductive use socket with earthing tag (EN● and HM● model) to carry shield.

- Standard
- Special

Insulators (B, K and T series)

Ref.	Material	Contact type	Remarks
Y	PEEK	Crimp	extended design, with contacts that recess into insulator
L	PEEK	Solder or print	
R	PEEK	Solder, crimp or print	mixed multipole

Contacts (B, K and T series)

Soldering characteristics

- no need to order specific tools, a simple soldering iron is sufficient
- ideal for very small and fragile conductors
- contacts with solder cups to allow the solder to flow

Crimping characteristics

- practical, quick contact fixing outside the insulator
- possible use at high temperature
- need to order specific tools
- no risk of heating the insulator during the conductor-contact fixing
- high tensile strength
- totally lead-free solution

Contacts reference for couplers R●● and S●●

Ref.	Contact type	Remarks
A	Male - Female	contact configuration is explained on page 21, 24, 55
L	Female - Male	contact configuration is explained on page 21, 24, 55
M	Female - Female	contact configuration is explained on page 21

Contacts reference for plugs, sockets and free or fixed cable sockets

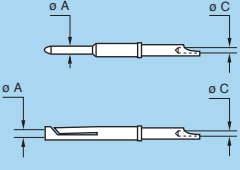
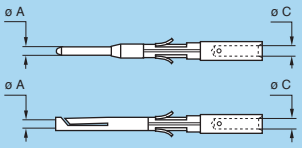
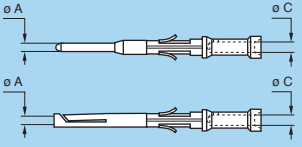
Contact type	Reference		Contact			Conductor				F _r ¹⁾ (N)		
	Male	Female	ø A (mm)	ø C (mm)	Form per fig.	Solid		Stranded				
						AWG max.	Section max. (mm ²)	AWG			Section (mm ²)	
								min.	max.	min.	max.	
Solder 	A	L	0.35	0.40	–	28	0.09	–	30	–	0.05	–
			0.5 ²⁾	0.40 ²⁾	–	28	0.09	–	30	–	0.05	–
			0.5	0.45 ⁶⁾	–	28	0.09	–	28	–	0.09	–
			0.7	0.80	–	22	0.34	–	22 ³⁾	–	0.34	–
			0.9	0.80 ⁵⁾	–	22 ⁵⁾	0.34 ⁵⁾	–	22 ³⁾⁵⁾	–	0.34 ⁵⁾	–
			1.3	1.00	–	20	0.50	–	20 ³⁾	–	0.50	–
			1.6	1.40	–	16	1.00	–	18	–	1.00	–
			2.0	1.80	–	14	1.50	–	16	–	1.50	–
			3.0	2.70	–	10	4.00	–	12	–	4.00	–
			4.0	3.70	–	10	6.00	–	10	–	6.00	–
6.0	5.20	–	–	–	–	–	–	8	–	10.00	–	
Crimp fig. 1  fig. 2 	C	M	0.5 ⁴⁾	0.45	1	–	–	32	28	0.035	0.09	12
	C	M	0.7	0.80	1	–	–	26	22 ³⁾	0.140	0.34	22
	B	P	0.7	0.45	2	–	–	32	28	0.035	0.09	22
	C	M	0.9	1.10	1	–	–	24	20	0.250	0.50	30
	B	P	0.9	0.80	2	–	–	26	22 ³⁾	0.140	0.34	30
	G	U	0.9	0.45	2	–	–	32	28	0.035	0.09	30
	C	M	1.3	1.40	1	–	–	20	18	0.500	1.00	40
	B	P	1.3	1.10	2	–	–	24	20	0.250	0.50	40
	G	U	1.3	0.80	2	–	–	26	22 ³⁾	0.140	0.34	40
	C	M	1.6	1.90	1	–	–	18	14 ³⁾	1.000	1.50	50
	B	P	1.6	1.40	2	–	–	22	18	0.340	1.00	50
	C	M	2.0	2.40	1	–	–	16	12 ³⁾	1.500	2.50	65
	B	P	2.0	1.90	2	–	–	18	14	1.000	1.50	65
	C	M	3.0	3.20	1	–	–	14	10 ³⁾	2.500	4.00	75
	C	M	4.0	4.00	1	–	–	12	10	4.000	6.00	90

Note:

- 1) contact retention force in the insulator (according to IEC 60512-8 test 15 a).
- 2) for 00/TT multipole series.
- 3) for a given AWG, the diameter of some stranded conductor designs is larger than the solder cup diameter. Make sure that the maximum conductor diameter is smaller than ø C.
- 4) for 00 /TT multipole series or for 0B/0T and 1B/1T series with male contacts.
- 5) for 0B.302/0B.303, 0K.302/0K.303 and 0T.302/0T.303 ø C = 1.0 mm, AWG max 20, section max (mm²) 0.50.
- 6) for 00/TT and 1B/1K/1T series, according to manufacturing and plating tolerance ø C min = 0.43 mm.

● Standard ● Special

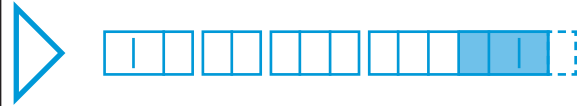

Collets (B, K and T series)

D and M type collets for B series

D type



M type



	Reference		Collet ø		Cable ø		Notes
	Type	Code	ø A	ø B	max.	min.	
00	D	22	2.2	–	2.2	1.4	
	D	27	2.7	–	2.7	> 2.2	
	D	35	3.5	2.8	3.5	> 2.7	8) 9)
0B	D	22	2.1	–	2.2	1.4	2)
	D	32	3.2	–	3.2	> 2.2	
	D	42	4.2	–	4.2	> 3.2	
	D	52	5.2	4.7	5.2	> 4.2	8) 9)
	D	56	5.6	4.7	5.6	> 5.2	1) 8) 9)
1B	M	27	2.7	–	2.7	> 2.2	
	M	31	3.1	–	3.1	> 2.7	
	D	42	4.2	–	4.2	3.1	
	D	52	5.2	–	5.2	> 4.2	
	D	62	6.2	–	6.2	> 5.2	9)
	D	72	7.2	6.2	7.2	> 6.2	8) 9)
	D	76	7.6	6.9	7.6	> 7.2	1) 8) 9)
XB	D	52	5.2	7.2	5.0	4.4	
	D	62	6.2	7.2	6.0	5.4	
	D	72	7.2	7.2	7.0	6.4	
	D	82	8.2	7.2	8.0	7.4	1)
2B	M	21	2.1	–	2.2	1.4	3)
	M	32	3.1	–	3.2	> 2.2	3)
	D	42	4.2	–	4.2	> 3.2	
	D	52	5.2	–	5.2	> 4.2	
	D	62	6.2	–	6.2	> 5.2	
	D	72	7.2	–	7.2	> 6.2	
	D	82	8.2	–	8.2	> 7.2	9)
	D	92	9.2	8.6	9.2	> 8.2	8) 9)
	D	99	9.9	8.6	9.9	> 9.2	1) 8) 9)

	Reference		Collet ø		Cable ø		Notes
	Type	Code	ø A	ø B	max.	min.	
3B	M	52	5.2	–	5.2	> 4.2	4)
	D	62	6.2	–	6.2	4.9	
	D	72	7.7	–	7.7	> 6.2	
	D	92	9.2	–	9.2	> 7.7	10)
	D	10	10.2	–	10.0	> 9.2	10)
	D	11	11.0	–	11.0	> 10.0	10)
4B	D	12	12.0	10.2	12.0	> 11.0	1) 8) 10)
	M	62	6.2	–	6.2	> 5.2	5)
	M	72	7.2	–	7.2	> 6.2	5)
	M	82	8.2	–	8.2	> 7.2	5)
	M	92	9.2	8.6	9.2	> 8.2	6)
	D	10	10.8	–	10.5	9.1	
	D	12	12.3	–	12.0	10.6	
	D	13	13.8	12.5	13.5	12.1	10)
	D	15	15.3	12.5	15.0	13.6	7) 10)
	D	16	16.3	12.5	16.0	15.1	1) 10)
	5B	D	11	11.8	–	11.5	9.6
D		13	13.8	–	13.5	11.6	
D		15	15.8	–	15.5	13.6	7)
D		17	17.8	–	17.5	15.6	1)
D		19	19.8	–	19.5	17.6	1)
D		21	21.8	–	21.5	19.6	1) 10)
D		23	23.8	21.8	23.5	21.6	1) 10)
D		25	25.3	21.8	25.0	23.6	1) 10)

● Standard ● Special

Note: all dimensions are in millimetres.

- 1) these collets cannot be used for connector models with nut for fitting a bend relief. No bend relief available for this cable size.
- 2) the inner diameter of the smallest bend relief available is 2.5 mm (in TPU) / 1.7 mm (in silicone).
- 3) for 0B bend relief.
- 4) for 1B bend relief.
- 5) for 2B bend relief.
- 6) for 4B bend relief.
- 7) the inner diameter of the largest bend relief available is 14.5 mm.
- 8) for FSG model, standard cable diameter reduced as follow: 0B series (D52) = 4.7 mm, 2B series (D92) = 8.6 mm. For larger diameter use a "K" type collet, please check online Part Search for additional details.
- 9) maximum internal cable bundle diameter for FPG models: 00 = 2.9 mm, 0B = 4.4 mm, 1B = 5.4 mm, 2B = 7.4 mm.
- 10) maximum internal cable bundle diameter for FHG models: 3B = 8.5 mm, 4B = 12 mm, 5B = 20 mm.

C and K type collets for K series

C type

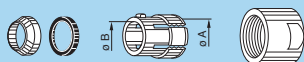

K type

oversize cable collet



	Reference		Collet ø		Cable ø		Notes	
	Type	Code	ø A	ø B	max.	min.		
0K	C	10	1.6	–	1.2	1.0	1)	
	C	15	1.6	–	1.5	1.3	1)	
	C	20	2.1	–	2.0	1.6	1)	
	C	25	3.1	–	2.5	2.1		
	C	30	3.1	–	3.0	2.6		
	C	35	4.2	4.2	3.5	3.1		
	C	40	4.2	4.2	4.0	3.6		
	C	45	5.2	5.2	4.5	4.1		
	C	50	5.2	5.2	5.0	4.6		
	1K	C	15	1.6	–	1.5	1.3	
C		20	2.2	–	2.0	1.6		
C		25	3.2	–	2.5	2.1		
C		30	3.2	–	3.0	2.6		
C		35	4.2	–	3.5	3.1		
C		40	4.2	–	4.0	3.6		
C		45	5.2	–	4.5	4.1		
C		50	5.2	–	5.0	4.6		
C		55	6.2	6.2	5.5	5.1		
C		60	6.2	6.2	6.0	5.6		
C		65	7.2	6.7	6.5	6.1		
K		70	7.2	–	7.0	6.6	3)	
K		75	8.2	8.2	7.5	7.1	3)	
K		80	8.2	8.2	8.0	7.6	3)	
K		85	9.2	8.6	8.5	8.1	3)	
2K		C	15	2.2	–	1.5	1.3	
		C	20	2.2	–	2.0	1.6	
		C	25	3.2	–	2.5	2.1	
	C	30	3.2	–	3.0	2.6		
	C	35	4.2	–	3.5	3.1		
	C	40	4.2	–	4.0	3.6		
	C	45	5.2	–	4.5	4.1		
	C	50	5.2	–	5.0	4.6		
	C	55	6.2	–	5.5	5.1		
	C	60	6.2	–	6.0	5.6		
	C	65	7.2	–	6.5	6.1		
	3K	C	30	3.2	–	3.0	2.6	
		C	35	4.2	–	3.5	3.1	
		C	40	4.2	–	4.0	3.6	
		C	45	5.2	–	4.5	4.1	
C		50	5.2	–	5.0	4.6		
C		55	6.2	–	5.5	5.1		
C		60	6.2	–	6.0	5.6		
C		65	7.2	–	6.5	6.1		
C		70	7.2	–	7.0	6.6		
C		75	8.2	–	7.5	7.1		

	Reference		Collet ø		Cable ø		Notes	
	Type	Code	ø A	ø B	max.	min.		
2K	C	70	7.2	–	7.0	6.6		
	C	75	8.2	8.2	7.5	7.1		
	C	80	8.2	8.2	8.0	7.6		
	C	85	9.2	8.6	8.5	8.1		
	K	90	9.2	–	9.0	8.6	4)	
	K	95	10.2	10.2	9.5	9.1	4)	
	K	10	10.2	10.2	10.0	9.6	4)	
	K	11	11.2	10.6	10.5	10.1	4)	
	3K	C	30	3.2	–	3.0	2.6	
		C	35	4.2	–	3.5	3.1	
		C	40	4.2	–	4.0	3.6	
		C	45	5.2	–	4.5	4.1	
		C	50	5.2	–	5.0	4.6	
		C	55	6.2	–	5.5	5.1	
		C	60	6.2	–	6.0	5.6	
C		65	7.2	–	6.5	6.1		
C		70	7.2	–	7.0	6.6		
C		75	8.2	–	7.5	7.1		
C		80	8.2	–	8.0	7.6		
C		85	9.2	–	8.5	8.1		
C		90	9.2	–	9.0	8.6		
C		95	10.2	10.2	9.5	9.1		
C		10	10.2	10.2	10.0	9.6		
C	11	11.2	10.6	10.5	10.1			
K	11	12.3	–	12.0	10.6	5)		
K	12	13.8	13.8	12.8	12.1	5)		
K	13	13.8	13.8	13.5	12.9	5)		
K	14	15.3	15.3	14.0	13.6	5)		
K	15	15.3	15.3	15.0	14.1	2)		

● Standard ● Special

Note: all dimensions are in millimetres.

1) the inner diameter of the smallest bend relief available is 2.5 mm (in TPU) / 1.7 mm (in silicone).

2) the inner diameter of the largest bend relief available is 14.5 mm.

3) for 2B bend relief.

4) for 3B bend relief.

5) for 4B bend relief.

C and K type collets for K series

C type

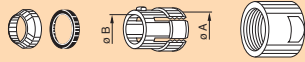

C type (5K series)

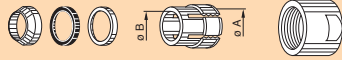

K type

oversize cable collet

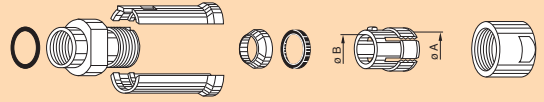

	Reference		Collet ø		Cable ø		Notes
	Type	Code	ø A	ø B	max.	min.	
4K	C	50	6.3	–	5.0	4.8	
	C	55	6.3	–	5.5	5.1	
	C	60	6.3	–	6.0	5.6	
	C	65	7.3	–	6.5	6.1	
	C	70	7.3	–	7.0	6.6	
	C	75	8.3	–	7.5	7.1	
	C	80	8.3	–	8.0	7.6	
	C	85	9.3	–	8.5	8.1	
	C	90	9.3	–	9.0	8.6	
	C	95	10.8	–	9.5	9.1	
	C	10	10.8	–	10.5	9.6	
	C	11	12.3	–	12.0	10.6	
	C	12	13.8	13.8	12.8	12.1	
	C	13	13.8	13.8	13.5	12.9	
	C	14	15.3	15.3	14.0	13.6	
	C	15	15.3	15.3	15.0	14.1	2)
	K	16	17.8	–	16.5	15.6	1)
	K	17	17.8	–	17.5	16.6	1)
	K	18	19.8	–	18.5	17.6	1)
	K	19	19.8	–	19.5	18.6	1)
	K	20	21.8	–	20.5	19.6	1)
	K	21	21.8	–	21.5	20.6	1)
	K	22	23.8	23.8	22.5	21.6	1)
K	23	23.8	23.8	23.5	22.6	1)	

	Reference		Collet ø		Cable ø		Notes
	Type	Code	ø A	ø B	max.	min.	
5K	C	10	11.8	–	10.5	9.6	
	C	11	11.8	–	11.5	10.6	
	C	12	13.8	–	12.5	11.6	
	C	13	13.8	–	13.5	12.6	
	C	14	15.8	–	14.5	13.6	
	C	15	15.8	–	15.5	14.6	1)
	C	16	17.8	–	16.5	15.6	1)
	C	17	17.8	–	17.5	16.6	1)
	C	18	19.8	–	18.5	17.6	1)
	C	19	19.8	–	19.5	18.6	1)
	C	20	21.8	–	20.5	19.6	1)
	C	21	21.8	–	21.5	20.6	1)
	C	22	23.8	23.8	22.5	21.6	1)
	C	23	23.8	23.8	23.5	22.6	1)

● Special

Note: all dimensions are in millimetres.

1) these collets cannot be used for connector models with nut for fitting a bend relief. No bend relief available for this cable size.

2) the inner diameter of the largest bend relief available is 14.5 mm.

C and K type collets for T series

C type

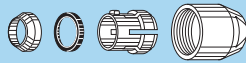

K type

oversize
cable collet

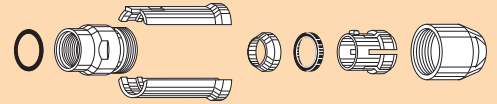

	Type	Cable ø (mm)		Note
		min.	max.	
TT	C27	2.4	2.6	
	C31	2.7	3.0	
OT	C10	1.0	1.2	1)
	C15	1.3	1.5	1)
	C20	1.6	2.0	1)
	C25	2.1	2.5	
	C30	2.6	3.0	
	C35	3.1	3.5	
	C40	3.6	4.0	
	C45	4.1	4.5	
	K50	4.6	5.0	2)
	K55	5.1	5.5	2)
1T	C15	1.3	1.5	
	C20	1.6	2.0	
	C25	2.1	2.5	
	C30	2.6	3.0	
	C35	3.1	3.5	
	C40	3.6	4.0	
	C45	4.1	4.5	
	C50	4.6	5.0	
	C55	5.1	5.5	
	C60	5.6	6.0	
C65	6.1	6.5		
K70	6.6	7.0	3)	
K75	7.1	7.5	3)	
K80	7.6	8.0	3)	
K85	8.1	8.5	3)	

	Type	Cable ø (mm)		Note
		min.	max.	
2T	C15	1.3	1.5	
	C20	1.6	2.0	
	C25	2.1	2.5	
	C30	2.6	3.0	
	C35	3.1	3.5	
	C40	3.6	4.0	
	C45	4.1	4.5	
	C50	4.6	5.0	
	C55	5.1	5.5	
	C60	5.6	6.0	
	C65	6.1	6.5	
	C70	6.6	7.0	
	C75	7.1	7.5	
	C80	7.6	8.0	
	C85	8.1	8.5	
	K90	8.6	9.0	4)
K95	9.1	9.5	4)	
K10	9.6	10.0	4)	
K11	10.1	10.5	4)	

	Type	Cable ø (mm)		Note
		min.	max.	
3T	C30	2.6	3.0	
	C35	3.1	3.5	
	C40	3.6	4.0	
	C45	4.1	4.5	
	C50	4.6	5.0	
	C55	5.1	5.5	
	C60	5.6	6.0	
	C65	6.1	6.5	
	C70	6.6	7.0	
	C75	7.1	7.5	
	C80	7.6	8.0	
	C85	8.1	8.5	
	C90	8.6	9.0	
	C95	9.1	9.5	
	C10	9.6	10.0	
C11	10.1	10.5		
K11	10.6	12.0		
K12	12.1	12.8		
K13	12.9	13.5		
K14	13.6	14.0		
K15	14.1	15.0	5)	

● Standard ● Special

Note: all dimensions are in millimetres.

1) the inner diameter of the smallest bend relief available is 2.5 mm (in TPU) / 1.7 mm (in silicone).

2) for 1B bend relief.

3) for 2B bend relief.

4) for 3B bend relief.

5) the inner diameter of the largest bend relief available is 14.5 mm.

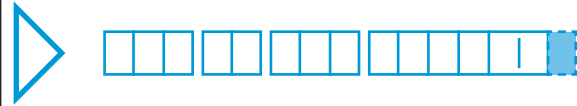

Variant (B, K and T series)

Bend relief for B series models with collet

	Ref.	Collet		Need to be ordered separately (see pages 105 and 106)
		Type	Code	
00	z	D	22 to 35	GMA.00. GMB.00.
0B	z	D	22 to 52	GMA.0B.
1B	z	M	27 and 31	GMA.1B.
		D	42 to 72	GMA.1B.
XB	z	D	52 to 72	GMA.1B.
2B	z	M	21 and 32	GMA.0B.
		D	42 to 92	GMA.2B.
3B	z	M	52	GMA.1B.
		D	62 to 10	GMA.3B.
4B	z	M	62 to 82	GMA.2B.
		M	92	GMA.4B.
		D	10 to 15 ¹⁾	GMA.4B.
5B	z	D	11 to 15 ¹⁾	GMA.4B.

Bend relief for K series models with collet

	Ref.	Collet		Need to be ordered separately (see pages 105 and 106)
		Type	Code	
0K	z	C	10 to 50	GMA.0B.
1K	z	C	15 to 65	GMA.1B.
		K	70 to 85	GMA.2B.
2K	z	C	15 to 85	GMA.2B.
		K	90 to 10	GMA.3B.
3K	z	C	30 to 10	GMA.3B.
		K	11 to 15 ²⁾	GMA.4B.
4K	z	C	50 to 15 ³⁾	GMA.4B.
5K	z	C	10 to 14	GMA.4B.

● Standard ● Special

Note: all dimensions are in millimetres.
¹⁾ for D15 see page 80.
²⁾ for K15 see page 81.
³⁾ for C15 see page 82.

Bend relief for T series models with collet

	Ref.	Collet		Need to be ordered separately (see pages 105 and 106)
		Type	Code	
TT	z	C	27 and 31	GMB.00.
0T	z	C	10 to 45	GMA.0B.
		K	50 to 65	GMA.1B.
1T	z	C	15 to 65	GMA.1B.
		K	70 to 85	GMA.2B.

	Ref.	Collet		Need to be ordered separately (see pages 105 and 106)
		Type	Code	
2T	z	C	15 to 85	GMA.2B.
		K	90 to 10	GMA.3B.
3T	z	C	30 to 10	GMA.3B.
		K	11 to 15 ⁴⁾	GMA.4B.

● Standard ● Special

Note: all dimensions are in millimetres.
⁴⁾ for K15 see page 83.

Colour of the bridge plug shells and connectors shell made of plastic material and aluminium alloys

Ref.	Colour	Bridge plug and plastic shell			Aluminium alloys	
		PSU	PPSU	PA.6	Anodized colour	Anodized colour for bend relief collet nut
A	blue			●	●	
G	grey	●		●		
J	yellow			●	●	
M	brown			●		
N	black			●	●	
R	red			●	●	
S	orange			●		
T	natural				●	
V	green			●	●	
L	black					●
X	natural					●
F	cream		●			

● Special

Note: other anodizing colours are available for connectors with collet nut for bend relief. Please consult us.

Watertight and vacuumtight socket and coupler models (B, K and T series) (not connected)

	Reference		Model
	Watertight	Vacuumtight	
B	P	PV	YH●, HG●, HN●, HH●, HC●, HE●, HM●, S●●
K	P	PV	HG●, HE●, HM●, S●●
T	P	PV	HG●, HE●, HM●

O-ring and gasket material (K and T series)

Standard connectors are delivered with silicone o-ring and gaskets. The vacuumtight models, identified with the letters «PV», are delivered with gaskets.

Ref.	O-ring material
H	FPM
E	EPDM
D	FPM and collet nut for bend relief

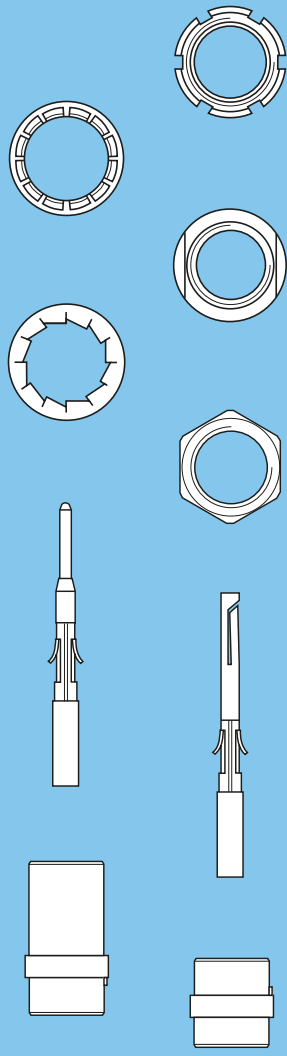

SPARE PARTS

Spare parts for crimp contacts

	Types	Insulator part number		ø (mm)		F.Ø.	Cond. AWG		Contact part number		
		Male contact	Female contact	A	C		min.	max.	Male	Female	
00 TT	302/303/304	FGG.00.30●.YL	EGG.00.40●.YL	0.5	0.45	1	32	28	FGG.00.554.ZZC	EGG.00.654.ZZM	
0B OK OT	302/303	FGG.0B.30●.YL	EGG.0B.40●.YL	0.9		1.10	1	24	20	FGG.0B.560.ZZC	EGG.0B.660.ZZM
						0.80	2	26	22	FGG.0B.561.ZZC	EGG.0B.661.ZZM
						0.45	2	32	28	FGG.0B.562.ZZC	EGG.0B.662.ZZM
	304/305	FGG.0B.30●.YL	EGG.0B.40●.YL	0.7		0.80	1	26	22	FGG.0B.555.ZZC	EGG.0B.655.ZZM
					0.45	2	32	28	FGG.0B.556.ZZC	EGG.0B.656.ZZM	
	306/307/309	FGG.0B.30●.YL	–	0.5	0.45	1	32	28	FGG.0B.554.ZZC	–	
1B 1K 1T	302/303	FGG.1B.30●.YL	EGG.1B.40●.YL	1.3		1.40	1	20	18	FGG.1B.565.ZZC	EGG.1B.665.ZZM
						1.10	2	24	20	FGG.1B.566.ZZC	EGG.1B.666.ZZM
						0.80	2	26	22	FGG.1B.567.ZZC	EGG.1B.667.ZZM
	304/305	FGG.1B.30●.YL	EGG.1B.40●.YL	0.9		1.10	1	24	20	FGG.1B.560.ZZC	EGG.1B.660.ZZM
0.80						2	26	22	FGG.1B.561.ZZC	EGG.1B.661.ZZM	
0.45						2	32	28	FGG.1B.562.ZZC	EGG.1B.662.ZZM	
306/307/308	FGG.1B.30●.YL	EGG.1B.40●.YL	0.7		0.80	1	26	22	FGG.1B.555.ZZC	EGG.1B.655.ZZM	
					0.45	2	32	28	FGG.1B.556.ZZC	EGG.1B.656.ZZM	
	310/314/316	FGG.1B.3●●.YL	–	0.5	0.45	1	32	28	FGG.1B.554.ZZC	–	
2B 2K 2T	302	FGG.2B.302.YL	EGG.2B.402.YL	2.0		2.40	1	16	12	FGG.2B.575.ZZC	EGG.2B.675.ZZM
						1.90	2	18	14	FGG.2B.576.ZZC	EGG.2B.676.ZZM
	303	FGG.2B.303.YL	EGG.2B.403.YL	1.6		1.90	1	18	14	FGG.2B.570.ZZC	EGG.2B.670.ZZM
						1.40	2	22	18	FGG.2B.571.ZZC	EGG.2B.671.ZZM
	304/305 306/307	FGG.2B.30●.YL	EGG.2B.40●.YL	1.3		1.40	1	20	18	FGG.2B.565.ZZC	EGG.2B.665.ZZM
						1.10	2	24	20	FGG.2B.566.ZZC	EGG.2B.666.ZZM
						0.80	2	26	22	FGG.2B.567.ZZC	EGG.2B.667.ZZM
	308/310	FGG.2B.3●●.YL	EGG.2B.4●●.YL	0.9		1.10	1	24	20	FGG.2B.560.ZZC	EGG.2B.660.ZZM
						0.80	2	26	22	FGG.2B.561.ZZC	EGG.2B.661.ZZM
						0.45	2	32	28	FGG.2B.562.ZZC	EGG.2B.662.ZZM
312/314/316 318/319	FGG.2B.3●●.YL	EGG.2B.4●●.YL	0.7		0.80	1	26	22	FGG.2B.555.ZZC	EGG.2B.655.ZZM	
					0.45	2	32	28	FGG.2B.556.ZZC	EGG.2B.656.ZZM	

● Standard ● Special

Tools for crimp contacts

	Types	Positioners part number ¹⁾		Extractors part number for male/female contacts
		Male contact	Female contact	
00 TT	302/303/304	DCE.91.050.0VC	DCE.91.050.0VM	DCC.05.02B.LAG
0B OK OT	302/303	DCE.91.090.BVC	DCE.91.090.BVM	DCC.09.05B.LAG
		DCE.91.090.AVC	DCE.91.090.AVM	
	304/305	DCE.91.070.BVC	DCE.91.070.BVM	DCC.07.04B.LAG
	306/307/309	DCE.91.050.BVC	DCE.91.050.BVM	DCC.05.02B.LAG
1B 1K 1T	302/303	DCE.91.131.BVC	DCE.91.131.BVM	DCC.13.15B.LAG
	304/305	DCE.91.091.BVC	DCE.91.091.BVM	DCC.09.05B.LAG
	306/307/308	DCE.91.071.BVC	DCE.91.071.BVM	DCC.07.04B.LAG
	310/314/316	DCE.91.051.BVC	DCE.91.051.BVM	DCC.05.02B.LAG
2B 2K 2T	302	DCE.91.202.BVCM		DCC.20.25B.LAG
	303	DCE.91.162.BVCM		DCC.16.25B.LAG
	304/305 306/307	DCE.91.132.BVC	DCE.91.132.BVM	DCC.13.15B.LAG
		DCE.91.132.CVC	DCE.91.132.CVM	
	308/310	DCE.91.092.BVC	DCE.91.092.BVM	DCC.09.05B.LAG
DCE.91.092.AVC		DCE.91.092.AVM		
312/314/316 318/319	DCE.91.072.BVC	DCE.91.072.BVM	DCC.07.04B.LAG	

Note: ¹⁾ please consult page 92 for the corresponding crimping tools.

FGG-EGG Crimp contacts

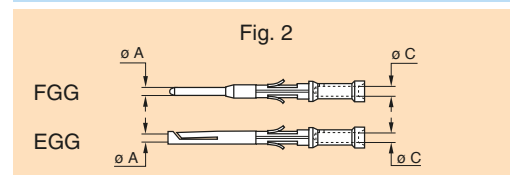
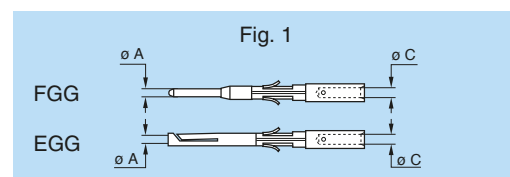

Note: a wide variation of strand number and diameter combinations are quoted as being AWG, some of which do not have a large enough cross section to guarantee a crimp as per either MIL-C-22520/1-01 or /7-01.

FGG-EGG Insulators

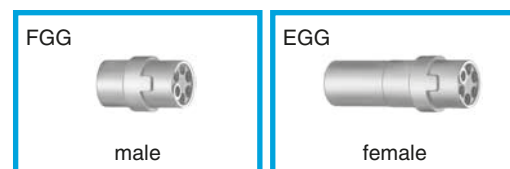

Note: each insulator can be used both for crimp contacts of normal shape (fig. 1) or with reduced crimp barrel (fig. 2).

DCE Positioners ø 0.5-0.7-0.9-1.3 mm ¹⁾



These positioners are suitable for use with both manual and pneumatic crimping tools according to the MIL-C-22520/7-01 standard.

DCE Turret for ø 1.6-2.0-3.0-4.0 mm ¹⁾



Note: these turrets can be used with manual crimping tool according to MIL-C-22520/1-01 standard.

DCC Manual extractors

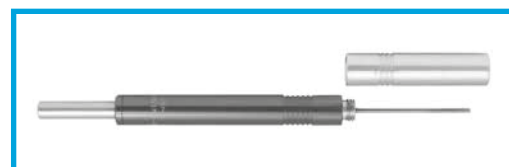

Spare parts for crimp contacts

	Types	Insulator part number		ø (mm)		F.Ø.	Cond. AWG		Contact part number		
		Male contact	Female contact	A	C		min.	max.	Male	Female	
3B 3K 3T	302	FGG.3B.302.YL	EGG.3B.402.YL	3.0	3.20	1	14	10	FGG.3B.580.ZZC	EGG.3B.680.ZZM	
	303/304/309	FGG.3B.30●.YL ¹⁾	EGG.3B.40●.YL ¹⁾	2.0		2.40	1	16	12	FGG.3B.575.ZZC	EGG.3B.675.ZZM
						1.90	2	18	14	FGG.3B.576.ZZC	EGG.3B.676.ZZM
	305/306/307	FGG.3B.30●.YL	EGG.3B.40●.YL	1.6		1.90	1	18	14	FGG.3B.570.ZZC	EGG.3B.670.ZZM
						1.40	2	22	18	FGG.3B.571.ZZC	EGG.3B.671.ZZM
	308/309/310	FGG.3B.3●●.YL ¹⁾	EGG.3B.4●●.YL ¹⁾	1.3		1.40	1	20	18	FGG.3B.565.ZZC	EGG.3B.665.ZZM
						1.10	2	24	20	FGG.3B.566.ZZC	EGG.3B.666.ZZM
0.80						2	26	22	FGG.3B.567.ZZC	EGG.3B.667.ZZM	
312/314 316/318	FGG.3B.3●●.YL	EGG.3B.4●●.YL	0.9		1.10	1	24	20	FGG.3B.560.ZZC	EGG.3B.660.ZZM	
					0.80	2	26	22	FGG.3B.561.ZZC	EGG.3B.661.ZZM	
					0.45	2	32	28	FGG.3B.562.ZZC	EGG.3B.662.ZZM	
320/322/324 326/330/332	FGG.3B.3●●.YL	EGG.3B.4●●.YL	0.7		0.80	1	26	22	FGG.3B.555.ZZC	EGG.3B.655.ZZM	
					0.45	2	32	28	FGG.3B.556.ZZC	EGG.3B.656.ZZM	
4B 4K	304	FGG.4B.304.YL	EGG.4B.404.YL	3.0	3.20	1	14	10	FGG.4B.580.ZZC	EGG.4B.680.ZZM	
	306/307	FGG.4B.30●.YL	EGG.4B.40●.YL	2.0		2.40	1	16	12	FGG.4B.575.ZZC	EGG.4B.675.ZZM
						1.90	2	18	14	FGG.4B.576.ZZC	EGG.4B.676.ZZM
	310	FGG.4B.310.YL	EGG.4B.410.YL	1.6		1.90	1	18	14	FGG.4B.570.ZZC	EGG.4B.670.ZZM
						1.40	2	22	18	FGG.4B.571.ZZC	EGG.4B.671.ZZM
	312	FGG.4B.312.YL	EGG.4B.412.YL	1.3		1.40	1	20	18	FGG.4B.565.ZZC	EGG.4B.665.ZZM
						1.10	2	24	20	FGG.4B.566.ZZC	EGG.4B.666.ZZM
316/320 324/330	FGG.4B.3●●.YL	EGG.4B.4●●.YL	0.9		1.10	1	24	20	FGG.4B.560.ZZC	EGG.4B.660.ZZM	
					0.80	2	26	22	FGG.4B.561.ZZC	EGG.4B.661.ZZM	
340/348	FGG.4B.3●●.YL	EGG.4B.4●●.YL	0.7		0.80	1	26	22	FGG.4B.555.ZZC	EGG.4B.655.ZZM	
					0.45	2	32	28	FGG.4B.556.ZZC	EGG.4B.656.ZZM	
5B 5K	304	FGG.5B.304.ML	EGG.5B.404.ML	4.0	4.00	1	12	10	FGG.5B.582.ZZC	EGG.5B.682.ZZM	
	310	FGG.5B.310.YL	EGG.5B.410.YL	3.0	3.20	1	14	10	FGG.5B.580.ZZC	EGG.5B.680.ZZM	
	314/316	FGG.5B.3●●.YL	EGG.5B.4●●.YL	2.0		2.40	1	16	12	FGG.5B.575.ZZC	EGG.5B.675.ZZM
						1.90	2	18	14	FGG.5B.576.ZZC	EGG.5B.676.ZZM
	320	FGG.5B.320.YL	EGG.5B.420.YL	1.6		1.90	1	18	14	FGG.5B.570.ZZC	EGG.5B.670.ZZM
						1.40	2	22	18	FGG.5B.571.ZZC	EGG.5B.671.ZZM
	330/340/348	FGG.5B.3●●.YL	EGG.5B.4●●.YL	1.3		1.40	1	20	18	FGG.5B.565.ZZC	EGG.5B.665.ZZM
1.10						2	24	20	FGG.5B.566.ZZC	EGG.5B.666.ZZM	
350/354/364	FGG.5B.3●●.YL	EGG.5B.4●●.YL	0.9		0.80	2	26	22	FGG.5B.567.ZZC	EGG.5B.667.ZZM	
					1.10	1	24	20	FGG.5B.560.ZZC	EGG.5B.660.ZZM	
					0.80	2	26	22	FGG.5B.561.ZZC	EGG.5B.661.ZZM	

Note: ¹⁾ for 309 type the insulator part number is FGG.3B.309.ML (male contact) and EGG.3B.409.ML (female contact).

● Standard ● Special

Tools for crimp contacts

	Types	Positioners part number ¹⁾		Extractors part number for male/female contacts
		Male contact	Female contact	
3B 3K 3T	302	DCE.91.303.BVCM		DCC.30.35B.LAG
	303/304/309	DCE.91.203.BVCM		DCC.20.25B.LAG
	305/306/307	DCE.91.163.BVCM		DCC.16.25B.LAG
	308/309/310	DCE.91.133.BVC	DCE.91.133.BVM	DCC.13.15B.LAG
	312/314 316/318	DCE.91.093.BVC	DCE.91.093.BVM	DCC.09.05B.LAG
		DCE.91.093.BVG ²⁾	DCE.91.093.BVU ²⁾	
	320/322/324 326/330/332	DCE.91.073.BVC	DCE.91.073.BVM	DCC.07.04B.LAG
4B 4K	304	DCE.91.304.BVCM		DCC.30.35B.LAG
	306/307	DCE.91.204.BVCM		DCC.20.25B.LAG
	310	DCE.91.164.BVCM		DCC.16.25B.LAG
	312	DCE.91.134.BVC	DCE.91.134.BVM	DCC.13.15B.LAG
	316/320 324/330	DCE.91.094.BVC	DCE.91.094.BVM	DCC.09.05B.LAG
	340/348	DCE.91.074.BVC	DCE.91.074.BVM	DCC.07.04B.LAG
	5B 5K	304	DCE.91.405.BVCM	
310		DCE.91.305.BVCM		DCC.30.35B.LAG
314/316		DCE.91.205.BVCM		DCC.20.25B.LAG
320		DCE.91.165.BVCM		DCC.16.25B.LAG
330/340/348		DCE.91.135.BVC	DCE.91.135.BVM	DCC.13.15B.LAG
		DCE.91.135.BVG	DCE.91.135.BVU	
350/354/364		DCE.91.095.BVC	DCE.91.095.BVM	DCC.09.05B.LAG

Note:

¹⁾ please consult page 92 for the corresponding crimping tools.

²⁾ «G» and «U» positioners for reduced crimp barrel (see p. 78 - fig. 2 for contact type details).

FGG-EGG Crimp contacts

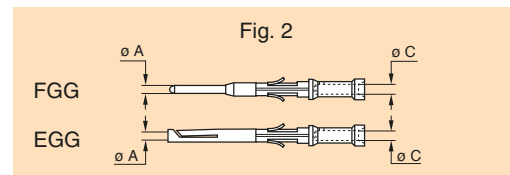
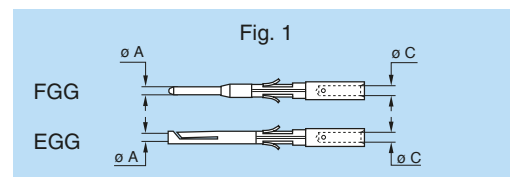

Note: a wide variation of strand number and diameter combinations are quoted as being AWG, some of which do not have a large enough cross section to guarantee a crimp as per either MIL-C-22520/1-01 or /7-01.

FGG-EGG Insulators

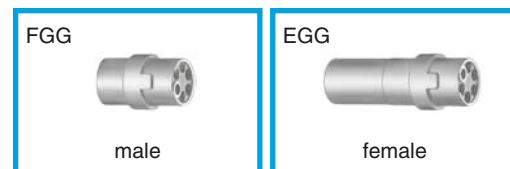

Note: each insulator can be used both for crimp contacts of normal shape (fig. 1) or with reduced crimp barrel (fig. 2).

DCE Positioners ø 0.5-0.7-0.9-1.3 mm ¹⁾



These positioners are suitable for use with both manual and pneumatic crimping tools according to the MIL-C-22520/7-01 standard.

DCE Turret for ø 1.6-2.0-3.0-4.0 mm ¹⁾



Note: these turrets can be used with manual crimping tool according to MIL-C-22520/1-01 standard.

DCC Manual extractors

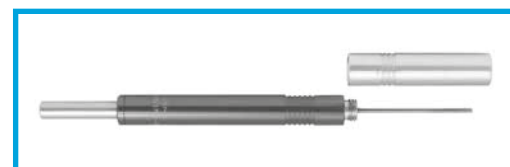

Crimping tools for electrical contacts

Manual crimping tools

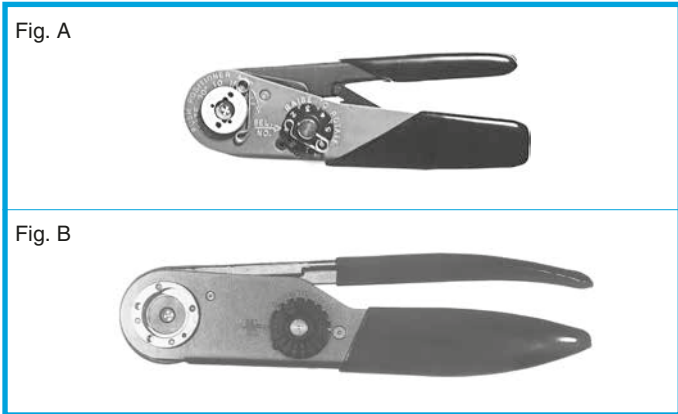

Part number			Supplier
contact \varnothing 0.5-0.7 0.9-1.3 (Fig. A)	contact \varnothing 1.6-2.0 (Fig. B)	contact \varnothing 3.0-4.0 (Fig. B)	
DPC.91.701.V¹⁾	DPC.91.101.A²⁾	DPC.91.102.V	LEMO
MH860¹⁾	AF8²⁾	M300BT	DANIELS
616336¹⁾	615708²⁾	-	ASTRO

1) According to specification MIL-C-22520/7-01.
2) According to specification MIL-C-22520/1-01.

Pneumatic crimping tools

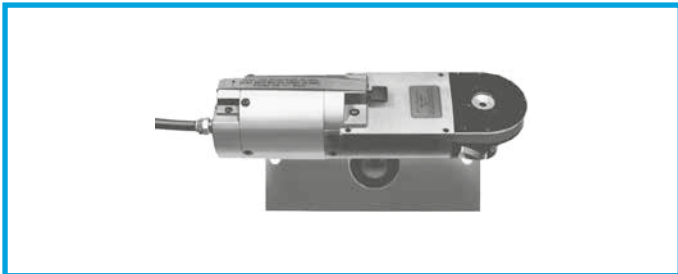

Part number	Supplier
DPC.91.701.C	LEMO

According to specification MIL-C-22520/7-01.
For LEMO contacts \varnothing 0.5-0.7-0.9-1.3 mm

Spare parts

GBA Locking washers

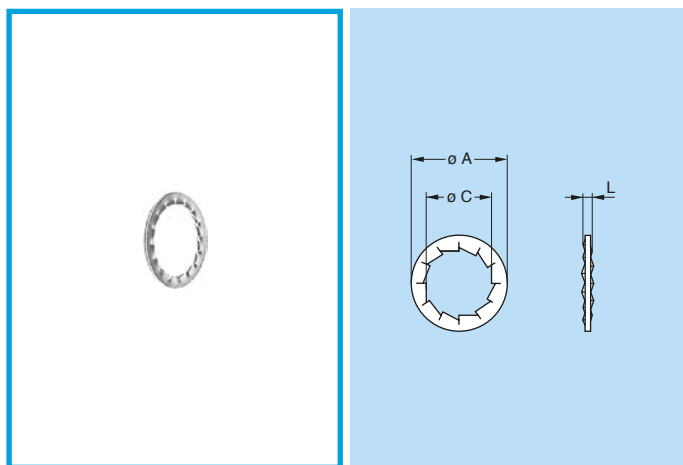

- Material: Nickel-plated bronze (3 μm)

Part number	Series	Dimensions (mm)		
		A	C	L
GBA.00.250.FN	00-TT	9.5	7.1	1.0
GBA.0S.250.FN	0B-0T	12.5	9.1	1.0
GBA.1S.250.FN	1B-1T	16.0	12.1	1.0
GBA.0E.250.FN	XB	19.6	14.1	1.2
GBA.1E.250.FN	1K	21.8	16.1	1.2
GBA.2S.250.FN	2B-2T	19.5	15.1	1.2
GBA.3S.250.FN	3B-3T	25.0	18.1	1.4
GBA.4S.250.FN	4B	32.0	25.1	1.4

Note: to order this accessory separately, use the above part numbers.

- Standard
- Special

GBB Tapered washers

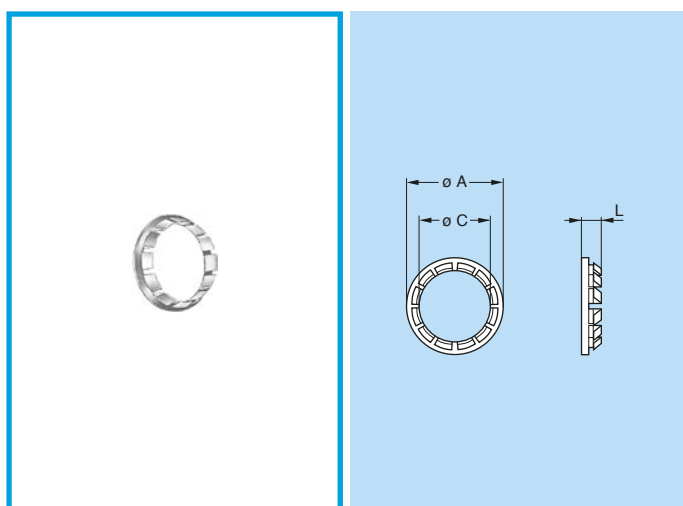

- Material: Nickel-plated brass (3 μm)

Part number	Series	Dimensions (mm)		
		A	C	L
GBB.00.250.LN	00	9	7.1	2.0
GBB.0S.250.LN	0B	11	9.1	2.5
GBB.1S.250.LN	1B	15	12.1	3.5
GBB.2S.250.LN	2B	18	15.1	4.0
GBB.3S.250.LN	3B	22	18.1	4.5
GBB.4S.250.LN	4B	28	25.2	5.0
GBB.5S.250.LN	5B	40	35.2	7.5

Note: sockets of series 5B are always supplied with a tapered washer. To order this accessory separately, use the above part numbers. The panel cut out diameters are larger when using tapered washer.

- Standard
- Special

GEG Notched nut

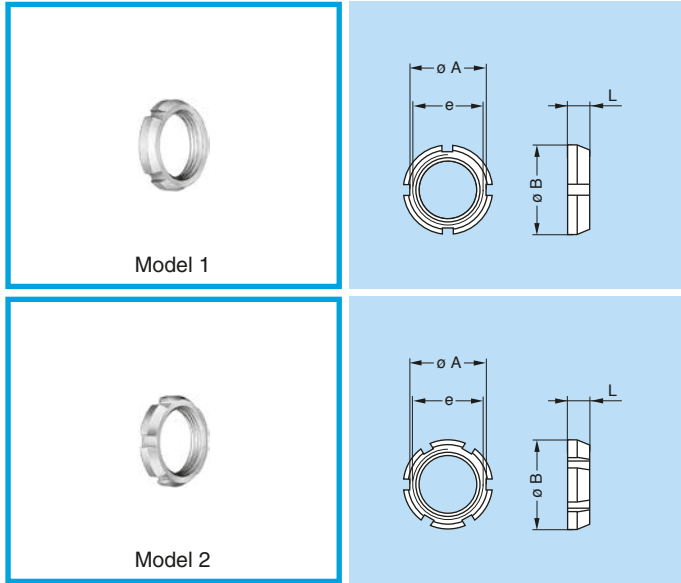

Part number	Model	Dimensions (mm)			
		A	B	e	L
GEG.00.240.LC	1	8.6	10	M7 x 0.5	2.5
GEG.0S.240.LC	1	10.5	12	M9 x 0.6	2.5
GEG.0E.240.LC	1	15.8	18	M14 x 1.0	3.5
GEG.1S.240.LC	1	14.0	16	M12 x 1.0	3.5
GEG.1E.240.LC	2	17.5	20	M16 x 1.0	3.5
GEG.1S.242.LC	1	12.1	14	M11 x 0.5	3.5
GEG.2S.240.LC	2	17.5	20	M15 x 1.0	3.5
GEG.2S.241.LC	2	20.5	24	M19 x 1.0	3.5
GEG.2E.240.LC	2	22.5	25	M20 x 1.0	3.5

Note: 00, TT, 0B, 0T, 1B, 1T, 2B and 2T series sockets and fixed cable sockets for back panel mounting are always delivered with this notched nut. To order this accessory separately, use the above part numbers.

- Material: Chrome-plated brass (Ni 3 μ m + Cr 0.3 μ m)

GEA Hexagonal nuts

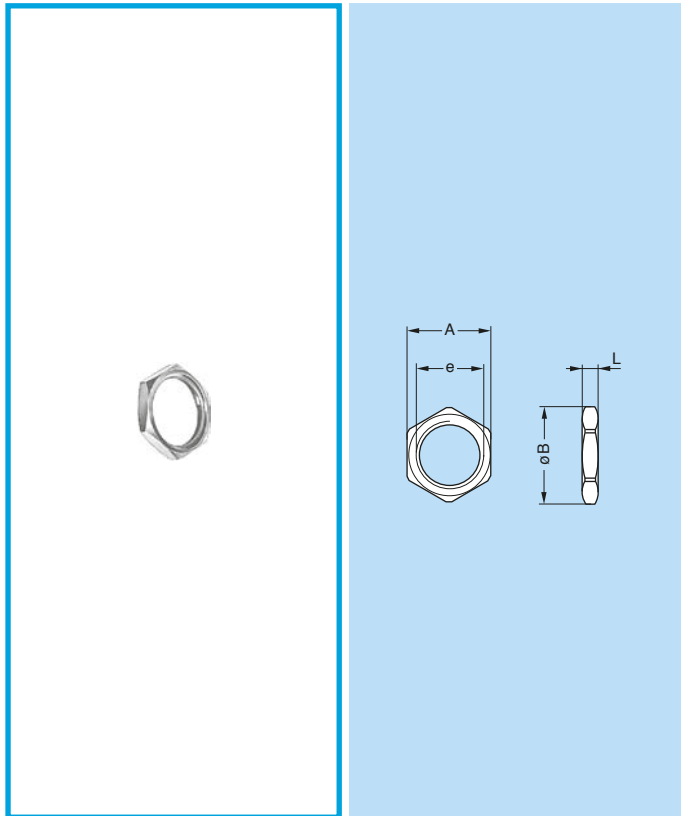

Part number	Series	Dimensions (mm)			
		A	B	e	L
GEA.00.240.LN	00-TT	9	10.2	M7 x 0.50	2.0
GEA.0S.240.LN	0B-0T	11	12.4	M9 x 0.60	2.0
GEA.0S.241.LN	0B	12	13.8	M10 x 0.75	2.5
GEA.0E.240.LN	0K	17	19.2	M14 x 1.00	2.5
	1B-XB				
GEA.1S.240.LN	1B-1T	14	15.8	M12 x 1.00	2.5
GEA.1S.241.LN	1B	13	14.8	M11 x 0.50	2.5
GEA.1E.240.LN	1K	19	21.5	M16 x 1.00	3.0
	2B				
GEA.2S.240.LN	2B-2T	17	19.2	M15 x 1.00	2.7
GEA.2E.240.LN	2K	24	27.0	M20 x 1.00	4.0
GEA.3S.240.LN	3B-3T	22	25.0	M18 x 1.00	3.0
GEA.3E.240.LN	3K	30	34.0	M24 x 1.00	5.0
GEA.4S.240.LN	4B	30	34.0	M25 x 1.00	5.0
GEA.4E.240.LN	4K	36	40.5	M30 x 1.00	7.0

Note: to order this part separately, use the above part numbers. The last letters «LN» of the part number refer to the nut material and treatment. If a nut in aluminium alloy or stainless steel is desired, replace the last letters of the part number by «PT» or «AZ» respectively.

- Material: Nickel-plated brass (3 μ m), natural anodized aluminium alloy, stainless steel

- Standard ● Special

GEC Conical nuts

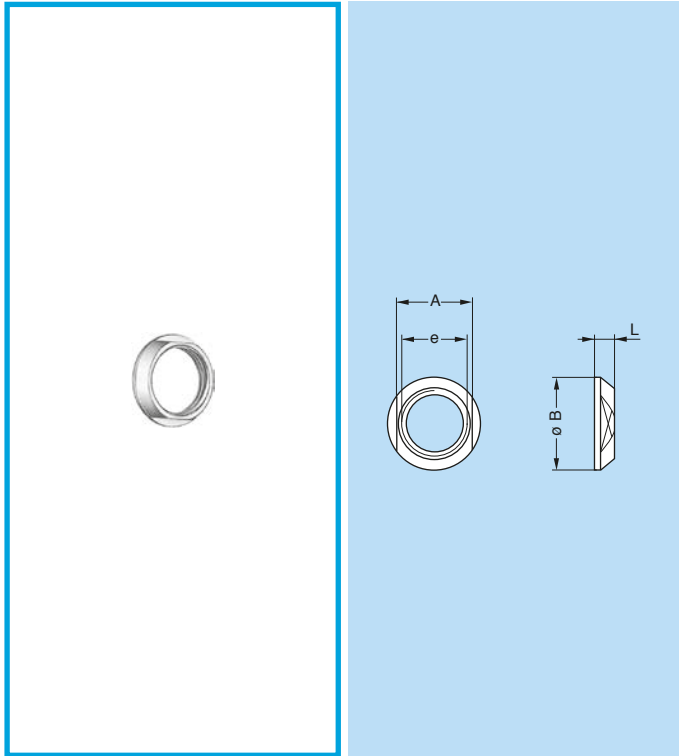

Part number	Dimensions (mm)			
	A	B	e	L
GEC.00.240.LC	8	10.0	M7 x 0.5	2.5
GEC.0S.240.LC	10	12.0	M9 x 0.6	2.5
GEC.0E.240.LC	16	18.0	M14 x 1.0	3.0
GEC.1S.240.LC	13	16.0	M12 x 1.0	3.2
GEC.1S.241.LC	17	20.0	M16 x 1.0	4.0
GEC.1S.242.LC	12	14.0	M11 x 0.5	3.2
GEC.2S.240.LC	17	20.0	M15 x 1.0	3.8
GEC.2S.241.LC	20	24.0	M19 x 1.0	5.8
GEC.2E.240.LC	22	25.0	M20 x 1.0	5.0
GEC.3S.240.LC	20	24.0	M18 x 1.0	4.5
GEC.3E.240.LC	27	30.0	M24 x 1.0	4.5
GEC.4S.240.LC	27	30.0	M25 x 1.0	4.5
GEC.4K.241.LC	32	35.5	M30 x 1.0	5.0
GEC.5S.240.LC	37	41.0	M35 x 1.0	5.0

Note: 3B, 3K, 3T, 4B, 4K, 5B and 5K series sockets and fixed cable sockets for back panel mounting are always delivered with a conical nut. To order this accessory separately, use the part numbers in the adjacent table.

● Material: Chrome-plated brass (Ni 3 μ m + Cr 0.3 μ m)

● Standard ● Special

GEB Round nuts

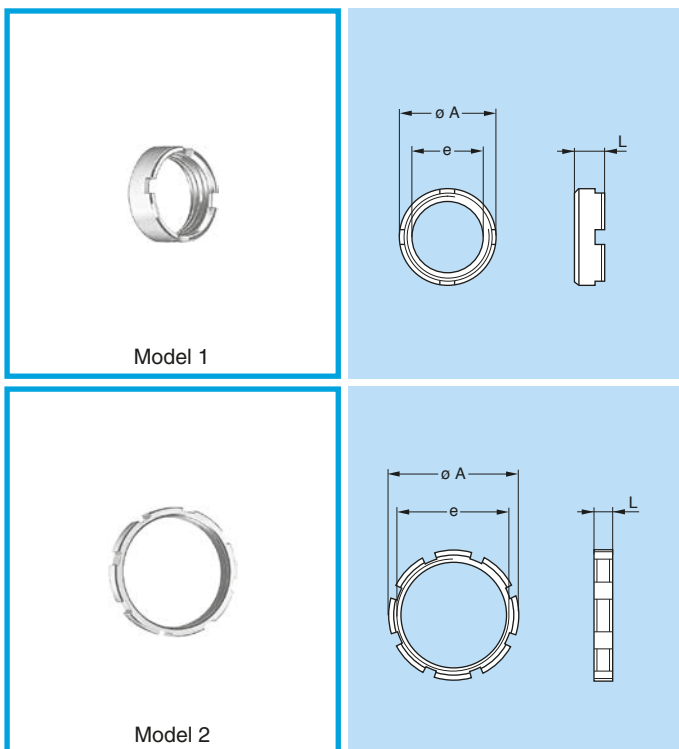

Part number	Model	Dimensions (mm)		
		A	e	L
GEB.00.240.LN	1	9.0	M7 x 0.50	4.0
GEB.0S.240.LN	1	11.0	M9 x 0.60	4.0
GEB.0E.240.LN	1	18.0	M14 x 1.00	5.0
GEB.1S.240.LN	1	14.0	M12 x 1.00	5.0
GEB.1E.240.LN	1	20.0	M16 x 1.00	5.0
GEB.2S.240.LN	1	18.0	M15 x 1.00	5.5
GEB.2B.240.LN	1	17.5	M15 x 0.75	2.5
GEB.3S.240.LN	1	22.0	M18 x 1.00	5.5
GEB.4S.240.LN	1	28.0	M25 x 1.00	6.0
GEB.5S.240.LN	2	40.0	M35 x 1.00	8.0
GEB.5E.240.LN	2	54.0	M45 x 1.50	8.0

Note: 5B and 5K series sockets and fixed cable sockets are always supplied with model 2 round nuts. To order this accessory separately, use the above part numbers.

● Material: Nickel-plated brass (3 μ m)

● Standard ● Special

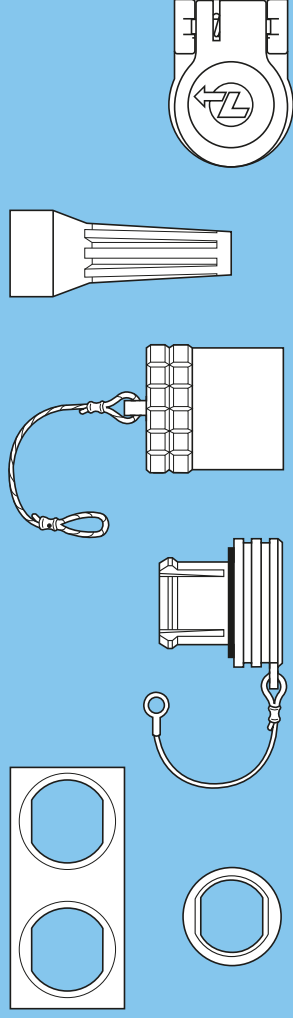

ACCESSORIES

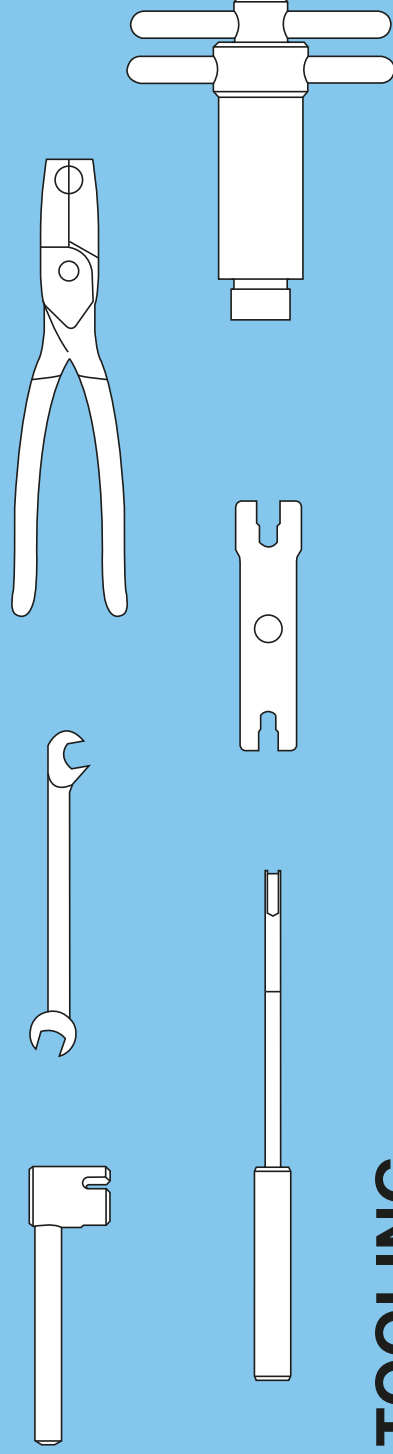

TOOLING

Accessories

BFG Plug caps

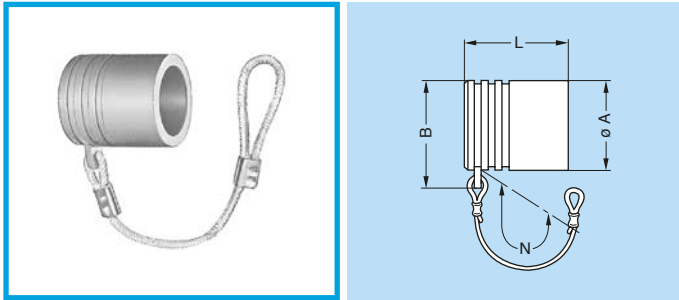

- Body material: Polyoxymethylene (POM) grey (or black)
- Cord material: Polypropylene core and PVC coat, grey (or black)
- Gasket material: Silicone rubber
- Maximum operating temperature: 100°C
- Watertightness: IP51 according to IEC 60529

Part number	Series	Dimensions (mm)			
		A	B	L	N ¹⁾
BFG.00.100.PCSG	00	7.5	9.8	10.0	60
BFG.0B.100.PCZG	0B	9.5	12.5	11.2	85
BFG.1B.100.PCZG	1B	12.0	15.5	12.3	85
BFG.2B.100.PCSG	2B	15.0	18.0	15.0	85
BFG.3B.100.PCSG	3B	18.5	22.0	18.5	95

Note: ¹⁾ the tolerance on this dimension is ± 5 mm.
This cap is available only with an alignment key (G). Upon request this cap can be supplied in black and the last letter «G» of the part number should be replaced with «N».

Fitting the cord

Slide the plug into the loop of the cord.
Place the loop into the groove in front of the collet nut and tighten the loop.

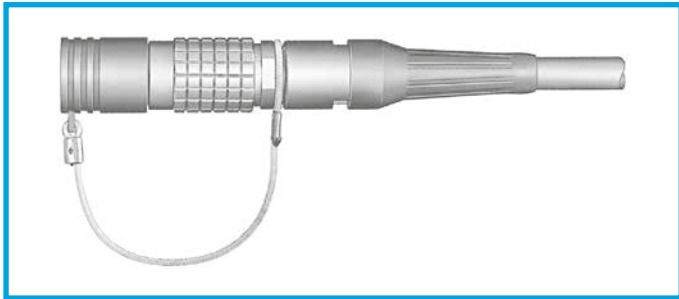

BFG Plug caps with key (G)

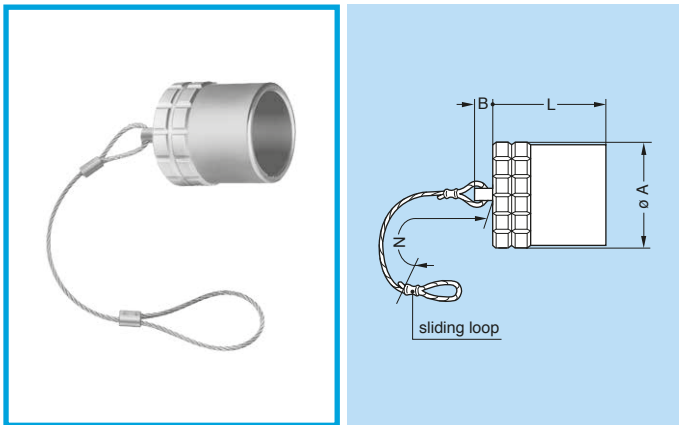

- Body material: Nickel-plated brass (Ni 3µm)
- Lanyard material: Stainless steel
- Crimp ferrule material: Nickel-plated brass + polyolefin
- O-ring material: Silicone rubber or FPM
- Operating temperature: -50°/135°C (Silicone rubber & Polyolefine)
- Watertightness: IP68 according to IEC 60529 for K series

Part number	Series	Dimensions (mm)			
		A	B	L	N ¹⁾
BFG.0K.100.NAS	0K	14.0	6	12.5	85
BFG.1K.100.NAS	1K	16.0	6	15.5	85
BFG.2K.100.NAS	2K	19.5	6	17.5	85
BFG.3K.100.NAS	3K	23.0	6	22.0	120
BFG.4B.100.NAS	4B	25.0	10	20.2	120
BFG.4K.100.NAS	4K	29.0	10	22.5	120
BFG.5B.100.NAS	5B	36.0	10	27.2	150
BFG.5K.100.NAS	5K	44.0	10	27.0	150

Note: ¹⁾ the tolerance on this dimension is ± 5 mm.
This cap is available only with an alignment key (G). The last letter «S» of the part number stands for the material of the O-ring (silicone rubber). O-ring's made from FPM are also available; if required, replace the letter «S» by «V».

- Standard
- Special

BHG Plug caps, nut fixing or flange

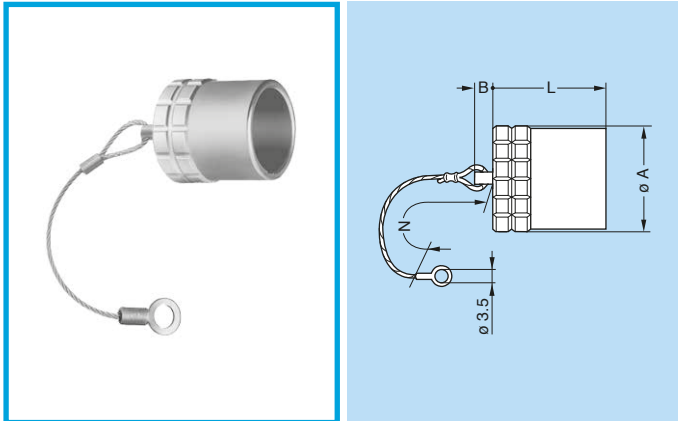

- Body material: Nickel-plated brass (Ni 3µm)
- Lanyard material: Stainless steel
- Crimp ferrule material: Nickel-plated brass + polyolefin
- O-ring material: Silicone rubber or FPM
- Operating temperature: -50°/135°C (Silicone rubber & Polyolefine)
- Watertightness: IP68 according to IEC 60529 for K series

Part number	Series	Dimensions (mm)			
		A	B	L	N ¹⁾
BHG.0K.100.NAS	0K	14.0	6	12.5	85
BHG.1K.100.NAS	1K	16.0	6	15.5	85
BHG.2K.100.NAS	2K	19.5	6	17.5	85
BHG.3K.100.NAS	3K	23.0	6	22.0	120
BHG.4B.100.NAS	4B	25.0	10	20.2	120
BHG.4K.100.NAS	4K	29.0	10	22.5	120
BHG.5B.100.NAS	5B	36.0	10	27.2	150
BHG.5K.100.NAS	5K	44.0	10	27.0	150

Note: 1) the tolerance on this dimension is ± 5 mm.
This cap is available only with an alignment key (G). The last letter «S» of the part number stands for the material of the O-ring (silicone rubber). O-ring's made from FPM are also available; if required, replace the letter «S» by «V».

- Standard
- Special

BFG Plug cap

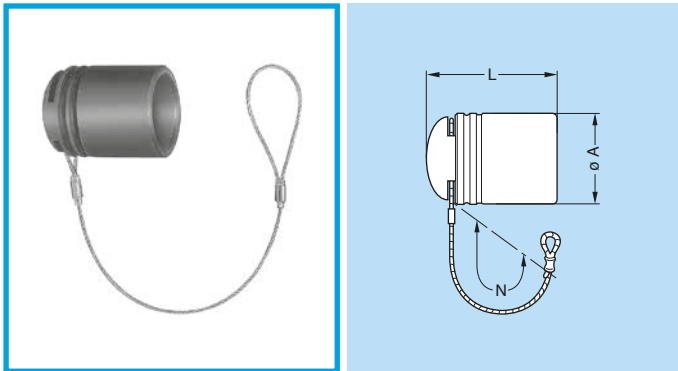

Part number	Series	Dimensions (mm)		
		A	L	N ¹⁾
BFG.3K.100.EAN	3K	26	31	155

- Material: black MPR (Melt-Processable Rubber)
- Lanyard material: Stainless steel
- Crimp ferrule material: Stainless steel AISI 304 + polyolefin

Note: 1) the tolerance on this dimension is ± 5 mm.
These caps are suitable for use with any alignment key configuration.

BHA Plug cap

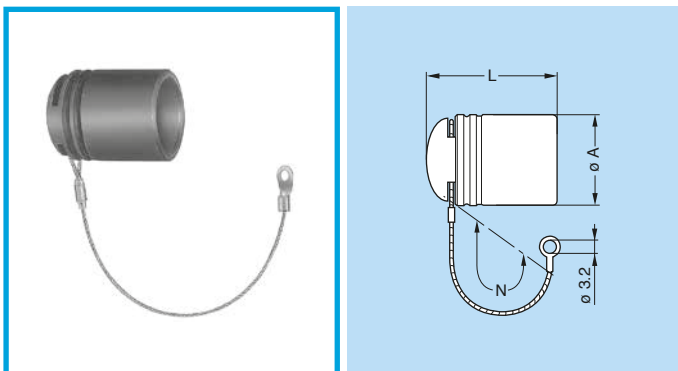

Part number	Series	Dimensions (mm)		
		A	L	N ¹⁾
BHA.3K.100.EAN	3K	26	31	120

- Material: black MPR (Melt-Processable Rubber)
- Lanyard material: Stainless steel
- Crimp ferrule material: Stainless steel AISI 304 + polyolefin

Note: 1) the tolerance on this dimension is ± 5 mm.
These caps are suitable for use with any alignment key configuration.

BRA Blanking caps for sockets and fixed cable sockets

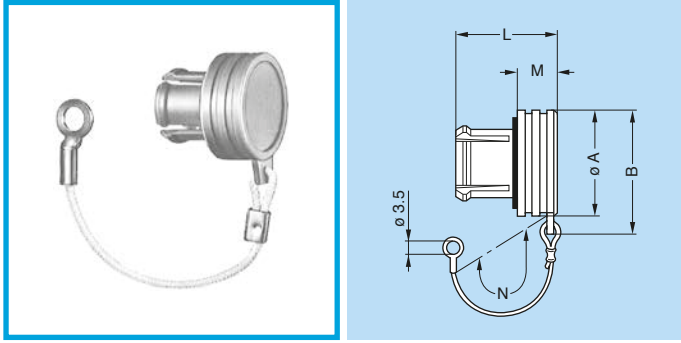

- Body material: Polyoxymethylene (POM) grey (or black)
- Cord material: Polypropylene core and PVC coat, grey (or black)
- Gasket material: Silicone rubber
- Maximum operating temperature: 100°C
- Watertightness: IP61 according to IEC 60529

Part number	Series	Dimensions (mm)				
		A	B	L	M	N ¹⁾
BRA.00.200.PCSG	00	7.5	9.8	9.0	3.5	60
BRA.0B.200.PCSG	0B	10.0	12.5	11.0	4.8	60
BRA.1B.200.PCSG	1B	14.0	17.0	13.5	5.6	60
BRA.2B.200.PCSG	2B	18.0	21.0	14.5	6.0	60
BRA.3B.200.PCSG	3B	22.0	25.5	17.0	7.0	60

Note: ¹⁾ the tolerance on this dimension is ± 5 mm. These caps are suitable for use with any alignment key configuration. On request this cap can be supplied in black. If so, replace the last letter «G» of the part number by «N».

BRE Blanking caps for sockets and fixed cable sockets

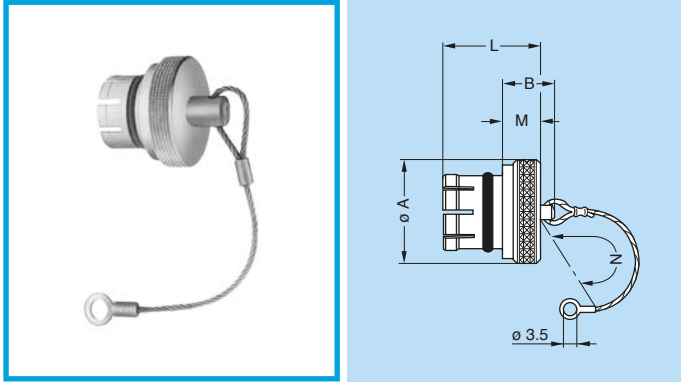

- Body material: Nickel-plated brass (Ni 3 µm)
- Lanyard material: Stainless steel
- Crimp ferrule material: Nickel-plated brass + polyolefin
- O-ring material: Silicone rubber or FPM
- Operating temperature: -50°/135°C (Silicone rubber & Polyolefine)
- Watertightness: IP61 according to IEC 60529

Part number	Series	Dimensions (mm)				
		A	B	L	M	N ¹⁾
BRE.00.200.NAS	00	8	7.5	8.8	3.5	60
BRE.0S.200.NAS	0B	10	9.5	10.5	4.5	85
BRE.1S.200.NAS	1B	14	11.0	12.5	5.0	85
BRE.2S.200.NAS	2B	18	12.0	14.0	6.0	85
BRE.3S.200.NAS	3B	22	14.0	18.0	8.0	120
BRE.4S.200.NAS	4B	28	20.0	23.0	10.0	120
BRE.5S.200.NAS	5B	40	22.0	30.0	12.0	150

Note: ¹⁾ the tolerance on this dimension is ± 5 mm. These caps are suitable for use with any alignment key configuration. The last letter «S» of the part number stands for the O-ring material (silicone rubber). O-ring's made from FPM are also available; if required, replace the letter «S» by «V».

- Standard
- Special

BRE Blanking caps for sockets and fixed cable sockets

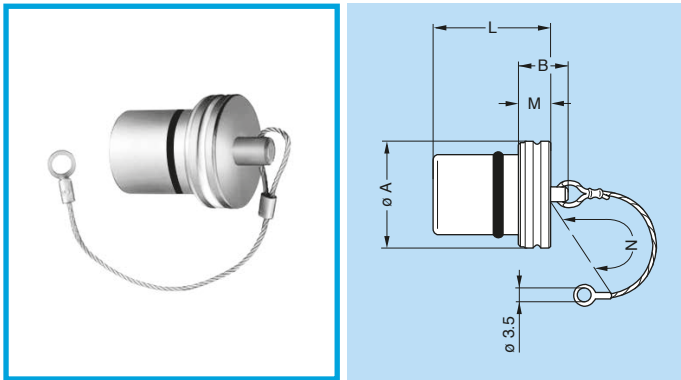

- Body material: Nickel-plated brass (Ni 3 µm)
- Lanyard material: Stainless steel
- Crimp ferrule material: Nickel-plated brass + polyolefin
- O-ring material: Silicone rubber or FPM
- Operating temperature: -50°/135°C (Silicone rubber & Polyolefine)
- Watertightness: IP68 according to IEC 60529

Part number	Series	Dimensions (mm)				
		A	B	L	M	N ¹⁾
BRE.0K.200.NAS	0K	15.0	10	15.0	4	85
BRE.1K.200.NAS	1K	17.0	12	20.0	6	85
BRE.2K.200.NAS	2K	20.5	14	24.0	8	85
BRE.3K.200.NAS	3K	24.0	14	28.0	8	120
BRE.4K.200.NAS	4K	30.0	20	30.5	10	120
BRE.5K.200.NAS	5K	44.0	22	37.0	12	150

Note: ¹⁾ the tolerance on this dimension is ± 5 mm. These caps are suitable for use with any alignment key configuration. The last letter «S» of the part number stands for the O-ring material (silicone rubber). O-ring's made from FPM are also available; if required, replace the letter «S» by «V».

- Standard
- Special

BRA Blanking caps for sockets and fixed cable sockets

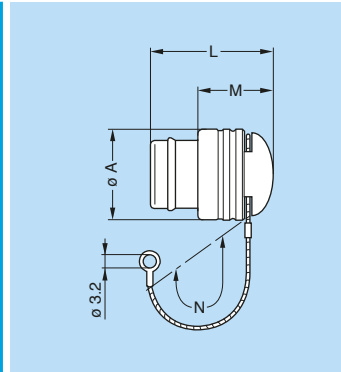
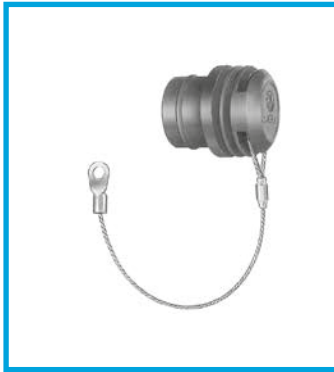

Part number	Series	Dimensions (mm)			
		A	L	M	N ¹⁾
BRA.3K.200.EAN	3K	26	27	14.5	120
BRA.4K.200.EAN	4K	31	31	17.0	120

- Material: black MPR (Melt-Processable Rubber)
- Lanyard material: Stainless steel
- Crimp ferrule material: Stainless steel AISI 304 + polyolefin

Note: ¹⁾ the tolerance on this dimension is ± 5 mm. These caps are suitable for use with any alignment key configuration.

- Standard
- Special

BRF Blanking caps for free cable sockets

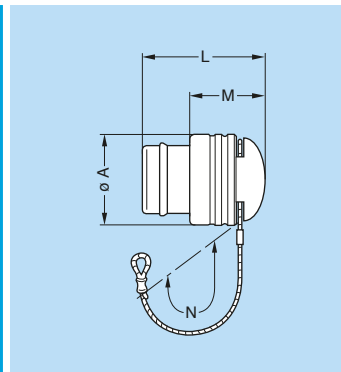

Part number	Series	Dimensions (mm)			
		A	L	M	N ¹⁾
BRF.3K.200.EAN	3K	26	27	14.5	155

- Material: black MPR (Melt-Processable Rubber)
- Lanyard material: Stainless steel
- Crimp ferrule material: Stainless steel AISI 304 + polyolefin

Note: ¹⁾ the tolerance on this dimension is ± 5 mm. These caps are suitable for use with any alignment key configuration.

BRD Blanking caps for free cable sockets

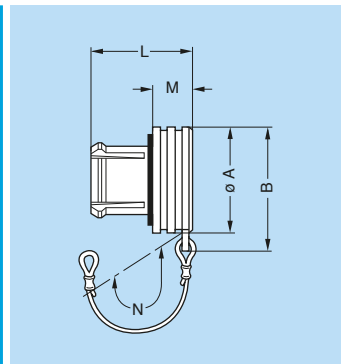

Part number	Series	Dimensions (mm)				
		A	B	L	M	N ¹⁾
BRD.00.200.PCSG	00	7.5	9.8	9.0	3.5	85
BRD.0B.200.PCSG	0B	10.0	12.5	11.0	4.8	85
BRD.1B.200.PCSG	1B	14.0	17.0	13.5	5.6	85
BRD.2B.200.PCSG	2B	18.0	21.0	14.5	6.0	85
BRD.3B.200.PCSG	3B	22.0	25.5	17.0	7.0	95

- Body material: Polyoxymethylene (POM) grey (or black)
- Cord material: Polypropylene core and PVC coat, grey (or black)
- Gasket material: Silicone rubber
- Maximum operating temperature: 100°C
- Watertightness: IP61 according to IEC 60529

Note: ¹⁾ the tolerance on this dimension is ± 5 mm. On request this cap is available in black. If required, replace the last letter «G» of the part number by «N».

Fitting the cord

Slide the free cable socket into the loop of the cord. Place the loop into the groove in front of the collet nut. Tighten the loop.

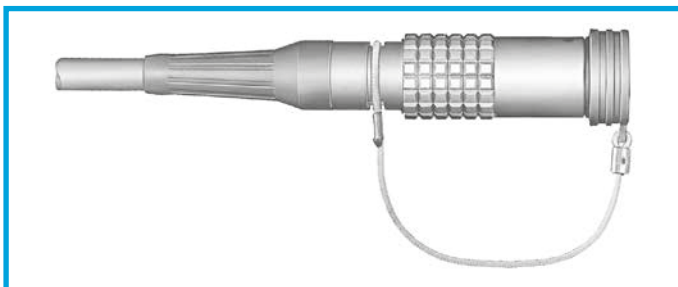

BRF Blanking caps for free cable sockets

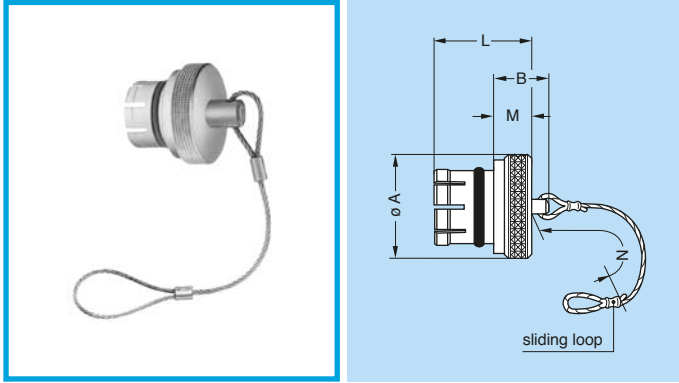

- Body material: Nickel-plated brass (Ni 3 µm)
- Lanyard material: Stainless steel
- Crimp ferrule material: Nickel-plated brass + polyolefin
- O-ring material: Silicone rubber or FPM
- Operating temperature: -50°/135°C (Silicone rubber & Polyolefine)
- Watertightness: IP61 according to IEC 60529

Part number	Series	Dimensions (mm)				
		A	B	L	M	N ¹⁾
BRF.00.200.NAS	00	8	7.5	8.8	3.5	85
BRF.0S.200.NAS	0B	10	9.5	10.5	4.5	85
BRF.1S.200.NAS	1B	14	11.0	12.5	5.0	85
BRF.2S.200.NAS	2B	18	12.0	14.0	6.0	85
BRF.3S.200.NAS	3B	22	14.0	18.0	8.0	120
BRF.4S.200.NAS	4B	28	20.0	23.0	10.0	120
BRF.5S.200.NAS	5B	40	22.0	30.0	12.0	150

Note: ¹⁾ the tolerance on this dimension is ± 5 mm. These caps are suitable for use with any alignment key configuration. The last letter «S» of the part number stands for the O-ring material (silicone rubber). O-ring's made from FPM are also available; if required, replace the letter «S» by «V».

- Standard
- Special

BRF Blanking caps for free cable sockets

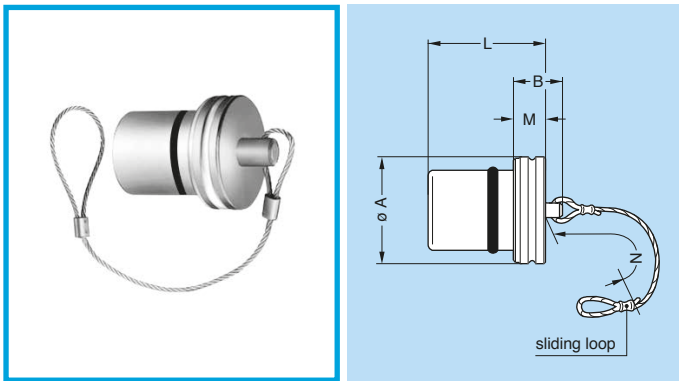

- Body material: Nickel-plated brass (Ni 3 µm)
- Lanyard material: Stainless steel
- Crimp ferrule material: Nickel-plated brass + polyolefin
- O-ring material: Silicone rubber or FPM
- Operating temperature: -50°/135°C (Silicone rubber & Polyolefine)
- Watertightness: IP68 according to IEC 60529

Part number	Series	Dimensions (mm)				
		A	B	L	M	N ¹⁾
BRF.0K.200.NAS	0K	15.0	10	15.0	4	85
BRF.1K.200.NAS	1K	17.0	12	20.0	6	85
BRF.2K.200.NAS	2K	20.5	14	24.0	8	85
BRF.3K.200.NAS	3K	24.0	14	28.0	8	120
BRF.4K.200.NAS	4K	30.0	20	30.5	10	120
BRF.5K.200.NAS	5K	44.0	22	37.0	12	150

Note: ¹⁾ the tolerance on this dimension is ± 5 mm. These caps are suitable for use with any alignment key configuration. The last letter «S» of the part number stands for the O-ring material (silicone rubber). O-ring's made from FPM are also available; if required, replace the letter «S» by «V».

- Standard
- Special

BRR Spring loaded dust caps for ERA, ERN and EG sockets or PSA and PK fixed cable sockets

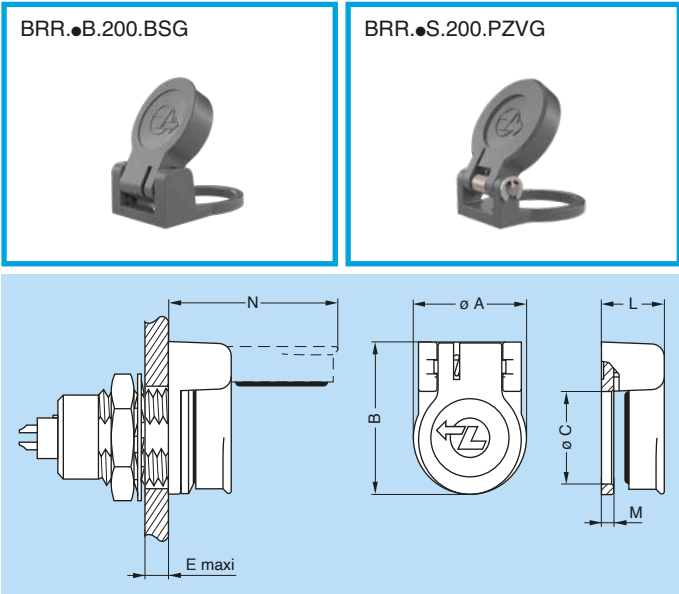

Part number	Series	Dimensions (mm)						
		A	B	C	E	L	M	N
BRR.0B.200.BSG	0B	11.0	14.8	9.0	5.8	6.1	1.2	16.5
BRR.1B.200.BSG	1B	14.6	19.2	12.0	6.0	7.7	1.6	21.2
BRR.2S.200.PZVG	2B	18.6	22.4	15.2	6.5	8.2	2.0	26.2
BRR.3S.200.PZVG	3B	22.5	26.5	18.2	9.0	8.8	2.5	30.8

Note: The cap comes standard in grey. A black version is also available, for this replace the last letter «G» of the part number by «N».

- Body material: POM (0B/1B)
- Gasket material: Silicone (0B/1B)
- Spring material: Stainless steel
- Axes material: Nickel-plated brass
- Maximum operating temperature: 100°C
- Watertightness: IP50 according to IEC 60529

BRR Spring loaded dust cap for ED sockets and EB sockets

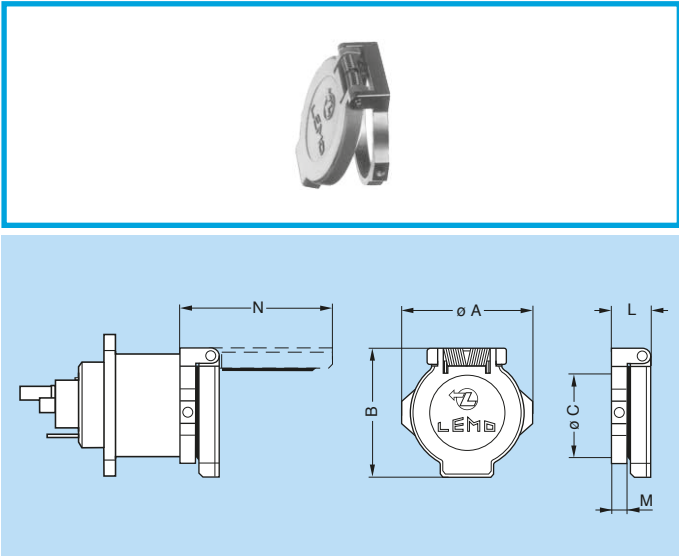

Part number	Series	Dimensions (mm)					
		A	B	C	L	M	N
BRR.3K.200.PZSG	3K	29	29	23	8.1	3	33.2

Note: Use Allen key (0.9 mm flat) to secure cap on connector.

- Cap material: Polyoxymethylene (POM) grey
- Body material: Nickel-plated brass
- Gasket material: Silicone rubber
- Spring material: Stainless steel
- Axes material: Nickel-plated brass
- Maximum operating temperature: 100°C
- Watertightness: IP61 according to IEC 60529

BFG Blanking caps for plugs (T series)

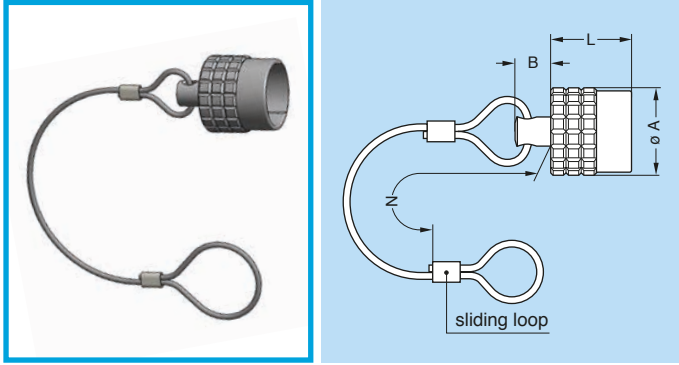

BHG Blanking caps for plugs (T series)

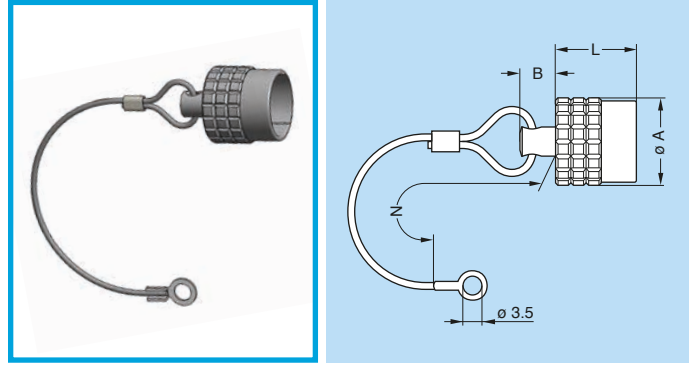

Part number	Dimensions (mm)				Part number
	A	B	L	N ¹⁾	
BFG.TT.100.CAS	7.0	4.3	9.0	60	BHG.TT.100.CAS
BFG.0T.100.CAS	9.5	5.0	11.0	85	BHG.0T.100.CAS
BFG.1T.100.CAS	12.0	6.3	12.4	85	BHG.1T.100.CAS
BFG.2T.100.CAS	15.0	6.4	13.8	85	BHG.2T.100.CAS
BFG.3T.100.CAS	18.8	6.4	17.6	120	BHG.3T.100.CAS

- Body material: Chrome-plated brass (Ni 3 µm)
- Lanyard material: Stainless steel
- Crimp ferrule material: Nickel-plated brass + polyolefin
- O-ring material: Silicone
- Operating temperature: -50°/135°C (Silicone rubber & Polyolefine)
- Watertightness: IP68 according to IEC 60529

Note: 1) the tolerance on this dimension is ± 5 mm.

BRF Blanking caps for free cable sockets (T series)

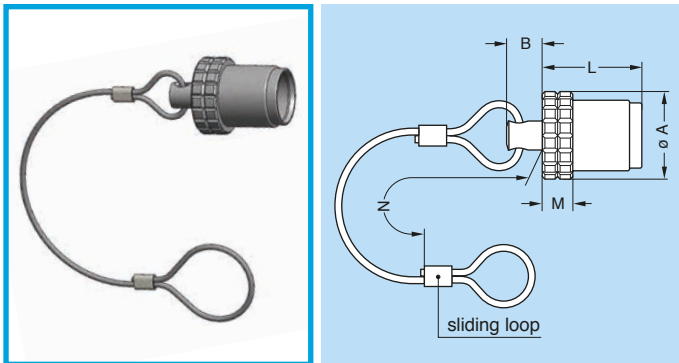

BRE Blanking caps for sockets (T series)

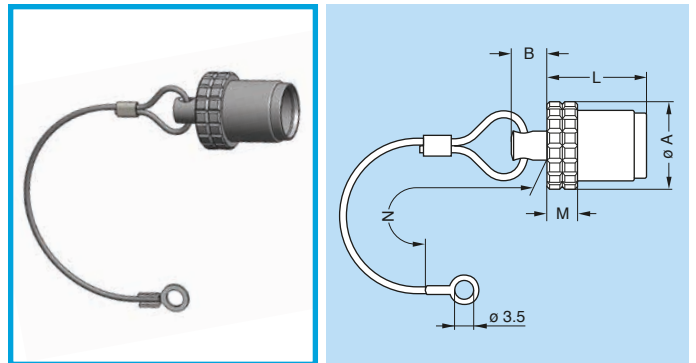

Part number	Dimensions (mm)					Part number
	A	B	L	M	N ¹⁾	
BRF.TT.200.CAZ	7.0	4.3	10.4	2.4	60	BRE.TT.200.CAZ
BRF.0T.200.CAZ	9.5	5.0	13.2	3.2	85	BRE.0T.200.CAZ
BRF.1T.200.CAZ	12.0	6.3	15.1	4.2	85	BRE.1T.200.CAZ
BRF.2T.200.CAZ	15.0	6.4	17.1	5.2	85	BRE.2T.200.CAZ
BRF.3T.200.CAZ	18.8	6.4	21.2	6.4	120	BRE.3T.200.CAZ

- Body material: Chrome-plated brass (Ni 3 µm)
- Lanyard material: Stainless steel
- Crimp ferrule material: Nickel-plated brass + polyolefin
- Operating temperature: -50°/135°C (Silicone rubber & Polyolefine)
- Watertightness: IP68 according to IEC 60529

Note: 1) the tolerance on this dimension is ± 5 mm.

GM Bend relief (TPU)

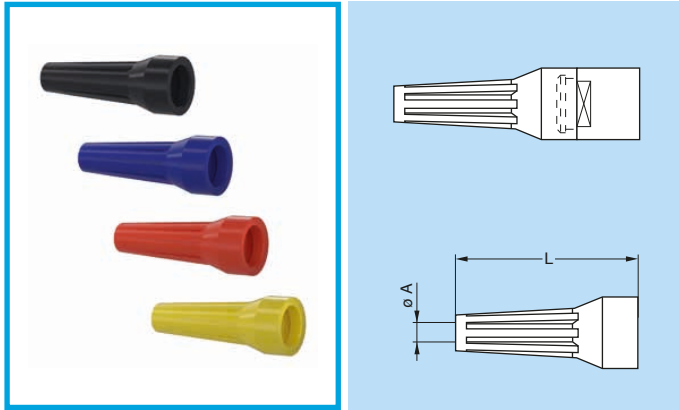

A bend relief made from thermoplastic polyurethane elastomer can be fitted over LEMO plugs and sockets that are supplied with nut for fitting such bend relief. They are available in nine different colours match with the GRA insulating washers (see page 109). Use the part numbers shown below to order this accessory separately.

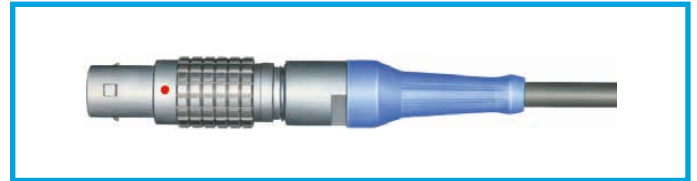

Main characteristics

- Material: TPU (Thermoplastic Polyurethane)
- Temperature range in dry atmosphere: -40°C +80°C

Part number	Series	Bend relief		Cable ø	
		A	L	min.	max.
GMA.00.012.DG ¹⁾	00-TT	1.2	22	1.1	1.4
GMA.00.018.DG ¹⁾		1.8	22	1.8	2.1
GMB.00.025.DG ¹⁾		2.5	22	2.5	2.8
GMB.00.028.DG ¹⁾		2.8	22	2.8	3.1
GMB.00.032.DG ¹⁾		3.2	22	3.2	3.5
GMD.00.025.DG ¹⁾		2.5	22	2.5	2.8
GMD.00.028.DG ¹⁾		2.8	22	2.8	3.1
GMD.00.032.DG ¹⁾		3.2	22	3.2	3.5
GMA.0B.025.DG		0B-0K-0T	2.5	24	2.5
GMA.0B.030.DG	3.0		24	3.0	3.4
GMA.0B.035.DG	3.5		24	3.5	3.9
GMA.0B.040.DG ¹⁾	4.0		24	4.0	4.4
GMA.0B.045.DG ¹⁾	4.5		24	4.5	5.2
GMA.1B.025.DG	1B-1K-1T XB	2.5	30	2.5	2.9
GMA.1B.030.DG		3.0	30	3.0	3.4
GMA.1B.035.DG		3.5	30	3.5	3.9
GMA.1B.040.DG		4.0	30	4.0	4.4
GMA.1B.045.DG		4.5	30	4.5	4.9
GMA.1B.054.DG		5.4	30	5.4	6.0
GMA.1B.065.DG ¹⁾		6.5	30	6.5	7.0

Part number	Series	Bend relief		Cable ø	
		A	L	min.	max.
GMA.2B.040.DG	2B-2K-2T	4.0	36	4.0	4.5
GMA.2B.045.DG		4.5	36	4.5	5.0
GMA.2B.050.DG		5.0	36	5.0	5.5
GMA.2B.060.DG		6.0	36	6.0	6.5
GMA.2B.070.DG		7.0	36	7.0	7.7
GMA.2B.080.DG ¹⁾		7.8	36	7.8	8.8
GMA.3B.050.DG ¹⁾	3B-3K-3T	4.5	42	4.5	5.2
GMA.3B.060.DG		6.0	42	6.0	6.9
GMA.3B.070.DG		7.0	42	7.0	7.9
GMA.3B.080.DG		8.0	42	8.0	8.9
GMA.3B.090.DG	9.0	42	9.0	10.0	
GMA.4B.080.DG ¹⁾	4B-4K 5B-5K	8.0	60	8.0	9.0
GMA.4B.010.DG ¹⁾		10.0	60	10.0	10.9
GMA.4B.011.DG ¹⁾		11.0	60	11.0	11.9
GMA.4B.012.DG ¹⁾		12.0	60	12.0	13.0
GMA.4B.013.DG ¹⁾	13.5	60	13.5	14.5	

Note: all dimensions are in millimetres.

- Standard
- Special

Note: ¹⁾ Design may differ from other bend relief, model without stripes. The «GMD» are thin bend reliefs (for very flexible cables). The last letter «G» of the part number indicates the grey colour of the bend relief. For ordering a bend relief with another colour, see table on page 106 and replace the letter «G» by the letter of the required colour. See also detailed information for each series on page 84.

GMA Bend relief (Silicone)

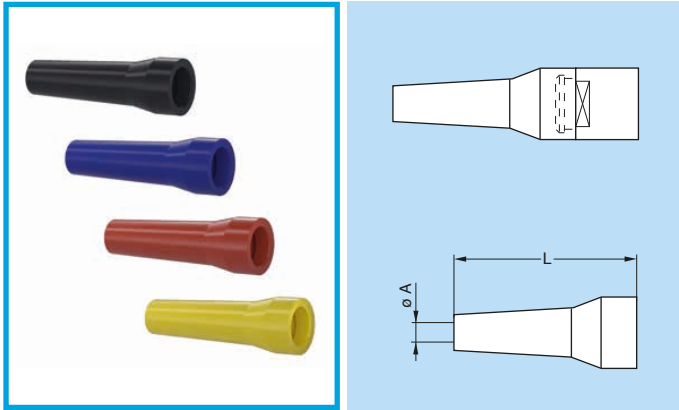

A bend relief has been designed for connectors used in applications at high temperature or requiring vapour sterilization.

These bend reliefs are different from previous ones as for their material, a silicone elastomer which is noted for its retention of flexibility over a wide temperature range. They are available in nine colours.

Use the part numbers shown below to order this accessory separately.

Main characteristics

- Material: Silicone elastomer VMQ
- Temperature range in dry atmosphere: -60°C +200°C
- Temperature range in water steam: +140°C

Part number	Series	Bend relief		Cable ø	
		A	L	min.	max.
GMA.0B.018.RG	0B-0K-0T	1.7	27	1.7	2.4
GMA.0B.025.RG		2.5	27	2.5	2.9
GMA.0B.030.RG		3.0	27	3.0	3.4
GMA.0B.035.RG		3.5	27	3.5	3.9
GMA.0B.040.RG		4.0	27	4.0	4.4
GMA.0B.045.RG		4.5	27	4.5	5.2
GMA.1B.025.RG	1B-1K-1T	2.5	34	2.5	2.9
GMA.1B.030.RG		3.0	34	3.0	3.4
GMA.1B.035.RG		3.5	34	3.5	3.9
GMA.1B.040.RG		4.0	34	4.0	4.4
GMA.1B.045.RG		4.5	34	4.5	5.0
GMA.1B.051.RG		5.1	34	5.1	5.6
GMA.1B.057.RG		5.7	34	5.7	6.2
GMA.1B.063.RG		6.3	34	6.3	7.0

Part number	Series	Bend relief		Cable ø	
		A	L	min.	max.
GMA.2B.040.RG	2B-2K-2T	4.0	41	4.0	4.4
GMA.2B.045.RG		4.5	41	4.5	5.0
GMA.2B.051.RG		5.1	41	5.1	5.6
GMA.2B.057.RG		5.7	41	5.7	6.2
GMA.2B.063.RG		6.3	41	6.3	7.0
GMA.2B.071.RG		7.1	41	7.1	7.9
GMA.2B.080.RG		8.0	41	8.0	9.0

Note: The last letter «G» of the part number indicates the grey colour of the bend relief. For ordering a bend relief with another colour, see table below and replace the letter «G» by the letter of the required colour. See also detailed information for each series on page 84.

Note: the selection of pigments, which should remain stable at high temperature, is limited by the new regulations. For this reason, some colours will be a shade different from those used for Thermoplastic Polyurethane (TPU) bend reliefs. The selected solutions represent the best possible compromise.

Ref.	Colour	Ref.	Colour	Ref.	Colour
A	blue	J	yellow	R	red
B	white	M	brown	S	orange
G	grey	N	black	V	green

GM Overall bend relief for plugs and free cable sockets

Overall bend reliefs, type GMF for plugs and GMP for free cable sockets offer optimum protection against mechanical damage and give a protection index of IP65 according to IEC 60529 (mated position). These bend reliefs slide easily over the connector shell and are positioned by slightly pressing the bend relief backnut. The special design of the bend relief for plug provides for easy use of the push-pull self-latching system.

GMF Bend relief for straight plug

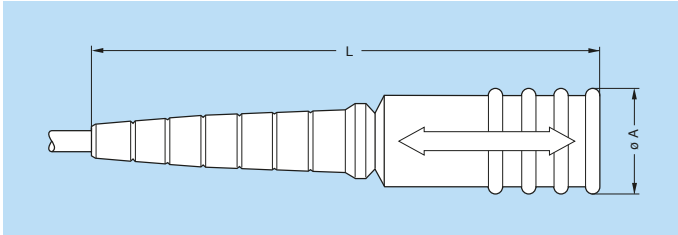

Part number	Series	Bend relief		Cable \varnothing	
		A	L	min.	max.
GMF.0B.035.060EN	0B-0T	11.0	60.5	1.0	3.5
GMF.1B.062.072EN	1B-1T	16.0	72.0	2.5	6.2
GMF.2B.082.095EN	2B-2T	22.0	95.0	5.0	8.2

- Material: Elastomer rubber black colour
- Operating temperature: -30°C to +120°C

GMP Bend relief for free cable socket

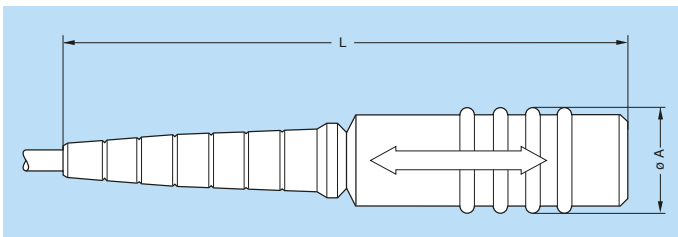

Part number	Series	Bend relief		Cable \varnothing	
		A	L	min.	max.
GMP.0B.035.069EN	0B-0T	11.0	69.0	1.0	3.5
GMP.1B.062.079EN	1B-1T	16.0	80.0	2.5	6.2
GMP.2B.082.102EN	2B-2T	21.0	102.5	5.0	8.2

- Material: Elastomer rubber black colour
- Operating temperature: -30°C to +120°C

- The overall bend relief shall be installed over plug or free cable socket fitted with a nut for bend relief.
- The typical applications are shown below.
- The overall bend relief can be cut at different length depending on cable diameter.

Plug - free cable socket

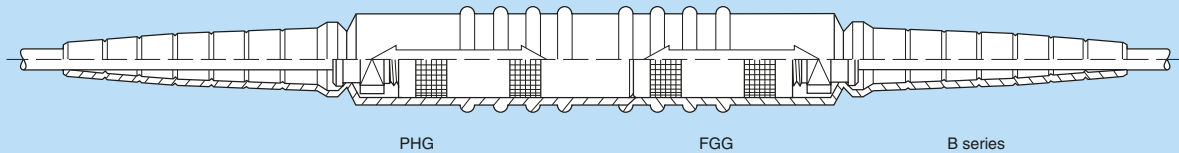

Plug - fixed cable socket

Optimum protection is offered only when using front panel mounting fixed cable sockets

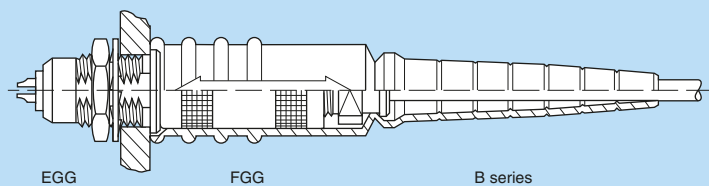

GMF Bend relief with cap for plug

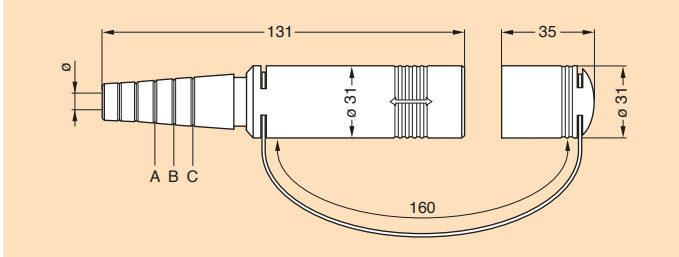

Part number	Series	For models	Cut	admissible \varnothing (mm)	
				min.	max.
GMF.4K.080.EANZ	4K	FGG	A	11.5	12.9
			B	13.0	14.9
			C	15.0	16.5

● Material: Black EPDM

GMP Bend relief with cap for free cable socket

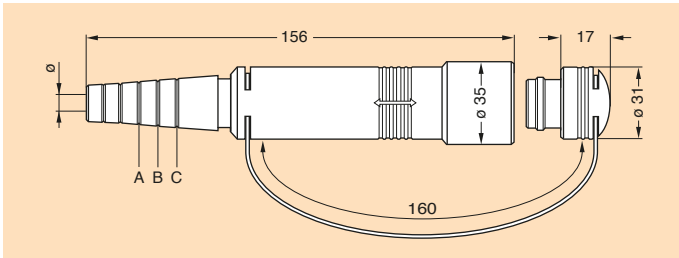

Part number	Series	For models	Cut	admissible \varnothing (mm)	
				min.	max.
GMP.4K.080.EANZ	4K	PHG	A	11.5	12.9
			B	13.0	14.9
			C	15.0	16.5

● Material: Black EPDM

GSC Lead-through with cable collet

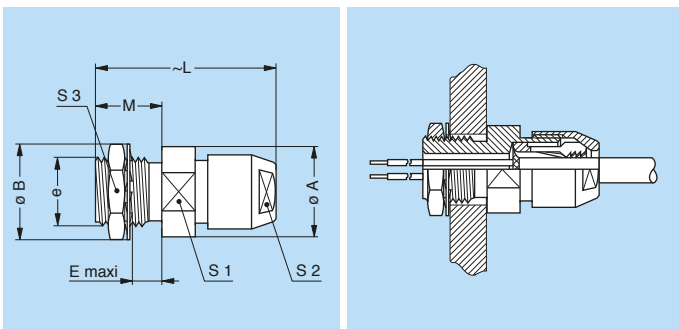

Part number	Dimensions (mm)								
	A	B	e	E	L	M	S1	S2	S3
GSC.00.290.CD●●	6.5	8.1	M5x0.5	1.5	16	4.0	5	6	7
GSC.1S.290.ND●●	12.0	12.5	M9x0.6	5.0	26	7.5	11	9	11
GSC.3S.290.ND●●	17.0	19.5	M15x1.0	8.1	30	12.0	-	14	17

Note: ●● = collet cable diameter of the B series. For cable diameter refer to page 80. Other surface treatment available.
The cable collet system stands for both screened and unscreened cables. It can be delivered with a nut for fitting a bend relief if you add a «Z» at the end of the part number.

GCA Earthing washer

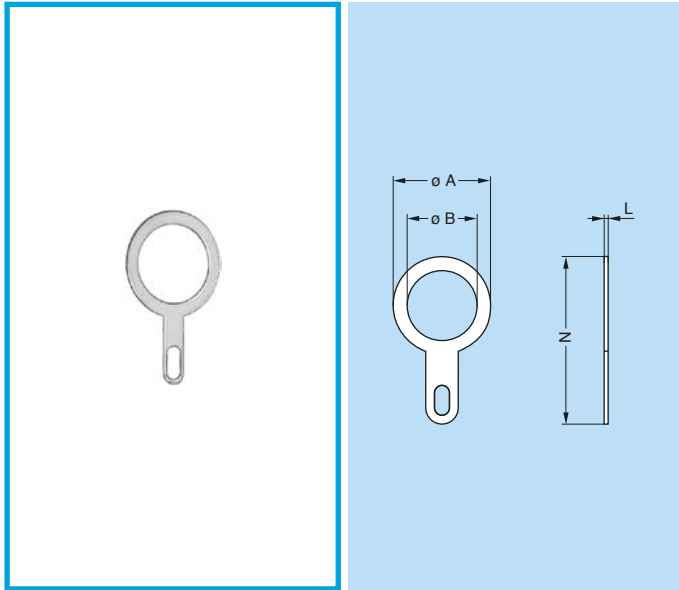

Part number	Series	Dimensions (mm)			
		A	B	L	N
GCA.00.255.LT	00-TT	9.5	7.1	0.4	18.2
GCA.0S.255.LT	0B-0T	13.0	9.1	0.4	22.0
GCA.0E.255.LT	0K	17.0	14.1	0.5	27.5
GCA.1S.255.LT	1B-1T	17.0	12.2	0.5	27.5
GCA.1E.255.LT	1K	20.0	16.2	0.5	32.0
GCA.2S.255.LT	2B-2T	20.0	15.2	0.5	32.0
GCA.2E.255.LT	2K	25.0	20.2	0.5	39.0
GCA.3S.255.LT	3B-3T	25.0	18.2	0.5	39.0
GCA.3E.255.LT	3K	31.0	24.0	0.5	43.0
GCA.4S.255.LT	4B	35.0	25.6	0.6	50.0
GCA.4E.255.LT	4K	35.0	30.6	0.6	50.0
GCA.5S.255.LT	5B	42.0	35.1	0.3	57.5

● Material: CuSnZn plated brass (2 μ m)

● Standard ● Special

GRA Insulating washers

Sockets or plugs mounted on panels can be fitted with insulating washers. The nine colours available combined with those for the bend reliefs makes colour coding possible.

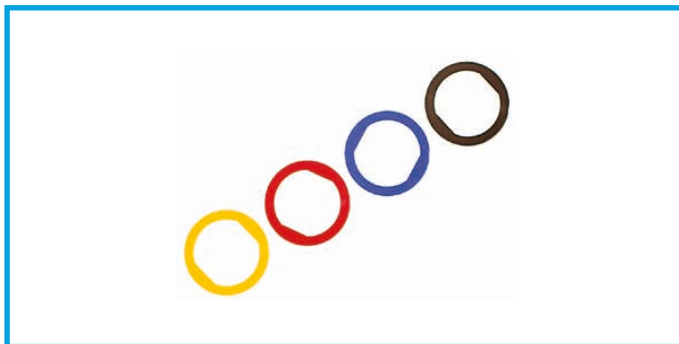

Part number	Series	Dimensions (mm)						
		A	B	E	L	M	S	T
GRA.00.269.GG	00	10.0	8.8	4.5	1.8	1.0	6.4	8.0
GRA.0S.269.GG	0B	12.0	10.8	6.0	1.8	1.0	8.3	9.9
GRA.1S.269.GG	1B	16.0	13.8	6.5	1.8	1.0	10.6	12.2
GRA.2S.269.GG	2B	21.1	17.9	7.3	2.3	1.3	13.6	16.2
GRA.3S.269.GG	3B	25.0	21.8	10.3	2.2	1.2	16.7	20.2
GRA.4S.269.GG	4B	31.9	28.7	10.5	2.5	1.5	23.6	27.1

● Standard ● Special

Note: insulating washers for series 5B are available on request.

Caution: these insulating washers can be used with fixed and free sockets with across flat dimension S1 equivalent to the S dimension of the washer.

● Material: Polyamide
● Maximum operating temperature: 90°C

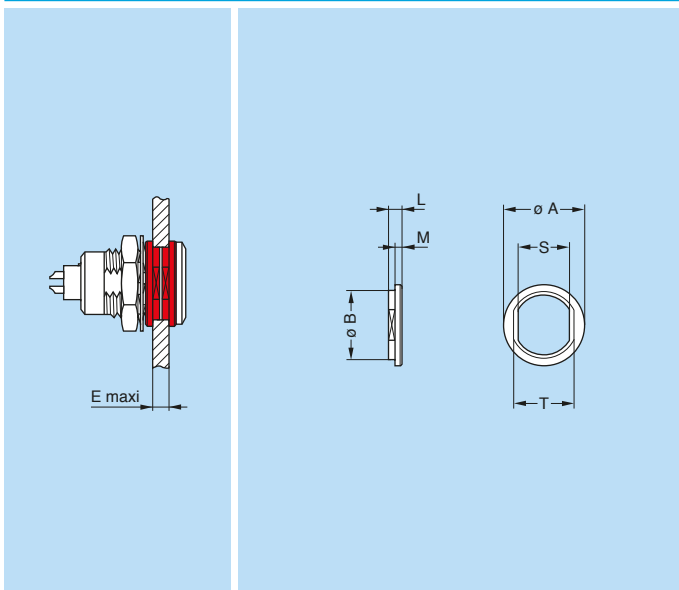

Ref.	Colour	Ref.	Colour	Ref.	Colour
A	blue	J	yellow	R	red
B	white	M	brown	S	orange
G	grey	N	black	V	green

Note: the last letter «G» of the part number indicates the colour grey for the insulating washer. To obtain an insulating washer of another colour, refer to the table above and change the letter «G» of the part number to the corresponding letter of the colour required. For the panel cut-out, please consult chapter «Panel cut-out» on page 118.

GRC Double panel washers

Double panel washers have been designed to make the drilling of panel holes easier for mounting fixed and free sockets. The combination of the nine different colours of the double panel washers and of the bend reliefs makes colour coding possible.

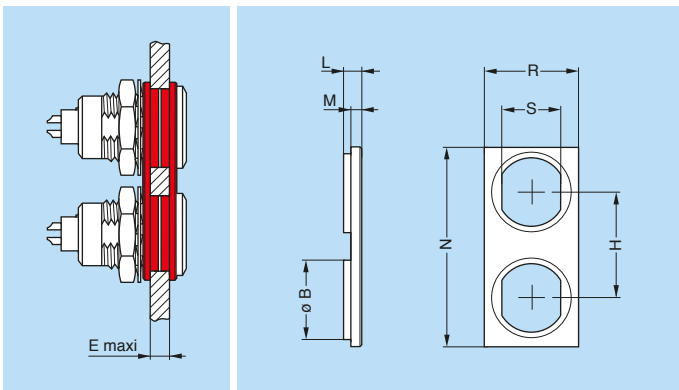

Part number	Series	Dimensions (mm)							
		B	E	H	L	M	N	R	S
GRC.0S.260.HG	0B	10.9	5	14	2.5	1.5	26.5	12.5	8.3
GRC.1B.260.HG	1B	13.9	5	20	3.3	1.8	34.5	14.5	10.6

Caution: these double panel washers can be used with fixed or free sockets with across flat dimension S1 equivalent to the S dimension of the washer.

- Material: Polyamide
- Maximum operating temperature: 90°C

Ref.	Colour	Ref.	Colour	Ref.	Colour
A	blue	J	yellow	R	red
B	white	M	brown	S	orange
G	grey	N	black	V	green

Note: the last letter «G» of the washer's part number indicates the colour grey. For other colours, refer to the above table and replace letter «G» by the one corresponding to the colour required. For the panel cut-out, please consult chapter «Panel cut-out» on page 118.

Tooling

DCG Spanners for hexagonal nuts

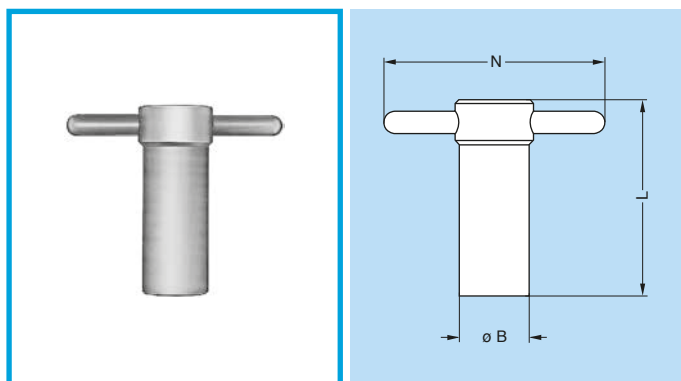

Part number	Dimensions (mm)			Part number of the nut (page 94)
	B	L	N	
DCG.91.149.0TN	14	40	50	GEA.00.240.LN
DCG.91.161.1TN	16	45	52	GEA.0S.240.LN
DCG.91.201.4TN	20	52	65	GEA.1S.240.LN
DCG.91.231.7TN	23	62	68	GEA.2S.240.LN
DCG.91.282.2TN	28	76	73	GEA.3S.240.LN

● Material: blackened steel

DCA Spanners for hexagonal nuts with locator for flats on socket thread

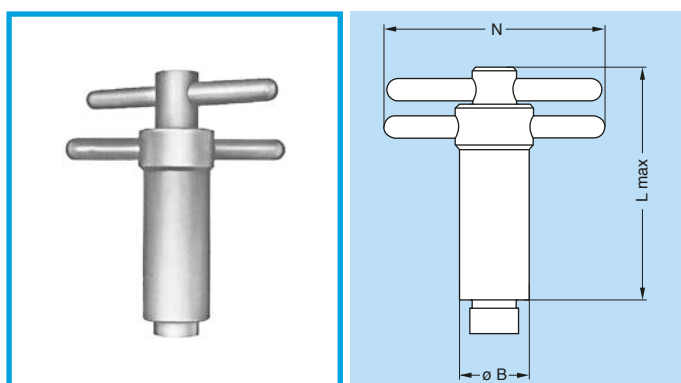

Part number	Dimensions (mm)			Part number of the nut (page 94)
	B	L	N	
DCA.91.149.0TN	14	65	50	GEA.00.240.LN
DCA.91.161.1TN	16	73	52	GEA.0S.240.LN
DCA.91.201.4TN	20	85	65	GEA.1S.240.LN
DCA.91.231.7TN	23	100	68	GEA.2S.240.LN
DCA.91.282.2TN	28	120	73	GEA.3S.240.LN

● Material: blackened steel

DCB Spanners for round nuts

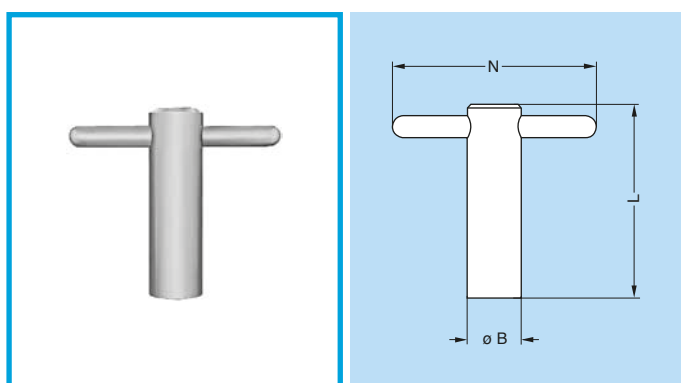

Part number	Dimensions (mm)			Part number of the nut (page 95)
	B	L	N	
DCB.91.119.0TN	11	40	50	GEB.00.240.LN
DCB.91.131.1TN	13	45	50	GEB.0S.240.LN
DCB.91.161.4TN	16	52	65	GEB.1S.240.LN
DCB.91.201.8TN	20	62	65	GEB.2S.240.LN
DCB.91.242.2TN	24	76	70	GEB.3S.240.LN

● Material: blackened steel

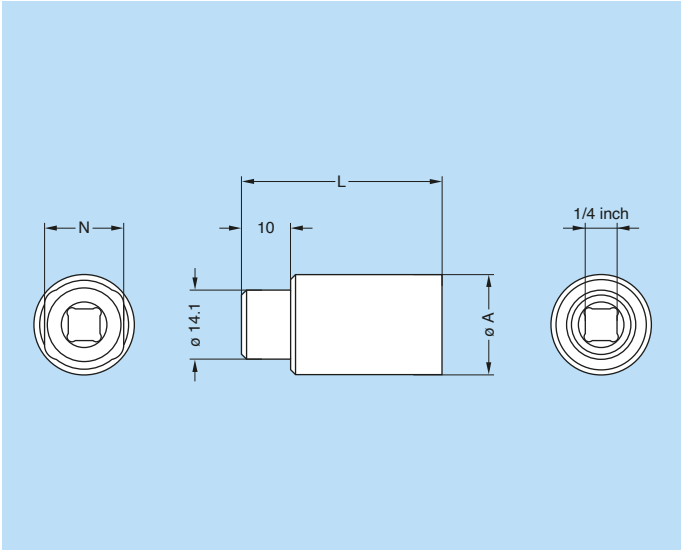
DCM Insert conicals nut tightening tools

Part number	Dimensions (mm)			Part number of the nut (page 95)
	A	L	N	
DCM.65.080.AZ	12.4	33.0	8.1	GEC.00.240.LC
DCM.65.100.AZ	14.4	33.0	10.1	GEC.0S.240.LC
DCM.65.120.AZ	16.4	33.0	12.1	GEC.1S.242.LC
DCM.65.130.AZ	18.1	33.0	13.1	GEC.1S.240.LC
DCM.65.160.AZ	20.4	41.0	16.1	GEC.0E.240.LC
DCM.65.170.AZ	22.4	41.0	17.1	GEC.1S.241.LC
				GEC.2S.240.LC
DCM.65.200.AZ	26.4	41.0	20.1	GEC.2S.241.LC
				GEC.3S.240.LC
				GEC.2E.240.LC
DCM.65.220.AZ	27.4	41.0	22.1	GEC.2E.240.LC
DCM.65.270.AZ	32.6	46.0	27.1	GEC.3E.240.LC
				GEC.4S.240.LC
DCM.65.320.AZ	38.1	46.0	32.1	GEC.4K.241.LC
DCM.65.370.AZ	43.1	47.0	37.1	GEC.5S.240.LC

Note: for standard 1/4 inch tools adaptor.

● Standard ● Special

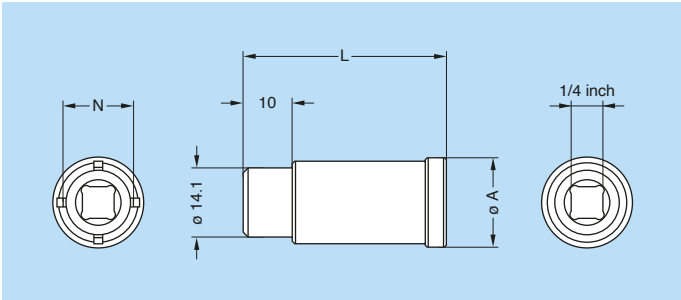
DCM Insert notched nuts tightening tools

Part number	Dimensions (mm)			Part number of the nut (page 94)
	A	L	N	
DCM.65.088.AZ4	13.0	33.5	8.9	GEG.00.240.LC
DCM.65.106.AZ4	15.0	34.3	10.8	GEG.0S.240.LC
DCM.65.122.AZ4	17.0	33.3	12.3	GEG.1S.242.LC
DCM.65.141.AZ4	18.4	41.5	14.2	GEG.1S.240.LC
DCM.65.159.AZ4	20.4	41.5	16.1	GEG.0E.240.LC
DCM.65.176.AZ6	22.4	41.5	17.9	GEG.2S.240.LC
				GEG.1E.240.LC
DCM.65.205.AZ6	25.5	41.5	21.2	GEG.2S.241.LC
DCM.65.225.AZ6	26.5	41.5	22.8	GEG.2E.240.LC

Note: for standard 1/4 inch tools adaptor.

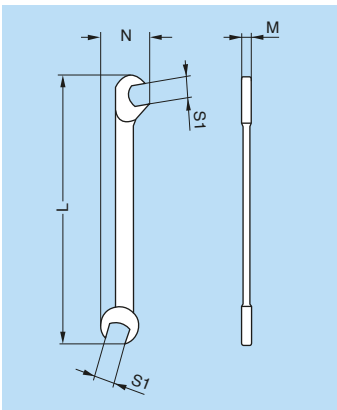
DCP Flat spanners for collet nut

Part number	Dimensions (mm)			
	L	M	N	S1
DCP.99.040.TC	70	0.95	10.5	4.0
DCP.99.045.TC	70	2.00	10.5	4.5
DCP.99.050.TC	78	2.00	12.6	5.0
DCP.99.055.TC	78	2.00	12.6	5.5
DCP.99.060.TC	78	2.00	12.6	6.0

● Material: chrome-plated steel

DCP Set of flat spanners for collet nuts

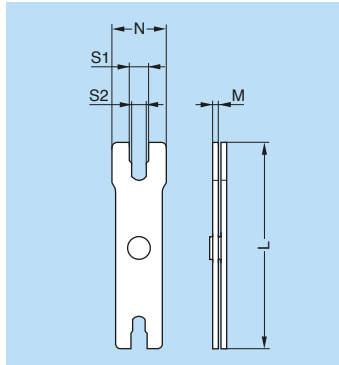

Part number	Series	Dimensions (mm)				
		L	M	N	S1	S2
DCP.91.001.TN	0B-0K	95	2.5	21	8.1	7.1
	1B-1K	95	2.5	25	10.1	9.1
DCP.91.023.TN	2B-2K	115	3.0	30	13.1	12.1
	3B-3K	115	3.0	35	15.1	14.1
DCP.91.045.TN	4B	130	3.0	44	21.1	20.1
	5B	130	3.0	54	31.1	30.1

● Material: blackened steel

● Standard ● Special

DCP Set of flat spanners for collet nuts

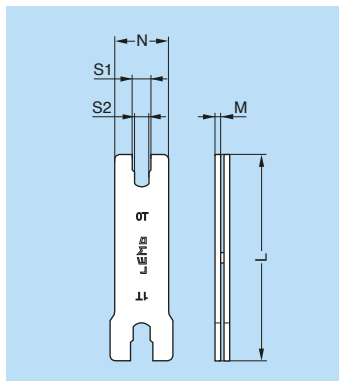
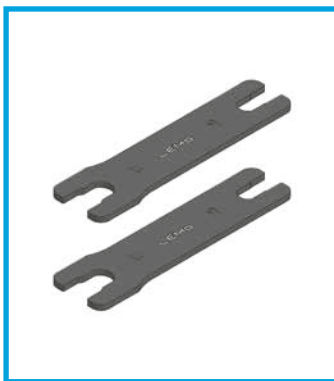

Part number	Series	Dimensions (mm)				
		L	M	N	S1	S2
DCP.0T.110.TN	0T	95	2.5	21	7.55	7.05
	1T	95	2.5	25	11.05	9.05
DCP.2T.110.TN	2T	115	3.0	30	14.05	12.05
	3T	115	3.0	35	16.05	14.05

● Material: blackened steel

DCP Set of flat spanners for FS● retaining ring & collet nuts

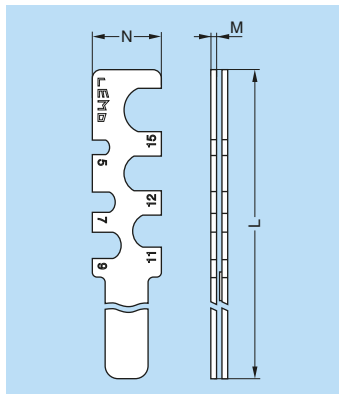

Part number	Series	Dimensions (mm)		
		L	M	N
DCP.91.FSG.TN	00-0B-1B-2B	152	2	24
DCP.91.FSG.TN3B	3B	153	2	32

● Material: blackened steel

DCP Set of flat spanners for FS● retaining ring & collet nuts

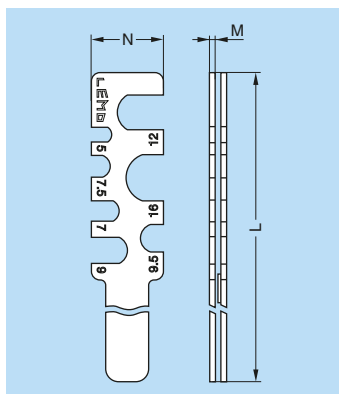

Part number	Series	Dimensions (mm)		
		L	M	N
DCP.TT.FSG.TN	TT-0T-1T-2T	152	2	25

● Material: blackened steel

DCN Spanners for assembling plugs with 3 latches

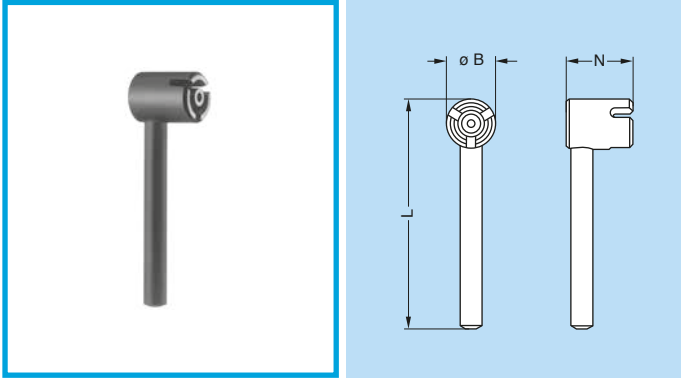

Part number	Series	Dimensions (mm)		
		B	L	N
DCN.91.905.0TK	00	9	42	12

● Material: blackened steel

DCL Assembly tool for FVB.00.303.NLA plugs

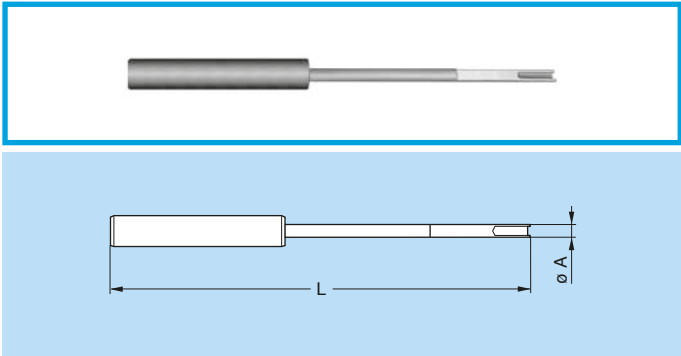

Part number	Series	Dim. (mm)	
		A	L
DCL.91.516.5TK	00	5	165

DTA Taps

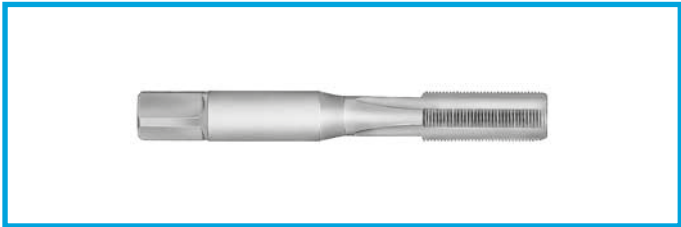

Part number	Series	Thread
DTA.99.700.5Z	00	M7 x 0.5
DTA.99.900.6Z	0B	M9 x 0.6

DPF Pliers for assembling plugs (K series)

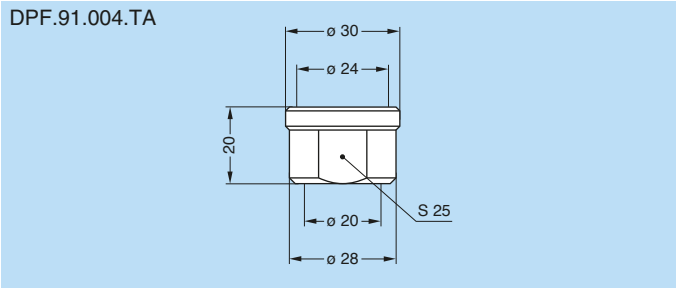
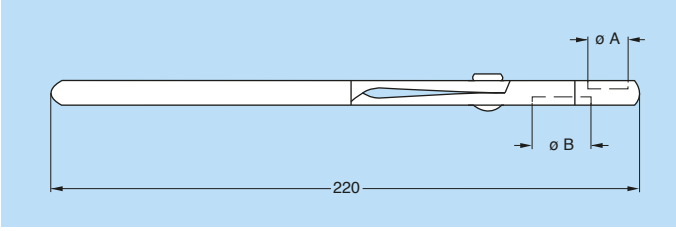

Part number	Series	Dim. (mm)	
		A	B
DPF.91.001.TA	0K	10	–
	1K	–	12
DPF.91.023.TA	2K	15	–
	3K	–	18
DPF.91.004.TA	4K	–	–

● Standard ● Special

Example for use

The plug end must be held in the pliers whilst the nut is tightened with the flat spanner.

Using tool DPF.91.004.TA to retain the plug nose (4K) in the bench wrench.

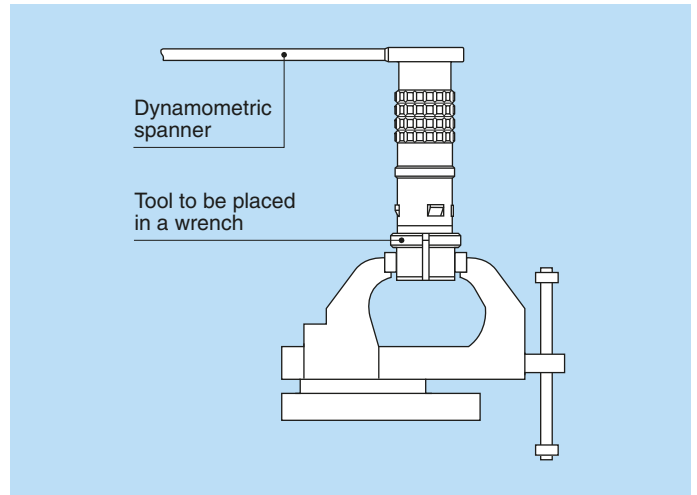
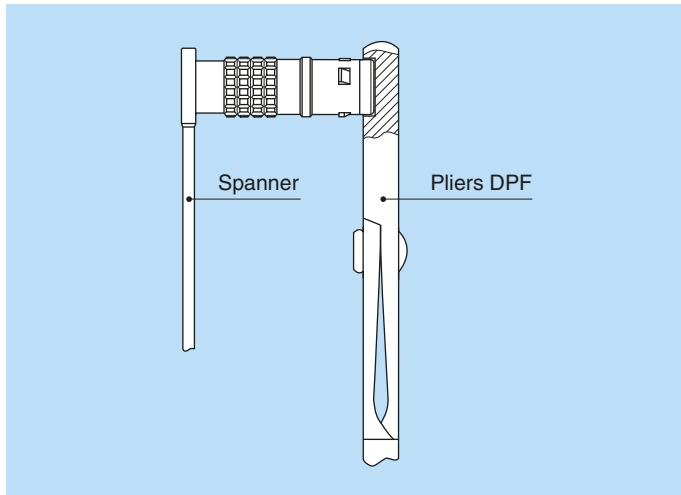

Panel cut-outs

B and T series

P1-P3-P4-P5

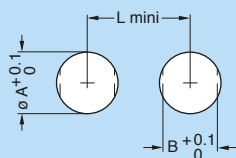

P2-P6

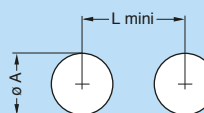

Series	P1			P2		P3			P4			P5			P6	
	$\varnothing A^1$	B	L	$\varnothing A$	L	$\varnothing A$	B	L	$\varnothing A$	B	L	$\varnothing A$	B	L	$\varnothing A$	L
00-TT	7.1	6.4	12.5	7.1	11.5	-	-	-	-	-	-	7.1	-	12	-	-
0B-0T	9.1	8.3	14.5	9.1	13.5	14.1	12.6	20.1	10.1	9.1	15.0	9.1	8.3	15	-	-
1B-1T	12.1	10.6	18.5	-	-	16.1	14.6	22.0	14.1	12.6	21.0	12.1	10.6	19	11.1	17
XB	14.1	12.6	21.5	-	-	-	-	-	-	-	-	-	-	-	-	-
2B-2T	15.1	13.6	22.5	-	-	19.2	17.1	28.0	16.1	15.1	23.0	15.1	13.6	23	-	-
3B-3T	18.2	16.6	27.0	-	-	-	-	-	20.2	18.6	29.5	18.2	16.6	27	-	-
4B	25.2	23.6	36.0	-	-	-	-	-	25.2	23.6	36.1	25.2	23.6	36	-	-
5B	35.2	33.6	44.0	-	-	-	-	-	35.2	33.6	47.1	35.2	33.6	47	-	-

Note: ¹) when using the tapered washer (GBB) a round hole apply 00-TT: \varnothing 7.6 mm / 0B-0T: \varnothing 9.6 mm / 1B-1T: \varnothing 12.6 mm / 2B-2T: \varnothing 15.7 mm / 3B-3T: \varnothing 18.8 mm / 4B: \varnothing 26 mm / 5B: \varnothing 36 mm (tolerance: 0/+0.02).

Cut-out types

Model	Type	Model	Type	Model	Type
EA●	P1	EX●	P2/P6 ²⁾	HN●	P5
EC●	P1	EY●	P1/P6 ²⁾	PE●	P1
EE●	P1	FA●	P1	PF●	P1
EG●	P1	FW●	P5	PK●	P1
EF●	P2	HC●	P3	R●●	P4
EH●	P1	HE●	P5	S●●	P4/P5 ³⁾
EN●	P1	HG●	P5	XB●	P2
ENY	P1	HH●	P5	XRB	P2
ES●	P2	HM●	P5	YH●	P5

Note: ²⁾ in series 1B use P6. ³⁾ in series 1B use P5.

Mounting nut torque

Series	Torque (Nm)	
	Metal shell	Plastic shell ⁴⁾
00-TT	1.0	0.4
0B-0T	2.5	0.4
1B-1T	4.5	0.7
XB	5.0	-
2B-2T	6.0	0.8
3B-3T	9.0	1.0
4B	12.0	5.0
5B	17.0	-

Note: ⁴⁾ these values apply when metal shell are mounted with insulating washer.

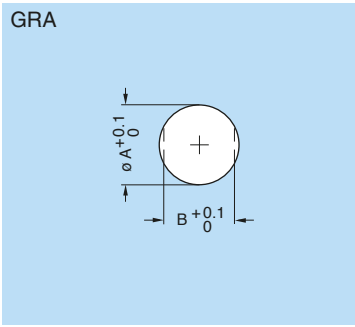
Panel cut-out for mounting with insulating washer (B series)

Series	Dim. (mm)	
	$\varnothing A$	B
00	8.9	8.1
0B	10.9	10.0
1B	13.9	12.3
2B	18.0	16.3
3B	21.9	20.3
4B	29.1	27.4

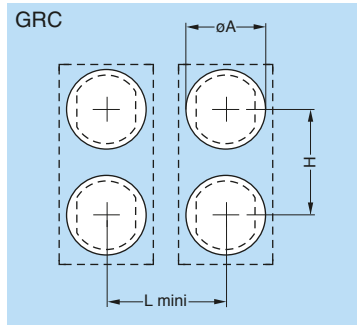
Panel cut-out for mounting with double panel washer (B series)

Series	Dimensions(mm)		
	$\varnothing A$	H	L
0B	11	14	13.5
1B	14	20	17.0

Note: for nut tightening torques please refer to the corresponding series in the table on page 117.

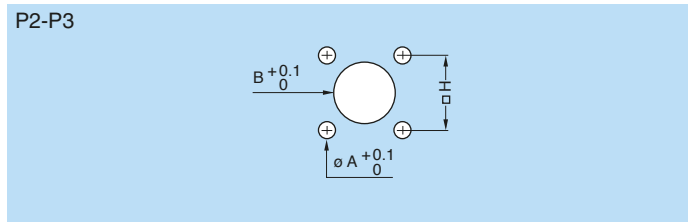
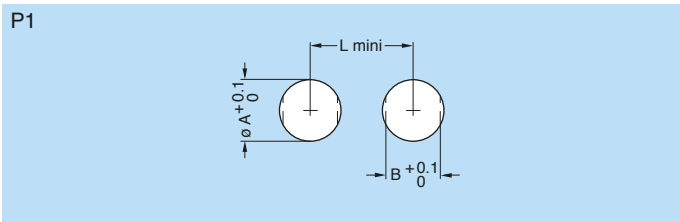
K series

Series	P1			P2			P3		
	$\varnothing A$	B	L	$\varnothing A$	B	H	$\varnothing A$	B	H
0K	14.1	12.6	20.5	-	-	-	-	-	-
1K	16.1	14.6	22.5	-	-	-	-	-	-
2K	20.2	18.6	29.0	-	-	-	-	-	-
3K	24.2	22.6	35.5	3.5	22.6	20.6	3.5	23.1	23.0
4K	30.2	28.6	43.0	3.5	28.6	27.0	3.5	30.1	29.0
5K	45.2	42.6	57.0	4.5	42.6	38.0	4.5	45.1	44.0

Cut-out types

Model	Type	Model	Type	Model	Type
EA●	P1	EN●	P1	PE●	P1
EB●	P3	FA●	P1	PK●	P1
ED●	P3 ¹⁾	FX●	P2	S●●	P1
EE●	P1	HE●	P1		
EG●	P1	HG●	P1		
EH●	P1	HM●	P1		

Note: ¹⁾ for this model dimension B = 18.1.

Mounting nut torque

Series	Torque (Nm)
0K	5
1K	7
2K	9
3K	12
4K	17
5K	22

1 N = 0.102 kg

PCB drilling pattern

Straight print contacts (for socket EZ●/EY●) P7

302

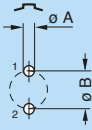

Series	Dimensions	
	A	B
0B	0.8	2.2
1B	0.8	2.8
2B	0.8	4.4

303

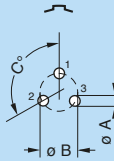

Series	Dimensions		
	A	B	C
0B	0.8	2.30	120°
1B	0.8	3.00	120°
2B	0.8	4.60	120°

304

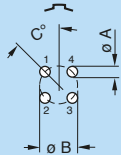

Series	Dimensions		
	A	B	C
0B	0.6	2.5	45°
1B	0.8	3.1	45°
2B	0.8	5.0	45°

305

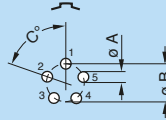

Series	Dimensions		
	A	B	C
0B	0.6	2.8	72°
1B	0.8	3.4	72°
2B	0.8	5.2	72°

306

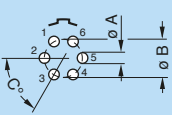

Series	Dimensions		
	A	B	C
0B	0.6	3.0	60°
1B	0.8	3.7	60°

306

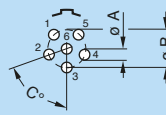

Series	Dimensions		
	A	B	C
2B	0.8	5.6	72°

307

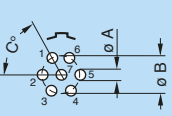

Series	Dimensions		
	A	B	C
0B	0.6	3.00	60°
1B	0.8	3.70	60°
2B	0.8	5.80	60°

308

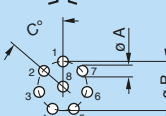

Series	Dimensions		
	A	B	C
1B	0.8	3.8	51°26'

308

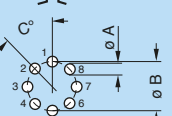

Series	Dimensions		
	A	B	C
2B	0.8	6.4	45°

309

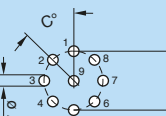

Series	Dimensions		
	A	B	C
0B	0.6	3.2	45°

310

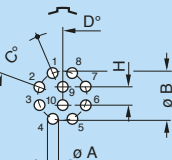

Series	Dimensions				
	A	B	C	D	H
1B	0.6	3.95	45°	22°30'	1.40
2B	0.8	6.30	45°	22°30'	2.15

312

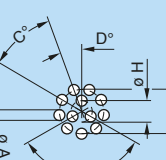

Series	Dimensions				
	A	B	C	D	H
0B	0.5	3.3	40°	20°	1.25

Note: contact numbering is for female contact version only.

PCB drilling pattern

Straight print contacts (for socket EZ●/EY●) P7

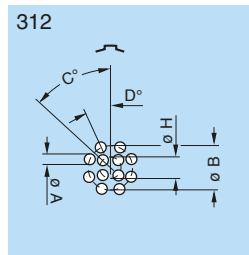

Series	Dimensions				
	A	B	C	D	H
2B	0.8	6.50	45°	22°30'	2.80

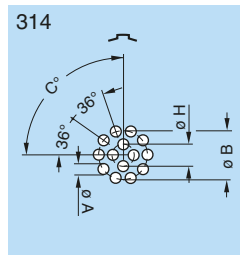

Series	Dimensions			
	A	B	C	H
1B	0.6	4.4	90°	1.90
2B	0.8	6.5	90°	2.65

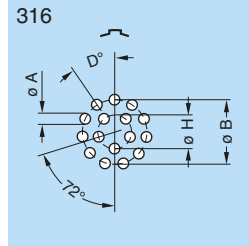

Series	Dimensions			
	A	B	D	H
1B	0.6	4.4	32°44'	2.00

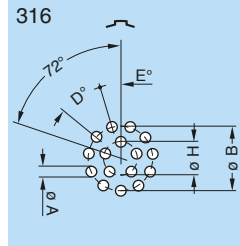

Series	Dimensions				
	A	B	D	E	H
2B	0.8	6.6	32°44'	16°22'	3.10

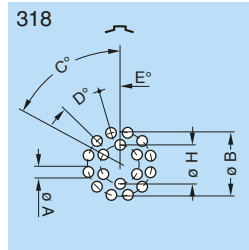

Series	Dimensions					
	A	B	C	D	E	H
2B	0.8	6.7	60°	30°	15°	3.50

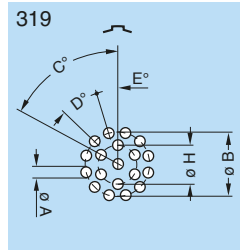

Series	Dimensions					
	A	B	C	D	E	H
2B	0.8	6.7	60°	30°	15°	3.5

Note: all views are from the side of the socket.

Length of straight print contacts (for socket EZ●/EY●)

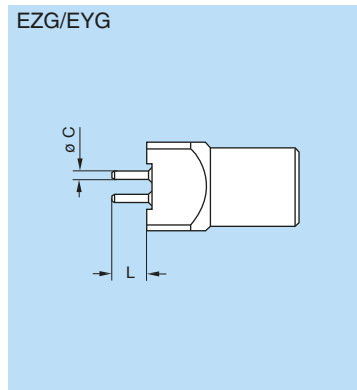

	Type	Models	
		EZ●/EY●	
		Ø C	L
0B	302/303	0.7	4.5
	304/305	0.5	4.5
	306/307/309/312	0.5	3.0
1B	302/303/304/305/306/307/308	0.7	3.8
	310/314/316	0.5	3.8
2B	302/303/304/305/306/307/308 310/312/314/316/318/319	0.7	5.5

Fixed socket for printed circuit (B series) P8

Holes for fixing the housing

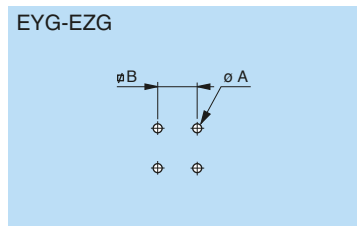

Series	Dimensions	
	A	B
00	0.8 ¹⁾	5.08
0B	1.7 ²⁾	7.62
1B	1.7 ²⁾	7.62
2B	1.7 ²⁾	10.16

Note: Mounting torque for screws: 0.1 Nm. ¹⁾ to solder. ²⁾ to screw.

Fixed socket with elbow print contact (B-K-T series) P9

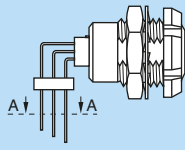

302

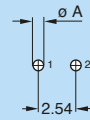

Series	Dim. A
00-TT	0.6
0B-0K-0T	0.7
1B-1K-1T	0.9
2B-2K-2T	0.9

303

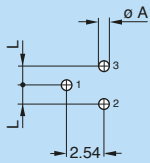

Series	Dimensions	
	A	L
00-TT	0.6	1.27
0B-0K-0T	0.7	1.27
1B-1K-1T	0.9	1.27
2B-2K-2T	0.9	2.54

304

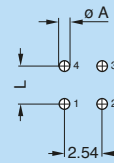

Series	Dimensions	
	A	L
00-TT	0.6	2.54
0B-0K-0T	0.7	2.54
1B-1K-1T	0.7	2.54
2B-2K-2T	0.9	3.50
3B-3K-3T	0.9	2.54

0B-0K-0T.305

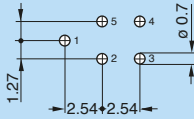

1B-1K-1T / 3B-3K-3T.305

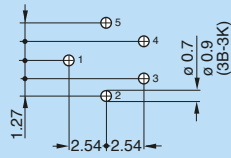

2B-2K-2T.305

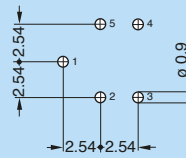

0B-0K-0T / 1B-1K-1T.306

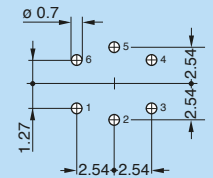

2B-2K-2T / 3B-3K-3T.306

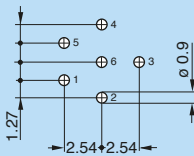

0B-0K-0T / 1B-1K-1T.307

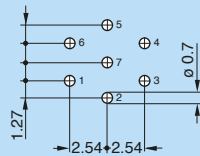

2B-2K-2T.307

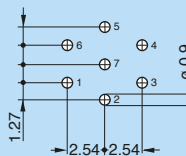

1B-1K-1T.308

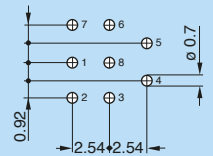

2B-2K-2T / 3B-3K-3T.308

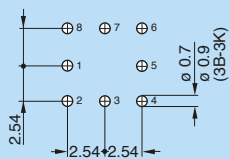

0B-0K-0T.309

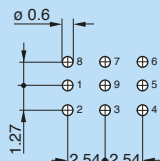

1B-1K-1T / 2B-2K-2T / 3B-3K-3T.310

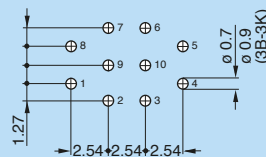

2B-2K-2T / 3B-3K-3T.312

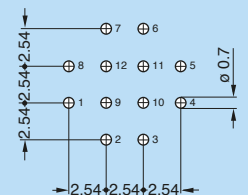

1B-1K-1T / 2B-2K-2T / 3B-3K-3T.314

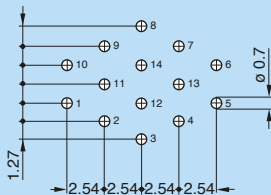

2B-2K-2T / 3B-3K-3T.316

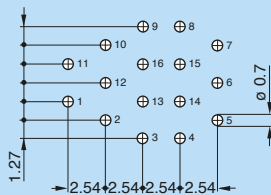

2B-2K-2T.318

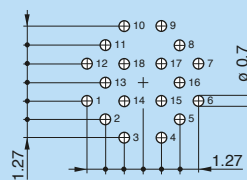

3B-3K-3T.318

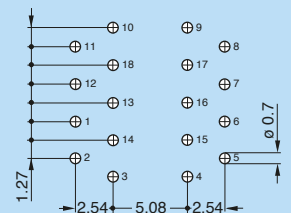

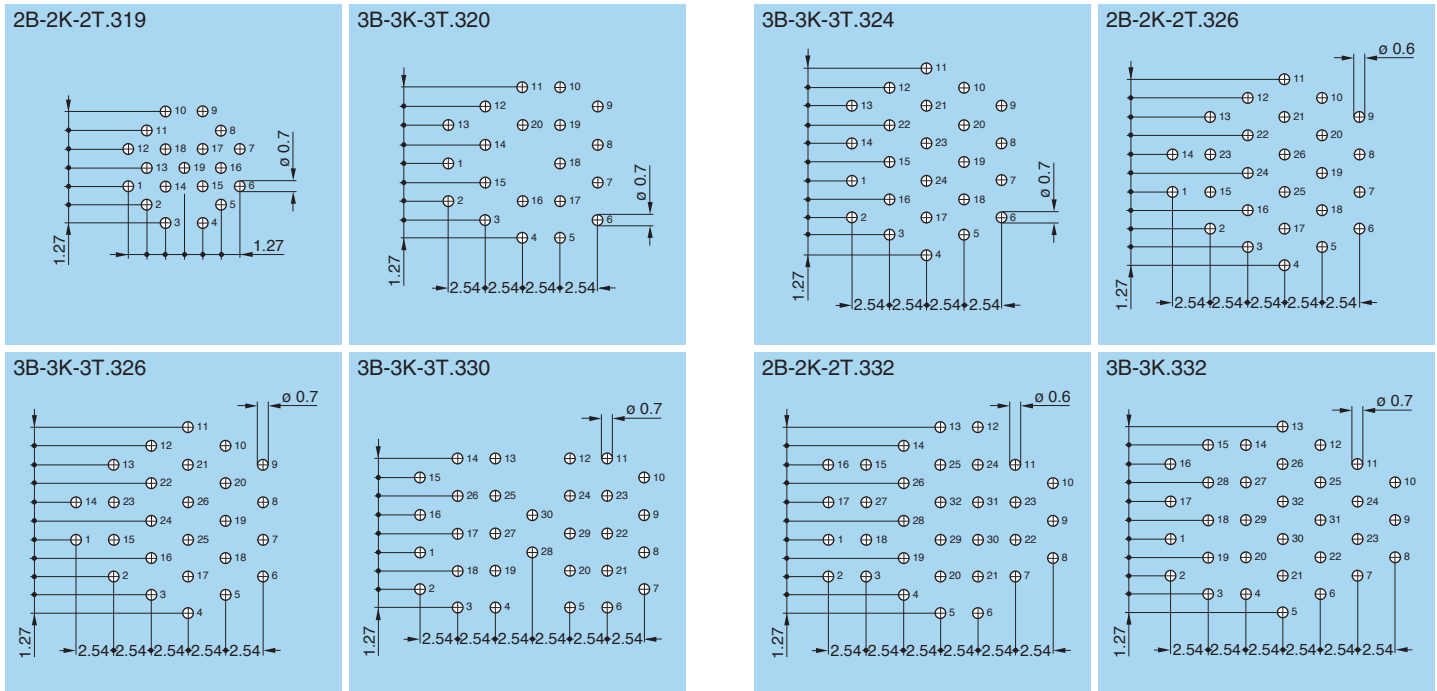
Fixed socket with elbow print contact (B-K-T series) P9

Note: contact numbering is for female contact version only.

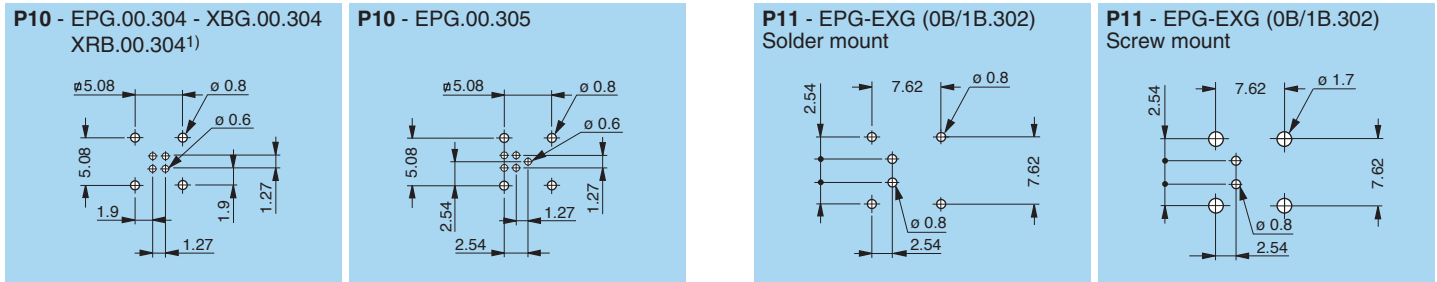
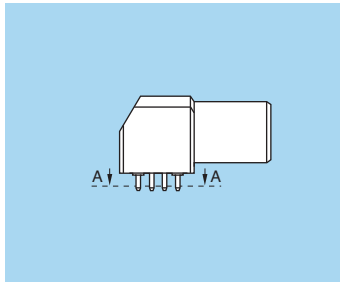
Elbow socket (90°) for printed circuit (B series) P10 P11

Note:
 1) for the XRB.00 series the holes for shell fixing are different (see page 34).
 2) the dimensions for the EPG.00.303.HLN and XBG.00.303.HLN models are given on pages 26 and 33. For other models please contact factory.

Elbow socket (90°) for printed circuit (B series) P11 P12

P11 - EPG-EXG (0B/1B.303)
Solder mount

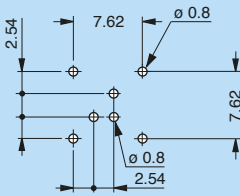

P11 - EPG-EXG (0B/1B.303)
Screw mount

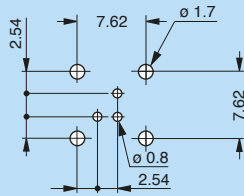

P11 - EPG-EXG (0B/1B.304)
Solder mount

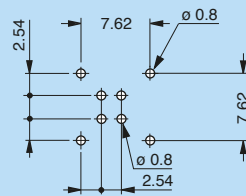

P11 - EPG-EXG (0B/1B.304)
Screw mount

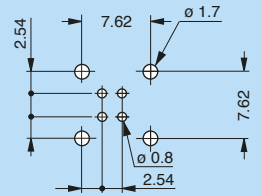

P11 - EPG-EXG (0B/1B.305)
Solder mount

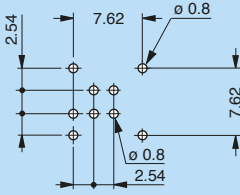

P11 - EPG-EXG (0B/1B.305)
Screw mount

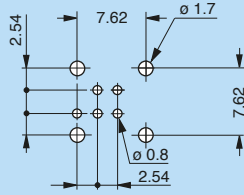

P11 - EPG-EXG (0B/1B.306)
Solder mount

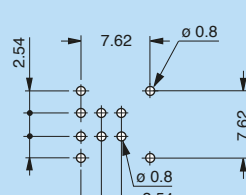

P11 - EPG-EXG (0B/1B.306)
Screw mount

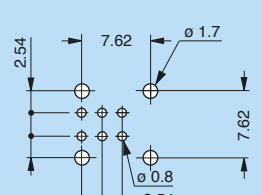

P11 - EPG-EXG (0B/1B.307)
Solder mount

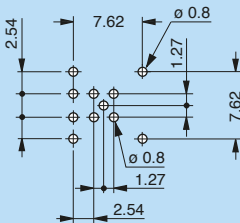

P11 - EPG-EXG (0B/1B.307)
Screw mount

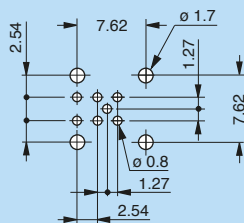

P11 - EPG-EXG (1B.308)
Solder mount

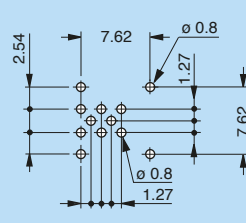

P11 - EPG-EXG (1B.308)
Screw mount

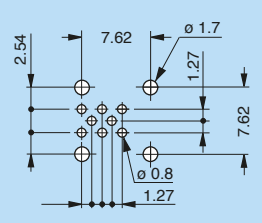

P11 - EPG-EXG (0B.309)
Solder mount

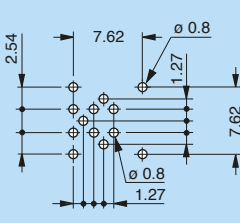

P11 - EPG-EXG (0B.309)
Screw mount

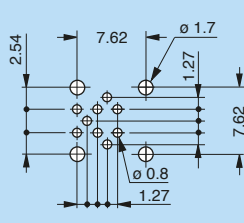

P11 - EPG-EXG (1B.310)
Solder mount

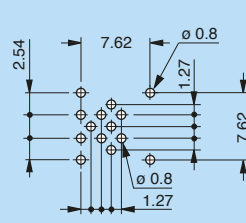

P11 - EPG-EXG (1B.310)
Screw mount

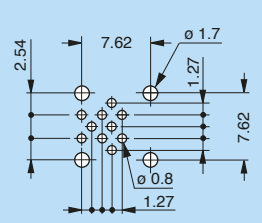

P12 - EPG.1B.314
Solder mount

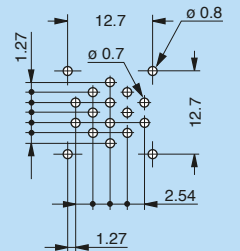

P12 - EPG.1B.314
Screw mount

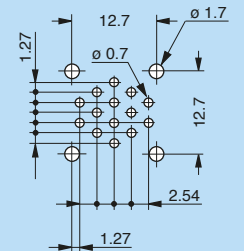

Cable assembly

Cable stripping lengths (B series)

M1 straight plugs and sockets with cable collet, clamping type D or M (solder or crimp contacts)

M3 elbow plugs (90°) with cable collet, clamping type D or M (solder or crimp contacts)

	Type	ø contact A (mm)	Cable stripping lengths (mm)											
			M1						M3					
			Solder			Crimp			Solder			Crimp		
			L	S	T	L	S	T	L	S	T	L	S	T
00	302/303/304	0.5	7.0	4	2.5	10.0	4	3.0	9.5	4	2.5	12.5	4	3.0
	305/306	0.35	7.0	4	2.5	–	–	–	9.5	4	2.5	–	–	–
0B¹⁾	302/303	0.9	14.5	7	3.5	17.0	7	4.0	19.5	7	3.5	22.0	7	4.0
	304/305	0.7	14.5	7	3.5	17.0	7	4.0	19.5	7	3.5	22.0	7	4.0
	306/307/309 ²⁾	0.5	14.0	7	2.5	18.0	7	3.0	19.0	7	2.5	23.0	7	3.0
	312	0.35	14.0	7	2.5	–	–	–	19.0	7	2.5	–	–	–
1B¹⁾	302/303	1.3	14.5	8	3.5	18.0	8	4.0	25.5	8	3.5	28.0	8	4.0
	304/305	0.9	14.5	8	3.0	18.0	8	4.0	25.5	8	3.0	28.0	8	4.0
	306/307/308	0.7	14.5	8	3.0	18.0	8	4.0	25.5	8	3.0	28.0	8	4.0
	310/314/316	0.5	16.5	8	2.5	–	–	–	27.5	8	2.5	–	–	–
XB	312	0.7	16.5	7.5	3.5	–	–	–	–	–	–	–	–	–
	322	0.5	17.5	8	4.0	–	–	–	–	–	–	–	–	–
2B	302	2.0	19.0	9	4.0	22.0	9	5.5	30.0	9	4.0	33.0	9	5.5
	303	1.6	19.0	9	3.5	22.0	9	5.5	30.0	9	3.5	33.0	9	5.5
	304/305/306/307	1.3	18.0	9	3.5	20.0	9	4.0	29.0	9	3.5	31.0	9	4.0
	308/310	0.9	17.0	9	3.0	20.0	9	4.0	28.0	9	3.0	31.0	9	4.0
	312/314/316/318/319	0.7	17.0	9	3.0	20.0	9	4.0	28.0	9	3.0	31.0	9	4.0
	326/332	0.5	17.0	9	2.5	–	–	–	28.0	9	2.5	–	–	–
3B	302	3.0	24.0	10	4.5	28.0	10	5.5	35.0	10	4.5	39.0	10	5.5
	303/304	2.0	23.0	10	4.0	27.0	10	5.5	34.0	10	4.0	38.0	10	5.5
	305/306/307	1.6	23.0	10	3.5	27.0	10	5.5	34.0	10	3.5	38.0	10	5.5
	308/310	1.3	22.0	10	3.5	25.0	10	4.0	33.0	10	3.5	36.0	10	4.0
	309	1.3 2.0	22.0	10	3.5 4.0	25.0	10	4.0 5.5	33.0	10	3.5 4.0	36.0	10	4.0 5.5
	312/314/316/318	0.9	21.0	10	3.0	25.0	10	4.0	32.0	10	3.0	36.0	10	4.0
	320/322/324/326/330/332	0.7	21.0	10	3.0	25.0	10	4.0	32.0	10	3.0	36.0	10	4.0

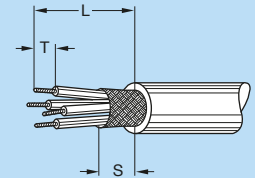

Note: ¹⁾ In 0B and 1B series, «L» and «S» dimensions shall be increased by 2 mm for the largest collet (D56 in 0B series; D76 in 1B series). The tolerances on these dimensions are: L: ± 0.5 mm; S: ± 0.5 mm; T: ± 0.2 mm.

Cable stripping lengths (B series)

M1 straight plugs and sockets with cable collet, clamping type D or M (solder or crimp contacts)

M3 elbow plugs (90°) with cable collet, clamping type D or M (solder or crimp contacts)

	Type	ø contact A (mm)	Cable stripping lengths (mm)											
			M1						M3					
			Solder			Crimp			Solder			Crimp		
			L	S	T	L	S	T	L	S	T	L	S	T
4B	304	3.0	33.0	12	4.5	36.0	12	5.5	41.0	12	4.5	45.0	12	5.5
	306/307	2.0	32.0	12	4.0	36.0	12	5.5	41.0	12	4.0	45.0	12	5.5
	310	1.6	32.0	12	3.5	36.0	12	5.5	39.0	12	3.5	43.0	12	5.5
	312	1.3	32.0	12	3.5	36.0	12	4.0	39.0	12	3.5	43.0	12	4.0
	316/320/324/330	0.9	32.0	12	3.0	34.0	12	4.0	39.0	12	3.0	43.0	12	4.0
	340/348	0.7	32.0	12	3.0	34.0	12	4.0	39.0	12	3.0	43.0	12	4.0
5B¹⁾	302	6.0	42.0	18	7.5	–	–	–	70.0	18	7.5	–	–	–
	304	4.0	47.0	18	5.5	50.0	18	7.0	75.0	18	5.5	78.0	18	7.0
	310	3.0	47.0	18	4.5	50.0	18	7.0	75.0	18	4.5	78.0	18	7.0
	314/316	2.0	46.0	18	4.0	49.0	18	5.5	74.0	18	4.0	77.0	18	5.5
	320	1.6	46.0	18	3.5	49.0	18	5.5	74.0	18	3.5	77.0	18	5.5
	330/340/348	1.3	45.0	18	3.5	48.0	18	4.0	74.0	18	3.5	77.0	18	4.0
	350/354/364	0.9	45.0	18	3.0	48.0	18	4.0	74.0	18	3.0	77.0	18	4.0

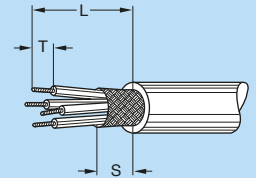

Note: ¹⁾ In 5B series, «L» and «S» dimensions shall be increased by 13 mm for the largest collet (D25).

M5 elbow plugs (90°) with cable collet, clamping type D or M (solder or crimp contacts) (FSG model)

	Type	ø contact A (mm)	Cable stripping lengths (mm)					
			M5					
			Solder			Crimp		
			L	S	T	L	S	T
00	302/303/304	0.5	12.0	4	2.5	15.0	5	3.0
	305/306	0.35	12.0	4	2.5	–	–	–
0B	302/303	0.9	21.5	7	3.5	24.0	7	4.0
	304/305	0.7	21.5	7	3.5	24.0	7	4.0
	306/307/309¹⁾	0.5	21.0	7	3.5	24.0	7	3.0
	312	0.35	21.0	7	3.5	–	–	–
1B	302/303	1.3	27.0	8	3.5	32.0	8	4.0
	304/305	0.9	27.0	8	3.5	32.0	8	4.0
	306/307²⁾/308	0.7	27.0	8	3.5	32.0	8	4.0
	310/314/316³⁾	0.5	29.0	8	3.5	–	–	–
2B	302	2.0	35.0	9	4.0	38.0	9	5.5
	303	1.6	35.0	9	4.0	38.0	9	5.5
	304/305/306/307	1.3	34.0	9	4.0	36.0	9	4.0
	308/310	0.9	33.0	9	4.0	36.0	9	4.0
	312/314/316/318/319	0.7	33.0	9	3.5	36.0	9	4.0
	326/332	0.5	33.0	9	3.5	–	–	–

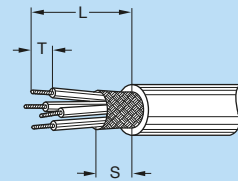

Note: ¹⁾ center wire L = 16.5. ²⁾ center wire L = 20.5. ³⁾ 5 center wires L = 20.5. The tolerances on these dimensions are: L: ± 0.5 mm; S: ± 0.5 mm; T: ± 0.2 mm.

Cable stripping lengths (B series)

M4 straight plug, short version, clamping type D or M (solder or crimp contacts)

	Type	ø contact A (mm)	Cable stripping lengths (mm)					
			M4					
			Solder			Crimp		
			L	S	T	L	S	T
0B	302/303	0.9	9.5	8	3.0	13.0	8	4.0
	304/305	0.7	9.5	8	3.0	13.0	8	4.0
	306/307/309 ²⁾	0.5	10.0	8	2.5	13.5	8	3.0

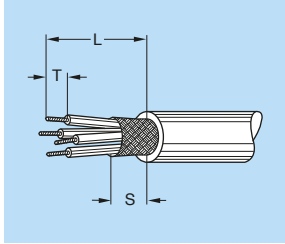

M2 straight plug, long version, clamping type D or M (solder or crimp contacts)

	Type	ø contact A (mm)	Cable stripping lengths (mm)					
			M2					
			Solder			Crimp		
			L	S	T	L	S	T
1B ¹⁾	302/303	1.3	39.5	8	3.5	43.0	8	4.0
	304/305	0.9	39.5	8	3.0	43.0	8	4.0
	306/307/308	0.7	39.5	8	3.0	43.0	8	4.0
	310/314/316	0.5	42.0	8	2.5	–	–	–
2B	302	2.0	49.0	9	4.0	53.0	9	5.5
	303	1.6	49.0	9	3.5	53.0	9	5.5
	304/305/306/307	1.3	48.0	9	3.5	50.0	9	4.0
	308/310	0.9	47.0	9	3.0	49.0	9	4.0
	312/314/316/318/319	0.7	47.0	9	3.0	49.0	9	4.0
	326/332	0.5	47.0	9	2.5	–	–	–

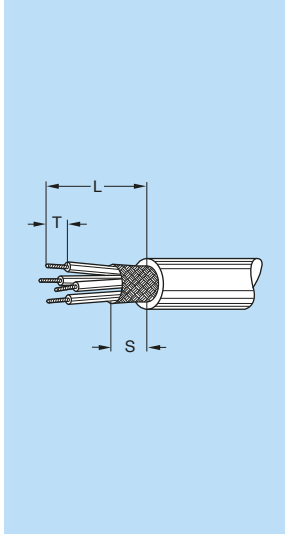

Note: 1) In 1B series, «L» and «S» dimensions shall be increased by 2 mm for the largest collet (D76 in 1B series).
 2) Crimp contacts are available only for connectors fitted with male contacts.
 The tolerances on these dimensions are: L: ± 0.5 mm; S: ± 0.5 mm; T: ± 0.2 mm.

Cable stripping lengths (K series)

M1 straight plugs and sockets with cable collet, clamping type C (solder or crimp contacts)

M3 elbow plug (90°) with cable collet, clamping type C (solder or crimp contacts)

	Type	ø contact A (mm)	Cable stripping lengths (mm)											
			M1						M3					
			Solder			Crimp			Solder			Crimp		
			L	S	T	L	S	T	L	S	T	L	S	T
0K	302/303	0.9	9.5	6	3.5	12.0	6	4.0	22.5	6	3.5	25.0	6	4.0
	304/305	0.7	9.5	6	3.5	12.0	6	4.0	22.5	6	3.5	25.0	6	4.0
	306/307/309 ¹⁾	0.5	9.0	6	2.5	13.0	6	4.0	22.0	6	2.5	26.0	6	4.0
	312	0.35	9.0	6	2.5	–	–	–	22.0	6	2.5	–	–	–
1K	302/303	1.3	11.0	7	3.5	14.5	7	4.0	27.5	7	3.5	31.0	7	4.0
	304/305	0.9	11.0	7	3.0	14.5	7	4.0	27.5	7	3.0	31.0	7	4.0
	306/307/308	0.7	11.0	7	3.0	14.5	7	4.0	27.5	7	3.0	31.0	7	4.0
	310/314/316	0.5	13.0	7	2.5	14.0	7	3.0	29.5	7	2.5	–	–	–
2K	302	2.0	16.5	8	4.0	19.5	8	5.5	36.0	8	4.0	39.0	8	5.5
	303	1.6	16.5	8	3.5	19.5	8	5.5	36.0	8	3.5	39.0	8	5.5
	304/305/306/307	1.3	15.5	8	3.5	17.5	8	4.0	35.0	8	3.5	37.0	8	4.0
	308/310	0.9	14.5	8	3.0	17.5	8	4.0	34.0	8	3.0	37.0	8	4.0
	312/314/316/318/319	0.7	14.5	8	3.0	17.5	8	4.0	34.0	8	3.0	37.0	8	4.0
	326/332	0.5	14.5	8	2.5	–	–	–	34.0	8	2.5	–	–	–
3K	302	3.0	19.0	10	4.5	23.0	10	5.5	48.0	10	4.5	53.0	10	5.5
	303/304	2.0	18.0	10	4.0	22.0	10	5.5	48.0	10	4.0	52.0	10	5.5
	305/306/307	1.6	18.0	10	3.5	22.0	10	5.5	48.0	10	3.5	52.0	10	5.5
	308/310	1.3	17.0	10	3.5	20.0	10	4.0	47.0	10	3.5	50.0	10	4.0
	309	1.3 2.0	17.0	10	3.5 4.0	20.0	10	4.0 5.5	47.0	10	3.5 4.0	50.0	10	4.0 5.5
	312/314/316/318	0.9	16.0	10	3.0	20.0	10	4.0	46.0	10	3.0	50.0	10	4.0
	320/322/324/326/330	0.7	16.0	10	3.0	20.0	10	4.0	46.0	10	3.0	50.0	10	4.0
4K	304	3.0	22.0	11	4.5	25.0	11	5.5	52.0	11	4.5	55.0	11	5.5
	306/307	2.0	21.0	11	4.0	25.0	11	5.5	51.0	11	4.0	55.0	11	5.5
	310	1.6	21.0	11	3.5	25.0	11	5.5	51.0	11	3.5	55.0	11	5.5
	312	1.3	21.0	11	3.5	25.0	11	4.0	51.0	11	3.5	55.0	11	4.0
	316/320/324/330	0.9	21.0	11	3.0	23.0	11	4.0	51.0	11	3.0	53.0	11	4.0
	340/348	0.7	21.0	11	3.0	23.0	11	4.0	51.0	11	3.0	53.0	11	4.0
5K	302	6.0	24.0	14	7.5	–	–	–	–	–	–	–	–	–
	304	4.0	29.0	14	5.5	32.0	14	7.0	–	–	–	–	–	–
	310	3.0	29.0	14	4.5	32.0	14	7.0	–	–	–	–	–	–
	314/316	2.0	28.0	14	4.0	31.0	14	5.5	–	–	–	–	–	–
	320	1.6	28.0	14	3.5	31.0	14	5.5	–	–	–	–	–	–
	330/340/348	1.3	27.0	14	3.5	30.0	14	4.0	–	–	–	–	–	–
	350/354/364	0.9	27.0	14	3.0	30.0	14	4.0	–	–	–	–	–	–

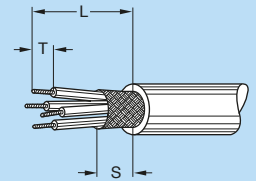

Note: ¹⁾ crimp contacts are available only for connectors fitted with male contacts.
The tolerances on these dim. are: L: ± 0.5 mm; S: ± 0.5 mm; T: ± 0.2 mm

Cable stripping lengths (K series)

M2 straight plug and socket with oversize cable collet, clamping type K (solder or crimp contacts)

	Type	ø contact A (mm)	Cable stripping lengths (mm)					
			M2					
			Solder			Crimp		
			L	S	T	L	S	T
1K	302/303	1.3	23.5	8	3.5	27.5	8	4.0
	304/305	0.9	23.5	8	3.0	27.5	8	4.0
	306/307/308	0.7	23.5	8	3.0	27.5	8	4.0
	310/314/316	0.5	24.5	8	2.5	–	–	–
2K	302	2.0	29.5	10	4.0	32.5	10	5.5
	303	1.6	29.5	10	3.5	32.5	10	5.5
	304/305/306/307	1.3	28.5	10	3.5	30.5	10	4.0
	308/310	0.9	27.5	10	3.0	30.5	10	4.0
	312/314/316/318/319	0.7	27.5	10	3.0	30.5	10	4.0
	326/332	0.5	27.5	10	2.5	–	–	–
3K	302	3.0	37.0	11	4.5	41.0	11	5.5
	303/304	2.0	36.0	11	4.0	40.0	11	5.5
	305/306/307	1.6	36.0	11	3.5	40.0	11	5.5
	308/310	1.3	35.0	11	3.5	38.0	11	4.0
	309	1.3 2.0	35.0	11	3.5 4.0	38.0	11	4.0 5.5
	312/314/316/318	0.9	34.0	11	3.0	38.0	11	4.0
	320/322/324/326/330	0.7	34.0	11	3.0	38.0	11	4.0
4K	304	3.0	45.0	14	4.5	48.0	14	5.5
	306/307	2.0	44.0	14	4.0	48.0	14	5.5
	310	1.6	44.0	14	3.5	48.0	14	5.5
	312	1.3	44.0	14	3.5	48.0	14	4.0
	316/320/324/330	0.9	44.0	14	3.0	46.0	14	4.0
	340/348	0.7	44.0	14	3.0	46.0	14	4.0

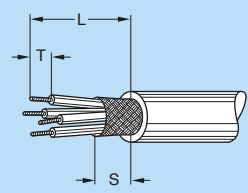

Note: the tolerances on these dim. are: L: ± 0.5 mm; S: ± 0.5 mm; T: ± 0.2 mm.

Cable stripping lengths (T series)

M1 straight plugs and sockets with cable collet, clamping type C (solder or crimp contacts)

M2 straight plugs and sockets with cable collet, clamping type K (solder or crimp contacts)

	Type	ø contact A (mm)	Cable stripping lengths (mm)											
			M1						M2					
			Solder			Crimp			Solder			Crimp		
			L	S	T	L	S	T	L	S	T	L	S	T
TT	302/303/304	0.5	10.0	4.5	2.5	13.5	4.5	3.0	–	–	–	–	–	–
	305	0.35	10.0	4.5	2.5	–	–	–	–	–	–	–	–	–
	306	0.35	11.0	4.5	2.5	–	–	–	–	–	–	–	–	–
OT	302/303	0.9	11.5	6.0	3.0	13.5	6.0	4.0	22.0	7.0	3.0	24.0	7.0	4.0
	304/305	0.7	11.5	6.0	3.0	13.5	6.0	4.0	22.0	7.0	3.0	24.0	7.0	4.0
	306/307/309 ¹⁾	0.5	10.5	6.0	2.5	14.0	6.0	3.0	21.0	7.0	2.5	24.5	7.0	3.0
	312	0.35	10.5	6.0	2.5	–	–	–	21.0	7.0	2.5	–	–	–
1T	302/303	1.3	12.0	8.0	3.5	14.0	8.0	4.0	26.0	8.5	3.5	28.0	8.5	4.0
	304/305	0.9	11.5	8.0	3.0	14.0	8.0	4.0	26.0	8.5	3.0	28.5	8.5	4.0
	306/307/308	0.7	11.5	8.0	3.0	14.0	8.0	4.0	26.0	8.5	3.0	28.5	8.5	4.0
	310/314/316	0.5	11.5	8.0	2.5	15.0	8.0	3.0	25.5	8.5	2.5	29.0	8.5	3.0
2T	302	2.0	16.0	9.5	4.0	19.0	9.5	5.5	30.0	9.0	4.0	33.0	9.0	5.5
	303	1.6	16.0	9.5	3.5	19.0	9.5	5.5	30.0	9.0	3.5	33.0	9.0	5.5
	304/305/306/307	1.3	16.0	9.5	3.5	19.0	9.5	4.0	30.0	9.0	3.5	33.0	9.0	4.0
	308/310	0.9	16.0	9.5	3.0	19.0	9.5	4.0	30.0	9.0	3.0	33.0	9.0	4.0
	312/314/316/318/319	0.7	16.0	9.5	3.0	19.0	9.5	4.0	30.0	9.0	3.0	33.0	9.0	4.0
	326/332	0.5	16.0	9.5	2.5	–	–	–	30.0	9.0	2.5	–	–	–
3T	302	3.0	20.5	11.0	4.5	23.5	11.0	7.0	40.5	13.0	4.5	43.5	13.0	7.0
	303/304	2.0	20.5	11.0	4.0	23.5	11.0	5.5	40.5	13.0	4.0	43.5	13.0	5.5
	305/306/307	1.6	20.5	11.0	3.5	23.5	11.0	5.5	40.5	13.0	3.5	43.5	13.0	5.5
	308/310	1.3	20.5	11.0	3.5	23.5	11.0	4.0	40.5	13.0	3.5	43.5	13.0	4.0
	309	1.3 2.0	20.5	11.0	3.5 4.0	23.5	11.0	4.0 5.5	40.5	13.0	3.5 4.0	43.5	13.0	4.0 5.5
	312/314/316/318	0.9	20.5	11.0	3.0	23.5	11.0	4.0	40.5	13.0	3.0	43.5	13.0	4.0
	320/322/324/326/330/332	0.7	20.5	11.0	3.0	23.5	11.0	4.0	40.5	13.0	3.0	43.5	13.0	4.0

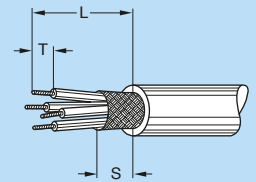

Note:

¹⁾ crimp contacts are available only for connectors fitted with male contacts. The tolerances on these dim. are: L: ± 0.5 mm; S: ± 0.5 mm; T: ± 0.2 mm.

Technical characteristics

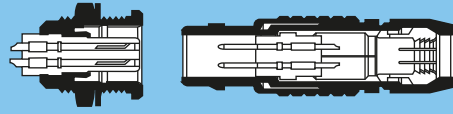

Outer shell

Brass

In most cases, LEMO connectors have a brass outer shell which is suitable for most general purpose applications, including civilian and military. The brass outer shells have a chrome nickel-plated surface which ensures very good protection against industrial atmosphere, salt air and most corrosive agents.

Alternative protective coatings are available to satisfy other specific environmental conditions:

- electrolytic nickel
- nickel-gold
- nickel-black chrome. After the black chrome treatment, the part is coated with non conductive protective organic film.

Stainless steel

For applications where there are severe environmental conditions that may rapidly damage the surface finish, we recommend using stainless steel. The AISI 303 stainless steel is a material for general use adapted to most applications requiring a product made entirely of stainless metal.

For the nuclear industry where elements are subject to radiation and to vaporous nitric acid, we offer AISI 304 stainless steel.

Grade AISI 316L is recommended for medical applications, highly demanding with regard to non-corrosiveness. This material is also used for connector shells soldered by electronic beam onto a device made of the same stainless steel. These parts have no surface treatment.

Aluminium alloy

The aluminium alloy outer shells find numerous applications where light weight is a predominant factor; such as in the aeronautics and space industries, and for portable and mobile equipment.

These materials have high mechanical strength and excellent resistance to corrosion. The shell surface is protected by anodizing which is available in six colours: blue, yellow, black, red, green, and natural.

Plastic materials

Some connector model shells can be made of plastic. This solution offers optimum electrical insulating properties particularly suitable for medical applications. Black Polyoxymethylene (POM) is particularly adapted to products of the 00 series.

Grey or white polysulfone (PSU) and beige PEEK offers excellent mechanical properties and is suitable for gas or vapour sterilization.

Some models of the 2B and 3B series are available with an outer shell of cream-coloured polyphenylsulfone (PPSU). We recommend this material particularly for applications where products are to withstand hundreds of vapour sterilization cycles.

Bridge plug or plugs with parallel sockets are made of polyamide (PA.6) available in 9 colours: blue, white, grey, yellow, brown, black, red, orange and green.

Some elbow socket shells for printed circuits are over-moulded in polyphenylene sulfide (PPS).

Other metallic components

In general, most metallic components are manufactured in brass. However, bronze or beryllium copper are used where good elasticity is required (for example: earthing crown). Depending on the application, these parts have electrolytic nickel or nickel-gold plating.

These parts can also be manufactured in stainless steel.

Sealing gasket

In general, sealing gaskets are made of silicone rubber MQ/MVQ. However, for vacuumtight sockets and couplers, gaskets are made of fluorocarbon elastomer (FPM/FKM).

Sealing resin

An epoxy resin is used to seal both watertight and vacuum-tight socket and coupler models.

Mechanical latching characteristics

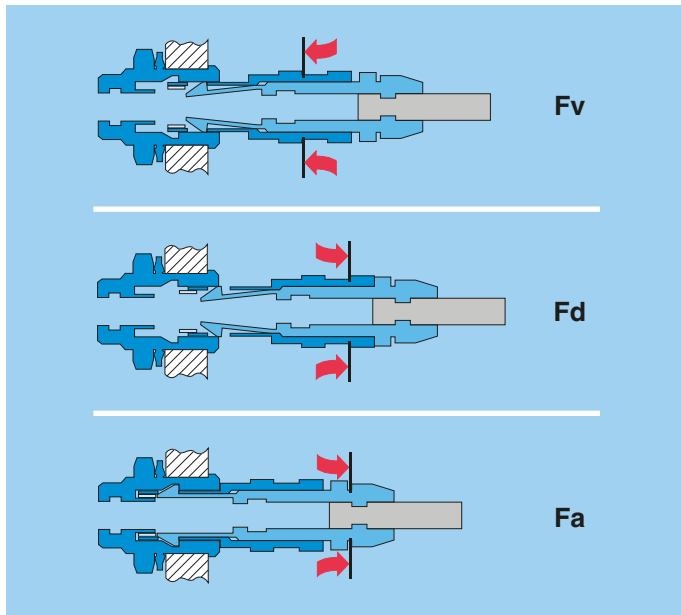

F_v: average latching force.

F_d: average unmating force with axial pull on the outer shell.

F_a: average pull force with axial pull on the collet nut

Keyed series

Force (N)	Series						
	00	0B	1B	2B	3B	4B	5B
F _v	9	10	14	15	17	39	48
F _d	7	8	11	12	14	38	38
F _a	100	180	300	300	400	600	800

Keyed watertight series

Force (N)	Series										
	TT	0K	0T	1K	1T	2K	2T	3K	3T	4K	5K
F _v	14	14	15	16	16	20	20	32	28	65	85
F _d	12	9	13	10	14	13	15	25	24	40	60
F _a	80	250	130	300	250	400	250	550	400	700	800

Notes: forces were measured on outer shells **not fitted with contacts**.
Mechanical endurance: 5000 cycles (3000 cycles for T series).
 The values were measured according to the standard IEC 60512-13-1 test 13a.

1N = 0.102 kg.

Electromagnetic compatibility (EMC) and shielding efficiency

The electromagnetic compatibility of a device can only be ensured by meeting a number of basic rules with the design of the device and by carefully selecting components, cables and connectors.

Electrical and electronic devices are to be designed to ensure the following:

- a) reduce the emission of generated electromagnetic disturbance to a level where radios and telecommunication and other devices can properly function;
- b) electromagnetic immunity against electromagnetic disturbance so that they can properly function.

When selecting a connector, screen or shielding efficiency and low resistance to electric continuity between the cable and the connector should be considered.

The design of LEMO connectors with metal shell and earthing crown guarantee optimum shielding efficiency in all applications where electromagnetic compatibility (EMC) is critical. The performance of a connector is measured through shielding efficiency, a value that represents the ratio between the electromagnetic field on the outside and the inside of the shell. Our measurements are carried out according to the IEC 60169-1-3 standard.

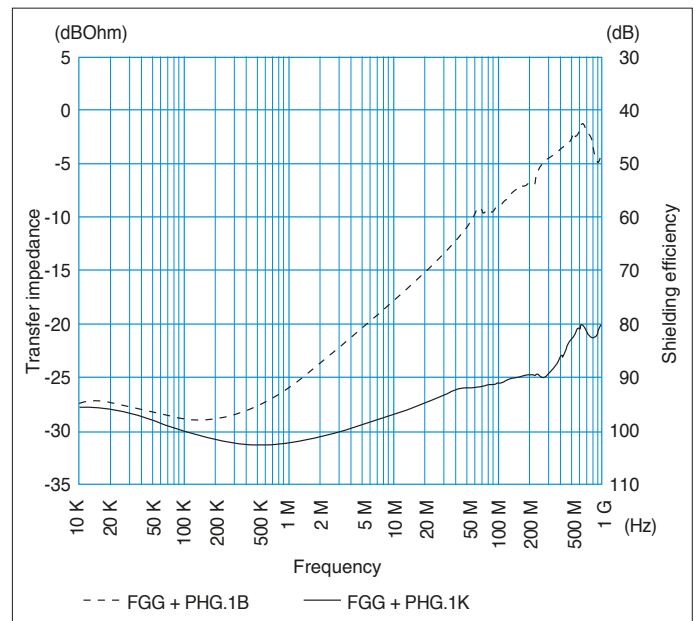

The performance of B series connectors is comparable to the results of measurements carried out on a pair of FGG + PHG.1B connectors.
 The performance of K series connectors is comparable to the results of measurements carried out on a pair of FGG + PHG.1K connectors.

Shell electrical continuity:
(measured according to IEC 60512-2-6 test 2f)

Test current: 1A
A = Ammeter
mV = Millivoltmeter
G = Generator

R_1 Values with earthing crown and latch sleeve or inner-sleeve nickel-plated.

R_2 Values with gold-plated earthing crown and nickel-plated latch sleeve or inner sleeve.

Keyed series

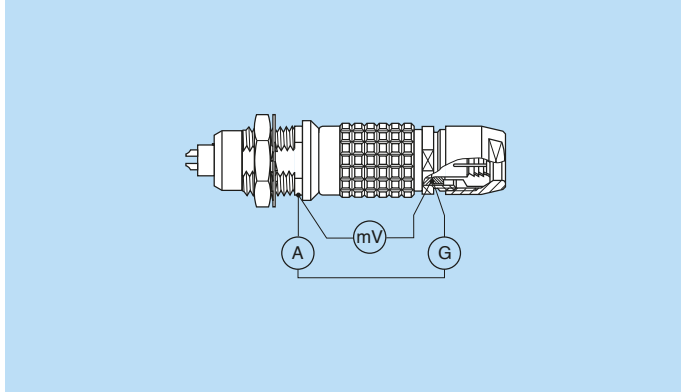

Series	R_1 (m Ω)	R_2 (m Ω)
00	3.5	2.8
0B	3.5	1.3
1B	2.5	1.1
XB	2.5	1.1
2B	2.2	0.9
3B	2.2	0.7
4B	1.5	0.5
5B	1.5	0.3

Series	R_1 (m Ω)
TT	3.5
0T	3.5
1T	2.5
2T	2.3
3T	2.2
4T	1.5
5T	1.5

Watertight series
Keyed watertight series

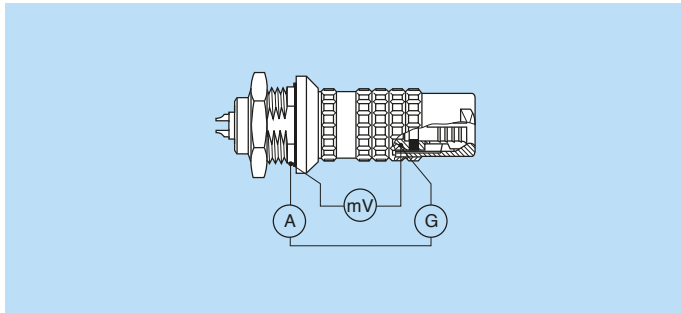

Series	R_1 (m Ω)	R_2 (m Ω)
0K	2.8	1.6
1K	2.2	1.5
2K	1.8	1.2
3K	1.6	1.2
4K	1.4	1.0
5K	1.4	1.0

Contact resistance with relation to the number of mating cycles

(measured according to IEC 60512-2-1 test 2a)

Average values measured after the mating cycles and the salt spray test according to IEC 60068-2-11 test Ka.

A ϕ (mm)	Contact resistance (m Ω)			A ϕ (mm)	Contact resistance (m Ω)		
	1000 cycles	3000 cycles	5000 cycles		1000 cycles	3000 cycles	5000 cycles
0.35	8.0	–	–	3.0	2.0	2.2	3.1
0.5	7.5	8.3	8.7	4.0	1.6	2.0	2.8
0.7	5.6	5.7	6.1	5.0	1.4	–	–
0.9	4.1	4.2	4.8	6.0	1.2	–	–
1.3	2.8	2.9	3.6	8.0	0.8	–	–
1.6	2.9	3.1	3.5	12.0	0.7	–	–
2.0	2.6	2.7	3.3				

Insulation resistance between the contacts and contact/shell

(measured according to IEC 60512-3-1 test 3a)

Insulating material	Multipole	Unipole
	PEEK	PTFE
new	> 10 ¹² Ω	> 10 ¹² Ω
after humidity test ¹⁾	> 10 ¹⁰ Ω	> 10 ¹⁰ Ω

Note: ¹⁾ 21 days at 95% RH according to IEC 60068-2-3.

Solder contacts

The conductor bucket of these contacts is machined at an angle to form a cup into which the solder can flow. See page 78 for the range of cable dimensions that can be soldered.

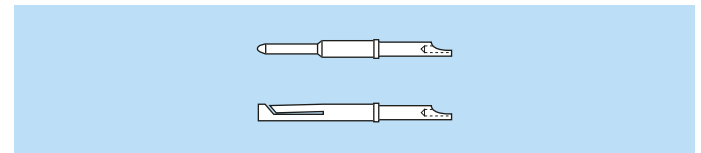

Crimp contacts

The square form crimp method is used (MIL-C-22520F, class I, type 2) photo 1 for unipole contacts.

For multipole contacts the standard four identer crimp method is used, MIL-C-22520F, class I, type 1), photo 2. The crimp method requires a controlled compression to obtain a symmetrical deformation of the conductor strand and of the contact material. The radial hole in the side of the contact makes it possible to check whether the conductor is correctly positioned within the contact. A good crimping is characterized by only slightly reduced conductor section and practically no gap.

For optimum crimping of bronze or brass contacts they are annealed to relieve internal stress and reduce material hardening during the crimping process.

Only the crimping zone is annealed with the help of an induction heating machine designed by the LEMO Research and Development Department (see photo 3).

Advantages of crimping

- practical, quick contact fixing outside the insulator
- possible use at high temperature
- no risk of heating the insulator during the conductor-contact fixing
- high tensile strength

Crimp contacts are available in standard version (form 1) for mounting maximum size conductors.

For some dimensions, these crimp contacts can be produced with reduced crimp barrels (form 2) for mounting reduced size conductors.

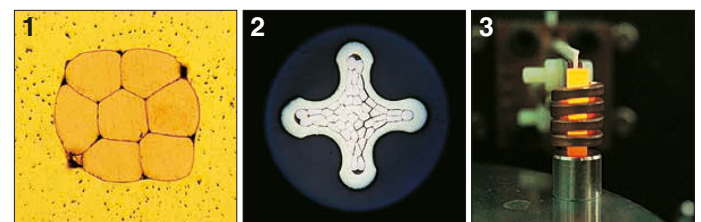

Crimp contacts

The crimp contacts can be with two forms: a standard crimp barrel for large conductors (see fig. 1) or with a reduced crimp barrel for smaller conductors (see fig. 2).

The range of cable dimensions that can be crimped into our contacts are indicated on the table on page 78.

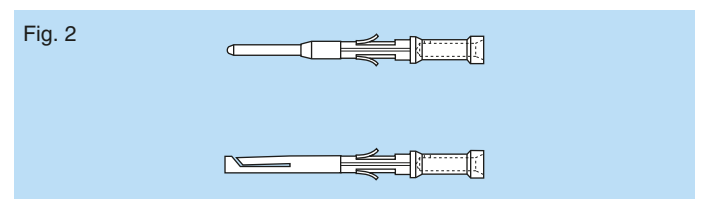
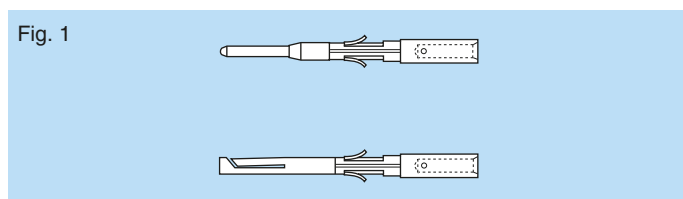

Print contacts

Print contacts are available in straight or elbow versions for certain connector types, mostly for straight and elbow socket models. Connection is made on flexible or rigid printed circuits by soldering.

Straight print contacts are gold-plated which guarantees optimum soldering, even after long-term storage. However

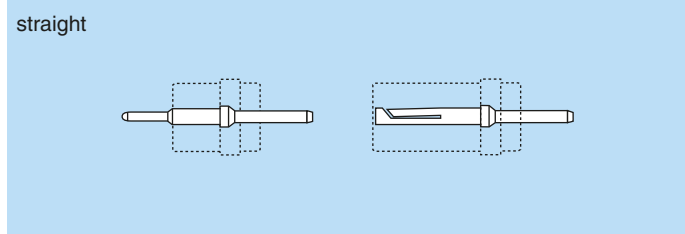

for wave soldering, we recommend removal the gold-plating from the contact end on the printed circuit side before soldering according to the assembly procedures.

Print elbow contacts include a tinned lead free brass wire crimped into a crimp contact.

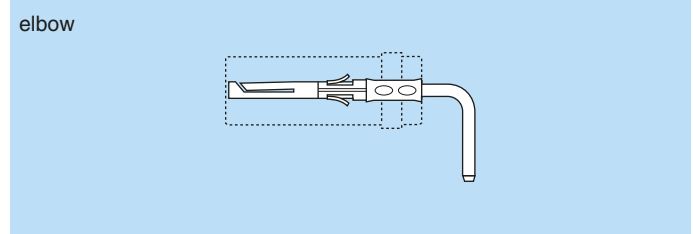

Test voltage

Test voltage (U_e) :
(measured according to the IEC 60512-4-1 test 4a standard)

It corresponds to 75% of the mean breakdown voltage.
Test voltage is applied at 500 V/s and the test duration is 1 minute.

This test has been carried out with a mated plug and socket, with power supply only on the plug end.

The operating voltage value definition is at the entire responsibility of the customer who defines this value according to the safety factors that they apply to their equipment and system.

Caution:
For a number of applications, safety requirements for electrical appliances are more severe with regard to operating voltage.
In such cases operating voltage is defined according to creepage distance and air clearance) between live parts.
Please consult us for the choice of a connector by indicating the safety standard to be met by the product.

Voltage values are given in the table on insulator types for each series.

They correspond with values measured at sea level. They are adapted to all applications up to an altitude of 2000 m.

In case a device is used at a higher altitude, air clearance between live parts has to be multiplied by the following coefficients.

It means also that test voltage has to be divided by this coefficient.

altitude (m)	coefficient
2000	1.00
3000	1.14
4000	1.29
5000	1.48

Rated current

(measured according to IEC 60512-5-1 test 5a)

The specified rated current can be applied simultaneously to all the contacts.

It corresponds with an average temperature rise of 40°C of the connector.

The current values are indicated in the table of insulator types in each series.

For use at higher temperatures acceptable rated current will be lower. It tends towards zero as the material is used at the maximum operating temperature accepted for the insulator.

In most case the current depend on the conductor dimension (see table on page 138) or on the printed circuit dimension.

Caution:
In general, connectors should not be unmated while live.

For connectors with PEEK insulator, maximum admissible current will follow the curve below depending on the operating temperature T.

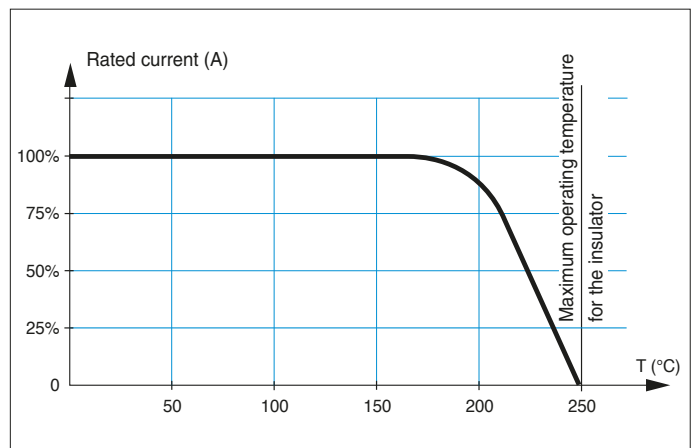

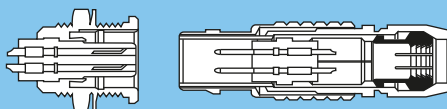

Cable clamping system

B series (D and M cable clamping)

See assembly instructions under www.lemo.com.

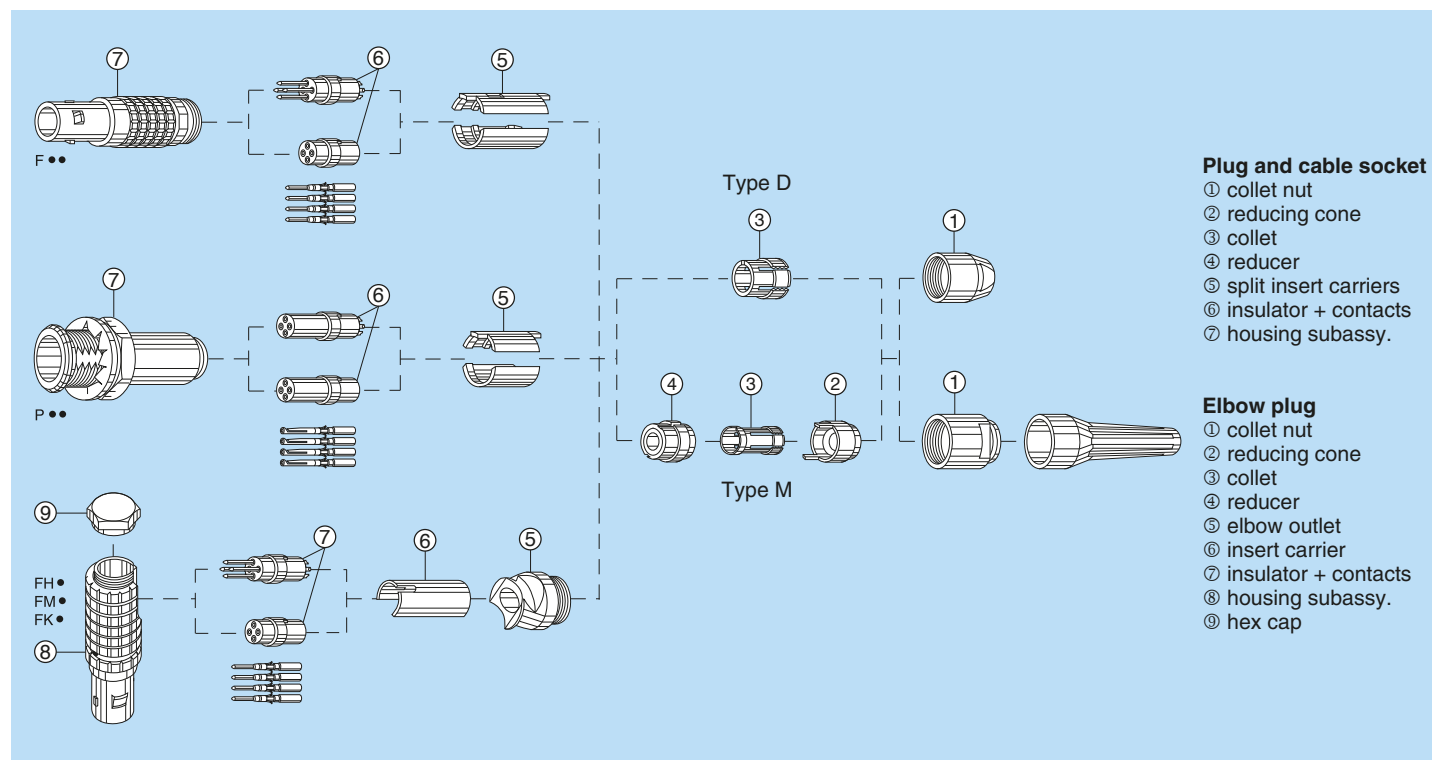

K series (C and K cable clamping)

See assembly instructions under www.lemo.com.

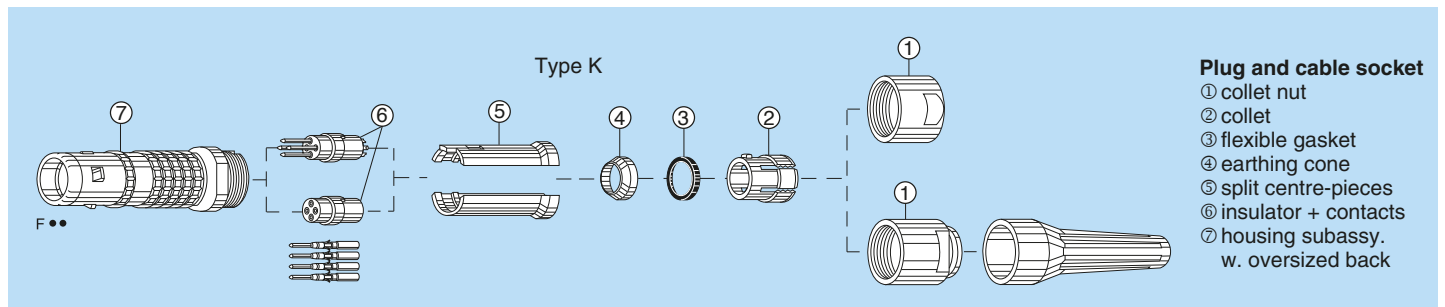
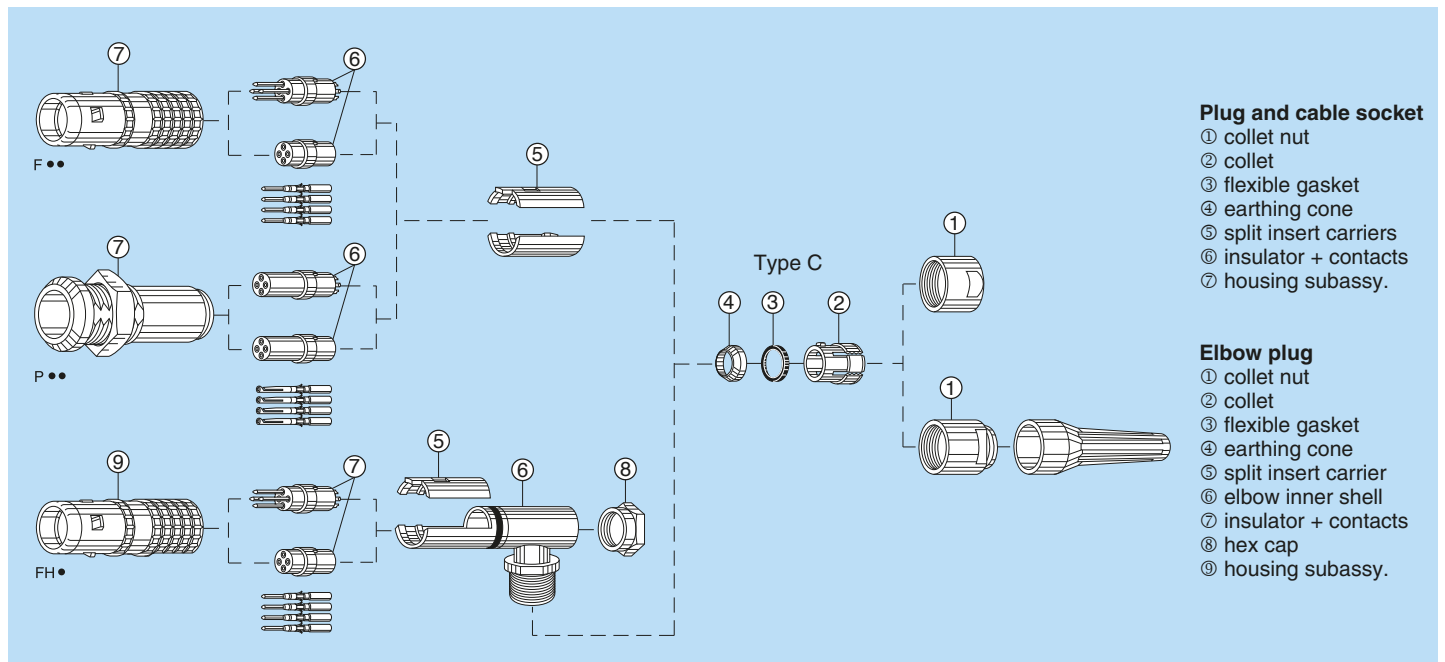

T series (C cable clamping)

See assembly instructions under www.lemo.com.

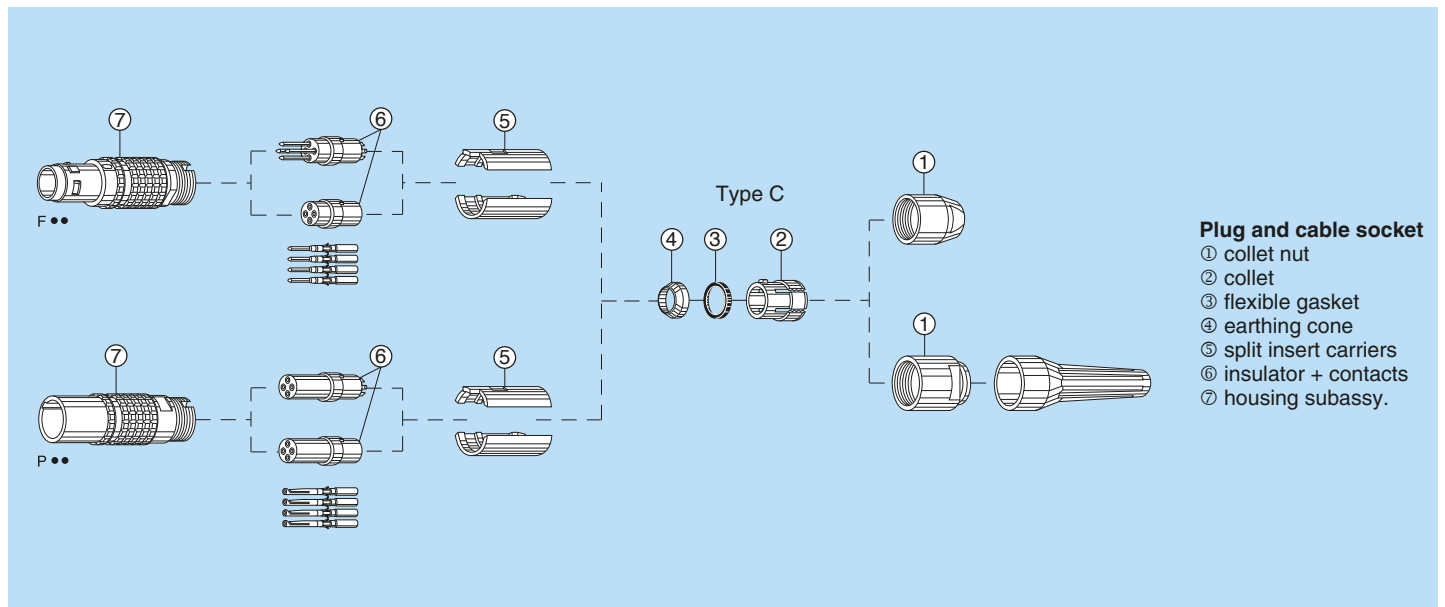

Maximum metal collet nut tightening torque

Keyed series

	Series							
	00	0B	1B	XB	2B	3B	4B	5B
Torque (Nm)	0.25	0.5	1.5	2.0	2.5	4	7	10

Watertight keyed series

	Series										
	TT	0K	0T	1K	1T	2K	2T	3K	3T	4K	5K
Torque (Nm)	0.25	0.7	0.7	0.8	0.8	2	2	3	3	5	8

Maximum elbow plug hex cap tightening torque

Keyed series

	Series						
	00	0B	1B	2B	3B	4B	5B
Torque (Nm)	0.2	0.25	0.5	0.5	1.5	3	5

Watertight keyed series

	Series					
	0K	1K	2K	3K	4K	5K
Torque (Nm)	0.8	1	1.2	1.5	3	5

1N = 0.102 kg

Maximum plastic collet nut tightening torque ¹⁾

	Series			
	1B	2B	3B	4B
Torque (Nm)	0.50	0.50	1.00	1.50

Note: ¹⁾ For applications subject to strong vibration, we recommend fixing the collet nut with epoxy resin. We recommend to tight to the maximum value. Optimal torque may depend on cable jacket design.

Technical tables

Table of American Wire Gauge

AWG	Construction		ø wire max		Wire section	
	Strand nb	AWG/strand	(mm)	(in)	(mm ²)	(sq in)
0	259	24	11.277	0.444	52.90	0.0820
1	817	30	9.702	0.382	41.40	0.0641
2	259	26	8.89	0.35	33.20	0.0514
4	133	25	6.9596	0.274	21.5925	0.0335
6	133	27	5.5118	0.217	13.5885	0.0211
8	168	30	4.4450	0.175	8.5127	0.0132
8	133	29	4.3942	0.173	8.6053	0.0133
10	105	30	3.3020	0.13	5.3204	0.0082
10	37	26	2.9210	0.115	4.7397	0.0073
10	1	10	2.6162	0.103	5.2614	0.0082
12	37	28	2.3114	0.091	2.9765	0.0046
12	19	25	2.3622	0.093	3.0847	0.0048
12 ¹⁾	7	20	2.5400	0.10	3.6321	0.0056
12	1	12	2.0828	0.082	3.3081	0.0051
14	41	30	2.0574	0.081	2.0775	0.0032
14	19	27	1.8542	0.073	1.9413	0.0030
14 ¹⁾	7	22	2.0828	0.082	2.2704	0.0035
14	1	14	1.6510	0.065	2.0820	0.0032
16 ¹⁾	65	34	1.5748	0.062	1.3072	0.0020
16	26	30	1.5748	0.062	1.3174	0.0020
16	19	29	1.4986	0.059	1.2293	0.0019
16 ¹⁾	7	24	1.5494	0.061	1.4330	0.0022
16	1	16	1.3208	0.052	1.3076	0.0020
18 ¹⁾	65	36	1.2700	0.05	0.8234	0.0013
18 ¹⁾	42	34	1.2700	0.05	0.8447	0.0013
18	19	30	1.3208	0.052	0.9627	0.0015
18	16	30	1.2954	0.051	0.8107	0.0013
18	7	26	1.2700	0.05	0.8967	0.0014
18	1	18	1.0414	0.041	0.8229	0.0013

AWG	Construction		ø wire max		Wire section	
	Strand nb	AWG/strand	(mm)	(in)	(mm ²)	(sq in)
20 ¹⁾	42	36	1.0160	0.04	0.5320	8.2x10 ⁻⁴
20	19	32	1.0414	0.041	0.6162	0.0010
20	10	30	1.0160	0.04	0.5067	7.9x10 ⁻⁴
20	7	28	0.9906	0.039	0.5631	8.7x10 ⁻⁴
20	1	20	0.8382	0.033	0.5189	8.0x10 ⁻⁴
22	19	34	0.8382	0.033	0.3821	5.9x10 ⁻⁴
22	7	30	0.7874	0.031	0.3547	5.5x10 ⁻⁴
22	1	22	0.6604	0.026	0.3243	5.0x10 ⁻⁴
24 ¹⁾	42	40	0.6604	0.026	0.2045	3.2x10 ⁻⁴
24	19	36	0.6858	0.027	0.2407	3.7x10 ⁻⁴
24	7	32	0.6350	0.025	0.2270	3.5x10 ⁻⁴
24	1	24	0.5588	0.022	0.2047	3.2x10 ⁻⁴
26	19	38	0.5588	0.022	0.1540	2.4x10 ⁻⁴
26	7	34	0.5080	0.02	0.1408	2.2x10 ⁻⁴
26	1	26	0.4318	0.017	0.1281	2.0x10 ⁻⁴
28 ¹⁾	19	40	0.4318	0.017	0.0925	1.4x10 ⁻⁴
28	7	36	0.4064	0.016	0.0887	1.4x10 ⁻⁴
28	1	28	0.3302	0.013	0.0804	1.2x10 ⁻⁴
30	7	38	0.3302	0.013	0.0568	8.8x10 ⁻⁵
30	1	30	0.2794	0.011	0.0507	7.9x10 ⁻⁵
32	7	40	0.2794	0.011	0.0341	5.3x10 ⁻⁵
32	1	32	0.2286	0.009	0.0324	5.0x10 ⁻⁵
34	1	34	0.1693	0.007	0.0201	3.1x10 ⁻⁵
36	1	36	0.127	0.005	0.0127	2.0x10 ⁻⁵
38	1	38	0.1016	0.004	0.0081	1.3x10 ⁻⁵
40	1	40	0.078	0.003	0.0049	7.5x10 ⁻⁶

Note: ¹⁾ not included in the standard

Table of wire gauges according to IEC-60228 standard

Conductor no x Ø (mm)	Max Ø (mm)	Max Ø (in)	Section (mm ²)	Section (sq in)
196x0.40	7.50	0.295	25.00	0.0387
7x2.14	6.10	0.240	25.00	0.0387
125x0.40	6.00	0.236	16.00	0.0248
7x1.72	4.90	0.192	16.00	0.0248
1x4.50	4.50	0.177	16.00	0.0248
80x0.40	4.70	0.155	10.00	0.0155
7x1.38	3.95	0.155	10.00	0.0155
1x3.60	3.60	0.141	10.00	0.0155
84x0.30	3.70	0.145	6.00	0.0093
7x1.50	3.15	0.124	6.00	0.0093
1x2.76	2.76	0.108	6.00	0.0093
56x0.30	2.80	0.110	4.00	0.0062
7x0.86	2.58	0.098	4.00	0.0062
1x2.25	2.25	0.082	4.00	0.0062
50x0.25	2.15	0.084	2.50	0.0038
7x0.68	2.04	0.080	2.50	0.0038
1x1.78	1.78	0.070	2.50	0.0038
30x0.25	1.60	0.062	1.50	0.0023
7x0.52	1.56	0.061	1.50	0.0023

Conductor no x Ø (mm)	Max Ø (mm)	Max Ø (in)	Section (mm ²)	Section (sq in)
1x1.40	1.40	0.055	1.50	0.0023
32x0.20	1.35	0.053	1.00	0.0015
7x0.43	1.29	0.050	1.00	0.0015
1x1.15	1.15	0.045	1.00	0.0015
42x0.15	1.20	0.047	0.75	0.0011
28x0.20	1.15	0.045	0.75	0.0011
1x1.00	1.00	0.039	0.75	0.0011
28x0.15	0.95	0.037	0.50	7.7x10 ⁻⁴
16x0.20	0.90	0.035	0.50	7.7x10 ⁻⁴
1x0.80	0.80	0.031	0.50	7.7x10 ⁻⁴
7x0.25	0.75	0.029	0.34	5.2x10 ⁻⁴
1x0.60	0.60	0.023	0.28	4.3x10 ⁻⁴
14x0.15	0.75	0.029	0.25	3.8x10 ⁻⁴
7x0.20	0.65	0.023	0.22	3.4x10 ⁻⁴
18x0.10	0.50	0.019	0.14	2.1x10 ⁻⁴
14x0.10	0.40	0.015	0.11	1.7x10 ⁻⁴
21x0.07	0.40	0.015	0.09	1.3x10 ⁻⁴
14x0.10	0.40	0.015	0.09	1.3x10 ⁻⁴

Maximum current rating for conductor

Maximum current on insulated conductors up to an ambient temperature of 30° C (from VDE 0100, parts 430 and 532 as well as other VDE regulations).

Nominal section mm ²	Group 2 Intens. max. A	Group 3 Intens. max. A
0.08	1.0	1.5
0.14	2.0	3.0
0.25	4.0	5.0
0.34	6.0	8.0
0.50	9.0	12.0
0.75	12.0	15.0
1.00	15.0	19.0
1.50	18.0	24.0
2.50	26.0	32.0

Group 2 Multi-conductor, e. g. solid cable under sheath, shielded cable, lead-sheath cables, ...
 Group 3 Single conductor and single conductor cable laid on open air in a way to leave at least a space between them equal to their diameter

Product safety notice & Disclaimers

**PLEASE READ AND FOLLOW ALL INSTRUCTIONS CAREFULLY AND CONSULT ALL RELEVANT NATIONAL AND INTERNATIONAL SAFETY REGULATIONS FOR YOUR APPLICATION.
IMPROPER HANDLING, CABLE ASSEMBLY, OR WRONG USE OF CONNECTORS CAN RESULT IN HAZARDOUS SITUATIONS.**

1. SHOCK AND FIRE HAZARD

Incorrect wiring, the use of damaged components, presence of foreign objects (such as metal debris), and / or residue (such as cleaning fluids), can result in short circuits, overheating, and / or risk of electric shock.

Mated components should never be disconnected while live as this may result in an exposed electric arc and local overheating, resulting in possible damage to components.

2. HANDLING

Connectors and their components should be visually inspected for damage prior to installation and assembly. Suspect components should be rejected or returned to the factory for verification.

Connector assembly and installation should only be carried out by properly trained personnel. Proper tools must be used during installation and / or assembly in order to obtain safe and reliable performance.

3. USE



Connectors with exposed contacts should never be live (or on the current supply side of a circuit). Under general conditions voltages above 30 VAC and 42 VDC are considered hazardous and proper measures should be taken to eliminate all risk of transmission of such voltages to any exposed metal part of the connector.

4. TEST AND OPERATING VOLTAGES

The maximum admissible operating voltage depends upon the national or international standards in force for the application in question. Air and creepage distances impact the operating voltage; reference values are indicated in the catalogue however these may be influenced by PC board design and / or wiring harnesses.

The test voltage indicated in the catalogue is 75% of the mean breakdown voltage; the test is applied at 500 V/s and the test duration is 1 minute.

5. CE MARKING

CE marking  means that the appliance or equipment bearing it complies with the protection requirements of one or several European safety directives. CE marking  applies to complete products or equipment, **but not to electromechanical components, such as connectors.**

6. PRODUCT IMPROVEMENTS

The LEMO Group reserves the right to modify and improve to our products or specifications without providing prior notification.

7. WARNING (Prop 65 State of California)

Proposition 65 requires businesses to provide warnings to Californians about significant exposures to chemicals that cause cancer, birth defects or other reproductive harm. LEMO products are exempt from proposition 65 warnings because they are manufactured, marketed, and sold solely for commercial and industrial use.

For further information, please visit: <https://web.lemo.com/img/resources/quality/LEMO-Prop-65-compliance-declaration.pdf>

8. UL RECOGNITION

LEMO connectors are components recognized by the Underwriters Laboratories (UL), facilitating the UL approval of the complete system (including LEMO connector, cable and your equipment).

9. REACH AND ROHS

LEMO connector specifications comply with the requirements of the RoHS directive (2011/65/EU) and REACH regulation (1907/2006/EU) of the European Parliament and latest amendments. These REACH and ROHS regulations specify the restrictions of the use of hazardous substances in LEMO products marketed in Europe.

DISCLAIMERS

LEMO works constantly to improve the quality of its products; the information and illustrations figuring in this document may therefore vary and are not binding. In any case, LEMO makes no specific warranty of merchantability, fitness for a particular purpose, third party components as such or included in assembly, non-infringement, title, accuracy, completeness, or security. The user is fully responsible for his products and applications using LEMO component.

In no event shall LEMO, its affiliates, officers, agents or employees be liable for any incidental, indirect, special or consequential damages in connection with the products or services provided by LEMO, including (without limitation) loss of profits or revenues, interruption of business, loss of use of the products or any associated equipment, materials, components or products, damages to associated equipment or in combination with other components, materials.

Reproduction of significant portions of LEMO information in LEMO data books or data sheets is permissible only if reproduction is without alteration and is accompanied by all associated warranties, conditions, limitations, and notices. LEMO is not responsible or liable for such altered documentation. Information of third parties may be subject to additional restrictions.



HEADQUARTERS
Switzerland

LEMO SA
Tel: +41 21 695 16 00
info@lemo.com

Subsidiaries & distributors



Online catalogue



lemo.com

