



Ag9900

Ultra-Miniature PoE Module



Features

- IEEE802.3af compliant
- 1500V isolated DC/DC Converter
- Tiny SMT (14x21x13mm) or Low profile SMT and DIL (14x21x8mm) packages
- Low cost
- Input voltage range 36V to 57V
- Minimal external components required
- Short-circuit protection
- Industrial temperature range option
- Over temperature protection (Industrial Temperature versions only)
- Adjustable Output
- Silvertel “design-in” assistance
- Designed and manufactured in the UK

Description

The Ag9900 Power-over-Ethernet (PoE) modules are the smallest POE solution in the world and designed to extract power from a conventional twisted pair Category 5 Ethernet cable, conforming to the IEEE 802.3af PoE standard.

The Ag9900 signature and control circuit provides the PoE compatibility signature required by the Power Sourcing Equipment (PSE) before applying up to 15W power to the port. The Ag9900 provides a Class 0 signature.

The DC/DC converter operates over a wide input voltage range and provides a regulated output. The DC/DC converter also has built-in short-circuit output protection.

Table of Contents

1	Product Overview	3
1.1	Ag9900 Product Selector	3
1.2	Package Format and Pin Description	4
2	Functional Description	6
2.1	Typical Connections	6
2.2	Input.....	7
2.2.1	PD Signature.....	7
2.2.2	Power Classification.....	7
2.2.3	Start-up Power	7
2.3	Output.....	8
2.3.1	Output Adjustment	8
2.3.2	Additional Output Filtering.....	9
2.3.3	Minimum Load.....	9
3	Operating Temperature Range	10
3.1	Thermal Considerations	11
4	Protection	13
4.1	Input Protection	13
4.2	Thermal Protection	13
5	Typical Application	14
6	Isolation	15
7	EMC	15
8	Solderability	16
8.1	Solder Profile	16
9	Electrical Characteristics	17
9.1	Absolute Maximum Ratings ¹	17
9.2	Recommended Operating Conditions	17
9.3	DC Electrical Characteristics.....	18
10	Package Dimensions	20
11	Land Patterns	22
12	Ordering Code	24
13	Packaging	24

Table of Figures

Figure 1:	Block Diagram	4
Figure 2:	Ag9900-MTB and Ag9900-LPB Package Format	4
Figure 3:	Gull Wing SMT Package Format.....	5
Figure 4:	Low Profile DIL Package Format.....	5
Figure 5:	Typical Connection Diagram	6
Figure 6:	Typical System Diagram	7
Figure 7:	Output Adjustment.....	8
Figure 8:	Output Filtering	9
Figure 9:	Ag9900-MT(B) Operating Profile	10
Figure 10:	Ag9900-LP(B) Operating Profile.....	10
Figure 11:	Ag9900-M Operating Profile	11
Figure 12:	Ag9900 Thermal Relief.....	12
Figure 13:	Thermal Paste Region.....	12
Figure 14:	Ag9900 Input Protection	13
Figure 15:	Typical Application	14
Figure 16:	EMC Filtering	15
Figure 17:	Ag9900-MTB Package Dimensions	20
Figure 18:	Ag9900-LPB Package Dimensions	20
Figure 19:	Ag9900-M(T) Package Dimensions	21
Figure 20:	Ag9900-LP Package Dimensions.....	21
Figure 21:	Ag9900-MTB and Ag9900-LPB Variant Reflow Land Pattern	22
Figure 22:	Ag9900-MTB and Ag9900-LPB Variant Hand Soldering Land Pattern.....	22
Figure 23:	Gull Wing SMT Variant Land Pattern	23
Figure 24:	Low Profile DIL Variant Land Pattern	23
Figure 25:	Tape Dimensions	24
Figure 26:	Reel Dimensions	25

1 Product Overview

1.1 Ag9900 Product Selector

Part Number ¹	Package format	Marking ²	Temperature Range	Nominal Output Voltage	Output Power		Status
					70°C	85°C	
Ag9903-MTB	SMT	ab03	Industrial	3.3V	6W	4.5W	Preferred
Ag9905-MTB	SMT	ab05	Industrial	5.0V	9W	6W	Preferred
Ag9912-MTB	SMT	ab12	Industrial	12.0V	12W	9W	Preferred
Ag9924-MTB	SMT	ab24	Industrial	24.0V	12W	12W	Preferred
Ag9903-LPB	Low Profile SMT	ab03	Industrial	3.3V	4.9W	3.6W	Preferred
Ag9905-LPB	Low Profile SMT	ab05	Industrial	5.0V	7W	4.5W	Preferred
Ag9912-LPB	Low Profile SMT	ab12	Industrial	12.0V	10W	6W	Preferred
Ag9903-M	Gull Wing SMT	WWYY, 3	Standard	3.3V	6W	-	
Ag9903-MT	Gull Wing SMT	WWYY, 3T	Industrial	3.3V	6W	4.5W	
Ag9905-M	Gull Wing SMT	WWYY, 5	Standard	5.0V	9W	-	
Ag9905-MT	Gull Wing SMT	WWYY, 5T	Industrial	5.0V	9W	6W	
Ag9912-M	Gull Wing SMT	WWYY, 12	Standard	12.0V	12W	-	
Ag9912-MT	Gull Wing SMT	WWYY,	Industrial	12.0V	12W	9W	
Ag9924-M	Gull Wing SMT	WWYY, 24	Standard	24.0V	12W	-	
Ag9924-MT	Gull Wing SMT	WWYY,	Industrial	24.0V	12W	12W	
Ag9903-LP	Low Profile DIL	WW, YY, 3	Industrial	3.3V	4.9W	3.6W	
Ag9905-LP	Low Profile DIL	WW, YY, 5	Industrial	5.0V	7W	4.5W	
Ag9912-LP	Low Profile DIL	WW, YY,	Industrial	12.0V	10W	6W	

Note 1: The Ag9900 complies with the European Directive 2011/65/EU for the Restriction of use of certain Hazardous Substances (RoHS) including Directive 2015/863 published in 2015, amending Annex II of Directive 2011/65/EU. Moisture Sensitive Level 1 and HBM 1.

Note 2: Voltage and Date code marking depending on variant:

For all Ag9900-MTB and Ag9900-LPB Variants:

Located on the topside of the PCB above pin 5 for LPB Variants and on the transformer for MTB variants.

The first letter, a, indicates the week as A-Z with uppercase being weeks 1-26, lower case weeks 27-52.

The second letter, b, indicates the year in uppercase A-Z starting from 2020.

The two digits are the nominal output voltage,

For Gull Wing SMT Variants:

Located on the transformer.

Date code format: "WW" = Week Number, "YY" = Year.

For Low Profile DIL Variants:

Located on the PCB on the underside of the module in three sections.

Date code format: "WW" = Week Number, "YY" = Year.

Table 1: Ordering Information

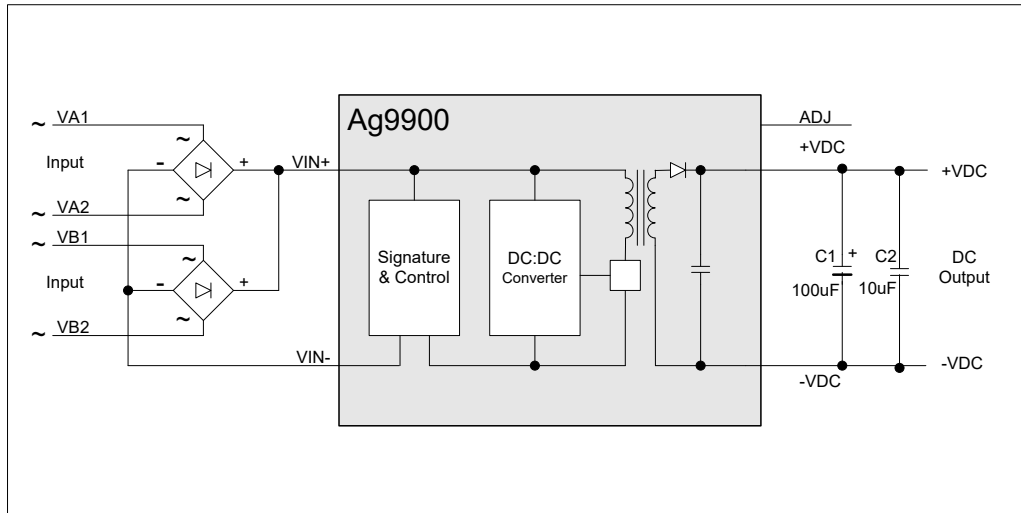

Figure 1: Block Diagram

1.2 Package Format and Pin Description

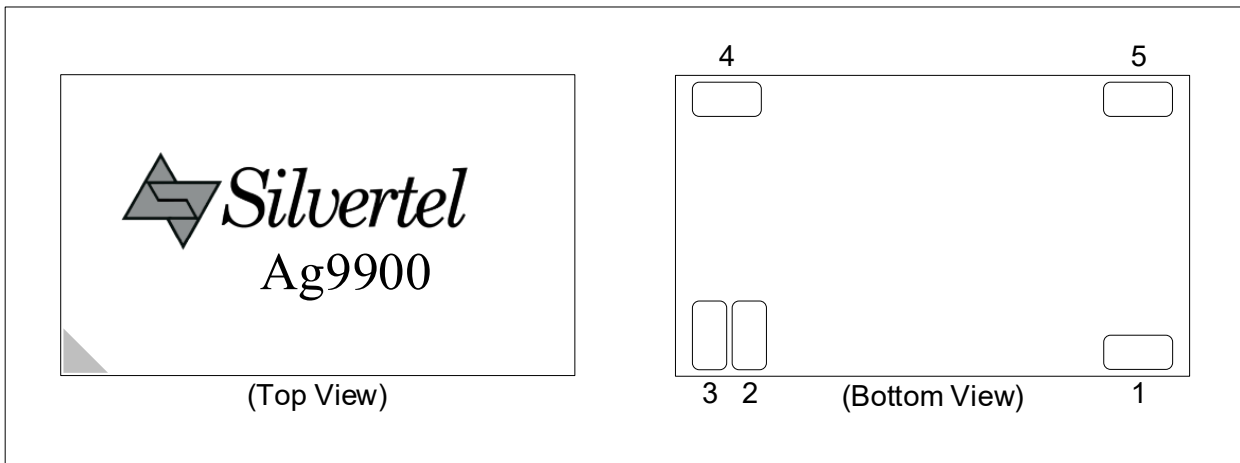

Figure 2: Ag9900-MTB and Ag9900-LPB Package Format

Pin #	Name	Description
1	+VDC	DC Output This pin provides the regulated output from the DC/DC converter.
2	-VDC	DC Return This pin is the return path for the +VDC output.
3	ADJ	Output Adjust The output voltage can be adjusted from its nominal value, by connecting an external resistor from this pin to either the +VDC pin or the -VDC pin.
4	VIN+	Direct Input + This pin connects to the positive (+) output of the input bridge rectifiers.
5	VIN-	Direct Input - This pin connects to the negative (-) output of the input bridge rectifiers.

Table 2: Ag9900-MTB and Ag9900-LPB Pin Description

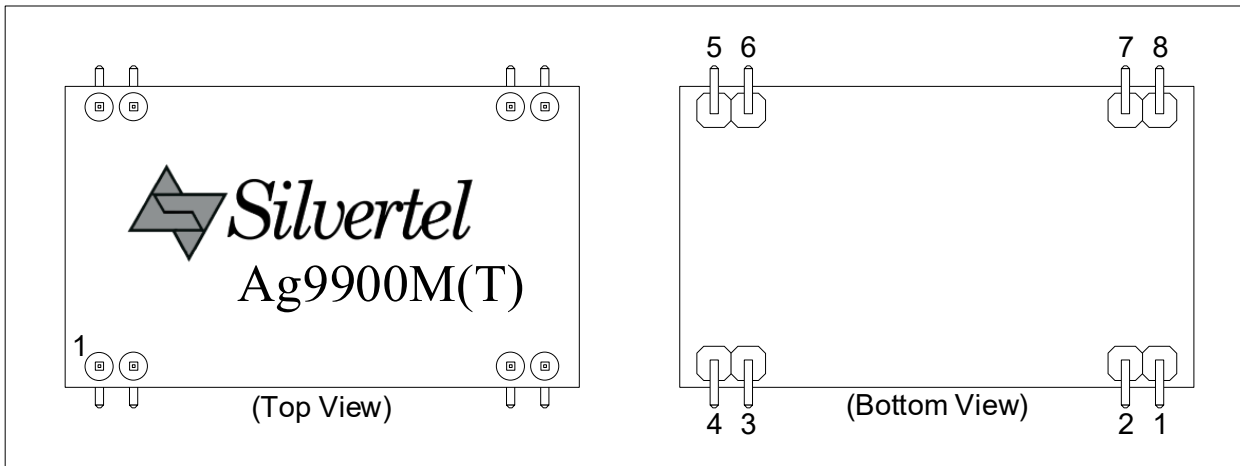

Figure 3: Gull Wing SMT Package Format

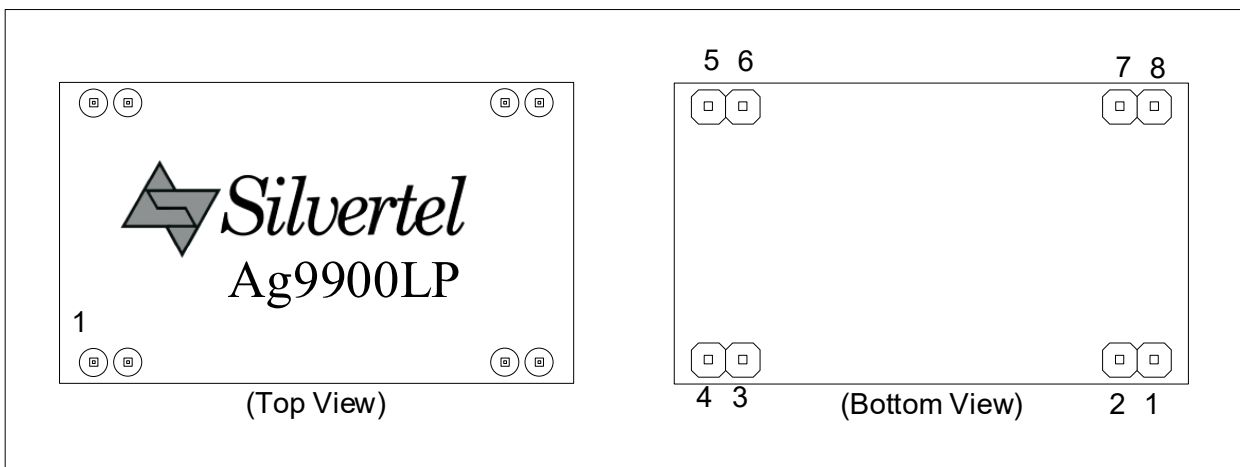

Figure 4: Low Profile DIL Package Format

Pin #	Name	Description
1	+VDC	DC Output This pin provides the regulated output from the DC/DC converter.
2		
3	-VDC	DC Return This pin is the return path for the +VDC output.
4	ADJ	Output Adjust The output voltage can be adjusted from its nominal value, by connecting an external resistor from this pin to either the +VDC pin or the -VDC pin.
5	VIN+	Direct Input + This pin connects to the positive (+) output of the input bridge rectifiers.
6		
7	VIN-	Direct Input - This pin connects to the negative (-) output of the input bridge rectifiers.
8		

Table 3: Gull Wing SMT and Low Profile DIL Pin Description

2 Functional Description

2.1 Typical Connections

The Ag9900 requires minimal external components as shown in Figure 5.

C1 must be fitted for output stability and should be a minimum of 100 μ F. This capacitor should be positioned as close to the output pins as possible. C1 is also required to handle load step change and reduce the output ripple. For applications where the output needs to cope with high load step changes, or to reduce the output ripple we recommend using a low ESR electrolytic. When intended for used in ambient temperatures below 0°C it is recommended that an output capacitor that will retain the minimum output capacitance and ESR ratings for the Ag9900 at the lowest temperature in the intended operating range is used.

BR1 and BR2 can be inexpensive bridge rectifiers, for example MB4S or MB6S.

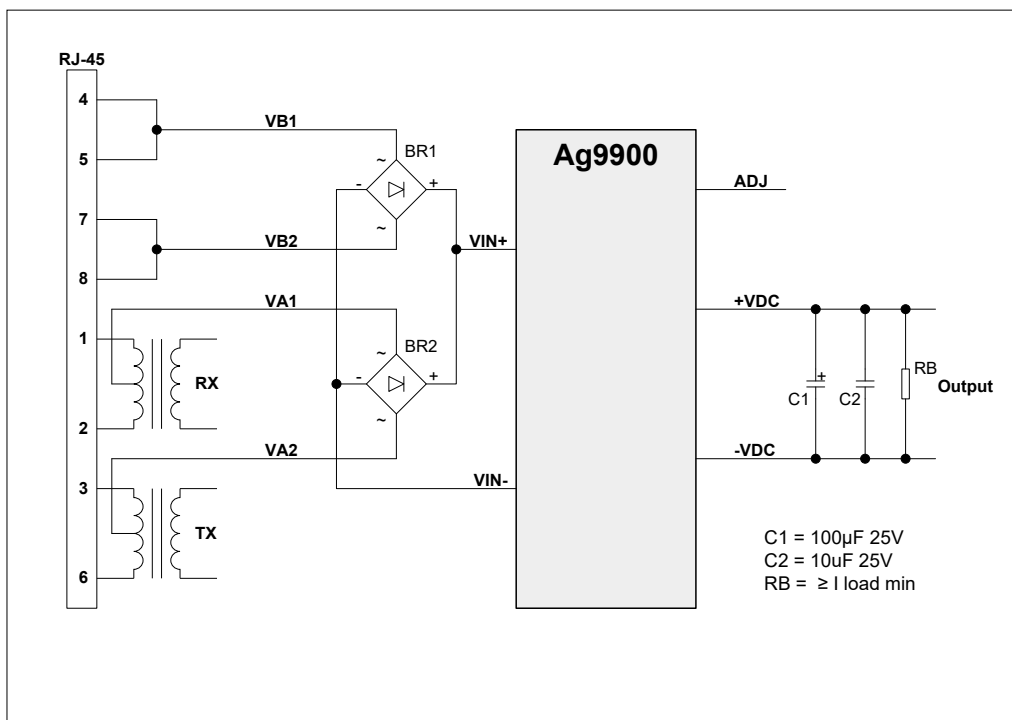

Figure 5: Typical Connection Diagram

The output adjust input (ADJ) is optional, it is provided to give greater flexibility to the Ag9900 product range. Further information on using these inputs can be found in Section 2.3.1 - Output Adjustment.

2.2 Input

The Ag9900 is compatible with equipment that uses Alternative A (power on data pair) or Alternative B (power on spare pair) options, see Figure 6.

It is recommended that the module be powered by an IEEE 802.3af compliant PSE or midspan equipment. However, the Ag9900 may be powered by a user designed power supply which should include thermal and over current protection and be current limited to 400mA.

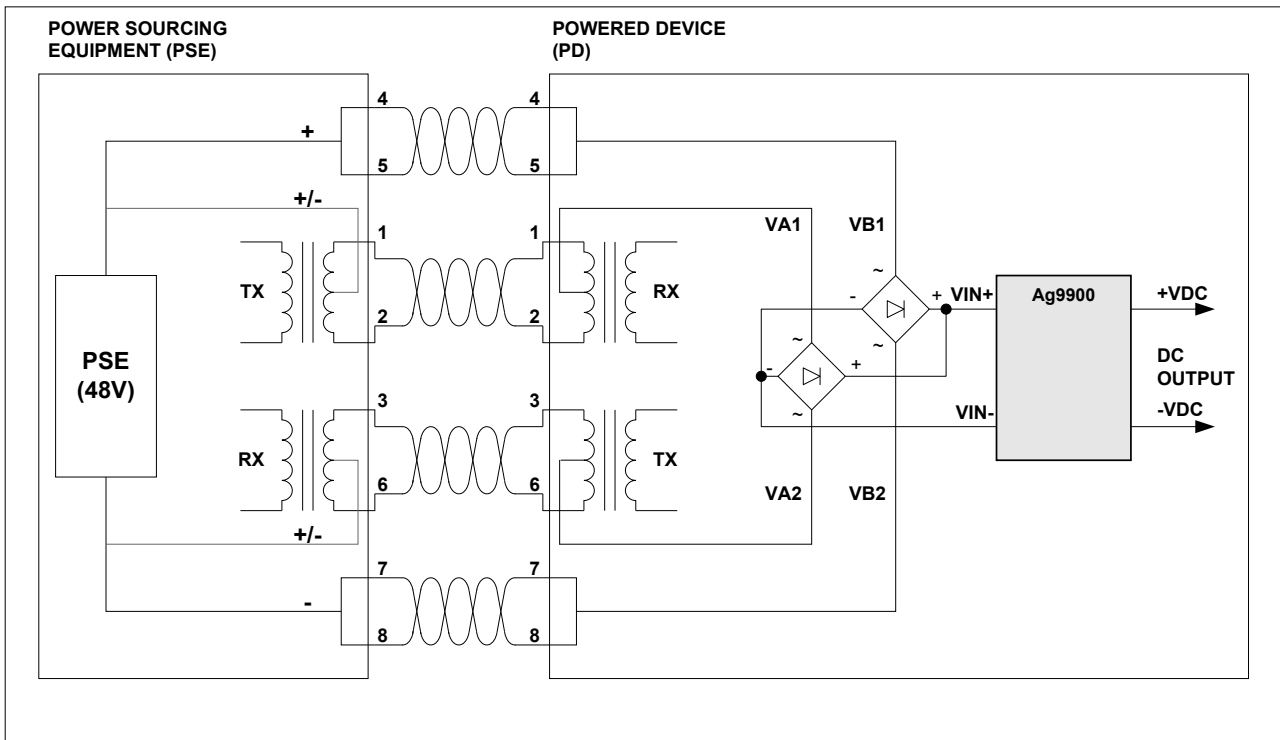

Figure 6: Typical System Diagram

2.2.1 PD Signature

When the Ag9900 is connected to the Cat5e cable, it will automatically present a Powered Device (PD) signature to the Power Sourcing Equipment (PSE) or Midspan Equipment, when requested. The equipment will then recognise that a powered device is connected to that line and supply power.

2.2.2 Power Classification

The Ag9900 is set to Class 0 (0.44 Watts to 12.95 Watts) operation.

2.2.3 Start-up Power

It is important that during start-up the Ag9900 input voltage is $\geq 42V$, this will ensure that the module powers up correctly. Once the dc/dc converter is up and running the module will work normally even if the input voltage is reduced to its minimum level of 36V.

When using an IEEE802.3af compliant PSE this will not be an issue, as the minimum output voltage of the PSE must be $\geq 44V$.

2.3 Output

The Ag9900's DC/DC converter provides a regulated output that has built-in short-circuit output protection – refer to Table 1: Ordering Information for voltage and power ratings.

2.3.1 Output Adjustment

The Ag9900 has an ADJ pin, which allows the output voltage to be increased or decreased from its nominal value. Figure 7 shows how the ADJ pin is connected.

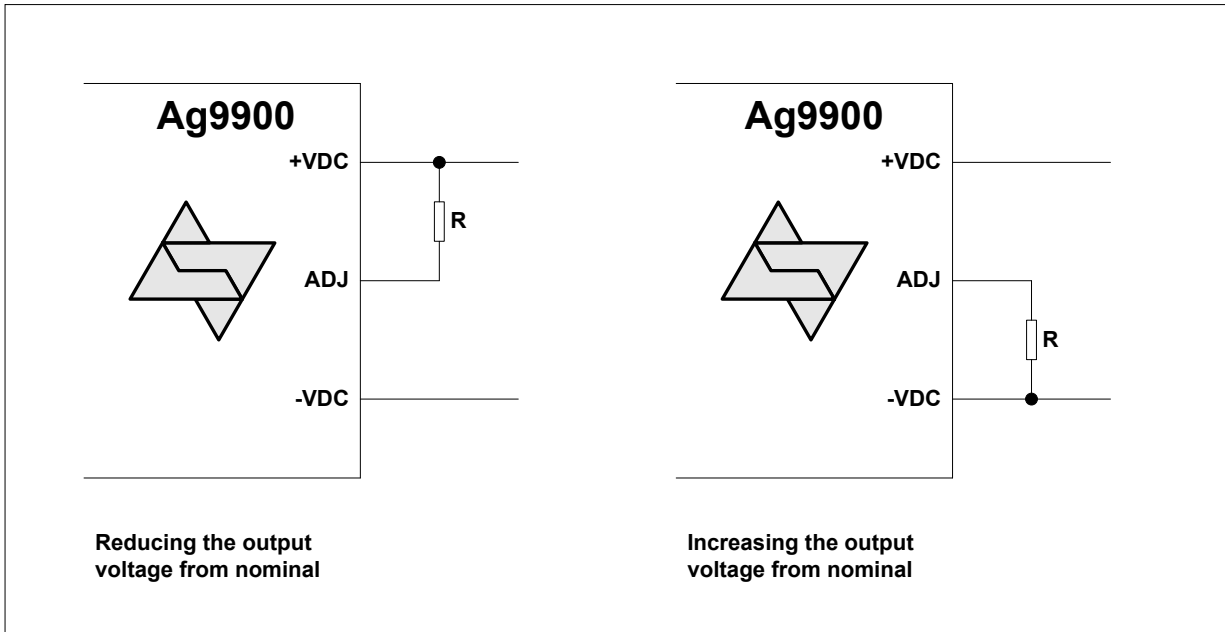

Figure 7: Output Adjustment

Reducing the output voltage, connect R between ADJ and +VDC				
Value of R	Ag9903 output	Ag9905 output	Ag9912 Output	Ag9924 Output
Open Circuit	3.30V	5.00V	12.00V	24.00V
0 Ohms	3.20V	4.48V	10.0V	19.85V
Increasing the output voltage, connect R between ADJ and -VDC				
Value of R	Ag9903 output	Ag9905 output	Ag9912 output	Ag9924 Output
Open Circuit	3.30V	5.00V	12.00V	24.00V
0 Ohms	3.78V	5.65V	12.75V	25.10V

Table 4: Output Adjustment Resistor (R) Value

2.3.2 Additional Output Filtering

The Ag9900 as shown in Figure 5 offers the minimum capacitance the customer must fit, however Figure 8 shows two cost effective methods for reducing the ripple and noise, if required.

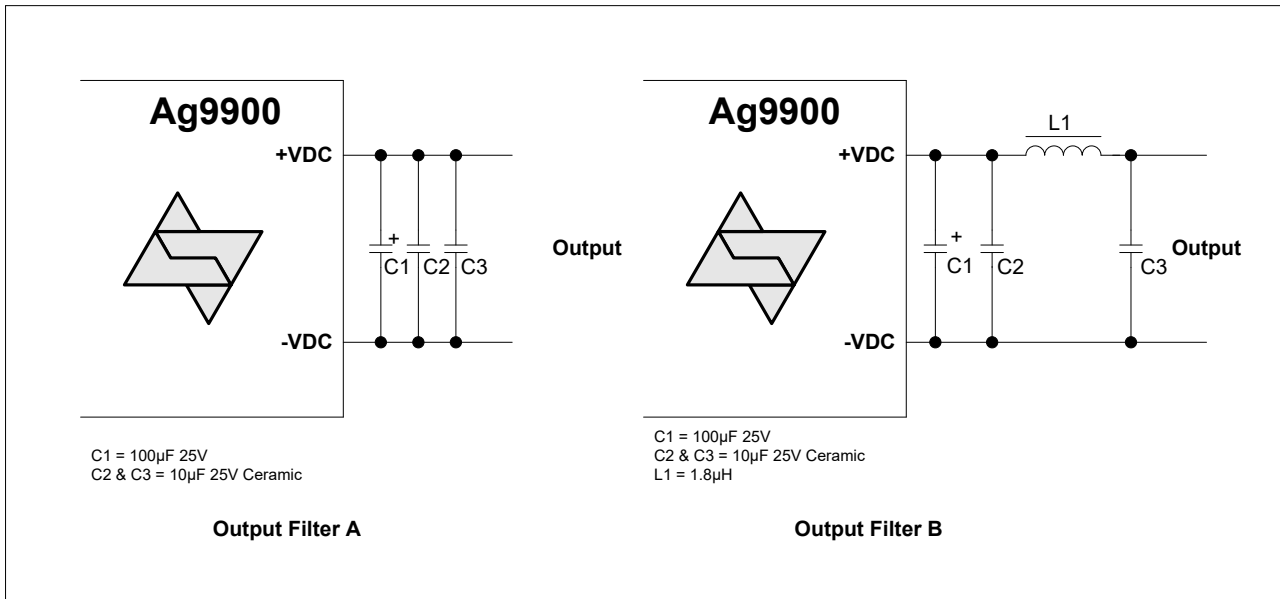

Figure 8: Output Filtering

The simplest and cheapest solution is shown in Figure 8 - Output Filter A. Taking the Ag9912-LPB as an example, this will reduce the ripple and noise to typically 142mVp-p at maximum load. Adding a PI filter, as shown in Figure 8 – Output Filter B, will take the ripple and noise level down further to typically 10mVp-p.

2.3.3 Minimum Load

The Ag9900 must always supply a minimum current; see Section 9.3 for more information. When operated below this level the Ag9900 will emit a low-level audible noise. The reason that the module emits this noise is due to the dc/dc converter running in discontinuous mode. See application note ANX-POE-Minimum-Load for more information.

If this audible noise is not an issue, then the Ag9900 can work safely with a much smaller load. But to ensure that the PSE has a sufficient load to meet its Maintain Power Signature (MPS), it would be advisable not to operate the Ag9900 below the specified minimum load.

3 Operating Temperature Range

Because the Ag9900 is a power component, it will generate heat, so it is important that this be taken into consideration at the design stage.

The heart of the Ag9900 is a DC/DC converter, which like any other power supply will generate heat. The amount of heat generated by the module will depend on the load it is required to drive, and the input voltage supplied by the PSE. The information shown within this section of datasheet is referenced to a nominal 48Vdc input voltage supplied by the PSE.

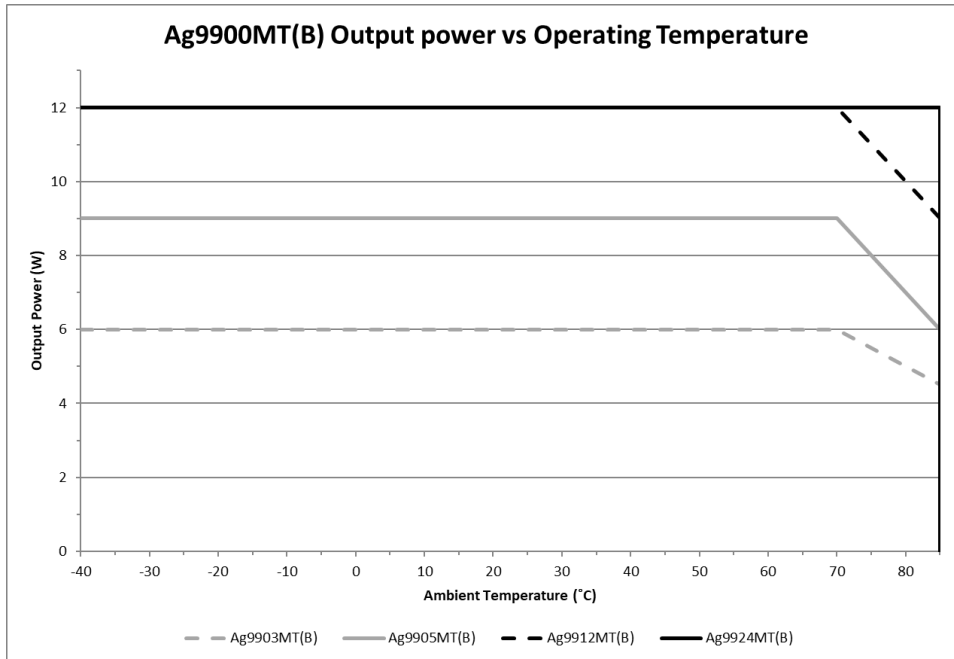

Figure 9: Ag9900-MT(B) Operating Profile

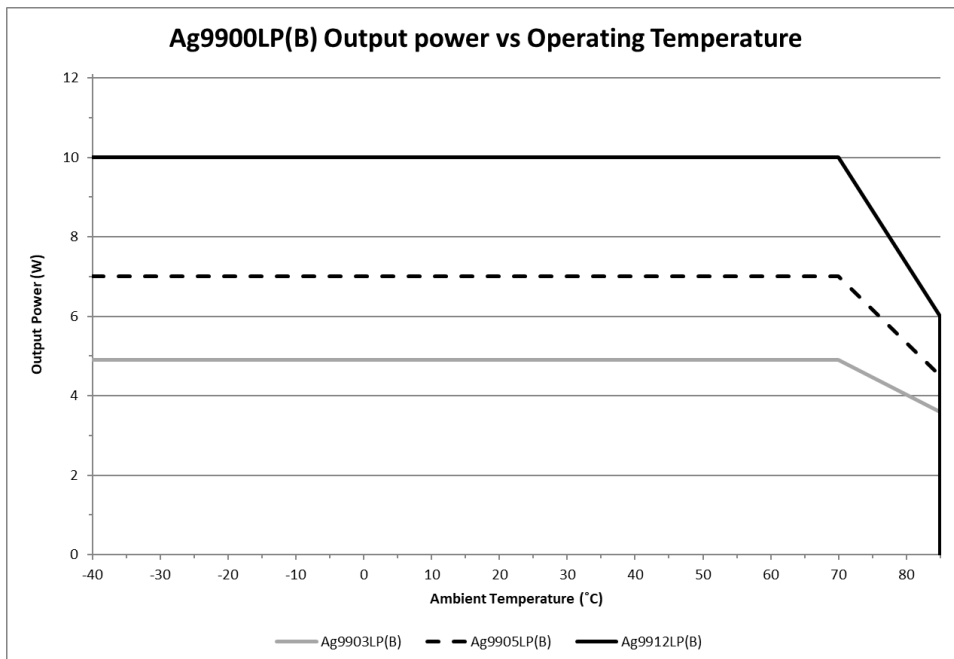

Figure 10: Ag9900-LP(B) Operating Profile

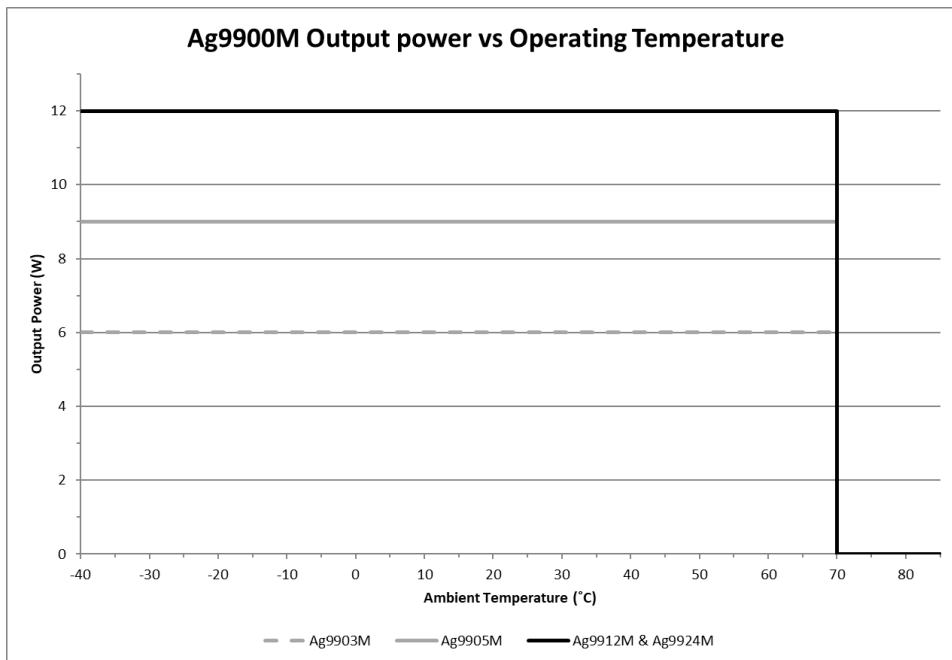

Figure 11: Ag9900-M Operating Profile

The industrial temperature variants of the Ag9900 are capable of operating in temperatures up to 85°C while heatsinking to a host PCB. While the standard temperature variants should only be operated in temperatures up to 70°C. see Figures 9 through 11 for power derating graphs.

These results were performed in an environment chamber - Associated Environmental System SD-302. The performance of the Ag9900 can be improved by forcing the airflow directly over the part, and by using a thermal gap filling gel, gap pad or paste. The customers PCB can then be thermally mounted (using a Bergquist 0.1" Ultra soft gap pad) to the chassis of the host equipment by using the thermal relief pads (see Figure 12 and application note "ANX-POE-Thermal-Considerations" for more information).

3.1 Thermal Considerations

Each application is different; therefore, it is impossible to give fixed and absolute thermal recommendations. Due to the small size of this module, it is important that as much heat as possible is drawn away from it. It is also important that any enclosure has sufficient ventilation for the Ag9900 and a direct airflow if possible.

One simple method for drawing some of the heat away from the Ag9900 is by means of power planes connected to the +VDC and -VDC pins of the Ag9900. This technique can be used to draw heat away from the DC/DC converter via the output pins.

These power planes must be on the outer layers of the PCB and the best results are achieved by having power planes on both sides of the main board with multiple through-hole connections. An example of this is shown in Figure 12.

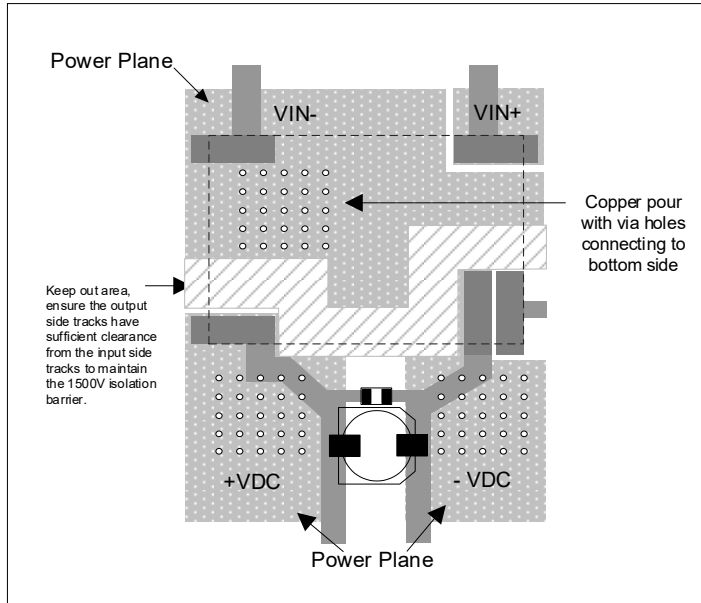

Figure 12: Ag9900 Thermal Relief

A method of drawing heat out of the module that we would recommend when using the Ag9900 series is the use of thermal gap filler gel placed underneath the Ag9900 PCB as shown below in Figure 13. The gap filler should fully encapsulate the components on the bottom side of the PCB with a thermal conductivity of greater than 1.5 W/m-K, such as Parker Chomerics THERM-A-GAP GEL, to provide the best possible thermal conduction through the material to the application PCB.

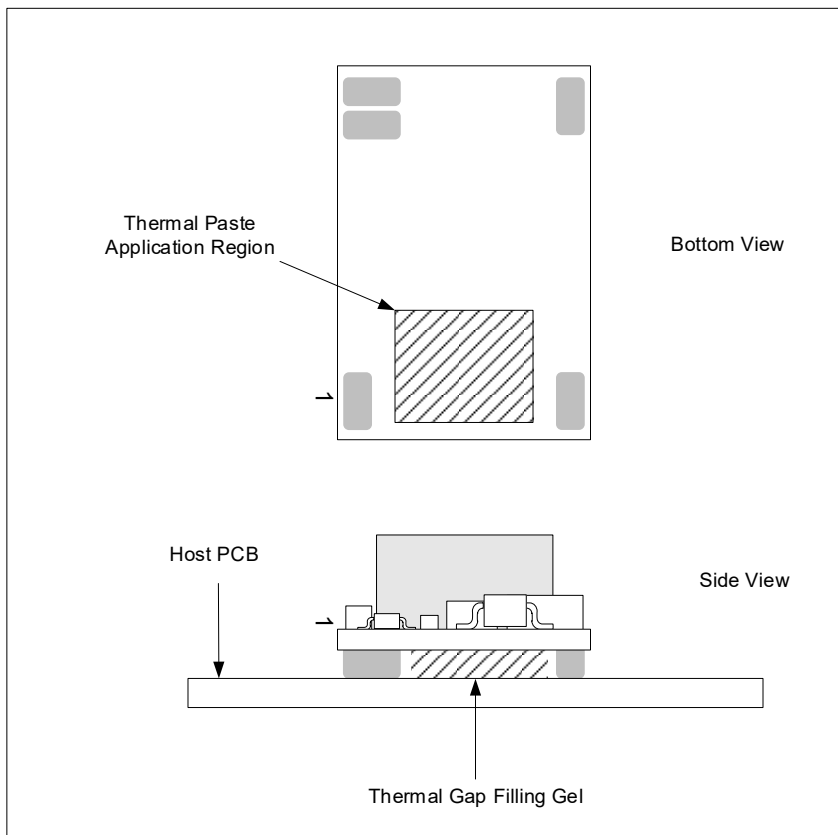

Figure 13: Thermal Paste Region

It is important to remember that the ESR of the external electrolytic capacitors will increase considerably when the ambient temperature falls below 0°C. If the Ag9900 is going to be used in applications where the ambient temperature can fall below 0°C, selection of appropriate output filter components must be done at the design stage.

4 Protection

4.1 Input Protection

The Ag9900 must be protected from over-voltages exceeding the 80V maximum rated surge input voltage. An inexpensive but effective solution can be achieved by connecting a tranzorb diode across the input; see Figure 14.

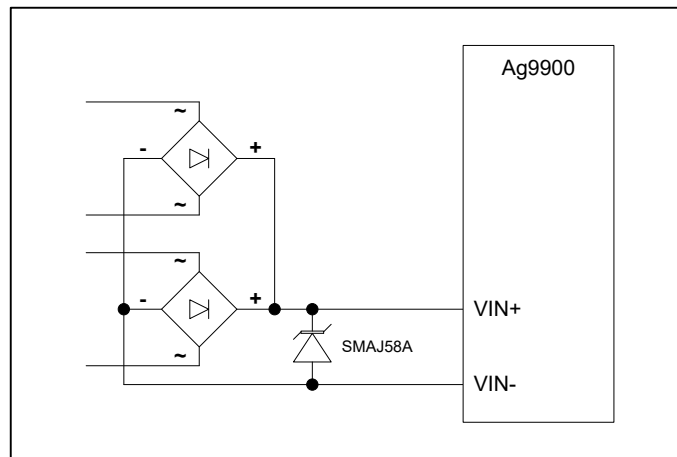

Figure 14: Ag9900 Input Protection

More information is available in Apps Note "ANX-POE-Protection".

4.2 Thermal Protection

The industrial temperature range variants of the Ag9900 feature built-in thermal protection, the standard temperature range variants do not. If the design is expected to operate in high ambient temperatures, >50°C, we would recommend the use of the equivalent industrial temperature variant.

The thermal protection present in the Ag9900 reduces the output power, see Figures 9 & 11, to ensure that the maximum component temperature is not exceeded. Full output power will be restored when the ambient temperature drops back down into the safe operating range.

5 Typical Application

The Ag9900 can be used in numerous applications. In the example shown in Figure 15, the data outputs from the switch are connected to the inputs of a midspan. The midspan will then add power (to the data) on each output that supports Power over Ethernet (PoE).

In this example port 1 is connected to an Ethernet camera and port 2 is connected to a wireless access point, both of these devices have a built-in Ag9900. When the midspan is switched on (or when the device is connected), the midspan will check each output for a PoE signature. On ports 1 and 2 the Ag9900 will identify themselves as PoE enabled devices and the midspan will supply both data and power to these peripherals.

The other ports (shown in this example) will not have a PoE signature and the midspan will only pass the data through to these peripherals. The midspan will continuously monitor each output to see if a PoE enabled device has been added or removed.

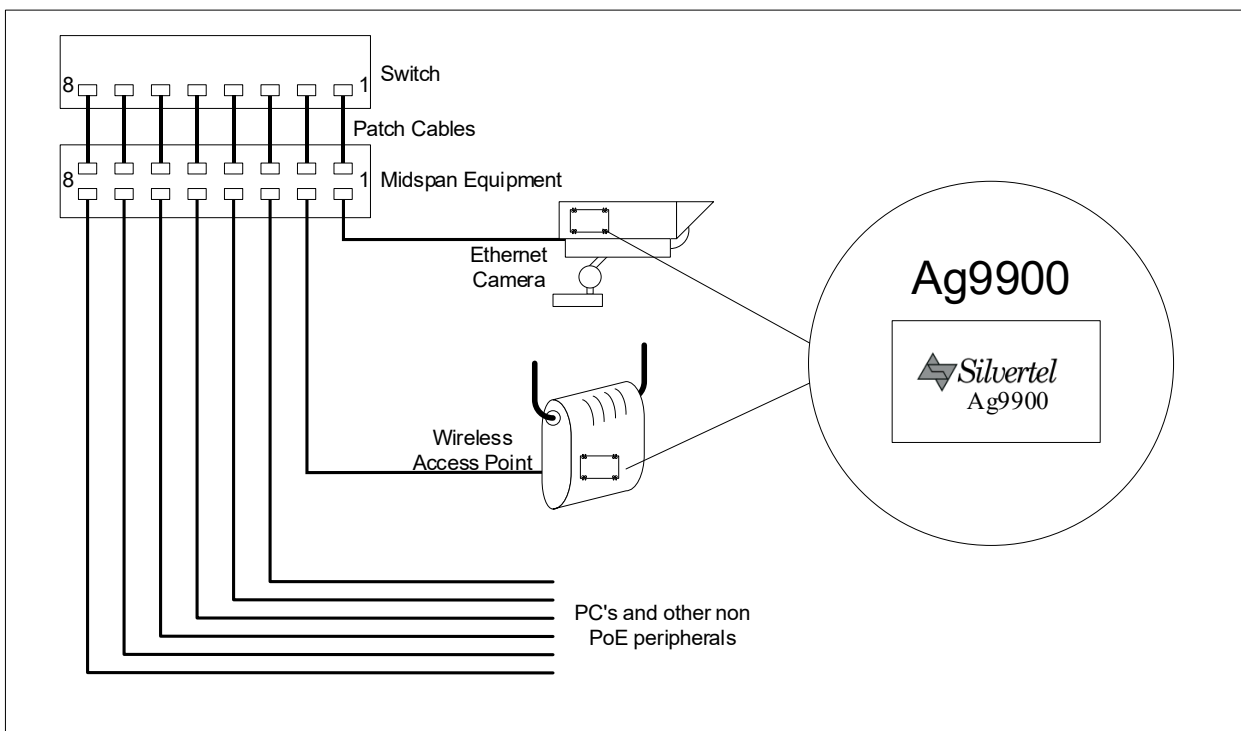

Figure 15: Typical Application

6 Isolation

To meet the safety isolation requirements of IEEE802.3af section 33.4.1 a Powered Device (PD) must pass the electrical strength test of IEC 60950 sub clause 6.2. This calls for either a) 1500Vac test or b) 1500Vdc impulse test. The Ag9900 is specified to meet the 1500Vdc impulse test. It is also important that the tracks on either side of the isolation barrier have at least a 3mm clearance.

Figures 21 through 24 show the location and size of the isolation barrier. This area must be kept clear of tracks to adhere to the isolation requirements.

7 EMC

The Ag9900 uses a dc/dc converter with pulse width modulation, so care does need to be taken to minimise emissions.

The Ag9900 is designed to meet EN55032 Class B (pre-compliance test results are available from Silvertel) however, because the Ag9900 will only be one component within your system, it is impossible to say whether the final product will pass EMC testing without the need for additional filtering. Figure 16 shows our recommended EMC Filter configuration for the Ag9900. For more information, tips and suggestions refer to the application note “ANX-POE-EMI” on our website.

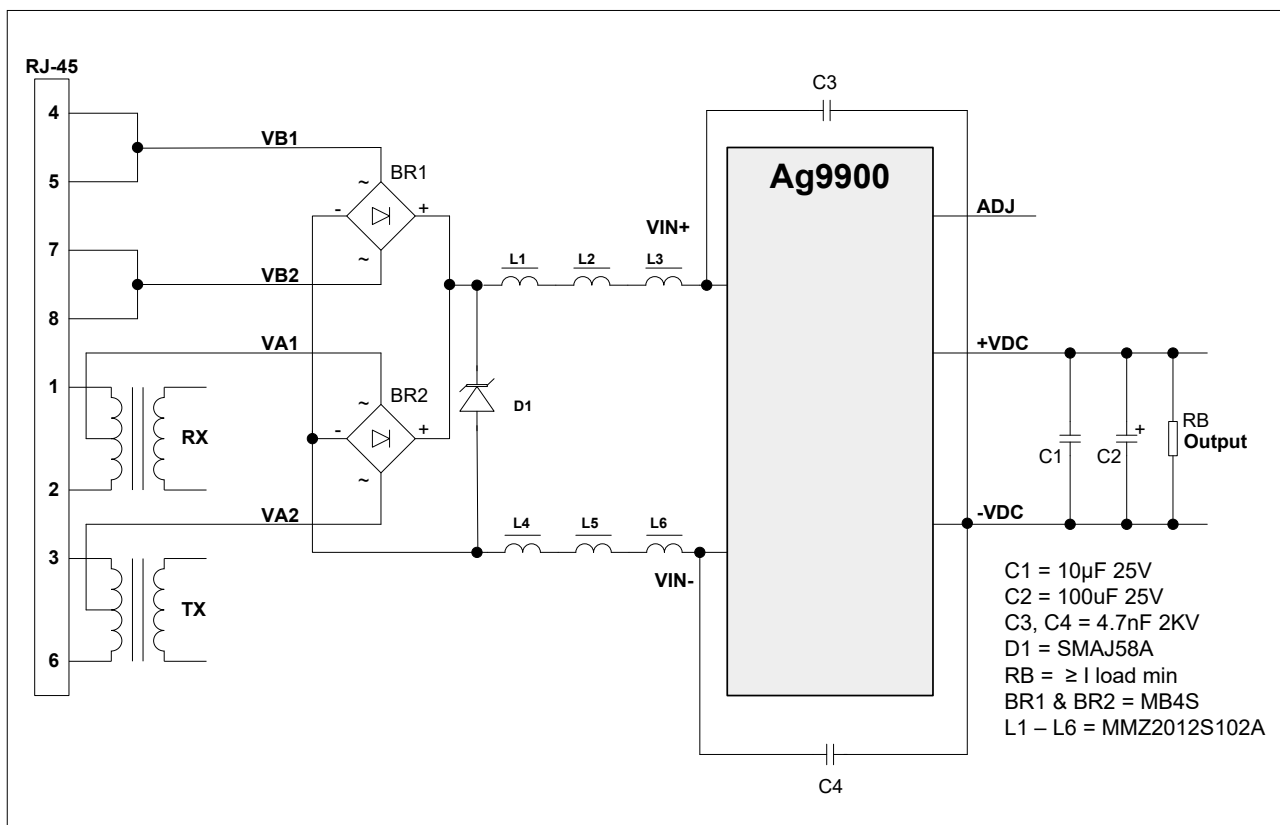

Figure 16: EMC Filtering

8 Solderability

The Ag9900 is lead-free (Pb-free) and RoHS compliant and fully compatible in a Pb-free soldering process.

The low profile DIL variants are only suitable for hand and wave soldering, the soldering specification is available upon request. All other variants are suitable for reflow using the below reflow profile.

There are no specific requirements regarding stencil thickness or solder paste classification type. Solder mask defined (SMD) pads are preferred over non-solder mask defined (NSMD) pads, the land pattern dimensions are given in Figures 21 through 23

Minimal thermal relief should be applied to the pads to allow for maximum thermal conductivity without hindering the reflow process, your Process Engineer should be able to provide suitable recommendations.

The Ag9900 requires no components of greater than Moisture Sensitivity level 1, as a result no special processes are required in the reflowing process of the Ag9900.

Note : Do not pass the Ag9900 through the reflow process mounted to the underside of the assembly due to the risk of components falling off the module.

8.1 Solder Profile

Below is a typical profile that the Ag9900 should be mounted, based on the J-STD-020 standard for Pb-Free applications. Exceeding these specifications may cause damage to the module. All production environments are different therefore please review these guidelines with the process engineer prior to use.

	Zone 1	Zone 2	Zone 3	Zone 4	Zone 5	Units
Zone Duration	42	42	42	42	42	Seconds
Top Heater	150	180	210	240	270	°C
Bottom Heater	150	180	210	240	270	°C
Typical Slope	2.1	1.2	1.1	0.9	0.8	°C/Second
Airflow rate	40					M ³ /Minute

Table 5: Solder Profile

	Min	Max	Units
Soak Time (s) 150-180°C	30	90	Seconds
Time above (s) ≥217°C	30	90	Seconds
Time within 5°C of peak Temperature		30	Seconds
Target Peak Temperature (°C)	230	245	°C
ΔTemperature (°C/s)	-6	3	°C/Second

Table 6: Solder Parameters

9 Electrical Characteristics

9.1 Absolute Maximum Ratings¹

	Parameter	Symbol	Min	Max	Units
1	DC Supply Voltage	V _{CC}	-0.3	60	V
2	DC Supply Voltage Surge for 1ms	V _{SURGE}	-0.6	80	V
3	Storage Temperature	T _S	-40	+100	°C
4	Moisture Sensitivity Level	MSL	-	1	-

Note 1: Exceeding the above ratings may cause permanent damage to the product. Functional operation under these conditions is not implied. Maximum ratings assume free airflow.

9.2 Recommended Operating Conditions

	Parameter	Symbol	Min	Typ	Max	Units	
1	Input Supply Voltage ¹	V _{IN}	36	48	57	V	
2	Under Voltage Lockout	V _{LOCK}	30		36	V	
3	Operating Temperature Range ²	Standard	T _{OP}	-40	25	70	T _a / °C
		Industrial				85	

Note 1: With minimum load

Note 2: See Table 1: Ordering Information and Section 3: Operating Temperature Range

9.3 DC Electrical Characteristics

	DC Characteristic	Variant	Sym	Min	Typ ¹	Max	Units
1	Nominal Output Voltage	Ag9924	+VDC	23.3	24	24.8	V
		Ag9912		11.5	12	12.5	
		Ag9905		4.75	5	5.25	
		Ag9903		3.1	3.3	3.5	
2	Minimum Load ²	Ag9924	I _{LOAD}	50			mA
		Ag9912		100			
		Ag9905		200			
		Ag9903					
3	Maximum continuous Output Current (VIN = 48V)	Ag9924-M/MT/MTB	I _{out}			0.5	A
		Ag9912-M/MT/MTB				1.0	
		Ag9905-M/MT/MTB				1.8	
		Ag9903-M/MT/MTB				1.8	
		Ag9912-LP/LPB				0.8	
		Ag9905-LP/LPB				1.4	
		Ag9903-LP/LPB				1.5	
4	Line Regulation	Ag9924-MTB	V _{LINE}		0.14		%
		Ag9912-M/MT/MTB			0.02		
		Ag9905-M/MT/MTB			0.05		
		Ag9903-M/MT/MTB			0.05		
		Ag9912-LP/LPB			0.02		
		Ag9905-LP/LPB			0.01		
		Ag9903-LP/LPB			0.01		
5	Load Regulation – Min to Max (VIN = 48V)	Ag9924-M/MT/MTB	V _{LOAD}		0.12		%
		Ag9912-M/MT/ MTB			0.1		
		Ag9905-M/MT/MTB			0.12		
		Ag9903-M/MT/MTB			0.7		
		Ag9912-LP/LPB			0.05		
		Ag9905-LP/LPB			0.08		
		Ag9903-LP/LPB			0.09		
6	Output Ripple and Noise ⁴ @ Max load	Ag9924-M/MT/MTB Ag9912-M/MT/MTB	V _{RN}		125 120		mV _{p-p}

	DC Characteristic	Variant	Sym	Min	Typ ¹	Max	Units
		Ag9905-M/MT/MTB			95		
		Ag9903-M/MT/MTB			78		
		Ag9912-LP/LPB			142		
		Ag9905-LP/LPB			120		
		Ag9903-LP/LPB			45		
7	Peak Efficiency	Ag9924-M/MT/MTB	EFF		87		%
		Ag9912-M/MT/MTB			87		
		Ag9905-M/MT/MTB			83		
		Ag9903-M/MT/MTB			80		
		Ag9912-LP/LPB			86		
		Ag9905-LP/LPB			83		
		Ag9903-LP/LPB			80		
8	Short-Circuit Duration ⁵		T _{SC}			∞	sec
9	Isolation Voltage (I/O) - Impulse Test		V _{ISO}			1500	V _{PK}

Note 1: Typical figures are at 25°C with a nominal 48V supply and are for design aid only. Not Guaranteed

Note 2: The module can emit an audible noise, if operated at less than the stated minimum I_{LOAD} and cause the PSE to fail its MPS.

Note 3: The Ag9912 output must not exceed 12W.

Note 4: Measured with external filter A. The output ripple and noise can be reduced further with external filter B, see Section 2.3.2.

Note 5: >200mohm short due to thermal limitation.

10 Package Dimensions

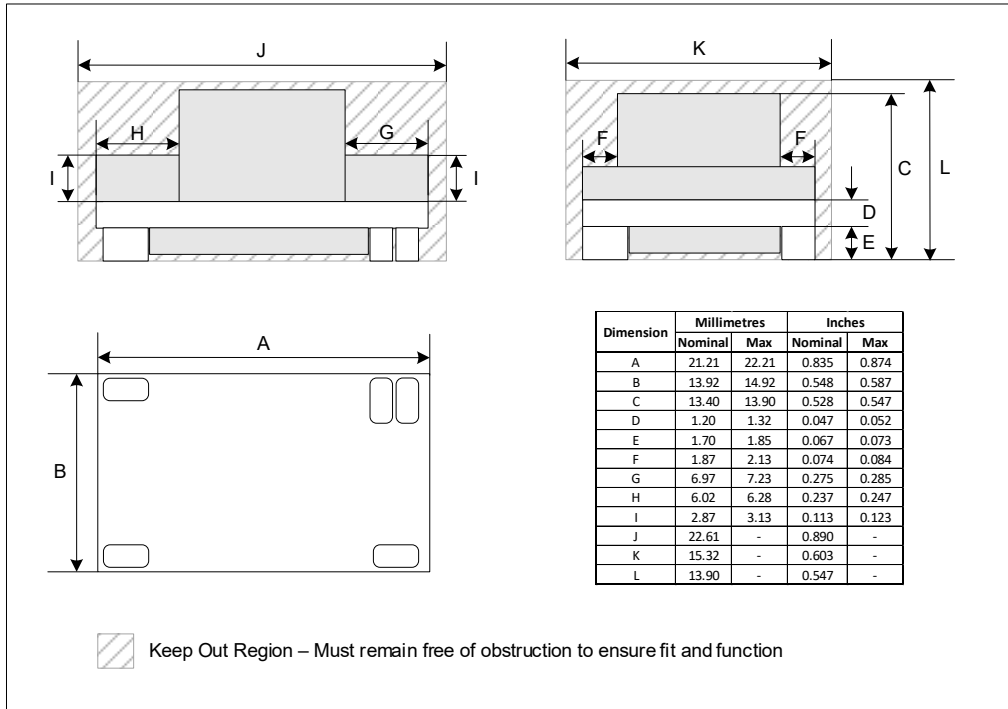

Figure 17: Ag9900-MTB Package Dimensions

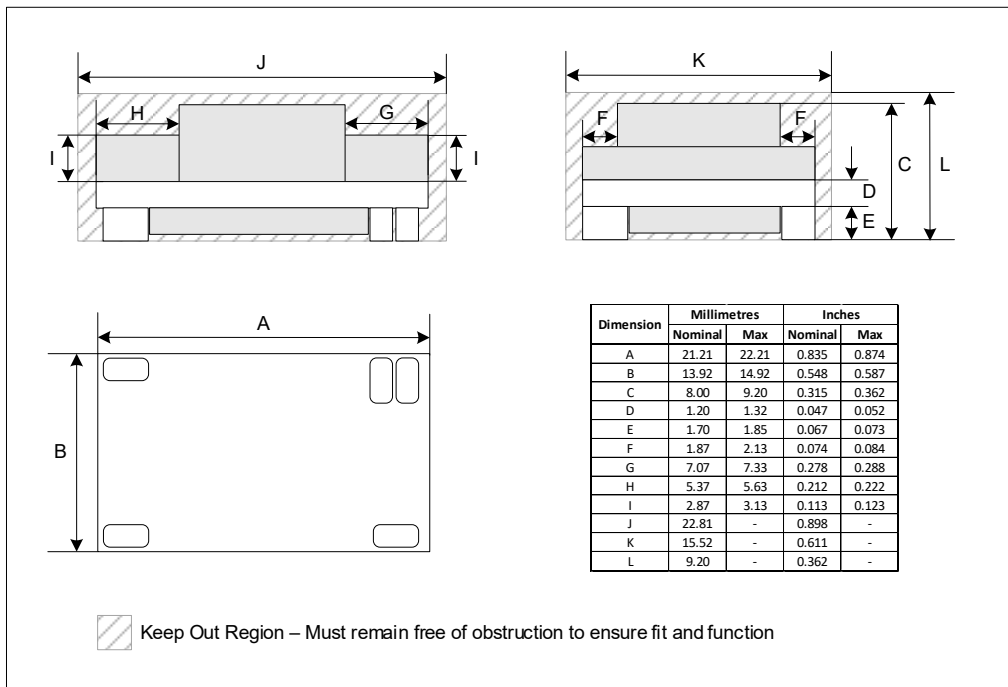

Figure 18: Ag9900-LPB Package Dimensions

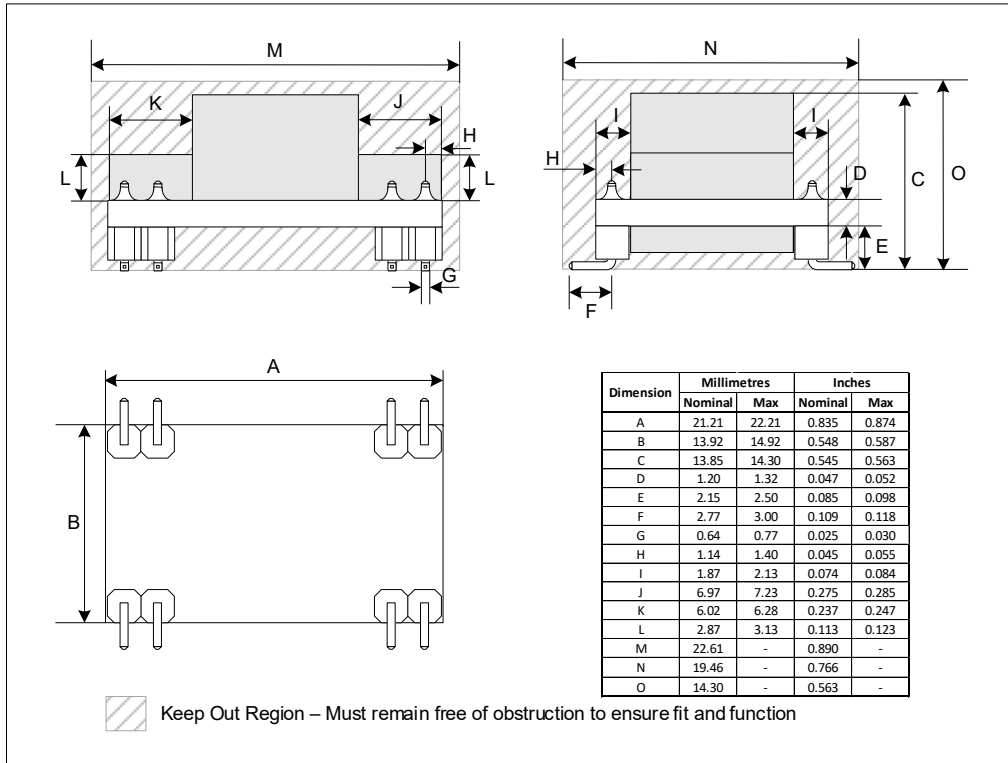

Figure 19: Ag9900-M(T) Package Dimensions

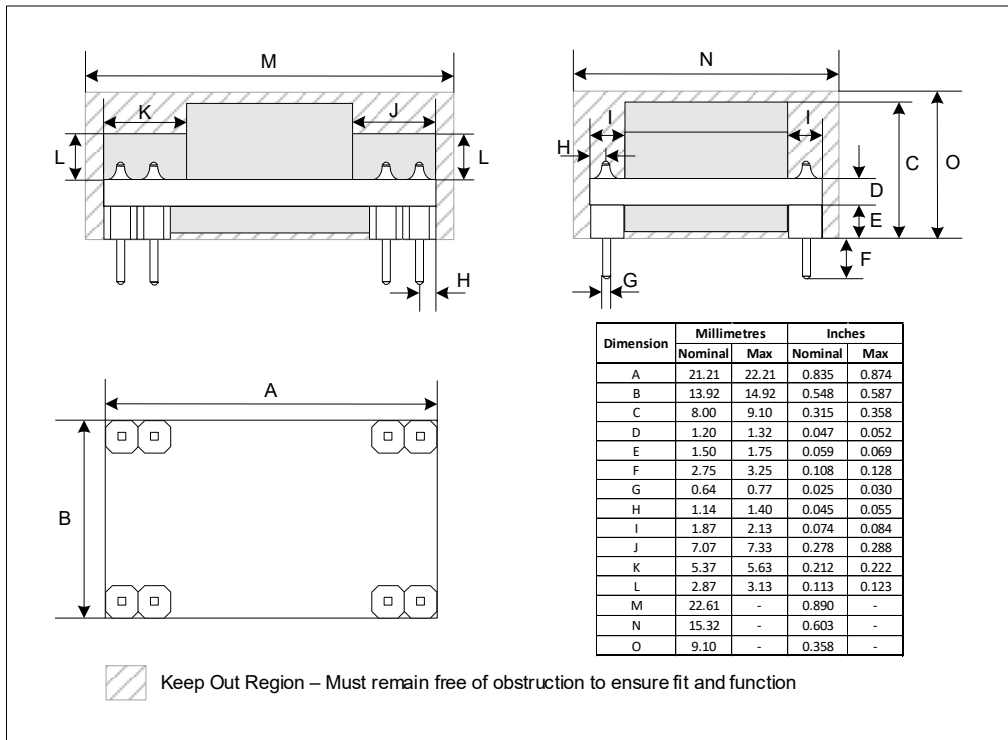

Figure 20: Ag9900-LP Package Dimensions

11 Land Patterns

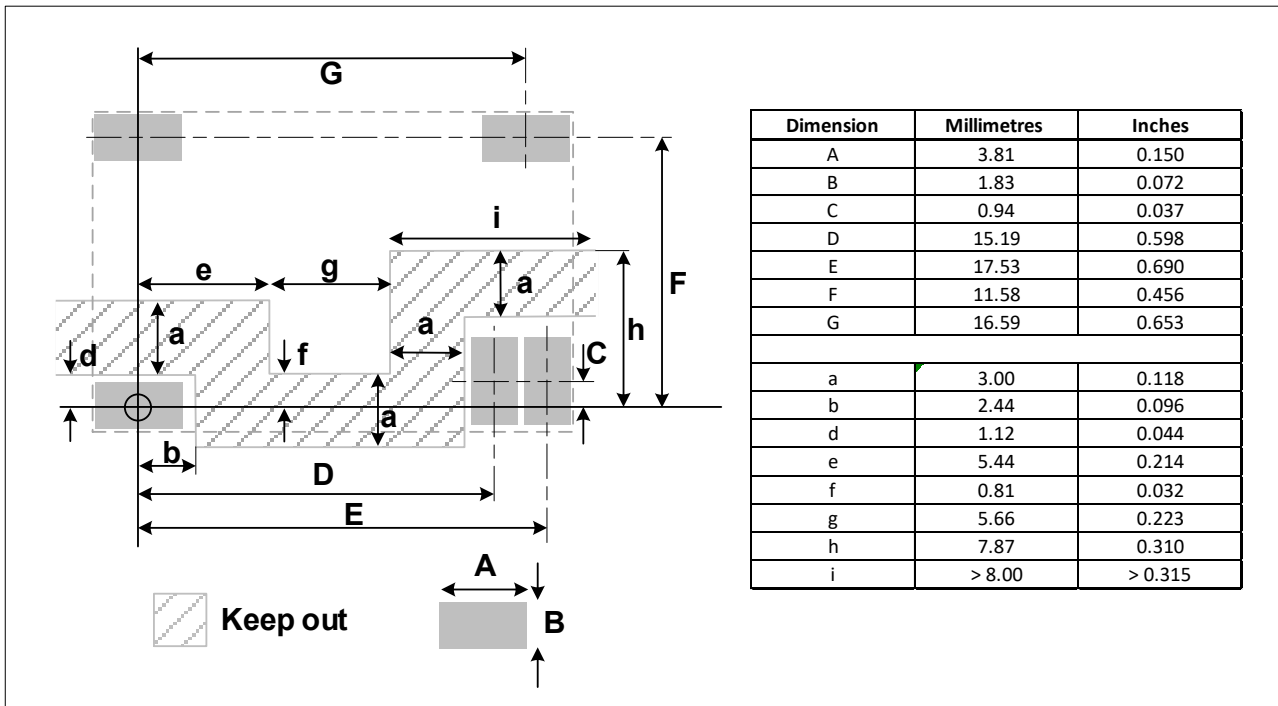

Figure 21: Ag9900-MTB and Ag9900-LPB Variant Reflow Land Pattern

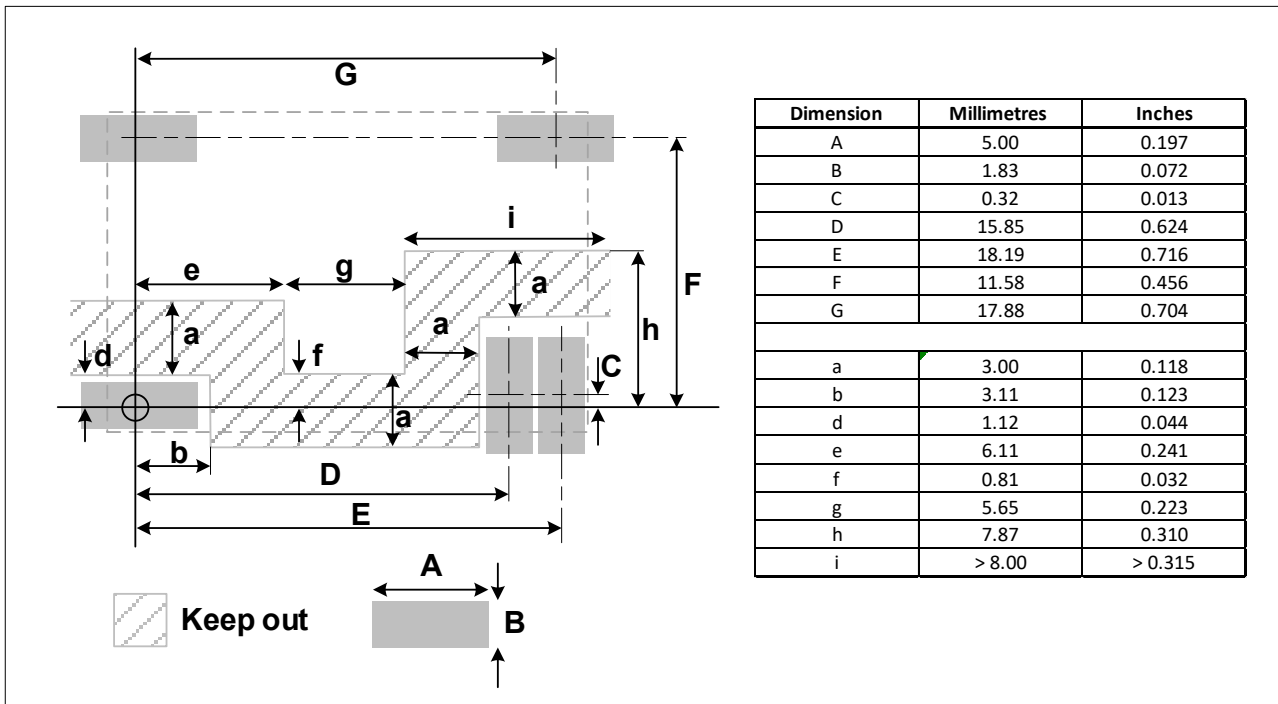

Figure 22: Ag9900-MTB and Ag9900-LPB Variant Hand Soldering Land Pattern

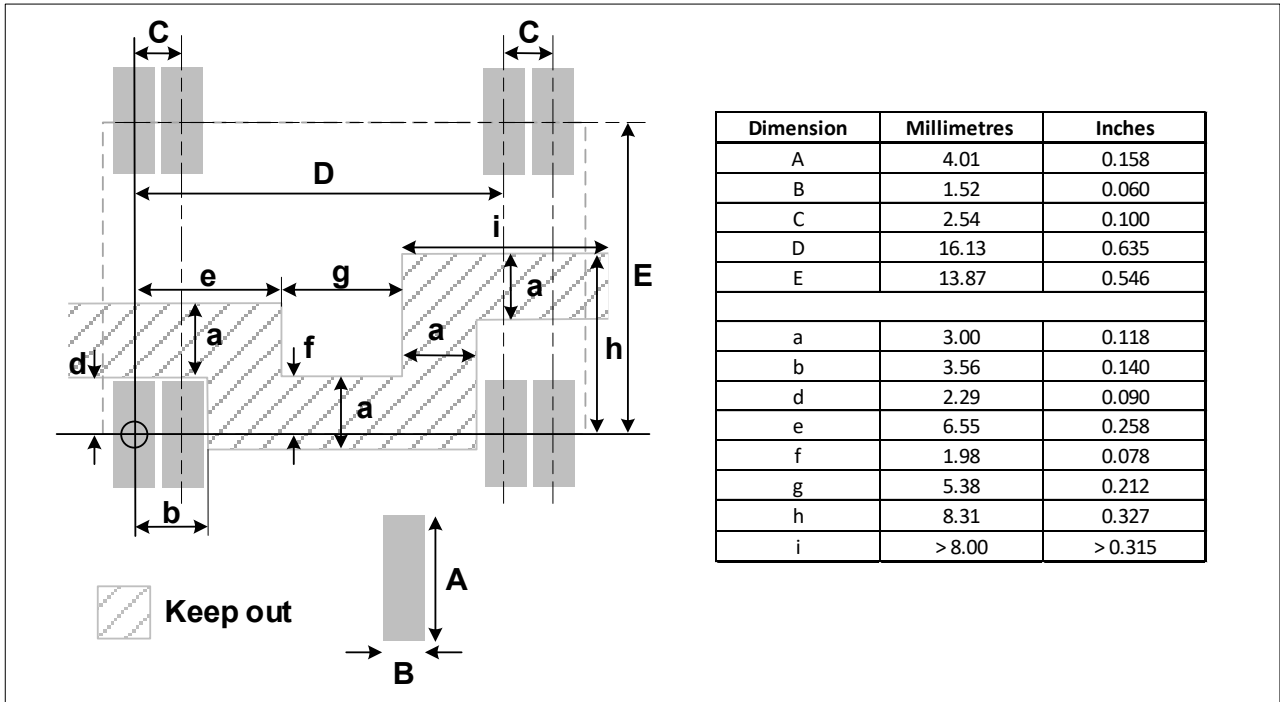

Figure 23: Gull Wing SMT Variant Land Pattern

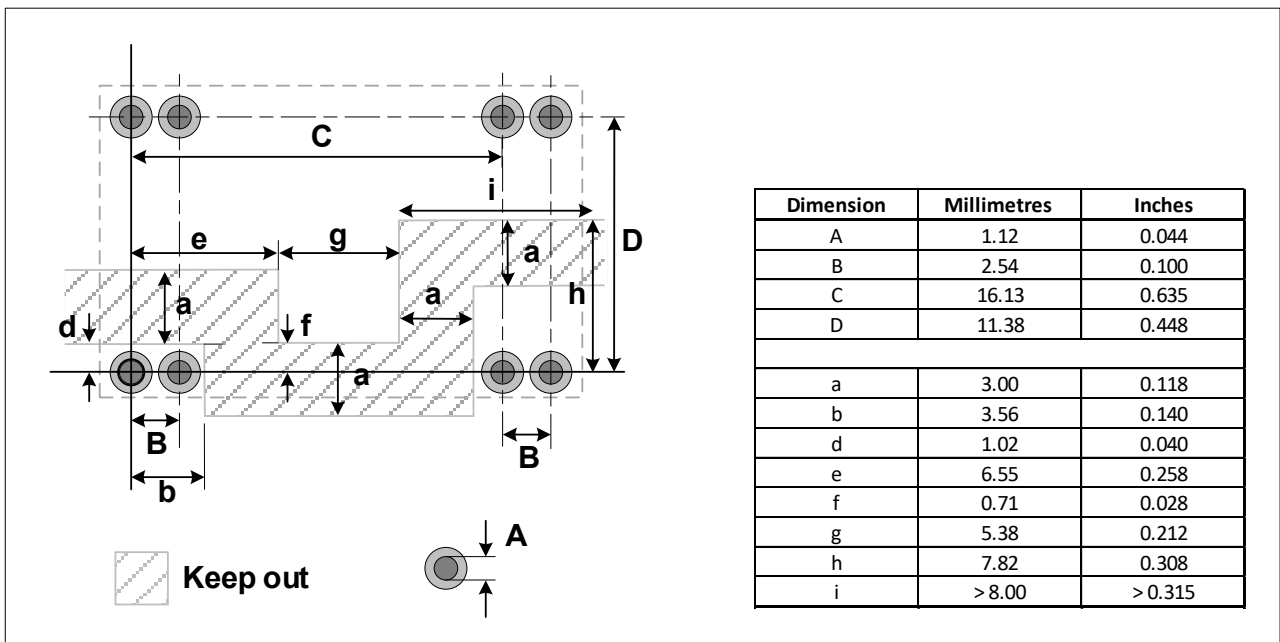
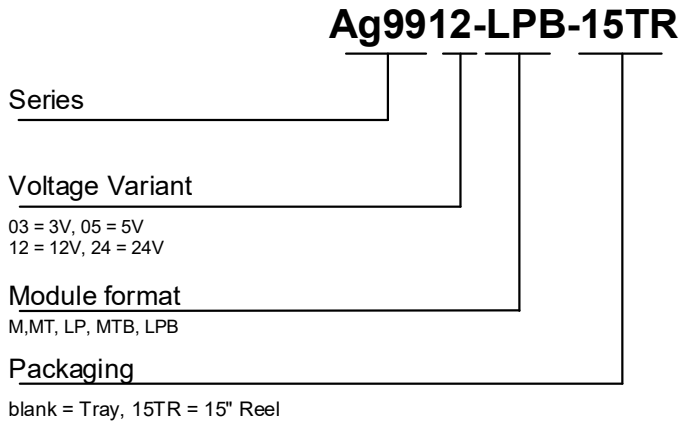

Figure 24: Low Profile DIL Variant Land Pattern

12 Ordering Code



13 Packaging

The default packing for the Ag9900 series is supplied in trays of 100. There is the option for the Ag9900-LPB and the Ag9900-MTB variants to be packaged on a 15 inch reel.

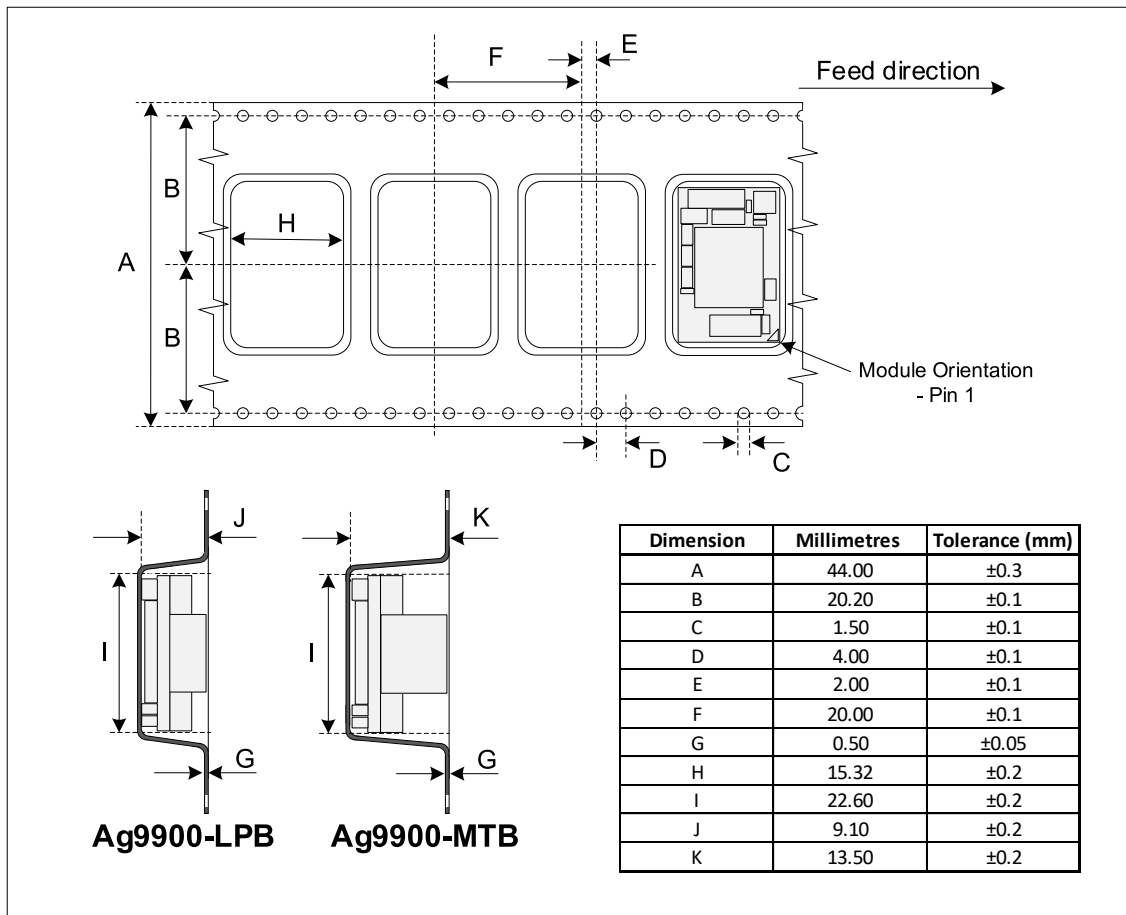

Figure 25: Tape Dimensions

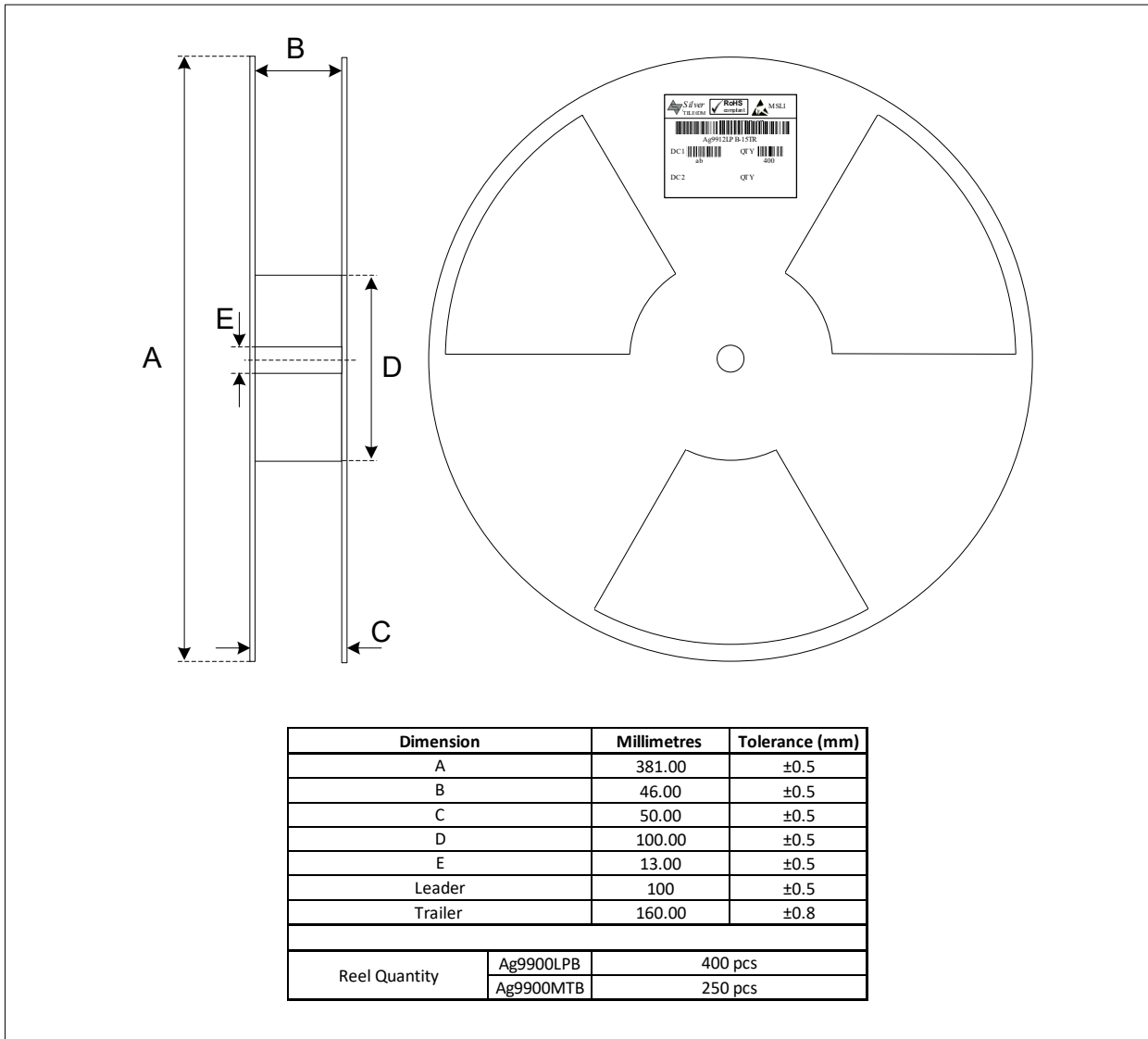

Figure 26: Reel Dimensions

The latest revision of all application notes referenced in this document can be found on the Silver Telecom website” www.silvertel.com”.

Information published in this datasheet is believed to be correct and accurate. Silver Telecom assumes no liability for errors which may occur or for liability otherwise arising out of use of this information or infringement of patents which may occur as a result of such use. No license is granted by this document under patents owned by Silver Telecom or licensed from third parties by Silver Telecom. The products, their specification and information appearing in this document are subject to change by Silver Telecom without notice.