



SD50 Wireless Status Display

Original Instructions

p/n: 248525 Rev. B

13-Feb-26

© Banner Engineering Corp. All rights reserved. www.bannerengineering.com

Contents

Chapter 1 Features	3
Models	3
Wiring.....	3
Specifications	3
FCC Part 15 Class A for Intentional Radiators.....	4
Industry Canada Statement for Intentional Radiators.....	4
Dimensions	5
Chapter 2 Configuration Instructions	6
R70 Buttons and LEDs.....	6
Set the R70SR DIP Switches.....	6
Bind the SD50 to the R70.....	7
Chapter 3 Modbus Register Map	8
Holding Register Column Definitions.....	8
Modbus Configuration	8
Device Information.....	9
Operation Mode.....	9
Run Mode	10
Message Mode	11
Level Mode	15
Timer Mode.....	26
Counter Mode.....	37
Display Settings.....	48
Custom Settings	49
Custom Color 1 Configuration	49
Custom Color 2 Configuration	49
Restore Factory Defaults.....	50
Chapter 4 Product Support and Maintenance	51
Accessories	51
Controllers and Radios	51
Cordsets.....	51
Mounting Brackets	52
Encoding Table and Unicode Characters	52
Clean with Mild Detergent and Warm Water	57
Repairs	57
Contact Us.....	57
Banner Engineering Corp Limited Warranty.....	57

Chapter Contents

Models 3
 Wiring 3
 Specifications 3

Chapter 1 Features

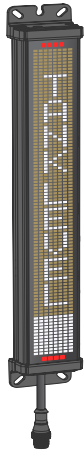

- Easily configurable, versatile display can be installed nearly anywhere, making it a simple yet powerful alternative to complex HMIs and other displays
- Great for displaying takt time, equipment status, assembly sequences, counts, and measurements where they are most useful
- Quick and easy configuration—simply define the desired text and call it via Modbus control
- Bright white LED display and multicolored status LEDs legible from 10 meters away inform operators about exactly what is going on so they can respond quickly and accurately
- IP65-rated polycarbonate housing resists impact and condensation to provide clear communication in challenging and changing environmental conditions
- Quick and easy configuration wirelessly using Modbus control
- Integral 900 MHz or 2.4 GHz serial data radio

Models

Models	Radio Frequency	Connector
SD50P300WSR9QP	900 MHz serial data radio	150 mm (6 in) PVC-jacketed cable with a 4-pin M12 male quick disconnect connector
SD50P300WSR2QP	2.4 GHz serial data radio	

See ["Accessories" on page 51](#) for a list of the DXM Controllers and R70SR SNAP SIGNAL Serial Data Radios Banner Engineering Corp recommends using with this product.

Wiring

Modbus Wiring

4-Pin Male M12 Pinout	Pinout Key and Wiring
	<ol style="list-style-type: none"> 1. Brown - 12 V DC to 30 V DC 2. White - RS-485 (+) 3. Blue - DC Common 4. Black - RS-485 (-)

Specifications

Supply Voltage

12 V DC to 30 V DC

Use only with a suitable Class 2 power supply (UL) or SELV power supply (CE)

Supply Current for 900 MHz

830 mA maximum at 12 V DC

400 mA maximum at 24 V DC

330 mA maximum at 30 V DC

Supply Current for 2.4 GHz

570 mA maximum at 12 V DC
 280 mA maximum at 24 V DC
 230 mA maximum at 30 V DC

Connections

150 mm (6 in) PVC-jacketed cable with a 4-pin M12 male quick-disconnect connector

Models with a quick-disconnect connector require a mating cordset

Do not spray the cable with a high-pressure sprayer or cable damage will result

Operating Temperature

-20 °C to +50 °C (-4 °F to +122 °F)

Storage Temperature

-40 °C to +70 °C (-40 °F to +158 °F)

Environmental Rating

Rated IP65

Suitable for damp locations per UL 2108

Vibration and Mechanical Shock

Meets IEC 60068-2-6 requirements (Vibration: 10 Hz to 55 Hz, 1.0 mm amplitude, 5 minutes sweep, 30 minutes dwell)

Meets IEC 60068-2-27 requirements (Shock: 15G 11 ms duration, half sine wave)

Construction

Black polycarbonate housing and end caps

Internal silicone-encapsulated LEDs

Smoky polycarbonate window

Radio Range

A 1 dB antenna is embedded within this device.

Transmit power and range are subject to many factors, including antenna gain, installation methods, characteristics of the application, and environmental conditions.

Please refer to the following documents for installation instructions and high-gain antenna options.

Installing Your Sure Cross® Radios ([151514](#))
 Conducting a Site Survey ([133602](#))
 Sure Cross® Antenna Basics ([132113](#))

Antenna Minimum Separation Distance

900 MHz radios transmitting at ≥ 500 mW: 4.57 m (15 ft) with the supplied antenna

2.4 GHz radios transmitting at 65 mW: 0.3 m (1 ft) with the supplied antenna

Radio Transmit Power

900 MHz Conducted: 27 dBm (500 mW); EIRP with the supplied antenna: < 36 dBm

2.4 GHz Conducted: < 18 dBm (65 mW); EIRP with the supplied antenna: < 20 dBm (100 mW)

Spread Spectrum Technology

FHSS (Frequency Hopping Spread Spectrum)

Character Limit

Run Mode: 29 characters

All other Modes: 32 characters

Required Overcurrent Protection

WARNING: Electrical connections must be made by qualified personnel in accordance with local and national electrical codes and regulations.

Overcurrent protection is required to be provided by end product application per the supplied table.

Overcurrent protection may be provided with external fusing or via Current Limiting, Class 2 Power Supply.

Supply wiring leads < 24 AWG shall not be spliced.

For additional product support, go to www.bannerengineering.com.

Supply Wiring (AWG)	Required Overcurrent Protection (A)	Supply Wiring (AWG)	Required Overcurrent Protection (A)
20	5.0	26	1.0
22	3.0	28	0.8
24	2.0	30	0.5

Mounting

M5 and 1/4-20 compatible end caps (not included)

Clip brackets for mounting are available

900 MHz Compliance (SX7023EXT Radio Module)

Radio module is indicated by the product label marking

Contains FCC ID: UE3SX7023EXT

Contains IC: 7044A-SX7023EXT

2.4 GHz Compliance (SX243 Radio Module)

Radio module is indicated by the product label marking

Contains FCC ID: UE3SX243

Radio Equipment Directive (RED) 2014/53/EU

Contains IC: 7044A-SX243

Radio Data Transfer Rate

900 MHz: 300 kbps

2.4 GHz: 250 kbps

Certifications

CE/UKCA approval only applies to 2.4 GHz models



Banner Engineering BV
 Park Lane, Culliganlaan 2F bus 3
 1831 Diegem, BELGIUM



FCC Part 15 Class A for Intentional Radiators

This equipment has been tested and found to comply with the limits for a Class A digital device, pursuant to Part 15 of the FCC Rules. These limits are designed to provide reasonable protection against harmful interference when the equipment is operated in a commercial environment. This equipment generates, uses, and can radiate radio frequency energy and, if not installed and used in accordance with the instruction manual, may cause harmful interference to radio communications. Operation of this equipment in a residential area is likely to cause harmful interference in which case the user will be required to correct the interference at his own expense.

(Part 15.21) Any changes or modifications not expressly approved by the party responsible for compliance could void the user's authority to operate this equipment.

Industry Canada Statement for Intentional Radiators

This device contains licence-exempt transmitter(s)/receiver(s) that comply with Innovation, Science and Economic Development Canada's licence-exempt RSS(s). Operation is subject to the following two conditions:

1. This device may not cause interference.
2. This device must accept any interference, including interference that may cause undesired operation of the device.

Cet appareil contient des émetteurs/récepteurs exemptés de licence conformes à la norme Innovation, Sciences, et Développement économique Canada. L'exploitation est autorisée aux deux conditions suivantes:

1. L'appareil ne doit pas produire de brouillage.
2. L'utilisateur de l'appareil doit accepter tout brouillage radioélectrique subi, même si le brouillage est susceptible d'en compromettre le fonctionnement.

Dimensions

All measurements are listed in millimeters [inches], unless noted otherwise. The measurements provided are subject to change.

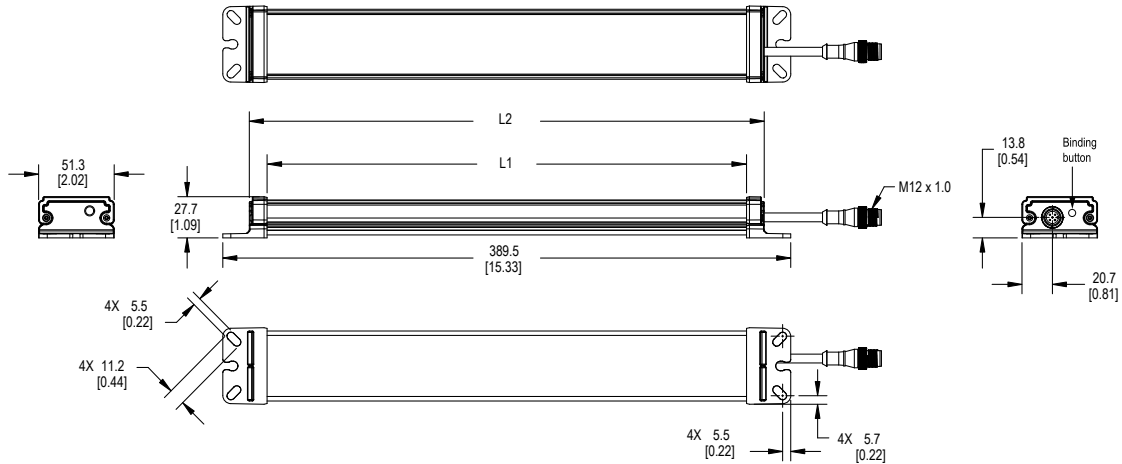

Models	L1	L2
SD50..300..	329.5 mm (12.97 in)	353.5 mm (13.92 in)

Chapter Contents

R70 Buttons and LEDs..... 6
 Bind the SD50 to the R70..... 7

Chapter 2 Configuration Instructions

R70 Buttons and LEDs

Binding button, LEDs, and DIP switches

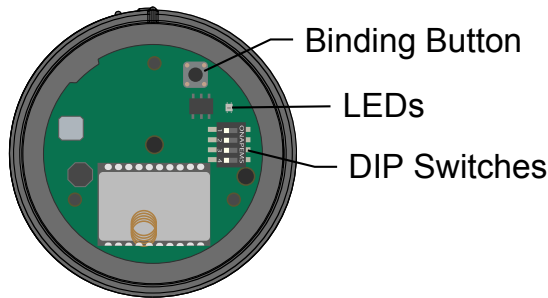

Set the R70SR DIP Switches

To use the SD50 with the R70SR SNAP SIGNAL Serial Data Radio, the R70SR DIP switches must be set to the following positions.

1. On the R70SR, open the cover. (If the cover is in the locked position, the cover arrow is aligned above the notch on the base.)
 - a. Rotate the cover counterclockwise so that the notches are aligned.
 - b. Pull the top cover off.
2. Set the R70SR DIP switches as listed, according to the requirements of your specific installation.

Serial Broadcast Mode Configuration with a Star Network--In this more complex star topology, the client radio at the center of the network can communicate to many server radios. A common example would be a PLC at the center communicating with many remote I/O systems. The star topology is slower than a point-to-point network, but faster than a tree network.

Example SD50 Wireless network layout (star topology)

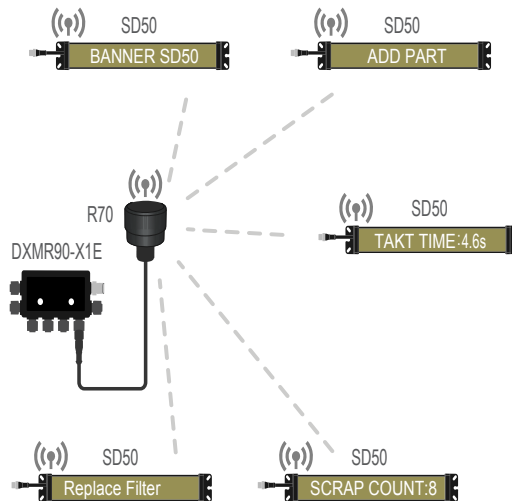

Device Settings	DIP Switches			
	1	2	3	4
Client configuration to broadcast to all devices	OFF	ON	OFF	ON

Bind the SD50 to the R70

Follow these instructions to bind your SD50 Wireless Status Display to the R70 serial data radio.

1. Connect the R70 data radio to the DXM Controller.
2. Verify the R70 data radio DIP switches are set (see ["Set the R70SR DIP Switches" on page 6](#)).
3. Connect the SD50 Wireless Status Display to power.
The SD50 shows the device ID on the display.
4. Verify the R70SR radio at least two meters away from the SD50 radios.
5. On the R70: Remove the cover and press the binding button three times to put it in binding mode.
6. On the SD50: Press the binding button three times.
The SD50 binding button (yellow) is on the bottom of the device, near the cable.
The display shows **Binding Mode**. After the SD50 is bound to the R70, the SD50's display shows **Bound**.
7. Repeat steps 3 through 6 for each SD50 Wireless Status Display you'd like to bind to the R70.
8. Press the R70 binding button twice to exit binding mode.
9. Assign a unique ID to each SD50 Wireless Status Display to ensure you communicate to the correct device.
To set the SD50 Wireless Status Display device ID, write the ID to register 46100 (see [Modbus Configuration](#)) by connecting directly to a Modbus controller. When writing registers to any SD50 Wireless Status Display, you must include this device ID.

Chapter Contents

Holding Register Column Definitions.....	8
Modbus Configuration	8
Device Information	9
Operation Mode.....	9
Display Settings.....	48
Custom Settings	49
Restore Factory Defaults.....	50

Chapter 3 Modbus Register Map

Holding Register Column Definitions

Base 0 Address

Registers are addressed with the first register starting at zero

Base 1 Address

Registers are addressed with the first register starting at one

Description

Lists the functionality of the register

Holding Register Representation

Lists the allowed values of the register and the definition of those values

Default Value

Lists the factory default value of the register

Saved

Yes: The register value is stored in non-volatile memory, and is preserved when power is cycled

No: The register value is stored in volatile memory, and is reset to the default value when power is cycled

Access

Read Only (RO): The register can be read, but not written to

Read and Write (RW): The register can be read and written to

Modbus Configuration

Use these registers to configure Modbus communications.

Base 0 Address	Base 1 Address	Description	Holding Register Representation	Default Value	Saved	Access
46100	46101	Address	1-254	1	Yes	RW
46101	46102	Baud Rate	96 = 9.6k 192 = 19.2k 384 = 38.4k	192	Yes	RW
46102	46103	Parity	0 = None 1 = Odd 2 = Even	0	Yes	RW
46103	46104	Stop Bits	1 = 1 Bit 2 = 2 Bits 3 = 1.5 Bits	1	Yes	RW

Device Information

The following registers list the model name and other device-specific information.

Base 0 Address	Base 1 Address	Description	Holding Register Representation	Default Value	Saved	Access
40605-40615	40606-40616	Banner Name		Banner Engineering	Yes	RO
40616-40631	40617-40632	Product Name		See Device	Yes	RO
40632	40633	Item H	Item Number is split into two 16-bit registers	See Device	Yes	RO
40633	40634	Item L		See Device	Yes	RO
40634	40635	Serial Number 1 (H)		See Device	Yes	RO
40635	40636	Serial Number 2		See Device	Yes	RO
40636	40637	Serial Number 3		See Device	Yes	RO
40637	40638	Serial Number 4 (L)		See Device	Yes	RO
40638	40639	Firmware PN H	230038 is split into two 16-bit registers	See Device	Yes	RO
40639	40640	Firmware PN L		See Device	Yes	RO
40640	40641	Firmware Version H		See Device	Yes	RO
40641	40642	Firmware Version L		See Device	Yes	RO
40642	40643	Firmware Build Number H		See Device	Yes	RO
40643	40644	Firmware Build Number L		See Device	Yes	RO
40644-40659	40645-40660	User-Defined Tag	User writable space	More Sensors. More Solutions.	Yes	RW

Operation Mode

Use this register to select the main operation mode of the device.

Base 0 Address	Base 1 Address	Description	Holding Register Representation	Default Value	Saved	Access
42200	42201	Operation Mode	0 = Run Mode 1 = Message Mode 2 = Level Mode 3 = Timer Mode 4 = Counter Mode	0	Yes	RW

Run Mode

Use one register to activate the defined device state. Use additional non-volatile registers to define color, intensity, animation, and display message.

Base 0 Address	Base 1 Address	Description	Holding Register Representation	Default Value	Saved	Access	Comments
42000	42001	Run Mode Animation	0 = Off 1 = Steady 2 = Flash 3 = Two Color Flash 4 = 50/50 5 = 50/50 Flash 6 = Intensity Sweep 7 = Two Color Sweep	0	No	RW	
42001	42002	Run Mode Color 1	0 = Green 1 = Red 2 = Orange 3 = Amber 4 = Yellow 5 = Lime Green 6 = Spring Green 7 = Cyan 8 = Sky Blue 9 = Blue 10 = Violet 11 = Magenta 12 = Rose 13 = Daylight White 14 = Custom 1 15 = Custom 2	0	No	RW	
42002	42003	Run Mode Color 1 Intensity	0 = High 1 = Medium 2 = Low 3 = Off 4 = Custom	0	No	RW	
42003	42004	Run Mode Speed	0 = Slow 1 = Standard 2 = Fast 3 = Custom	0	No	RW	
42004	42005	Run Mode Pattern	0 = Normal 1 = Strobe 2 = 3-Pulse 3 = SOS 4 = Random	0	No	RW	

Continued on page 10

Continued from page 10

Base 0 Address	Base 1 Address	Description	Holding Register Representation	Default Value	Saved	Access	Comments
42005	42006	Run Mode Color 2	0 = Green 1 = Red 2 = Orange 3 = Amber 4 = Yellow 5 = Lime Green 6 = Spring Green 7 = Cyan 8 = Sky Blue 9 = Blue 10 = Violet 11 = Magenta 12 = Rose 13 = Daylight White 14 = Custom 1 15 = Custom 2	0	No	RW	
42006	42007	Run Mode Color 2 Intensity	0 = High 1 = Medium 2 = Low 3 = Off 4 = Custom	0	No	RW	
42008-42022	42009-42023	Run Mode String	Example: Register 42009: 0x4241 (hex) = BA Register 42010: 0x4E4E (hex) = NN Register 42011: 0x4552 (hex) = ER See "Encoding Table and Unicode Characters" on page 52	0x0000	No	RW	(15 words/30 Characters)

Message Mode

Use one register to activate the defined device state. Use additional non-volatile registers to define color, intensity, animation, and display saved messages.

Base 0 Address	Base 1 Address	Description	Holding Register Representation	Default Value	Saved	Access	Comments
42000	42001	Message Mode Animation	0 = Off 1 = Steady 2 = Flash 3 = Two Color Flash 4 = 50/50 5 = 50/50 Flash 6 = Intensity Sweep 7 = Two Color Sweep	0	No	RW	

Continued on page 12

Continued from page 11

Base 0 Address	Base 1 Address	Description	Holding Register Representation	Default Value	Saved	Access	Comments
42001	42002	Message Mode Color 1	0 = Green 1 = Red 2 = Orange 3 = Amber 4 = Yellow 5 = Lime Green 6 = Spring Green 7 = Cyan 8 = Sky Blue 9 = Blue 10 = Violet 11 = Magenta 12 = Rose 13 = Daylight White 14 = Custom 1 15 = Custom 2	0	No	RW	
42002	42003	Message Mode Color 1 Intensity	0 = High 1 = Medium 2 = Low 3 = Off 4 = Custom	0	No	RW	
42003	42004	Message Mode Speed	0 = Slow 1 = Standard 2 = Fast 3 = Custom	0	No	RW	
42004	42005	Message Mode Pattern	0 = Normal 1 = Strobe 2 = 3-Pulse 3 = SOS 4 = Random	0	No	RW	

Continued on page 13

Continued from page 12

Base 0 Address	Base 1 Address	Description	Holding Register Representation	Default Value	Saved	Access	Comments
42005	42006	Message Mode Color 2	0 = Green 1 = Red 2 = Orange 3 = Amber 4 = Yellow 5 = Lime Green 6 = Spring Green 7 = Cyan 8 = Sky Blue 9 = Blue 10 = Violet 11 = Magenta 12 = Rose 13 = Daylight White 14 = Custom 1 15 = Custom 2	0	No	RW	
42006	42007	Message Mode Color 2 Intensity	0 = High 1 = Medium 2 = Low 3 = Off 4 = Custom	0	No	RW	
42007	42008	Message Mode Message 1	0 = Message 0 (Blank) 1 = Message 1 2 = Message 2 3 = Message 3 4 = Message 4 5 = Message 5 6 = Message 6 7 = Message 7 8 = Message 8 9 = Message 9 10 = Message 10 11 = Message 11 12 = Message 12 13 = Message 13 14 = Message 14	0	No	RW	

Continued on page 14

Continued from page 13

Base 0 Address	Base 1 Address	Description	Holding Register Representation	Default Value	Saved	Access	Comments
42008	42009	Message Mode Message 2	0 = Message 0 (Blank) 1 = Message 1 2 = Message 2 3 = Message 3 4 = Message 4 5 = Message 5 6 = Message 6 7 = Message 7 8 = Message 8 9 = Message 9 10 = Message 10 11 = Message 11 12 = Message 12 13 = Message 13 14 = Message 14	0	No	RW	

Message Mode Messages

Use the following registers to define each of the fifteen available messages.

Base 0 Address	Base 1 Address	Description	Holding Register Representation	Default Value	Saved	Access	Comments
42400-42415	42401-42416	Message 0 (BLANK)			Yes	RW	(16 words/ 32 characters)
42416-42431	42417-42432	Message 1	Reset		Yes	RW	(16 words/ 32 characters)
42432-42447	42432-42448	Message 2	Fault		Yes	RW	(16 words/ 32 characters)
42448-42463	42449-42464	Message 3	Stop		Yes	RW	(16 words/ 32 characters)
42464-42479	42465-42480	Message 4	Start		Yes	RW	(16 words/ 32 characters)
42480-42495	42481-42496	Message 5	Changeover		Yes	RW	(16 words/ 32 characters)
42496-42511	42497-42512	Message 6	Open		Yes	RW	(16 words/ 32 characters)
42512-42527	42513-42528	Message 7	Welcome		Yes	RW	(16 words/ 32 characters)
42528-42543	42529-42544	Message 8	Quality		Yes	RW	(16 words/ 32 characters)
42544-42559	42545-42590	Message 9	Warning		Yes	RW	(16 words/ 32 characters)

Continued on page 15

Continued from page 14

Base 0 Address	Base 1 Address	Description	Holding Register Representation	Default Value	Saved	Access	Comments
42560-42575	42561-42576	Message 10		Alarm	Yes	RW	(16 words/32 characters)
42576-42591	42577-42592	Message 11		Break	Yes	RW	(16 words/32 characters)
42592-42607	42593-42608	Message 12		Run	Yes	RW	(16 words/32 characters)
42608-42623	42609-42624	Message 13		Maintenance	Yes	RW	(16 words/32 characters)
42624-42639	42625-42640	Message 14		Closed	Yes	RW	(16 words/32 characters)
42640-42655	42641-42656	Message 15		Material	Yes	RW	(16 words/32 characters)

Level Mode

Use Level Mode to display a level based on a scaled input value.

Base 0 Address	Base 1 Address	Description	Holding Register Representation	Default Value	Saved	Access
42000	42001	Level Mode Value	0-65535	0	No	RW

Level Mode General Configuration

Use these registers to set the filter, labels, bar graph, and other settings of Level Mode.

Base 0 Address	Base 1 Address	Description	Holding Register Representation	Default Value	Saved	Access	Comments
42700	42701	Filter Level	0 = None 1 = Low 2 = Medium 3 = High	0	Yes	RW	
42701	42702	Hysteresis Level	0 = None 1 = Low 2 = Medium 3 = High	0	Yes	RW	
42702-42709	42703-42710	Level Mode Data Label		Time =	Yes	RW	(8 words/16 characters)
42710	42711	Level Mode Value	0 = Disabled 1 = Enabled	1	Yes	RW	
42711	42712	Level Mode Bar Graph	0 = Disabled 1 = Enabled	1	Yes	RW	
42712	42713	Output Scale Value Low	0-65535	0	Yes	RW	
42713	42714	Output Scale Value High	0-65535	10	Yes	RW	
42714	42715	Input Scale Value Low	0-65535	0	Yes	RW	
42715	42716	Input Scale Value High	0-65535	65535	Yes	RW	

Continued on page 16

Continued from page 15

Base 0 Address	Base 1 Address	Description	Holding Register Representation	Default Value	Saved	Access	Comments
42716-42717	42717-42718	Level Mode Value Label		s	Yes	RW	(2 words/4 characters)
42718	42719	Level Mode Display Orientation	0 = 0 degrees 1 = 180 degrees 2 = 90 degrees 3 = 270 degrees	0	Yes	RW	
42719	42720	Level Mode Minimal Bar Graph	0 = Disabled 1 = Enabled	0	Yes	RW	
42720	42721	Level Mode Decimal Places	0-3	1	Yes	RW	
42721	42722	Level Mode Display As Time	0 = Disabled 1 = Enabled	0	Yes	RW	

Level Mode Base Configuration

Use these registers to set the colors, animations, and audible for Level Mode.

Base 0 Address	Base 1 Address	Description	Holding Register Representation	Default Value	Saved	Access	Comments
42722	42723	Display Override	0 = Disabled 1 = Enabled	0	Yes	RW	
42723-42738	42724-42739	Override String		Base	Yes	RW	(16 words/32 characters)
42739	42740	Animation	0 = Off 1 = Steady 2 = Flash 3 = Two Color Flash 4 = 50/50 5 = 50/50 Flash 6 = Intensity Sweep 7 = Two Color Sweep	0	Yes	RW	

Continued on page 17

Continued from page 16

Base 0 Address	Base 1 Address	Description	Holding Register Representation	Default Value	Saved	Access	Comments
42740	42741	Color 1	0 = Green 1 = Red 2 = Orange 3 = Amber 4 = Yellow 5 = Lime Green 6 = Spring Green 7 = Cyan 8 = Sky Blue 9 = Blue 10 = Violet 11 = Magenta 12 = Rose 13 = Daylight White 14 = Custom 1 15 = Custom 2	0	Yes	RW	
42741	42742	Color 1 Intensity	0 = High 1 = Medium 2 = Low 3 = Off 4 = Custom	0	Yes	RW	
42742	42743	Speed	0 = Slow 1 = Standard 2 = Fast 3 = Custom	1	Yes	RW	
42743	42744	Pattern	0 = Normal 1 = Strobe 2 = 3-Pulse 3 = SOS 4 = Random	0	Yes	RW	

Continued on page 18

Continued from page 17

Base 0 Address	Base 1 Address	Description	Holding Register Representation	Default Value	Saved	Access	Comments
42744	42745	Color 2	0 = Green 1 = Red 2 = Orange 3 = Amber 4 = Yellow 5 = Lime Green 6 = Spring Green 7 = Cyan 8 = Sky Blue 9 = Blue 10 = Violet 11 = Magenta 12 = Rose 13 = Daylight White 14 = Custom 1 15 = Custom 2	0	Yes	RW	
42745	42746	Color 2 Intensity	0 = High 1 = Medium 2 = Low 3 = Off 4 = Custom	0	Yes	RW	

Level Mode Threshold 1 Configuration

Base 0 Address	Base 1 Address	Description	Holding Register Representation	Default Value	Saved	Access	Comments
42748	42749	Is Enabled	0 = Disabled 1 = Enabled	1	Yes	RW	
42749	42750	Percent	0-100	25	Yes	RW	
42750	42751	Type	0 = Less Than or Equal To 1 = Greater Than	0	Yes	RW	
42751	42752	Threshold Override	0 = Disabled 1 = Enabled	0	Yes	RW	
42752	42753	Display Override	0 = Disabled 1 = Enabled	0	Yes	RW	
42753-42768	42754-42769	Override String		Thresh 1	Yes	RW	(16 words/32 characters)

Continued on page 19

Continued from page 18

Base 0 Address	Base 1 Address	Description	Holding Register Representation	Default Value	Saved	Access	Comments
42769	42770	Animation	0 = Off 1 = Steady 2 = Flash 3 = Two Color Flash 4 = 50/50 5 = 50/50 Flash 6 = Intensity Sweep 7 = Two Color Sweep	0	Yes	RW	
42770	42771	Color 1	0 = Green 1 = Red 2 = Orange 3 = Amber 4 = Yellow 5 = Lime Green 6 = Spring Green 7 = Cyan 8 = Sky Blue 9 = Blue 10 = Violet 11 = Magenta 12 = Rose 13 = Daylight White 14 = Custom 1 15 = Custom 2	0	Yes	RW	
42771	42772	Color 1 Intensity	0 = High 1 = Medium 2 = Low 3 = Off 4 = Custom	0	Yes	RW	
42772	42773	Speed	0 = Slow 1 = Standard 2 = Fast 3 = Custom	1	Yes	RW	
42773	42774	Pattern	0 = Normal 1 = Strobe 2 = 3-Pulse 3 = SOS 4 = Random	0	Yes	RW	

Continued on page 20

Continued from page 19

Base 0 Address	Base 1 Address	Description	Holding Register Representation	Default Value	Saved	Access	Comments
42774	42775	Color 2	0 = Green 1 = Red 2 = Orange 3 = Amber 4 = Yellow 5 = Lime Green 6 = Spring Green 7 = Cyan 8 = Sky Blue 9 = Blue 10 = Violet 11 = Magenta 12 = Rose 13 = Daylight White 14 = Custom 1 15 = Custom 2	0	Yes	RW	
42775	42776	Color 2 Intensity	0 = High 1 = Medium 2 = Low 3 = Off 4 = Custom	0	Yes	RW	

Level Mode Threshold 2 Configuration

Base 0 Address	Base 1 Address	Description	Holding Register Representation	Default Value	Saved	Access	Comments
42778	42779	Is Enabled	0 = Disabled 1 = Enabled	1	Yes	RW	
42779	42780	Percent	0-100	25	Yes	RW	
42780	42781	Type	0 = Less Than or Equal To 1 = Greater Than	0	Yes	RW	
42781	42782	Threshold Override	0 = Disabled 1 = Enabled	0	Yes	RW	
42782	42783	Display Override	0 = Disabled 1 = Enabled	0	Yes	RW	
42783-42798	42784-42799	Override String		Thresh 1	Yes	RW	(16 words/32 characters)

Continued on page 21

Continued from page 20

Base 0 Address	Base 1 Address	Description	Holding Register Representation	Default Value	Saved	Access	Comments
42799	42800	Animation	0 = Off 1 = Steady 2 = Flash 3 = Two Color Flash 4 = 50/50 5 = 50/50 Flash 6 = Intensity Sweep 7 = Two Color Sweep	0	Yes	RW	
42800	42801	Color 1	0 = Green 1 = Red 2 = Orange 3 = Amber 4 = Yellow 5 = Lime Green 6 = Spring Green 7 = Cyan 8 = Sky Blue 9 = Blue 10 = Violet 11 = Magenta 12 = Rose 13 = Daylight White 14 = Custom 1 15 = Custom 2	0	Yes	RW	
42801	42802	Color 1 Intensity	0 = High 1 = Medium 2 = Low 3 = Off 4 = Custom	0	Yes	RW	
42802	42803	Speed	0 = Slow 1 = Standard 2 = Fast 3 = Custom	1	Yes	RW	
42803	42804	Pattern	0 = Normal 1 = Strobe 2 = 3-Pulse 3 = SOS 4 = Random	0	Yes	RW	

Continued on page 22

Continued from page 21

Base 0 Address	Base 1 Address	Description	Holding Register Representation	Default Value	Saved	Access	Comments
42804	42805	Color 2	0 = Green 1 = Red 2 = Orange 3 = Amber 4 = Yellow 5 = Lime Green 6 = Spring Green 7 = Cyan 8 = Sky Blue 9 = Blue 10 = Violet 11 = Magenta 12 = Rose 13 = Daylight White 14 = Custom 1 15 = Custom 2	0	Yes	RW	
42805	42806	Color 2 Intensity	0 = High 1 = Medium 2 = Low 3 = Off 4 = Custom	0	Yes	RW	

Level Mode Threshold 3 Configuration

Base 0 Address	Base 1 Address	Description	Holding Register Representation	Default Value	Saved	Access	Comments
42808	42809	Is Enabled	0 = Disabled 1 = Enabled	1	Yes	RW	
42809	42810	Percent	0-100	25	Yes	RW	
42810	42811	Type	0 = Less Than or Equal To 1 = Greater Than	0	Yes	RW	
42811	42812	Threshold Override	0 = Disabled 1 = Enabled	0	Yes	RW	
42812	42813	Display Override	0 = Disabled 1 = Enabled	0	Yes	RW	
42813-42828	42814-42829	Override String		Thresh 1	Yes	RW	(16 words/32 characters)

Continued on page 23

Continued from page 22

Base 0 Address	Base 1 Address	Description	Holding Register Representation	Default Value	Saved	Access	Comments
42829	42830	Animation	0 = Off 1 = Steady 2 = Flash 3 = Two Color Flash 4 = 50/50 5 = 50/50 Flash 6 = Intensity Sweep 7 = Two Color Sweep	0	Yes	RW	
42830	42831	Color 1	0 = Green 1 = Red 2 = Orange 3 = Amber 4 = Yellow 5 = Lime Green 6 = Spring Green 7 = Cyan 8 = Sky Blue 9 = Blue 10 = Violet 11 = Magenta 12 = Rose 13 = Daylight White 14 = Custom 1 15 = Custom 2	0	Yes	RW	
42831	42832	Color 1 Intensity	0 = High 1 = Medium 2 = Low 3 = Off 4 = Custom	0	Yes	RW	
42832	42833	Speed	0 = Slow 1 = Standard 2 = Fast 3 = Custom	1	Yes	RW	
42833	42834	Pattern	0 = Normal 1 = Strobe 2 = 3-Pulse 3 = SOS 4 = Random	0	Yes	RW	

Continued on page 24

Continued from page 23

Base 0 Address	Base 1 Address	Description	Holding Register Representation	Default Value	Saved	Access	Comments
42834	42835	Color 2	0 = Green 1 = Red 2 = Orange 3 = Amber 4 = Yellow 5 = Lime Green 6 = Spring Green 7 = Cyan 8 = Sky Blue 9 = Blue 10 = Violet 11 = Magenta 12 = Rose 13 = Daylight White 14 = Custom 1 15 = Custom 2	0	Yes	RW	
42835	42836	Color 2 Intensity	0 = High 1 = Medium 2 = Low 3 = Off 4 = Custom	0	Yes	RW	

Level Mode Threshold 4 Configuration

Base 0 Address	Base 1 Address	Description	Holding Register Representation	Default Value	Saved	Access	Comments
42838	42839	Is Enabled	0 = Disabled 1 = Enabled	1	Yes	RW	
42839	42840	Percent	0-100	25	Yes	RW	
42840	42841	Type	0 = Less Than or Equal To 1 = Greater Than	0	Yes	RW	
42841	42842	Threshold Override	0 = Disabled 1 = Enabled	0	Yes	RW	
42842	42843	Display Override	0 = Disabled 1 = Enabled	0	Yes	RW	
42843-42858	42844-42859	Override String		Thresh 1	Yes	RW	(16 words/32 characters)

Continued on page 25

Continued from page 24

Base 0 Address	Base 1 Address	Description	Holding Register Representation	Default Value	Saved	Access	Comments
42859	42860	Animation	0 = Off 1 = Steady 2 = Flash 3 = Two Color Flash 4 = 50/50 5 = 50/50 Flash 6 = Intensity Sweep 7 = Two Color Sweep	0	Yes	RW	
42860	42861	Color 1	0 = Green 1 = Red 2 = Orange 3 = Amber 4 = Yellow 5 = Lime Green 6 = Spring Green 7 = Cyan 8 = Sky Blue 9 = Blue 10 = Violet 11 = Magenta 12 = Rose 13 = Daylight White 14 = Custom 1 15 = Custom 2	0	Yes	RW	
42861	42862	Color 1 Intensity	0 = High 1 = Medium 2 = Low 3 = Off 4 = Custom	0	Yes	RW	
42862	42863	Speed	0 = Slow 1 = Standard 2 = Fast 3 = Custom	1	Yes	RW	
42863	42864	Pattern	0 = Normal 1 = Strobe 2 = 3-Pulse 3 = SOS 4 = Random	0	Yes	RW	

Continued on page 26

Continued from page 25

Base 0 Address	Base 1 Address	Description	Holding Register Representation	Default Value	Saved	Access	Comments
42864	42865	Color 2	0 = Green 1 = Red 2 = Orange 3 = Amber 4 = Yellow 5 = Lime Green 6 = Spring Green 7 = Cyan 8 = Sky Blue 9 = Blue 10 = Violet 11 = Magenta 12 = Rose 13 = Daylight White 14 = Custom 1 15 = Custom 2	0	Yes	RW	
42865	42866	Color 2 Intensity	0 = High 1 = Medium 2 = Low 3 = Off 4 = Custom	0	Yes	RW	

Timer Mode

Use these registers to set the inputs and value of Timer Mode.

Base 0 Address	Base 1 Address	Description	Holding Register Representation	Default Value	Saved	Access
42000	42001	Run/Pause Input	0 = Off (Paused) 1 = On (Counting)	0	No	RW
42001	42002	Reset Input	0 = Off 1 = On	0	No	RW
42900	42901	Timer Value	0-65535		Yes	RW

Timer Mode Settings

Use these registers to set the units, direction, and reset of Timer Mode.

Base 0 Address	Base 1 Address	Description	Holding Register Representation	Default Value	Saved	Access
42901	42902	Timer Unit Type	0 = Days 1 = Hours 2 = Minutes 3 = Seconds	0	Yes	RW

Continued on page 27

Continued from page 26

Base 0 Address	Base 1 Address	Description	Holding Register Representation	Default Value	Saved	Access
42902	42903	Timer Count Type	0 = Down 1 = Up	0	Yes	RW
42903	42904	Enable Auto Reset	0 = Disabled 1 = Enabled	0	Yes	RW

Timer Mode General Configuration

Use these registers to set the filter, labels, bar graph, and other settings of Timer Mode.

Base 0 Address	Base 1 Address	Description	Holding Register Representation	Default Value	Saved	Access	Comments
42700	42701	Filter Level	0 = None 1 = Low 2 = Medium 3 = High	0	Yes	RW	
42701	42702	Hysteresis Level	0 = None 1 = Low 2 = Medium 3 = High	0	Yes	RW	
42702-42709	42703-42710	Timer Mode Data Label		Time =	Yes	RW	(8 words/ 16 characters)
42710	42711	Timer Mode Value	0 = Disabled 1 = Enabled	1	Yes	RW	
42711	42712	Timer Mode Bar Graph	0 = Disabled 1 = Enabled	1	Yes	RW	
42712	42713	Output Scale Value Low	0-65535	0	Yes	RW	
42713	42714	Output Scale Value High	0-65535	10	Yes	RW	
42714	42715	Input Scale Value Low	0-65535	0	Yes	RW	
42715	42716	Input Scale Value High	0-65535	65535	Yes	RW	
42716-42717	42717-42718	Timer Mode Value Label		s	Yes	RW	(2 words/ 4 characters)
42718	42719	Timer Mode Display Orientation	0 = 0 degrees 1 = 180 degrees 2 = 90 degrees 3 = 270 degrees	0	Yes	RW	
42719	42720	Timer Mode Minimal Bar Graph	0 = Disabled 1 = Enabled	0	Yes	RW	
42720	42721	Timer Mode Decimal Places	0-3	1	Yes	RW	
42721	42722	Timer Mode Display As Time	0 = Disabled 1 = Enabled	0	Yes	RW	

Timer Mode Base Configuration

Use these registers to set the colors, animations, and audible of Timer Mode.

Base 0 Address	Base 1 Address	Description	Holding Register Representation	Default Value	Saved	Access	Comments
42722	42723	Display Override	0 = Disabled 1 = Enabled	0	Yes	RW	
42723-42738	42724-42739	Override String		Base	Yes	RW	(16 words/32 characters)
42739	42740	Animation	0 = Off 1 = Steady 2 = Flash 3 = Two Color Flash 4 = 50/50 5 = 50/50 Flash 6 = Intensity Sweep 7 = Two Color Sweep	0	Yes	RW	
42740	42741	Color 1	0 = Green 1 = Red 2 = Orange 3 = Amber 4 = Yellow 5 = Lime Green 6 = Spring Green 7 = Cyan 8 = Sky Blue 9 = Blue 10 = Violet 11 = Magenta 12 = Rose 13 = Daylight White 14 = Custom 1 15 = Custom 2	0	Yes	RW	
42741	42742	Color 1 Intensity	0 = High 1 = Medium 2 = Low 3 = Off 4 = Custom	0	Yes	RW	
42742	42743	Speed	0 = Slow 1 = Standard 2 = Fast 3 = Custom	1	Yes	RW	

Continued on page 28

Continued from page 28

Base 0 Address	Base 1 Address	Description	Holding Register Representation	Default Value	Saved	Access	Comments
42743	42744	Pattern	0 = Normal 1 = Strobe 2 = 3-Pulse 3 = SOS 4 = Random	0	Yes	RW	
42744	42745	Color 2	0 = Green 1 = Red 2 = Orange 3 = Amber 4 = Yellow 5 = Lime Green 6 = Spring Green 7 = Cyan 8 = Sky Blue 9 = Blue 10 = Violet 11 = Magenta 12 = Rose 13 = Daylight White 14 = Custom 1 15 = Custom 2	0	Yes	RW	
42745	42746	Color 2 Intensity	0 = High 1 = Medium 2 = Low 3 = Off 4 = Custom	0	Yes	RW	

Timer Mode Threshold 1 Configuration

Base 0 Address	Base 1 Address	Description	Holding Register Representation	Default Value	Saved	Access	Comments
42748	42749	Is Enabled	0 = Disabled 1 = Enabled	1	Yes	RW	
42749	42750	Percent	0-100	25	Yes	RW	
42750	42751	Type	0 = Less Than or Equal To 1 = Greater Than	0	Yes	RW	
42751	42752	Threshold Override	0 = Disabled 1 = Enabled	0	Yes	RW	
42752	42753	Display Override	0 = Disabled 1 = Enabled	0	Yes	RW	
42753-42768	42754-42769	Override String		Thresh 1	Yes	RW	(16 words/32 characters)

Continued on page 30

Continued from page 29

Base 0 Address	Base 1 Address	Description	Holding Register Representation	Default Value	Saved	Access	Comments
42769	42770	Animation	0 = Off 1 = Steady 2 = Flash 3 = Two Color Flash 4 = 50/50 5 = 50/50 Flash 6 = Intensity Sweep 7 = Two Color Sweep	0	Yes	RW	
42770	42771	Color 1	0 = Green 1 = Red 2 = Orange 3 = Amber 4 = Yellow 5 = Lime Green 6 = Spring Green 7 = Cyan 8 = Sky Blue 9 = Blue 10 = Violet 11 = Magenta 12 = Rose 13 = Daylight White 14 = Custom 1 15 = Custom 2	0	Yes	RW	
42771	42772	Color 1 Intensity	0 = High 1 = Medium 2 = Low 3 = Off 4 = Custom	0	Yes	RW	
42772	42773	Speed	0 = Slow 1 = Standard 2 = Fast 3 = Custom	1	Yes	RW	
42773	42774	Pattern	0 = Normal 1 = Strobe 2 = 3-Pulse 3 = SOS 4 = Random	0	Yes	RW	

Continued on page 31

Continued from page 30

Base 0 Address	Base 1 Address	Description	Holding Register Representation	Default Value	Saved	Access	Comments
42774	42775	Color 2	0 = Green 1 = Red 2 = Orange 3 = Amber 4 = Yellow 5 = Lime Green 6 = Spring Green 7 = Cyan 8 = Sky Blue 9 = Blue 10 = Violet 11 = Magenta 12 = Rose 13 = Daylight White 14 = Custom 1 15 = Custom 2	0	Yes	RW	
42775	42776	Color 2 Intensity	0 = High 1 = Medium 2 = Low 3 = Off 4 = Custom	0	Yes	RW	

Timer Mode Threshold 2 Configuration

Base 0 Address	Base 1 Address	Description	Holding Register Representation	Default Value	Saved	Access	Comments
42778	42779	Is Enabled	0 = Disabled 1 = Enabled	1	Yes	RW	
42779	42780	Percent	0-100	25	Yes	RW	
42780	42781	Type	0 = Less Than or Equal To 1 = Greater Than	0	Yes	RW	
42781	42782	Threshold Override	0 = Disabled 1 = Enabled	0	Yes	RW	
42782	42783	Display Override	0 = Disabled 1 = Enabled	0	Yes	RW	
42783-42798	42784-42799	Override String		Thresh 1	Yes	RW	(16 words/32 characters)

Continued on page 32

Continued from page 31

Base 0 Address	Base 1 Address	Description	Holding Register Representation	Default Value	Saved	Access	Comments
42799	42800	Animation	0 = Off 1 = Steady 2 = Flash 3 = Two Color Flash 4 = 50/50 5 = 50/50 Flash 6 = Intensity Sweep 7 = Two Color Sweep	0	Yes	RW	
42800	42801	Color 1	0 = Green 1 = Red 2 = Orange 3 = Amber 4 = Yellow 5 = Lime Green 6 = Spring Green 7 = Cyan 8 = Sky Blue 9 = Blue 10 = Violet 11 = Magenta 12 = Rose 13 = Daylight White 14 = Custom 1 15 = Custom 2	0	Yes	RW	
42801	42802	Color 1 Intensity	0 = High 1 = Medium 2 = Low 3 = Off 4 = Custom	0	Yes	RW	
42802	42803	Speed	0 = Slow 1 = Standard 2 = Fast 3 = Custom	1	Yes	RW	
42803	42804	Pattern	0 = Normal 1 = Strobe 2 = 3-Pulse 3 = SOS 4 = Random	0	Yes	RW	

Continued on page 33

Continued from page 32

Base 0 Address	Base 1 Address	Description	Holding Register Representation	Default Value	Saved	Access	Comments
42804	42805	Color 2	0 = Green 1 = Red 2 = Orange 3 = Amber 4 = Yellow 5 = Lime Green 6 = Spring Green 7 = Cyan 8 = Sky Blue 9 = Blue 10 = Violet 11 = Magenta 12 = Rose 13 = Daylight White 14 = Custom 1 15 = Custom 2	0	Yes	RW	
42805	42806	Color 2 Intensity	0 = High 1 = Medium 2 = Low 3 = Off 4 = Custom	0	Yes	RW	

Timer Mode Threshold 3 Configuration

Base 0 Address	Base 1 Address	Description	Holding Register Representation	Default Value	Saved	Access	Comments
42808	42809	Is Enabled	0 = Disabled 1 = Enabled	1	Yes	RW	
42809	42810	Percent	0-100	25	Yes	RW	
42810	42811	Type	0 = Less Than or Equal To 1 = Greater Than	0	Yes	RW	
42811	42812	Threshold Override	0 = Disabled 1 = Enabled	0	Yes	RW	
42812	42813	Display Override	0 = Disabled 1 = Enabled	0	Yes	RW	
42813-42828	42814-42829	Override String		Thresh 1	Yes	RW	(16 words/32 characters)

Continued on page 34

Continued from page 33

Base 0 Address	Base 1 Address	Description	Holding Register Representation	Default Value	Saved	Access	Comments
42829	42830	Animation	0 = Off 1 = Steady 2 = Flash 3 = Two Color Flash 4 = 50/50 5 = 50/50 Flash 6 = Intensity Sweep 7 = Two Color Sweep	0	Yes	RW	
42830	42831	Color 1	0 = Green 1 = Red 2 = Orange 3 = Amber 4 = Yellow 5 = Lime Green 6 = Spring Green 7 = Cyan 8 = Sky Blue 9 = Blue 10 = Violet 11 = Magenta 12 = Rose 13 = Daylight White 14 = Custom 1 15 = Custom 2	0	Yes	RW	
42831	42832	Color 1 Intensity	0 = High 1 = Medium 2 = Low 3 = Off 4 = Custom	0	Yes	RW	
42832	42833	Speed	0 = Slow 1 = Standard 2 = Fast 3 = Custom	1	Yes	RW	
42833	42834	Pattern	0 = Normal 1 = Strobe 2 = 3-Pulse 3 = SOS 4 = Random	0	Yes	RW	

Continued on page 35

Continued from page 34

Base 0 Address	Base 1 Address	Description	Holding Register Representation	Default Value	Saved	Access	Comments
42834	42835	Color 2	0 = Green 1 = Red 2 = Orange 3 = Amber 4 = Yellow 5 = Lime Green 6 = Spring Green 7 = Cyan 8 = Sky Blue 9 = Blue 10 = Violet 11 = Magenta 12 = Rose 13 = Daylight White 14 = Custom 1 15 = Custom 2	0	Yes	RW	
42835	42836	Color 2 Intensity	0 = High 1 = Medium 2 = Low 3 = Off 4 = Custom	0	Yes	RW	

Timer Mode Threshold 4 Configuration

Base 0 Address	Base 1 Address	Description	Holding Register Representation	Default Value	Saved	Access	Comments
42838	42839	Is Enabled	0 = Disabled 1 = Enabled	1	Yes	RW	
42839	42840	Percent	0-100	25	Yes	RW	
42840	42841	Type	0 = Less Than or Equal To 1 = Greater Than	0	Yes	RW	
42841	42842	Threshold Override	0 = Disabled 1 = Enabled	0	Yes	RW	
42842	42843	Display Override	0 = Disabled 1 = Enabled	0	Yes	RW	
42843-42858	42844-42859	Override String		Thresh 1	Yes	RW	(16 words/32 characters)

Continued on page 36

Continued from page 35

Base 0 Address	Base 1 Address	Description	Holding Register Representation	Default Value	Saved	Access	Comments
42859	42860	Animation	0 = Off 1 = Steady 2 = Flash 3 = Two Color Flash 4 = 50/50 5 = 50/50 Flash 6 = Intensity Sweep 7 = Two Color Sweep	0	Yes	RW	
42860	42861	Color 1	0 = Green 1 = Red 2 = Orange 3 = Amber 4 = Yellow 5 = Lime Green 6 = Spring Green 7 = Cyan 8 = Sky Blue 9 = Blue 10 = Violet 11 = Magenta 12 = Rose 13 = Daylight White 14 = Custom 1 15 = Custom 2	0	Yes	RW	
42861	42862	Color 1 Intensity	0 = High 1 = Medium 2 = Low 3 = Off 4 = Custom	0	Yes	RW	
42862	42863	Speed	0 = Slow 1 = Standard 2 = Fast 3 = Custom	1	Yes	RW	
42863	42864	Pattern	0 = Normal 1 = Strobe 2 = 3-Pulse 3 = SOS 4 = Random	0	Yes	RW	

Continued on page 37

Continued from page 36

Base 0 Address	Base 1 Address	Description	Holding Register Representation	Default Value	Saved	Access	Comments
42864	42865	Color 2	0 = Green 1 = Red 2 = Orange 3 = Amber 4 = Yellow 5 = Lime Green 6 = Spring Green 7 = Cyan 8 = Sky Blue 9 = Blue 10 = Violet 11 = Magenta 12 = Rose 13 = Daylight White 14 = Custom 1 15 = Custom 2	0	Yes	RW	
42865	42866	Color 2 Intensity	0 = High 1 = Medium 2 = Low 3 = Off 4 = Custom	0	Yes	RW	

Counter Mode

Use Counter Mode to count up or down from a value based on an input signal.

Base 0 Address	Base 1 Address	Description	Holding Register Representation	Default Value	Saved	Access	Comments
42000	42001	Count Increment Input	0 = Off, 1 = Count Up (Pulse)	0	No	RW	Must be pulsed
42001	42002	Count Decrement Input	0 = Off, 1 = Count Down (Pulse)	0	No	RW	Must be pulsed
42002	42003	Reset Input	0 = Off, 1 = Reset Count	0	No	RW	
43000	43001	Count Value			No	RO	Combined into a 32-bit floating-point value output
43001	43002	Count Value			No	RO	

Counter Mode General Configuration

Use these registers to set the labels, filtering, bar graph, and other settings of Counter Mode.

Base 0 Address	Base 1 Address	Description	Holding Register Representation	Default Value	Saved	Access	Comments
42700	42701	Filter Level	0 = None 1 = Low 2 = Medium 3 = High	0	Yes	RW	
42701	42702	Hysteresis Level	0 = None 1 = Low 2 = Medium 3 = High	0	Yes	RW	
42702-42709	42703-42710	Counter Mode Data Label		Time =	Yes	RW	(8 words/ 16 characters)
42710	42711	Counter Mode Value	0 = Disabled 1 = Enabled	1	Yes	RW	
42711	42712	Counter Mode Bar Graph	0 = Disabled 1 = Enabled	1	Yes	RW	
42712	42713	Output Scale Value Low	0-65535	0	Yes	RW	
42713	42714	Output Scale Value High	0-65535	10	Yes	RW	
42714	42715	Input Scale Value Low	0-65535	0	Yes	RW	
42715	42716	Input Scale Value High	0-65535	65535	Yes	RW	
42716-42717	42717-42718	Counter Mode Value Label		s	Yes	RW	(2 words/ 4 characters)
42718	42719	Counter Mode Display Orientation	0 = 0 degrees 1 = 180 degrees 2 = 90 degrees 3 = 270 degrees	0	Yes	RW	
42719	42720	Counter Mode Minimal Bar Graph	0 = Disabled 1 = Enabled	0	Yes	RW	
42720	42721	Counter Mode Decimal Places	0-3	1	Yes	RW	
42721	42722	Counter Mode Display As Time	0 = Disabled 1 = Enabled	0	Yes	RW	

Counter Mode Base Configuration

Base 0 Address	Base 1 Address	Description	Holding Register Representation	Default Value	Saved	Access	Comments
42722	42723	Display Override	0 = Disabled 1 = Enabled	0	Yes	RW	
42723-42738	42724-42739	Override String		Base	Yes	RW	(16 words/32 characters)

Continued on page 39

Continued from page 38

Base 0 Address	Base 1 Address	Description	Holding Register Representation	Default Value	Saved	Access	Comments
42739	42740	Animation	0 = Off 1 = Steady 2 = Flash 3 = Two Color Flash 4 = 50/50 5 = 50/50 Flash 6 = Intensity Sweep 7 = Two Color Sweep	0	Yes	RW	
42740	42741	Color 1	0 = Green 1 = Red 2 = Orange 3 = Amber 4 = Yellow 5 = Lime Green 6 = Spring Green 7 = Cyan 8 = Sky Blue 9 = Blue 10 = Violet 11 = Magenta 12 = Rose 13 = Daylight White 14 = Custom 1 15 = Custom 2	0	Yes	RW	
42741	42742	Color 1 Intensity	0 = High 1 = Medium 2 = Low 3 = Off 4 = Custom	0	Yes	RW	
42742	42743	Speed	0 = Slow 1 = Standard 2 = Fast 3 = Custom	1	Yes	RW	
42743	42744	Pattern	0 = Normal 1 = Strobe 2 = 3-Pulse 3 = SOS 4 = Random	0	Yes	RW	

Continued on page 40

Continued from page 39

Base 0 Address	Base 1 Address	Description	Holding Register Representation	Default Value	Saved	Access	Comments
42744	42745	Color 2	0 = Green 1 = Red 2 = Orange 3 = Amber 4 = Yellow 5 = Lime Green 6 = Spring Green 7 = Cyan 8 = Sky Blue 9 = Blue 10 = Violet 11 = Magenta 12 = Rose 13 = Daylight White 14 = Custom 1 15 = Custom 2	0	Yes	RW	
42745	42746	Color 2 Intensity	0 = High 1 = Medium 2 = Low 3 = Off 4 = Custom	0	Yes	RW	

Counter Mode Threshold 1 Configuration

Base 0 Address	Base 1 Address	Description	Holding Register Representation	Default Value	Saved	Access	Comments
42748	42749	Is Enabled	0 = Disabled 1 = Enabled	1	Yes	RW	
42749	42750	Percent	0-100	25	Yes	RW	
42750	42751	Type	0 = Less Than or Equal To 1 = Greater Than	0	Yes	RW	
42751	42752	Threshold Override	0 = Disabled 1 = Enabled	0	Yes	RW	
42752	42753	Display Override	0 = Disabled 1 = Enabled	0	Yes	RW	
42753-42768	42754-42769	Override String		Thresh 1	Yes	RW	(16 words/32 characters)

Continued on page 41

Continued from page 40

Base 0 Address	Base 1 Address	Description	Holding Register Representation	Default Value	Saved	Access	Comments
42769	42770	Animation	0 = Off 1 = Steady 2 = Flash 3 = Two Color Flash 4 = 50/50 5 = 50/50 Flash 6 = Intensity Sweep 7 = Two Color Sweep	0	Yes	RW	
42770	42771	Color 1	0 = Green 1 = Red 2 = Orange 3 = Amber 4 = Yellow 5 = Lime Green 6 = Spring Green 7 = Cyan 8 = Sky Blue 9 = Blue 10 = Violet 11 = Magenta 12 = Rose 13 = Daylight White 14 = Custom 1 15 = Custom 2	0	Yes	RW	
42771	42772	Color 1 Intensity	0 = High 1 = Medium 2 = Low 3 = Off 4 = Custom	0	Yes	RW	
42772	42773	Speed	0 = Slow 1 = Standard 2 = Fast 3 = Custom	1	Yes	RW	
42773	42774	Pattern	0 = Normal 1 = Strobe 2 = 3-Pulse 3 = SOS 4 = Random	0	Yes	RW	

Continued on page 42

Continued from page 41

Base 0 Address	Base 1 Address	Description	Holding Register Representation	Default Value	Saved	Access	Comments
42774	42775	Color 2	0 = Green 1 = Red 2 = Orange 3 = Amber 4 = Yellow 5 = Lime Green 6 = Spring Green 7 = Cyan 8 = Sky Blue 9 = Blue 10 = Violet 11 = Magenta 12 = Rose 13 = Daylight White 14 = Custom 1 15 = Custom 2	0	Yes	RW	
42775	42776	Color 2 Intensity	0 = High 1 = Medium 2 = Low 3 = Off 4 = Custom	0	Yes	RW	

Counter Mode Threshold 2 Configuration

Base 0 Address	Base 1 Address	Description	Holding Register Representation	Default Value	Saved	Access	Comments
42778	42779	Is Enabled	0 = Disabled 1 = Enabled	1	Yes	RW	
42779	42780	Percent	0-100	25	Yes	RW	
42780	42781	Type	0 = Less Than or Equal To 1 = Greater Than	0	Yes	RW	
42781	42782	Threshold Override	0 = Disabled 1 = Enabled	0	Yes	RW	
42782	42783	Display Override	0 = Disabled 1 = Enabled	0	Yes	RW	
42783-42798	42784-42799	Override String		Thresh 1	Yes	RW	(16 words/32 characters)

Continued on page 43

Continued from page 42

Base 0 Address	Base 1 Address	Description	Holding Register Representation	Default Value	Saved	Access	Comments
42799	42800	Animation	0 = Off 1 = Steady 2 = Flash 3 = Two Color Flash 4 = 50/50 5 = 50/50 Flash 6 = Intensity Sweep 7 = Two Color Sweep	0	Yes	RW	
42800	42801	Color 1	0 = Green 1 = Red 2 = Orange 3 = Amber 4 = Yellow 5 = Lime Green 6 = Spring Green 7 = Cyan 8 = Sky Blue 9 = Blue 10 = Violet 11 = Magenta 12 = Rose 13 = Daylight White 14 = Custom 1 15 = Custom 2	0	Yes	RW	
42801	42802	Color 1 Intensity	0 = High 1 = Medium 2 = Low 3 = Off 4 = Custom	0	Yes	RW	
42802	42803	Speed	0 = Slow 1 = Standard 2 = Fast 3 = Custom	1	Yes	RW	
42803	42804	Pattern	0 = Normal 1 = Strobe 2 = 3-Pulse 3 = SOS 4 = Random	0	Yes	RW	

Continued on page 44

Continued from page 43

Base 0 Address	Base 1 Address	Description	Holding Register Representation	Default Value	Saved	Access	Comments
42804	42805	Color 2	0 = Green 1 = Red 2 = Orange 3 = Amber 4 = Yellow 5 = Lime Green 6 = Spring Green 7 = Cyan 8 = Sky Blue 9 = Blue 10 = Violet 11 = Magenta 12 = Rose 13 = Daylight White 14 = Custom 1 15 = Custom 2	0	Yes	RW	
42805	42806	Color 2 Intensity	0 = High 1 = Medium 2 = Low 3 = Off 4 = Custom	0	Yes	RW	

Counter Mode Threshold 3 Configuration

Base 0 Address	Base 1 Address	Description	Holding Register Representation	Default Value	Saved	Access	Comments
42808	42809	Is Enabled	0 = Disabled 1 = Enabled	1	Yes	RW	
42809	42810	Percent	0-100	25	Yes	RW	
42810	42811	Type	0 = Less Than or Equal To 1 = Greater Than	0	Yes	RW	
42811	42812	Threshold Override	0 = Disabled 1 = Enabled	0	Yes	RW	
42812	42813	Display Override	0 = Disabled 1 = Enabled	0	Yes	RW	
42813-42828	42814-42829	Override String		Thresh 1	Yes	RW	(16 words/32 characters)

Continued on page 45

Continued from page 44

Base 0 Address	Base 1 Address	Description	Holding Register Representation	Default Value	Saved	Access	Comments
42829	42830	Animation	0 = Off 1 = Steady 2 = Flash 3 = Two Color Flash 4 = 50/50 5 = 50/50 Flash 6 = Intensity Sweep 7 = Two Color Sweep	0	Yes	RW	
42830	42831	Color 1	0 = Green 1 = Red 2 = Orange 3 = Amber 4 = Yellow 5 = Lime Green 6 = Spring Green 7 = Cyan 8 = Sky Blue 9 = Blue 10 = Violet 11 = Magenta 12 = Rose 13 = Daylight White 14 = Custom 1 15 = Custom 2	0	Yes	RW	
42831	42832	Color 1 Intensity	0 = High 1 = Medium 2 = Low 3 = Off 4 = Custom	0	Yes	RW	
42832	42833	Speed	0 = Slow 1 = Standard 2 = Fast 3 = Custom	1	Yes	RW	
42833	42834	Pattern	0 = Normal 1 = Strobe 2 = 3-Pulse 3 = SOS 4 = Random	0	Yes	RW	

Continued on page 46

Continued from page 45

Base 0 Address	Base 1 Address	Description	Holding Register Representation	Default Value	Saved	Access	Comments
42834	42835	Color 2	0 = Green 1 = Red 2 = Orange 3 = Amber 4 = Yellow 5 = Lime Green 6 = Spring Green 7 = Cyan 8 = Sky Blue 9 = Blue 10 = Violet 11 = Magenta 12 = Rose 13 = Daylight White 14 = Custom 1 15 = Custom 2	0	Yes	RW	
42835	42836	Color 2 Intensity	0 = High 1 = Medium 2 = Low 3 = Off 4 = Custom	0	Yes	RW	

Counter Mode Threshold 4 Configuration

Base 0 Address	Base 1 Address	Description	Holding Register Representation	Default Value	Saved	Access	Comments
42838	42839	Is Enabled	0 = Disabled 1 = Enabled	1	Yes	RW	
42839	42840	Percent	0-100	25	Yes	RW	
42840	42841	Type	0 = Less Than or Equal To 1 = Greater Than	0	Yes	RW	
42841	42842	Threshold Override	0 = Disabled 1 = Enabled	0	Yes	RW	
42842	42843	Display Override	0 = Disabled 1 = Enabled	0	Yes	RW	
42843-42858	42844-42859	Override String		Thresh 1	Yes	RW	(16 words/32 characters)

Continued on page 47

Continued from page 46

Base 0 Address	Base 1 Address	Description	Holding Register Representation	Default Value	Saved	Access	Comments
42859	42860	Animation	0 = Off 1 = Steady 2 = Flash 3 = Two Color Flash 4 = 50/50 5 = 50/50 Flash 6 = Intensity Sweep 7 = Two Color Sweep	0	Yes	RW	
42860	42861	Color 1	0 = Green 1 = Red 2 = Orange 3 = Amber 4 = Yellow 5 = Lime Green 6 = Spring Green 7 = Cyan 8 = Sky Blue 9 = Blue 10 = Violet 11 = Magenta 12 = Rose 13 = Daylight White 14 = Custom 1 15 = Custom 2	0	Yes	RW	
42861	42862	Color 1 Intensity	0 = High 1 = Medium 2 = Low 3 = Off 4 = Custom	0	Yes	RW	
42862	42863	Speed	0 = Slow 1 = Standard 2 = Fast 3 = Custom	1	Yes	RW	
42863	42864	Pattern	0 = Normal 1 = Strobe 2 = 3-Pulse 3 = SOS 4 = Random	0	Yes	RW	

Continued on page 48

Continued from page 47

Base 0 Address	Base 1 Address	Description	Holding Register Representation	Default Value	Saved	Access	Comments
42864	42865	Color 2	0 = Green 1 = Red 2 = Orange 3 = Amber 4 = Yellow 5 = Lime Green 6 = Spring Green 7 = Cyan 8 = Sky Blue 9 = Blue 10 = Violet 11 = Magenta 12 = Rose 13 = Daylight White 14 = Custom 1 15 = Custom 2	0	Yes	RW	
42865	42866	Color 2 Intensity	0 = High 1 = Medium 2 = Low 3 = Off 4 = Custom	0	Yes	RW	

Display Settings

Use these registers to set the general Display Settings for the device.

Base 0 Address	Base 1 Address	Description	Holding Register Representation	Default Value	Saved	Access
42300	42301	Text Color	0 = White 1 = Black	0	Yes	RW
42301	42302	Intensity	0 = High 1 = Medium 2 = Low 3 = Off 4 = Custom	0	Yes	RW
42302	42303	Scroll Direction	0 = Away From Connector 1 = Towards Connector	0	Yes	RW
42303	42304	Scroll Speed	0 = Slow 1 = Standard 2 = Fast 3 = Custom	1	Yes	RW

Continued on page 49

Continued from page 48

Base 0 Address	Base 1 Address	Description	Holding Register Representation	Default Value	Saved	Access
42304	42305	Mirrored Text	0 = Disable 1 = Enabled			
42305	42306	Scroll Mode	0 = Auto 1 = On 2 = Off			
42306	42307	Orientation	0 = 0 Degrees 1 = 180 Degrees 2 = 90 Degrees 3 = 270 Degrees			
42307	42308	Justification	0 = Left 1 = Right 2 = Center	0	Yes	RW

Custom Settings

Base 0 Address	Base 1 Address	Description	Holding Register Representation	Default Value	Saved	Access
42904	42905	Custom Intensity	0-100	100	RW	Yes
42905	42906	Custom Flash Rate (dHz)	1-255	10	RW	Yes
42906	42907	Custom Display Intensity	0-100	100	RW	Yes
42907	42908	Custom Display Scroll Speed	0-255	15	RW	Yes

Custom Color 1 Configuration

Base 0 Address	Base 1 Address	Description	Holding Register Representation	Default Value	Saved	Access
42908	42909	Custom Color 1 Red	0-255	255	RW	Yes
42909	42910	Custom Color 1 Green	0-255	255	RW	Yes
42910	42911	Custom Color 1 Blue	0-255	255	RW	Yes

Custom Color 2 Configuration

Base 0 Address	Base 1 Address	Description	Holding Register Representation	Default Value	Saved	Access
42911	42912	Custom Color 2 Red	0-255	255	RW	Yes
42912	42913	Custom Color 2 Green	0-255	255	RW	Yes
42913	42914	Custom Color 2 Blue	0-255	255	RW	Yes

Restore Factory Defaults

Modbus Register Address	Address with Offset	Description	I/O Range	Comments	Default	Access	Saved	Notes
46600	46601	Factory Reset	0 = Disabled 1 = Enabled	0 = Disabled 1 = Enabled	0	RW	Yes	Restores configuration to factory settings when 1 is written

Chapter Contents

Accessories 51
 Encoding Table and Unicode Characters 52
 Clean with Mild Detergent and Warm Water 57
 Repairs 57
 Contact Us 57
 Banner Engineering Corp Limited Warranty 57

Chapter 4 Product Support and Maintenance

Accessories

Controllers and Radios



DXM Client Models

Models	Description	Technical Documentation
DXM1200-X2	DXM1200-X2 Wireless Controller without a DX80 ISM radio	Datasheet: 238978 Product Manual: 239172
DXM1200-X2R1	DXM1200-X2 Wireless Controller with DX80 ISM 900 MHz radio	
DXM1200-X2R2	DXM1200-X2 Wireless Controller with DX80 ISM 900 MHz MultiHop radio	
DXM1200-X2R3	DXM1200-X2 Wireless Controller with DX80 ISM 2.4 GHz radio	
DXM1200-X2R4	DXM1200-X2 Wireless Controller with DX80 ISM 2.4 GHz MultiHop radio	
DXMR90-X1E	DXMR90-X1E Series Industrial Controller	Datasheet: 242713 Product Manual: 242714

R70SR SNAP SIGNAL Serial Data Radio Server Models

Models	Frequency	Transmit Power	Technical Documentation
R70SR9MQ	900 MHz ISM Band	1 Watt	Datasheet: 233275
R70SR2MQ	2.4 GHz ISM Band	65 mW (100 mW EIRP)	

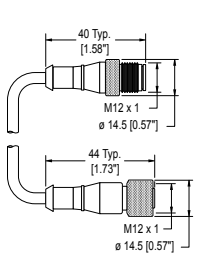
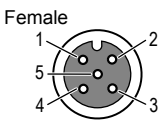
Cordsets

4-pin A-Code Double-Ended M12 Female to M12 Male Cordsets (datasheet p/n 236186)				
Model	Length	Dimensions (mm)	Pinouts	
BC-M12F4-M12M4-22-1	1 m (3.28 ft)		Female 	1 = Brown 2 = White 3 = Blue 4 = Black 5 = Unused 
BC-M12F4-M12M4-22-2	2 m (6.56 ft)			
BC-M12F4-M12M4-22-3	3 m (9.84 ft)			
BC-M12F4-M12M4-22-4	4 m (13.12 ft)			
BC-M12F4-M12M4-22-5	5 m (16.4 ft)			
BC-M12F4-M12M4-22-10	10 m (30.81 ft)			
BC-M12F4-M12M4-22-15	15 m (49.2 ft)			

Mounting Brackets

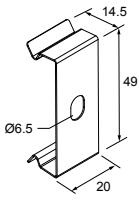
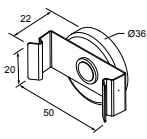
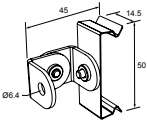
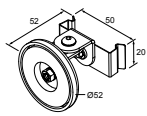
<p>LMBSD50</p> <ul style="list-style-type: none"> • Metal mounting bracket kit • Hardware included • CAD Files: DXF, PDF, IGS, STP 	
<p>LMBSD50MAG</p> <ul style="list-style-type: none"> • Magnetic mounting bracket kit • Up to 7.26 kg (16 lb) pull • Hardware included • CAD Files: DXF, PDF, IGS, STP 	
<p>LMBSD50-180S</p> <ul style="list-style-type: none"> • Metal mounting bracket kit with 180-degree rotation • Stainless steel • Hardware included • CAD Files: DXF, PDF, IGS, STP 	
<p>LMBSD50-180SMAG</p> <ul style="list-style-type: none"> • Magnetic mounting bracket kit with 180-degree rotation • Stainless steel • Up to 7.26 kg (16 lb) pull • Hardware included • CAD Files: DXF, PDF, IGS, STP 	

Encoding Table and Unicode Characters

Unicode Code Point	Character	Name
U+0020		SPACE
U+0021	!	EXCLAMATION MARK
U+0022	"	QUOTATION MARK
U+0023	#	NUMBER SIGN
U+0024	\$	DOLLAR SIGN
U+0025	%	PERCENT SIGN
U+0026	&	AMPERSAND
U+0027	'	APOSTROPHE
U+0028	(LEFT PARENTHESIS
U+0029)	RIGHT PARENTHESIS
U+002A	*	ASTERISK
U+002B	+	PLUS SIGN
U+002C	,	COMMA
U+002D	-	HYPHEN-MINUS
U+002E	.	FULL STOP

Continued on page 53

Continued from page 52

Unicode Code Point	Character	Name
U+002F	/	SOLIDUS
U+0030	0	DIGIT ZERO
U+0031	1	DIGIT ONE
U+0032	2	DIGIT TWO
U+0033	3	DIGIT THREE
U+0034	4	DIGIT FOUR
U+0035	5	DIGIT FIVE
U+0036	6	DIGIT SIX
U+0037	7	DIGIT SEVEN
U+0038	8	DIGIT EIGHT
U+0039	9	DIGIT NINE
U+003A	:	COLON
U+003B	;	SEMICOLON
U+003C	<	LESS-THAN SIGN
U+003D	=	EQUALS SIGN
U+003E	>	GREATER-THAN SIGN
U+003F	?	QUESTION MARK
U+0040	@	COMMERCIAL AT
U+0041	A	LATIN CAPITAL LETTER A
U+0042	B	LATIN CAPITAL LETTER B
U+0043	C	LATIN CAPITAL LETTER C
U+0044	D	LATIN CAPITAL LETTER D
U+0045	E	LATIN CAPITAL LETTER E
U+0046	F	LATIN CAPITAL LETTER F
U+0047	G	LATIN CAPITAL LETTER G
U+0048	H	LATIN CAPITAL LETTER H
U+0049	I	LATIN CAPITAL LETTER I
U+004A	J	LATIN CAPITAL LETTER J
U+004B	K	LATIN CAPITAL LETTER K
U+004C	L	LATIN CAPITAL LETTER L
U+004D	M	LATIN CAPITAL LETTER M
U+004E	N	LATIN CAPITAL LETTER N
U+004F	O	LATIN CAPITAL LETTER O
U+0050	P	LATIN CAPITAL LETTER P
U+0051	Q	LATIN CAPITAL LETTER Q
U+0052	R	LATIN CAPITAL LETTER R
U+0053	S	LATIN CAPITAL LETTER S
U+0054	T	LATIN CAPITAL LETTER T
U+0055	U	LATIN CAPITAL LETTER U
U+0056	V	LATIN CAPITAL LETTER V
U+0057	W	LATIN CAPITAL LETTER W
U+0058	X	LATIN CAPITAL LETTER X

Continued on page 54

Continued from page 53

Unicode Code Point	Character	Name
U+0059	Y	LATIN CAPITAL LETTER Y
U+005A	Z	LATIN CAPITAL LETTER Z
U+005B	[LEFT SQUARE BRACKET
U+005C	\	REVERSE SOLIDUS
U+005D]	RIGHT SQUARE BRACKET
U+005E	^	CIRCUMFLEX ACCENT
U+005F	_	LOW LINE
U+0060	`	GRAVE ACCENT
U+0061	a	LATIN SMALL LETTER A
U+0062	b	LATIN SMALL LETTER B
U+0063	c	LATIN SMALL LETTER C
U+0064	d	LATIN SMALL LETTER D
U+0065	e	LATIN SMALL LETTER E
U+0066	f	LATIN SMALL LETTER F
U+0067	g	LATIN SMALL LETTER G
U+0068	h	LATIN SMALL LETTER H
U+0069	i	LATIN SMALL LETTER I
U+006A	j	LATIN SMALL LETTER J
U+006B	k	LATIN SMALL LETTER K
U+006C	l	LATIN SMALL LETTER L
U+006D	m	LATIN SMALL LETTER M
U+006E	n	LATIN SMALL LETTER N
U+006F	o	LATIN SMALL LETTER O
U+0070	p	LATIN SMALL LETTER P
U+0071	q	LATIN SMALL LETTER Q
U+0072	r	LATIN SMALL LETTER R
U+0073	s	LATIN SMALL LETTER S
U+0074	t	LATIN SMALL LETTER T
U+0075	u	LATIN SMALL LETTER U
U+0076	v	LATIN SMALL LETTER V
U+0077	w	LATIN SMALL LETTER W
U+0078	x	LATIN SMALL LETTER X
U+0079	y	LATIN SMALL LETTER Y
U+007A	z	LATIN SMALL LETTER Z
U+007B	{	LEFT CURLY BRACKET
U+007C		VERTICAL LINE
U+007D	}	RIGHT CURLY BRACKET
U+007E	~	TILDE
U+00A0		NO-BREAK SPACE
U+00A1	¡	INVERTED EXCLAMATION MARK
U+00A2	¢	CENT SIGN
U+00A3	£	POUND SIGN

Continued on page 55

Continued from page 54

Unicode Code Point	Character	Name
U+00A4	¤	CURRENCY SIGN
U+00A5	¥	YEN SIGN
U+00A6	¦	BROKEN BAR
U+00A7	§	SECTION SIGN
U+00A8	¨	DIAERESIS
U+00A9	©	COPYRIGHT SIGN
U+00AA	ª	FEMININE ORDINAL INDICATOR
U+00AB	«	LEFT-POINTING DOUBLE ANGLE QUOTATION MARK
U+00AC	¬	NOT SIGN
U+00AD		SOFT HYPHEN
U+00AE	®	REGISTERED SIGN
U+00AF	—	MACRON
U+00B0	°	DEGREE SIGN
U+00B1	±	PLUS-MINUS SIGN
U+00B2	²	SUPERSCRIPIT TWO
U+00B3	³	SUPERSCRIPIT THREE
U+00B4	´	ACUTE ACCENT
U+00B5	µ	MICRO SIGN
U+00B6	¶	PILCROW SIGN
U+00B7	·	MIDDLE DOT
U+00B8	¸	CEDILLA
U+00B9	¹	SUPERSCRIPIT ONE
U+00BA	º	MASCULINE ORDINAL INDICATOR
U+00BB	»	RIGHT-POINTING DOUBLE ANGLE QUOTATION MARK
U+00BC	¼	VULGAR FRACTION ONE QUARTER
U+00BD	½	VULGAR FRACTION ONE HALF
U+00BE	¾	VULGAR FRACTION THREE QUARTERS
U+00BF	¿	INVERTED QUESTION MARK
U+00C0	À	LATIN CAPITAL LETTER A WITH GRAVE
U+00C1	Á	LATIN CAPITAL LETTER A WITH ACUTE
U+00C2	Â	LATIN CAPITAL LETTER A WITH CIRCUMFLEX
U+00C3	Ã	LATIN CAPITAL LETTER A WITH TILDE
U+00C4	Ä	LATIN CAPITAL LETTER A WITH DIAERESIS
U+00C5	Å	LATIN CAPITAL LETTER A WITH RING ABOVE
U+00C6	Æ	LATIN CAPITAL LETTER AE
U+00C7	Ç	LATIN CAPITAL LETTER C WITH CEDILLA
U+00C8	È	LATIN CAPITAL LETTER E WITH GRAVE
U+00C9	É	LATIN CAPITAL LETTER E WITH ACUTE
U+00CA	Ê	LATIN CAPITAL LETTER E WITH CIRCUMFLEX
U+00CB	Ë	LATIN CAPITAL LETTER E WITH DIAERESIS
U+00CC	Ì	LATIN CAPITAL LETTER I WITH GRAVE
U+00CD	Í	LATIN CAPITAL LETTER I WITH ACUTE

Continued on page 56

Continued from page 55

Unicode Code Point	Character	Name
U+00CE	Î	LATIN CAPITAL LETTER I WITH CIRCUMFLEX
U+00CF	Ï	LATIN CAPITAL LETTER I WITH DIAERESIS
U+00D0	Ð	LATIN CAPITAL LETTER ETH
U+00D1	Ñ	LATIN CAPITAL LETTER N WITH TILDE
U+00D2	Ò	LATIN CAPITAL LETTER O WITH GRAVE
U+00D3	Ó	LATIN CAPITAL LETTER O WITH ACUTE
U+00D4	Ô	LATIN CAPITAL LETTER O WITH CIRCUMFLEX
U+00D5	Õ	LATIN CAPITAL LETTER O WITH TILDE
U+00D6	Ö	LATIN CAPITAL LETTER O WITH DIAERESIS
U+00D7	×	MULTIPLICATION SIGN
U+00D8	Ø	LATIN CAPITAL LETTER O WITH STROKE
U+00D9	Ù	LATIN CAPITAL LETTER U WITH GRAVE
U+00DA	Ú	LATIN CAPITAL LETTER U WITH ACUTE
U+00DB	Û	LATIN CAPITAL LETTER U WITH CIRCUMFLEX
U+00DC	Ü	LATIN CAPITAL LETTER U WITH DIAERESIS
U+00DD	Ý	LATIN CAPITAL LETTER Y WITH ACUTE
U+00DE	Þ	LATIN CAPITAL LETTER THORN
U+00DF	ß	LATIN SMALL LETTER SHARP S
U+00E0	à	LATIN SMALL LETTER A WITH GRAVE
U+00E1	á	LATIN SMALL LETTER A WITH ACUTE
U+00E2	â	LATIN SMALL LETTER A WITH CIRCUMFLEX
U+00E3	ã	LATIN SMALL LETTER A WITH TILDE
U+00E4	ä	LATIN SMALL LETTER A WITH DIAERESIS
U+00E5	å	LATIN SMALL LETTER A WITH RING ABOVE
U+00E6	æ	LATIN SMALL LETTER AE
U+00E7	ç	LATIN SMALL LETTER C WITH CEDILLA
U+00E8	è	LATIN SMALL LETTER E WITH GRAVE
U+00E9	é	LATIN SMALL LETTER E WITH ACUTE
U+00EA	ê	LATIN SMALL LETTER E WITH CIRCUMFLEX
U+00EB	ë	LATIN SMALL LETTER E WITH DIAERESIS
U+00EC	ì	LATIN SMALL LETTER I WITH GRAVE
U+00ED	í	LATIN SMALL LETTER I WITH ACUTE
U+00EE	î	LATIN SMALL LETTER I WITH CIRCUMFLEX
U+00EF	ï	LATIN SMALL LETTER I WITH DIAERESIS
U+00F0	ð	LATIN SMALL LETTER ETH
U+00F1	ñ	LATIN SMALL LETTER N WITH TILDE
U+00F2	ò	LATIN SMALL LETTER O WITH GRAVE
U+00F3	ó	LATIN SMALL LETTER O WITH ACUTE
U+00F4	ô	LATIN SMALL LETTER O WITH CIRCUMFLEX
U+00F5	õ	LATIN SMALL LETTER O WITH TILDE
U+00F6	ö	LATIN SMALL LETTER O WITH DIAERESIS
U+00F7	÷	DIVISION SIGN

Continued on page 57

Continued from page 56

Unicode Code Point	Character	Name
U+00F8	ø	LATIN SMALL LETTER O WITH STROKE
U+00F9	ù	LATIN SMALL LETTER U WITH GRAVE
U+00FA	ú	LATIN SMALL LETTER U WITH ACUTE
U+00FB	û	LATIN SMALL LETTER U WITH CIRCUMFLEX
U+00FC	ü	LATIN SMALL LETTER U WITH DIAERESIS
U+00FD	ý	LATIN SMALL LETTER Y WITH ACUTE
U+00FE	þ	LATIN SMALL LETTER THORN
U+00FF	ÿ	LATIN SMALL LETTER Y WITH DIAERESIS

Clean with Mild Detergent and Warm Water

Wipe down the device with a soft cloth dampened with a mild detergent and warm water solution. Do not use any other chemicals for cleaning.

Repairs

Contact Banner Engineering for troubleshooting of this device. **Do not attempt any repairs to this Banner device; it contains no field-replaceable parts or components.** If the device, device part, or device component is determined to be defective by a Banner Applications Engineer, they will advise you of Banner's RMA (Return Merchandise Authorization) procedure.

IMPORTANT: If instructed to return the device, pack it with care. Damage that occurs in return shipping is not covered by warranty.

Contact Us

Banner Engineering Corp. | 9714 Tenth Avenue North | Plymouth, MN 55441, USA | Phone: + 1 888 373 6767

For worldwide locations and local representatives, visit www.bannerengineering.com.

Banner Engineering Corp Limited Warranty

Banner Engineering Corp. warrants its products to be free from defects in material and workmanship for one year following the date of shipment. Banner Engineering Corp. will repair or replace, free of charge, any product of its manufacture which, at the time it is returned to the factory, is found to have been defective during the warranty period. This warranty does not cover damage or liability for misuse, abuse, or the improper application or installation of the Banner product.

THIS LIMITED WARRANTY IS EXCLUSIVE AND IN LIEU OF ALL OTHER WARRANTIES WHETHER EXPRESS OR IMPLIED (INCLUDING, WITHOUT LIMITATION, ANY WARRANTY OF MERCHANTABILITY OR FITNESS FOR A PARTICULAR PURPOSE), AND WHETHER ARISING UNDER COURSE OF PERFORMANCE, COURSE OF DEALING OR TRADE USAGE.

This Warranty is exclusive and limited to repair or, at the discretion of Banner Engineering Corp., replacement. **IN NO EVENT SHALL BANNER ENGINEERING CORP. BE LIABLE TO BUYER OR ANY OTHER PERSON OR ENTITY FOR ANY EXTRA COSTS, EXPENSES, LOSSES, LOSS OF PROFITS, OR ANY INCIDENTAL, CONSEQUENTIAL OR SPECIAL DAMAGES RESULTING FROM ANY PRODUCT DEFECT OR FROM THE USE OR INABILITY TO USE THE PRODUCT, WHETHER ARISING IN CONTRACT OR WARRANTY, STATUTE, TORT, STRICT LIABILITY, NEGLIGENCE, OR OTHERWISE.**

Banner Engineering Corp. reserves the right to change, modify or improve the design of the product without assuming any obligations or liabilities relating to any product previously manufactured by Banner Engineering Corp. Any misuse, abuse, or improper application or installation of this product or use of the product for personal protection applications when the product is identified as not intended for such purposes will void the product warranty. Any modifications to this product without prior express approval by Banner Engineering Corp will void the product warranties. All specifications published in this document are subject to change; Banner reserves the right to modify product specifications or update documentation at any time. Specifications and product information in English supersede that which is provided in any other language. For the most recent version of any documentation, refer to: www.bannerengineering.com.

For patent information, see www.bannerengineering.com/patents.

