

Inductive Sensing Design Guide

Authors: Paul Walsh, Dineshababu Mani

Associated Part Family: PSoC® 4700

Software Version: PSoC Creator™ 4.2 or later

Related Application Notes: For a complete list, [click here](#).

More code examples? We heard you.

To access an ever-growing list of hundreds of PSoC code examples, please visit our [code examples webpage](#). You can also explore the PSoC video library [here](#).

AN219207 shows how to implement inductive sensing using PSoC® 4700 MCU family and tune it for desired performance. Inductive sensors are based on the principle of magnetic induction and are used for detecting non-contact position of target metal. Cypress inductive sensing solutions bring elegant, reliable, and easy-to-use inductive sensing functionality to your product.

Contents

1	Introduction.....	2	7.2	Refresh Rate.....	24
1.1	PSoC 4700 Inductive Sensing Features	2	8	Related Application Notes	24
2	Inductive Sensing Overview	2	9	Bibliography.....	24
3	Designing an Inductive Sensing System	3	Appendix A.	Sensor Design	25
4	Use Cases of MagSense.....	6	A.1	Sensor Resonant Frequency (f_0).....	25
4.1	Design Inductive Proximity Sensing System.....	6	A.2	R_P and R_S Range.....	25
4.2	Design Metal Over Touch (MoT) System.....	8	A.3	Sensor Shape	27
4.3	Design Rotary Encode System	10	A.4	Sensor Parameters.....	29
5	Tuning MagSense Component Parameters	13	A.5	Sensor Dimensions.....	29
5.1	Getting Started with MagSense	13	A.6	Sensor Modeling.....	30
5.2	MagSense Tuning Flow	15	A.7	Sensors with Multiple Layers	31
5.3	Set MagSense Parameters.....	16	A.8	Sensor Layout Guidelines.....	32
5.4	Ensure SNR Is Greater Than or Equal to 5:1	17	A.9	Hardware Considerations	33
5.5	Set Optimum Threshold Parameters.....	18	A.10	Sensor Design Spreadsheet	34
5.6	Design Debug	20	A.10.1	Tuning Calculator	34
6	Additional Firmware Filters to Reduce Noise.....	20	A.10.2	Simple Coil Designer	35
6.1	Advanced Low-Pass (ALP) Filter	20	A.10.3	Metal Deflection Estimator	36
7	Other System Design Considerations.....	22	Appendix B.	Reading Sensor Debug Data in	
7.1	Dynamic Power Consumption.....	22		Bridge Control Panel	37

1 Introduction

Inductive sensing is a low-cost, robust solution that seamlessly integrates with existing user interfaces, and is also used to detect the presence of metallic or conductive objects.

This application note helps you understand:

- [Inductive Sensing Overview](#)
- [Designing an Inductive Sensing System](#)
- [Use Cases of MagSense](#)
- [Tuning MagSense Component Parameters](#)

This guide assumes that you are familiar with developing applications for PSoC 4 MCUs using the Cypress PSoC Creator integrated design environment (IDE). If you are new to PSoC 4, see [AN79953, Getting Started with PSoC® 4](#).

1.1 PSoC 4700 Inductive Sensing Features

Inductive sensing in the PSoC 4700 MCU has the following features:

- Supports inductive sensing for excitation frequencies up to 3 MHz
- Operates at a measurement rate of up to 10 ksp/s
- Supports up to sixteen inductive sensor channels.
- Contains an integrated graphical tuner for tuning, testing, and debugging

2 Inductive Sensing Overview

Inductive sensing works on the principle of electromagnetic coupling between a sensor coil and the metal target to be detected. When the metal target enters the electromagnetic field induced by a sensor coil, some of the electromagnetic energy is transferred into the metal target as shown in [Figure 1](#). This transferred energy causes a circulating electrical current called an eddy current. The eddy current flowing in the metal target induces reverse electromagnetic field on the sensor coil, which results in a reduction of the effective inductance of the sensor coil.

The sensor coil is placed in parallel with a capacitor. The parallel combination of sensor inductance and the external capacitor is called a tank circuit. The reduction in the sensor coil inductance causes an upward shift in the resonant frequency of the tank circuit. This shift in resonant frequency changes the amplitude of the signal across the sensor coil. The change in the amplitude of the sensor coil signal is measured by the PSoC 4 MCU to detect the presence of the metal target in the proximity-sensing distance. Note that the inductance of the sensor coil increases in the presence of ferromagnetic metal targets. An increase in the sensor inductance causes a down shift in the resonant frequency of the tank circuit.

Figure 1. Field Coupling Between Sensor and Metal Target

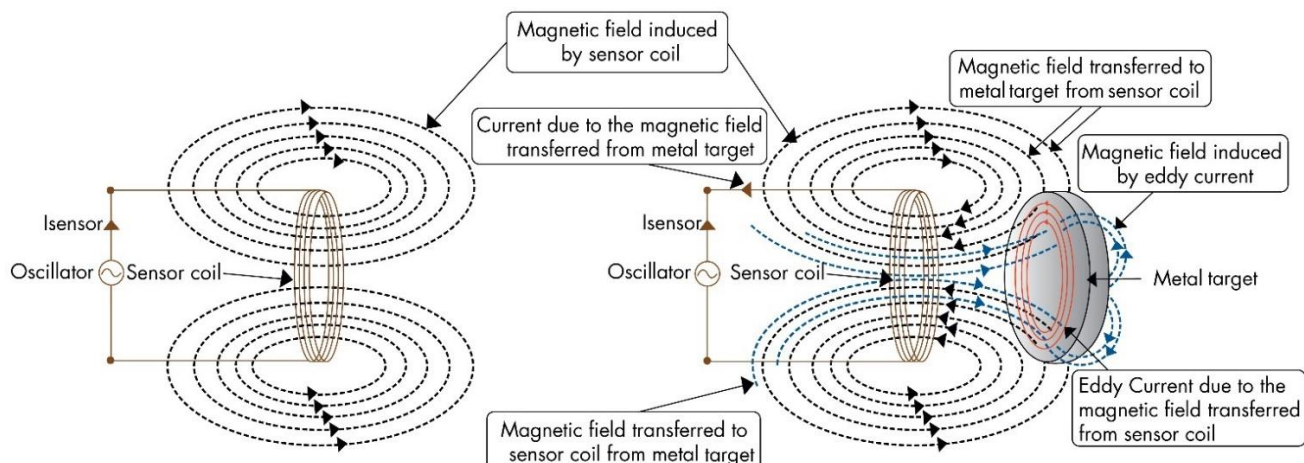

PRELIMINARY

Typical applications for inductive sensing include the following:

- Proximity detection
- Replacing mechanical open/close switches
- Buttons (industrial keypads and ON/OFF buttons)
- Rotation detection (flow meters, fan speed RPM detection, rotary control knob)
- Linear Encoder
- Spring compression detection

3 Designing an Inductive Sensing System

This section provides an overview of designing an inductive-sensing system. A block diagram of the inductive sensing system using a PSoC 4700 MCU is shown in Figure 2. A capacitor (C) is placed in parallel with the coil to create a parallel LC 'tank'. The tank has a resonant frequency provided by the following equation:

$$f_0 = \frac{1}{2\pi \sqrt{LC}} \tag{1}$$

Figure 2. Block Diagram of the Inductive Sensing System with a PSoC 4700 MCU

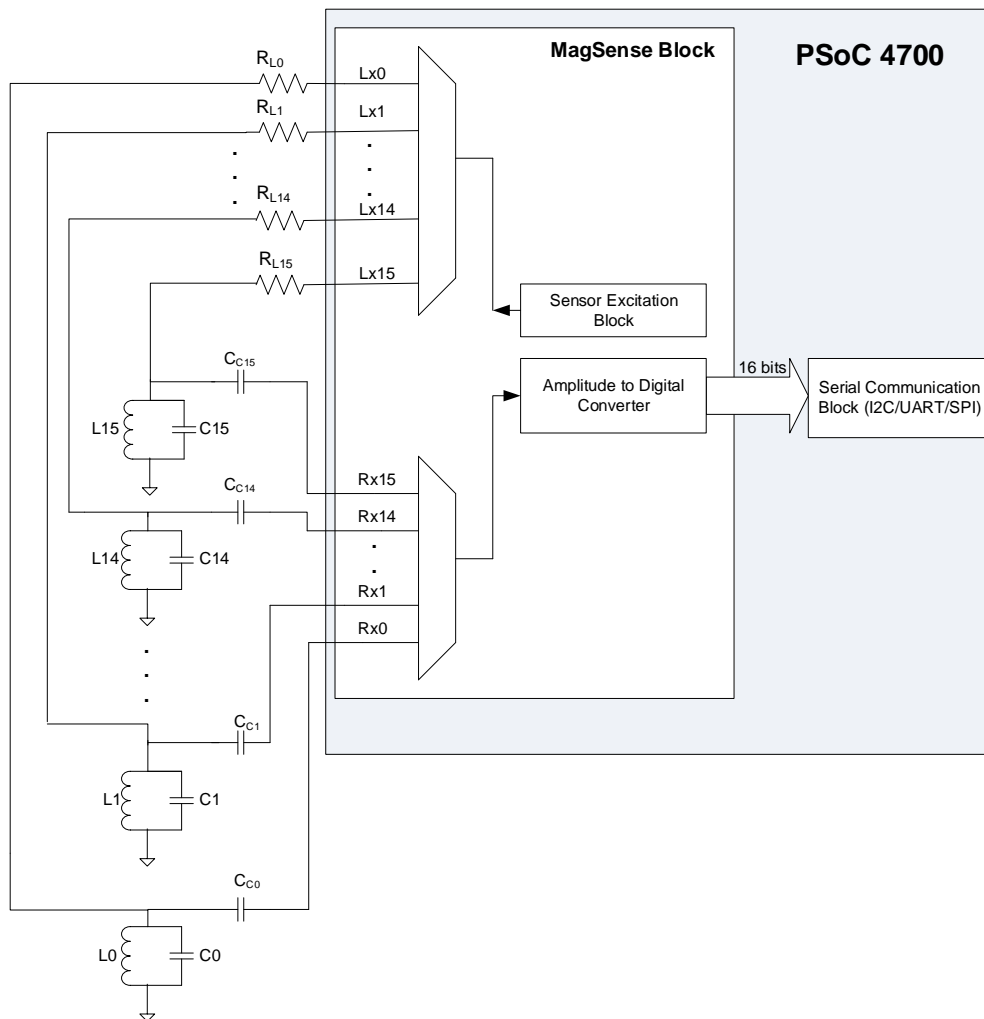

The frequency of the Lx GPIO (sensor excitation pin) is set to the resonant frequency of the tank (f_0). This pin then drives the tank circuit through a resistor, R_{Lx} . The impedance of the tank circuit is the maximum at the resonant frequency, so a significant sinusoidal component with amplitude V_{AMP} (peak) appears across the tank circuit. This signal is AC-coupled into the Amplitude to Digital Converter through the capacitance C_C as shown in [Figure 2](#) and is then converted into equivalent raw count. A change in inductance of the LC tank causes a change in V_{AMP} resulting in a change in the raw count of corresponding channels.

This system has the advantage that it excites the tank circuit to a known frequency. Multiple tanks can be set to resonate at different frequencies. Also, the frequency of operation of the tank circuit is controlled and can be designed for the best EMC performance.

The practical coil impedance is represented as an Inductance (L) with a series resistor (R_s) as shown in [Figure 3](#).

Figure 3. LC Tank Resonance Circuit

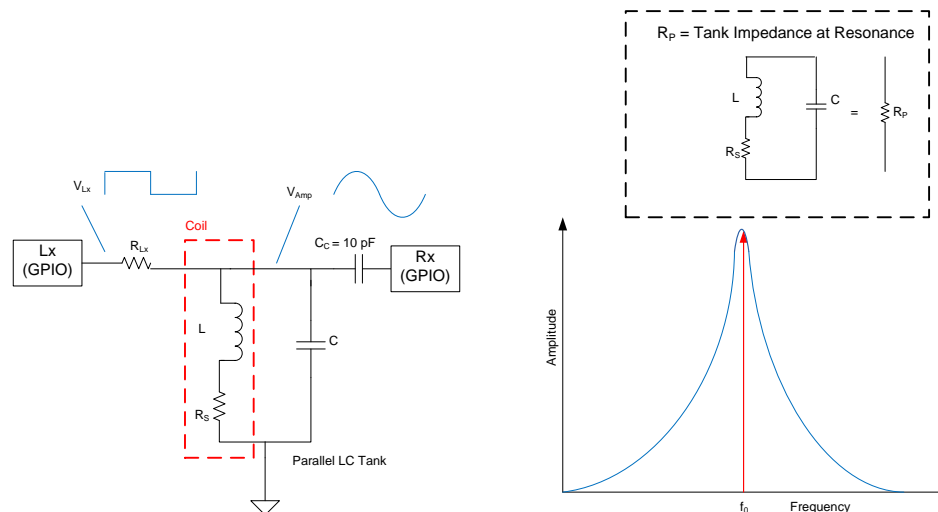

[Figure 4](#) shows the steps for designing an inductive sensing system.

1. **Determine the design/size the coil:** Designing and sizing the coil required for your application is important. See [Appendix A Sensor Design](#) for further details.
2. **Determine/measure the inductance (L) and AC resistance (R_s) of the coil:** The coil inductance and AC resistance at a specific frequency can be measured with an LCR meter or estimated using a 2-D / 3-D coil modeling simulator. See section [A.6.2](#) for example simulators. See the [Sensor Design Spreadsheet](#) section to calculate L and R_s .
3. **Choose C and f_0 :** The resonant frequency of the tank (f_0) is set by Equation [2] considering the effect of AC resistance (R_s) of the coil. To select the resonant frequency, considering the coil parameters as well as the refresh rate and power consumption is important. Select the resonant frequency (f_0) in the range of 45 kHz to 3 MHz and select a discrete capacitance (C) that satisfies Equation [2].

$$f_0 = \frac{1}{2\pi} \sqrt{\frac{1}{LC} - \left(\frac{R_s}{L}\right)^2} \quad [2]$$

4. **Determine the equivalent tank impedance (R_p) at resonance:** The impedance of the tank at resonance is required to determine R_{Lx} , the resistor in series with Lx pin. Use Equation [3] to estimate the value of R_p . See section [A.2.1](#) for the details of R_s , the AC series resistance of coil.

$$R_p = \frac{1}{R_s} (2\pi f_0 L)^2 \quad [3]$$

5. **Determine R_{Lx} and C_c :** The value of R_{Lx} can be found by substituting Equation [3] with Equation [4]. The value of C_c can be chosen based on the value of V_{AMP} . See [Table 1](#) to select C_c . Higher value of V_{AMP} provides better SNR.

$$R_{Lx} = R_p * \left(\frac{V_{DDA}}{V_{AMP}} - 1 \right)$$

[4]

Where V_{DDA} = power supply voltage.

 Table 1. Selection of C_C

V_{AMP} (V)	C_C (pF)
0.6	33
1.2	22
1.8	10

See [Tuning Calculator](#) to calculate the values of R_{Lx} and C_C .

6. **Set f_0 in the MagSense™ Component:** Set the value of f_0 from Equation [2] in the [MagSense Component](#).
7. **Tune the prototype:** Tune the prototype board to achieve the required performance. See [Tuning MagSense Component Parameters](#) for more details. After tuning the sensor, check whether the inductive sensor performance meets your requirements. If the requirements are met, proceed to [Step 9](#); otherwise continue with [Step 8](#).
8. **Re-tune or redesign if necessary:** If the inductive sensor does not provide the required performance after you have set the optimum parameters, increase the sensor size or reduce the noise in the system by shielding the sensor from noise sources and repeat [Step 7](#).
9. **End:** If the Inductive sensor meets the required performance, integrate it with your product.

Figure 4. Tuning Flow for Inductive Sensing Applications

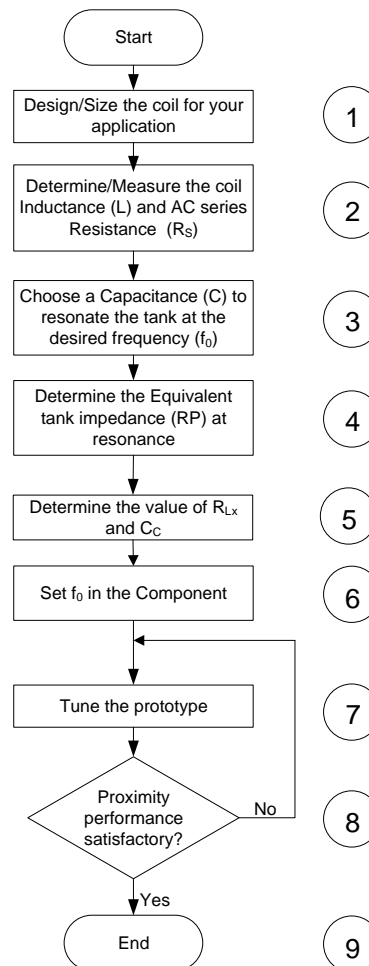

4 Use Cases of MagSense

This section discusses the following use cases of MagSense based on PSoC 4700 MCU:

- Proximity Sensing
- Metal over Touch
- Rotary Encoder

4.1 Design Inductive Proximity Sensing System

The recommended sensor design flow for proximity application is outlined in [Figure 5](#).

Figure 5. Sensor Design Flow

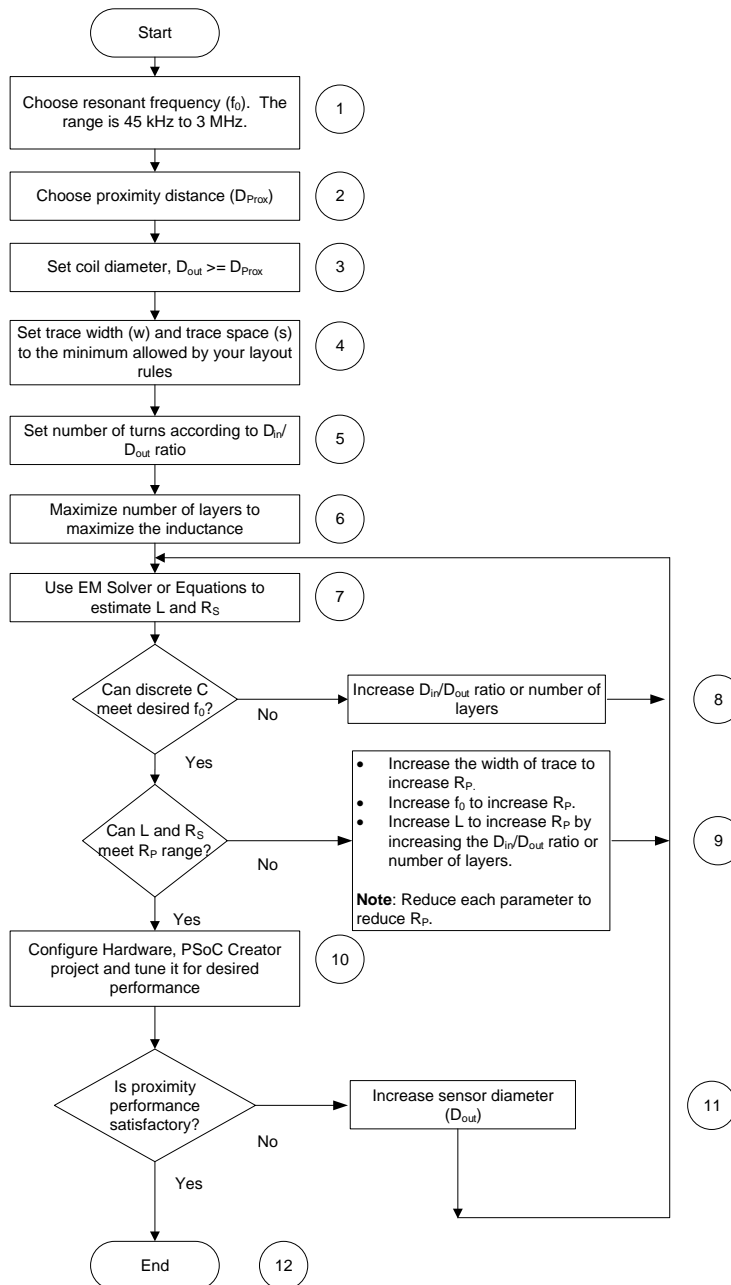

The detail of each step, shown in [Figure 5](#) is outlined as follows:

1. **Choose f_0 :** Choose the resonant frequency that best suits the system. The supported range is 45 kHz to 3 MHz.
2. **Choose proximity-sensing distance:** Determine the proximity-sensing distance (D_{prox}) needed by the system.
3. **Choose the Coil Diameter:** Set the coil diameter (D_{out}) to be greater than or equal to D_{prox} .
4. **Set Trace Width/Space:** Set the trace width (w) and space (s) to a minimum for the PCB design technology you are using.
5. **Set the number of turns:** Set the number of turns according to the D_{in}/D_{out} ratio that you need. A guideline is to set $D_{in}/D_{out} > 0.3$. A higher ratio will decrease L , but can improve sensitivity when sensing objects that are at a distance of the coil diameter from the coil.
6. **Maximize the number of layers:** Setting the number of layers to a maximum and choosing a series connection between layers will maximize the inductance and therefore, maximizes R_P to reduce coil loss.
7. **Calculate L and R_s :** Calculate the inductance (L) and the AC series resistance (R_s) at the resonant frequency (f_0) by using either an EM solver or Equations [19] and [20]. See the [Sensor Design Spreadsheet](#) section to calculate L and R_s .
8. **Optimize L :** Determine whether the value of L satisfies the chosen f_0 using Equation [2] for an available discrete capacitance, C . If not, you should optimize the D_{in}/D_{out} ratio or the number of layers.
9. **Optimize R_P :** Calculate R_P from Equation [3]. If it does not satisfy the R_P range of 350 to 50,000 (see [Figure 25](#)) consider the following:
 - a. **Increase R_P :** Increase R_P by increasing w , s , f_0 , or L .
 - b. **Decrease R_P :** Decrease R_P by decreasing w , s , f_0 , or L .
10. **Configure Hardware, PSoC Creator project, and tune it for desired performance:** Configure the hardware. Create a PSoC Creator project and tune it for desired performance. See the [Tuning MagSense Component Parameters](#) section to optimize SNR.
11. **Check the proximity-sensing distance:** Measure the proximity-sensing distance. If the proximity performance is not satisfactory, consider increasing the diameter of the sensor.
12. **End:** The proximity-sensing performance is satisfactory.

4.1.1 Sensor Self-Resonant Frequency (f_{SR})

The inductor itself has a parasitic capacitance due to the inter-winding capacitance of the coil. At a certain frequency, this parasitic capacitance resonates with the sensor inductance. A rule of thumb is to keep the sensor frequency (f_0) less than three times lower than the self-resonant frequency (f_{SR}) of the coil.

$$f_0 < 3 \cdot f_{SR} \quad [5]$$

The self-resonant frequency can be measured with an impedance meter.

4.1.2 Additional Considerations

As a designer, you may require additional tuning when implementing inductive sensing:

- **Achieving a large distance:** A larger distance is achievable with a larger diameter coil.
- **Tuning R_{LX} for correct tank amplitude:** The tank amplitude (V_{AMP}) is determined by R_P of the tank at resonance and R_{LX} , the drive resistance. If the measured tank amplitude differs from the calculated value, then R_{LX} can be changed to bring the amplitude back to meet expectations. As the first step, use Equation [6] to estimate the actual R_P (R_{P_ACT}). Next, put the R_{P_ACT} value into Equation [7] to estimate the new value for R_{LX} .

$$R_{P_ACT} = \frac{V_{AMP_ACT} \cdot R_{LX}}{(V_{DDA} - V_{AMP_ACT})} \quad [6]$$

Where,

R_{P_ACT} = actual (measured) value of R_P

V_{AMP_ACT} = actual (measured) tank amplitude

VDDA = power supply voltage

$$R_{Lx_New} = R_{P_ACT} \left(\frac{V_{DDA} - V_{AMP}}{V_{AMP}} \right)$$

[7]

R_{Lx_{New}} = new value of R_{Lx}

V_{AMP} = desired tank amplitude

4.2 Design Metal Over Touch (MoT) System

Metal over Touch (MoT) involves detecting the deflection of a metal overlay upon a touch. MoT uses a metal overlay separated from the sensor using a thin spacer or etched surfaces of metal overlay as shown in Figure 6. When you touch the metal, the metal deflects. This deflection is detected by the inductive sensor. Figure 7 shows an example of front and back (with etched cavities) of a metal overlay. The sensitivity of touch detection depends on the following parameters.

- Amount of metal deflection
- Sensor dimensions
- Spacer thickness or depth of etched cavity
- Applied force

Note that the amount of metal deflection for the applied force depends on metal material, thickness, and flexural rigidity.

Figure 6. Metal Over Touch Arrangement

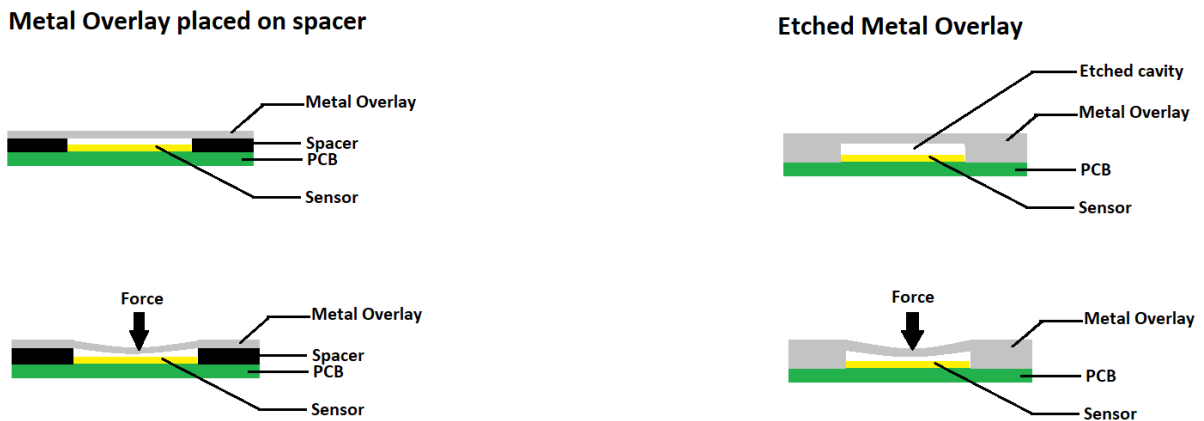
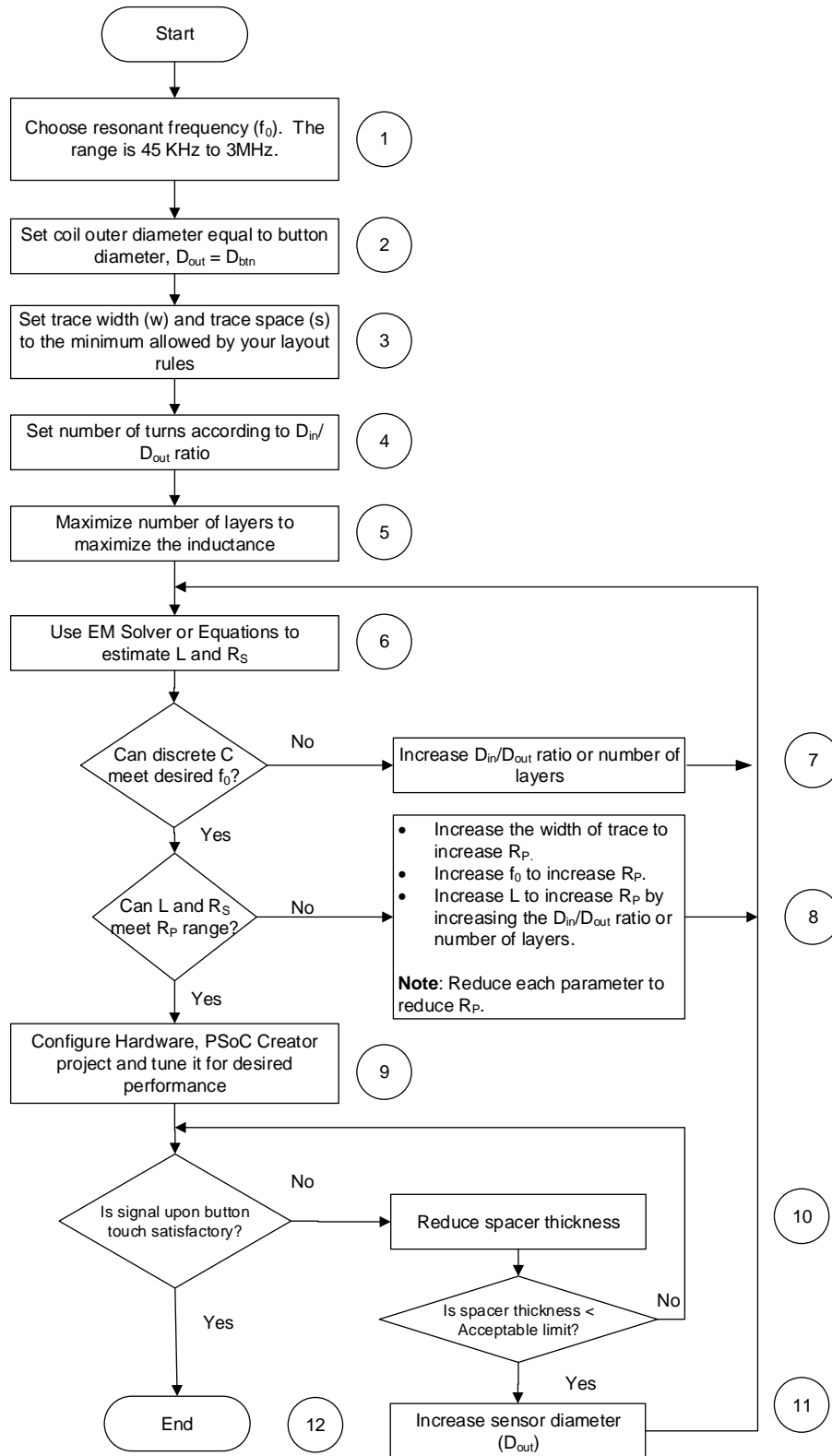

Figure 7. Example Metal Overlay



The design of MoT involves the design of the sensor and the mechanical placement of the metal overlay. The sensor design flow is shown in Figure 8.

Figure 8. Sensor Design Flow of MoT



PRELIMINARY

1. **Choose f_0 :** Choose the resonant frequency that best suits the system. The supported range is 45 kHz to 3 MHz.
2. **Choose the Coil Diameter:** Set the coil diameter (D_{out}) to be equal to button diameter D_{btn} .
3. **Set Trace Width/Space:** Set the trace width (w) and space (s) to a minimum for the PCB design technology you are using.
4. **Set the number of turns:** Set the number of turns according to the D_{in}/D_{out} ratio that you need. A guideline is to set $D_{in}/D_{out} > 0.3$.
5. **Maximize the number of layers:** Set the number of layers to a maximum and choose a series connection between layers to maximize the inductance and therefore, maximize R_P to reduce coil loss.
6. **Calculate L and R_s :** Calculate the inductance (L) and the AC series resistance (R_s) at the resonant frequency (f_0) by using either an EM solver or Equations [19] and [20]. See the [Sensor Design Spreadsheet](#) section to calculate L and R_s .
7. **Optimize L:** Determine whether the value of L satisfies the chosen f_0 using Equation [2] for an available discrete capacitance, C. If not, you should optimize the D_{in}/D_{out} ratio or the number of layers.
8. **Optimize R_P :** Calculate R_P from Equation [3]. If it does not satisfy the R_P range of 350 to 50,000 (see [Figure 25](#)) consider the following:
 - a. **Increase R_P :** Increase R_P by increasing w , s , f_0 , or L
 - b. **Decrease R_P :** Decrease R_P by decreasing w , s , f_0 , or L
9. **Configure Hardware, PSoC Creator project, and tune it for desired performance:** Configure the hardware. Create a PSoC Creator project and tune it for desired performance. See the [Tuning MagSense Component Parameters](#) section to optimize SNR.
10. **Check the touch performance:** Measure the signal upon button touch and SNR. If the button performance is not satisfactory, consider reducing the spacer thickness.
11. **Increase sensor diameter:** If the spacer thickness becomes less than the acceptable limit, consider increasing the sensor diameter D_{out} and measure the performance of button touch.
12. **End:** The button performance is satisfactory.

4.3 Design Rotary Encode System

Rotary Encode is another use case for inductive sensing. This section discusses the design of inductive rotary encoder. The construction of rotary encoder involves two sensor coils and N number of targets placed on the rotating platform as shown in [Figure 9](#).

Figure 9. Construction of Inductive Rotary Encoder

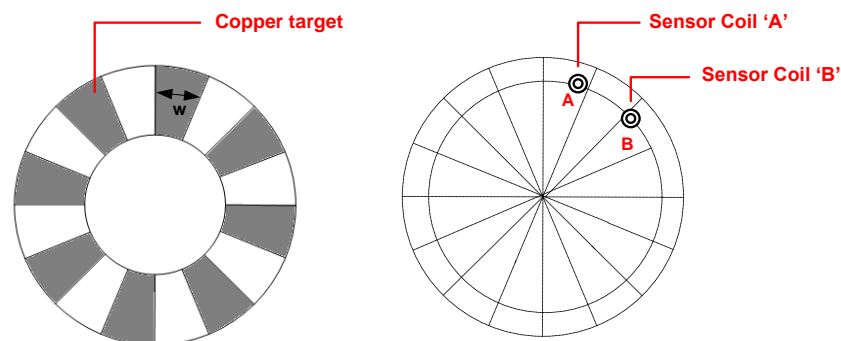

The number of targets (N) decides the angular resolution as shown in Equation [8].

$$\text{Angular resolution} = \frac{360}{(N * 4)} \quad [8]$$

The sensor coils need to be separated at an angle twice the angular resolution. For example, if the number of targets $N = 8$, then the achievable angular resolution is 11.25° and the required spacing between sensor coils is 22.5° . The direction of rotation can be determined using the previous value of coil 'A' and the current value of coil 'B' as shown in [Table 2](#). If the current value of coil 'B' and previous value of coil 'A' are same, it means the direction of rotation is anti-clockwise direction; if the values are different, then is the direction of rotation is clockwise.

Table 2. Direction of Rotation

Clockwise Direction		Anti-clockwise Direction	
A	B	A	B
1	1	1	1
1	0	0	1
0	0	0	0
0	1	1	0

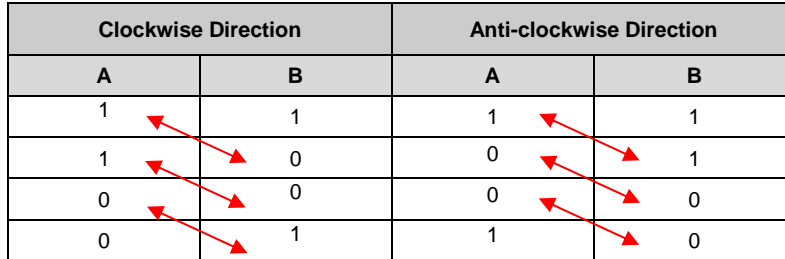

The sensor design flow of inductive rotary encoder is provided in [Figure 10](#).

Figure 10. Inductive Rotary Encoder – Sensor Design Flow

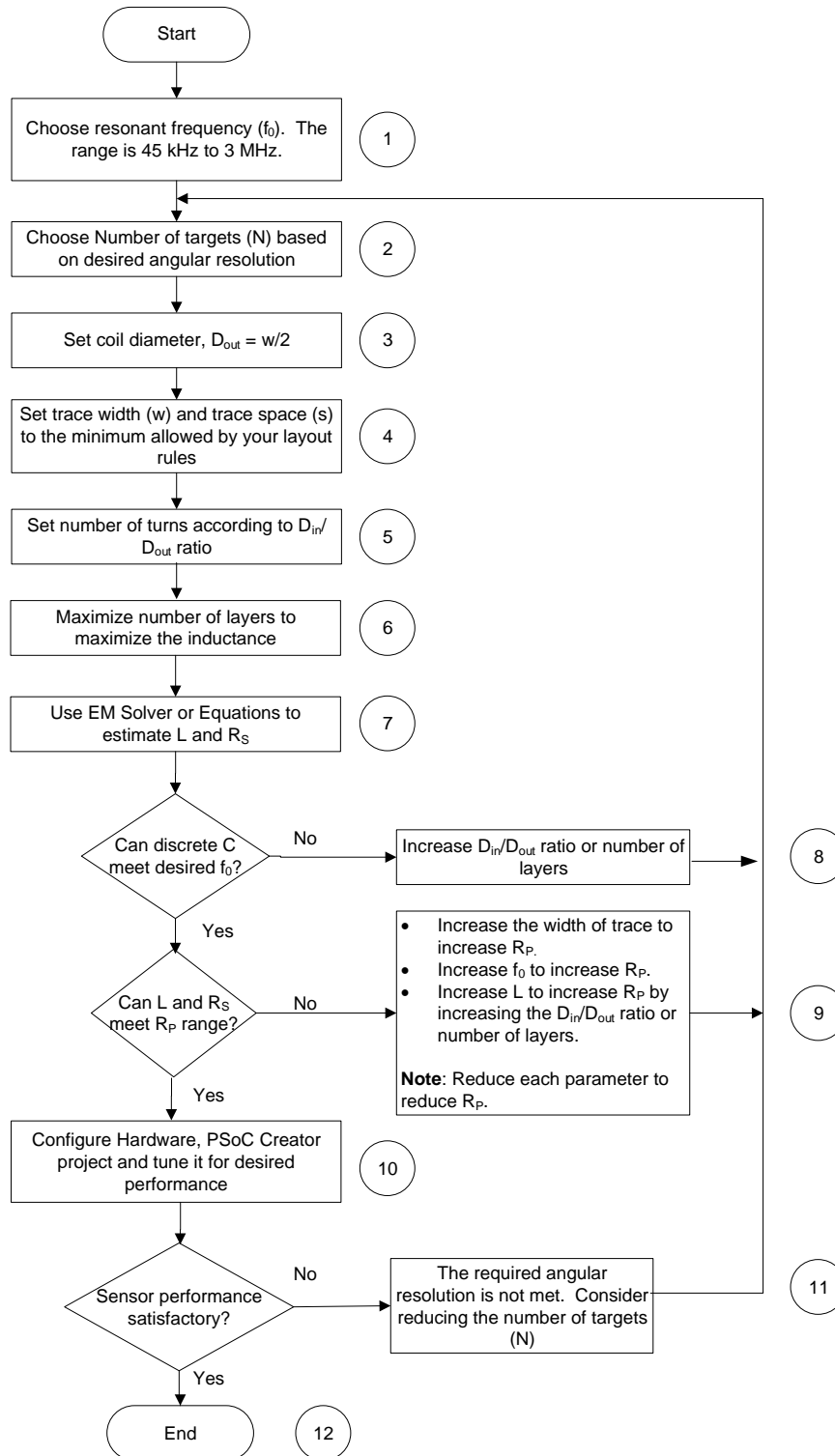

1. **Choose f_0 :** Choose the resonant frequency that best suits the system. The supported range is 45 kHz to 3 MHz.
2. **Choose Number of targets:** Determine the number of targets (N) required to meet the desired angular resolution.

3. **Choose the Coil Diameter:** Set the coil diameter (D_{out}) to be equal to half of mean width of one target.
4. **Set Trace Width/Space:** Set the trace width (w) and space (s) to a minimum for the PCB design technology you are using.
5. **Set the number of turns:** Set the number of turns according to the D_{in}/D_{out} ratio that you need. A guideline is to set $D_{in}/D_{out} > 0.3$.
6. **Maximize the number of layers:** Set the number of layers to a maximum and choose a series connection between layers and maximize the inductance and therefore, maximize R_P to reduce coil loss.
7. **Calculate L and R_S :** Calculate the inductance (L) and the AC series resistance (R_S) at the resonant frequency (f_0) by using either an EM solver or Equations [19] and [20]. See the [Sensor Design Spreadsheet](#) section to calculate L and R_S .
8. **Optimize L:** Determine whether the value of L satisfies the chosen f_0 using Equation [2] for an available discrete capacitance, C . If not, you should optimize the D_{in}/D_{out} ratio or the number of layers.
9. **Optimize R_P :** Calculate R_P from Equation [3]. If it does not satisfy the R_P range of 350 to 50,000 (see [Figure 25](#)) consider the following:
 - a. **Increase R_P :** Increase R_P by increasing w , s , f_0 , or L .
 - b. **Decrease R_P :** Decrease R_P by decreasing w , s , f_0 , or L .
10. **Configure Hardware, PSoC Creator project and tune it for desired performance:** Configure the hardware. Create a PSoC Creator project and tune it for desired performance. See the [Tuning MagSense Component Parameters](#) section to optimize SNR.
11. **Check the sensor performance:** Measure the sensor signal. If the sensor does not yield significant signal change in the presence of the target, the desired angular resolution is not met; consider reducing the number of targets.
12. **End:** The system meets desired performance.

5 Tuning MagSense Component Parameters

After you have completed the inductive proximity sensor design and layout, the next step is to implement the firmware and tune the MagSense Component parameters to achieve optimum performance. PSoC Creator provides an inductive sense Component to simplify system design. See the [MagSense Component datasheet](#) for more details.

To detect a slight change in inductance, the MagSense circuitry should be tuned for high sensitivity, and the threshold parameters should be set to optimum values.

Tuning an inductive sensor in PSoC Creator has four high-level steps:

1. [Getting Started with MagSense](#)
2. [MagSense Tuning Flow](#)
3. [Set MagSense Parameters](#)
4. [Set Optimum Threshold Parameters](#)

5.1 Getting Started with MagSense

1. **Add an MagSense Component to your schematic.**

In the PSoC Creator *TopDesign.cysch* window, search for the MagSense Component ([Figure 12](#)) and drop it onto your schematic.

2. **Add an inductive sensor to your design.**

In the PSoC Creator *TopDesign.cysch* window, double-click the MagSense Component to configure the parameters. Starting with the basic configuration window shown in [Figure 13](#), add a widget by clicking + under **Type** in the basic window. Currently the MagSense Component has three widgets - Button, Proximity Sensor, and Encoder Dial.

3. **Set the inductive sensor settings of the MagSense Component.**

The settings are explained in [Table 4](#). It is recommended to set the modulator clock (clock to Amplitude to Digital Converter) to maximum value.

4. **Set the widget parameters in the MagSense Component.**

The Widget details window is shown in [Figure 15](#). Here, the Lx clock frequency (sensor excitation frequency) and number of sub-conversion parameters are set. The **Widget Threshold** parameters are described in the [Set Optimum Threshold Parameters](#) section of this document.

The **Lx clock frequency** must be set to the resonant frequency of the tank circuit. [Figure 11](#) illustrates the relationship between Modulator Clock, Lx Clock, and Sub-conversions (number of conversions per data sample).

Figure 11. Lx Clock, Modulator Clock, and Number of Subconversions Relationship

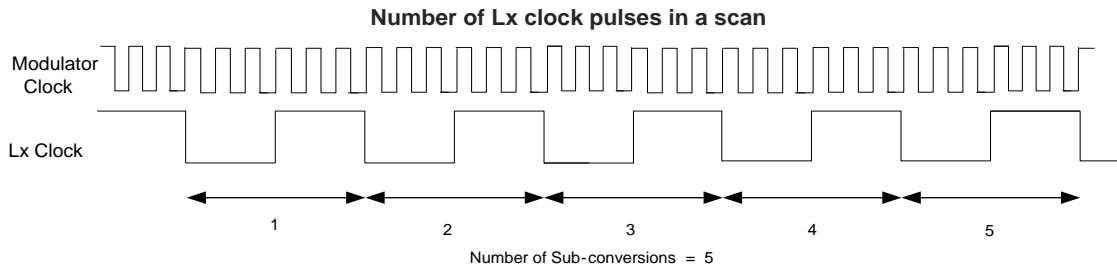

The Number of sub-conversions determines the sensitivity of the sensor.

$$\text{Number of Subconversions} < \left\{ \frac{2^{16} \cdot \text{Lx clock}}{\text{Modulator clock}} \right\} \quad [9]$$

5. **Scan Order**

The **Scan Order** tab ([Figure 15](#)) shows the order in which the widgets are scanned. An estimate of the total scan time is given in the lower right corner of this window.

Figure 12. Inductive Sense Component

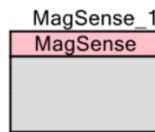

Figure 13. Basic Configuration Window

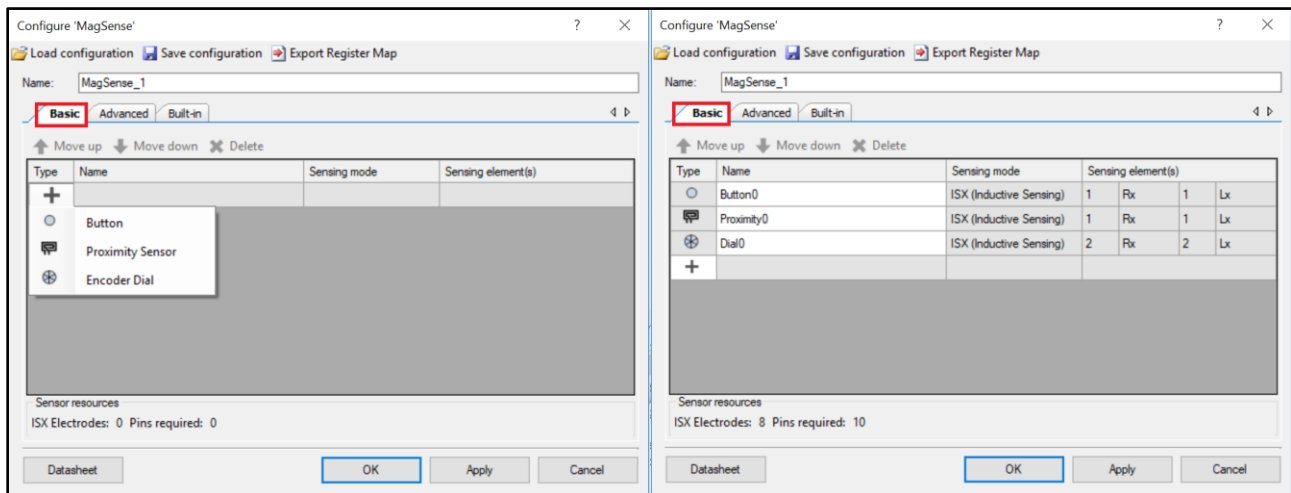

Figure 14. General and ISX (MagSense Crosspoint) Settings Configuration

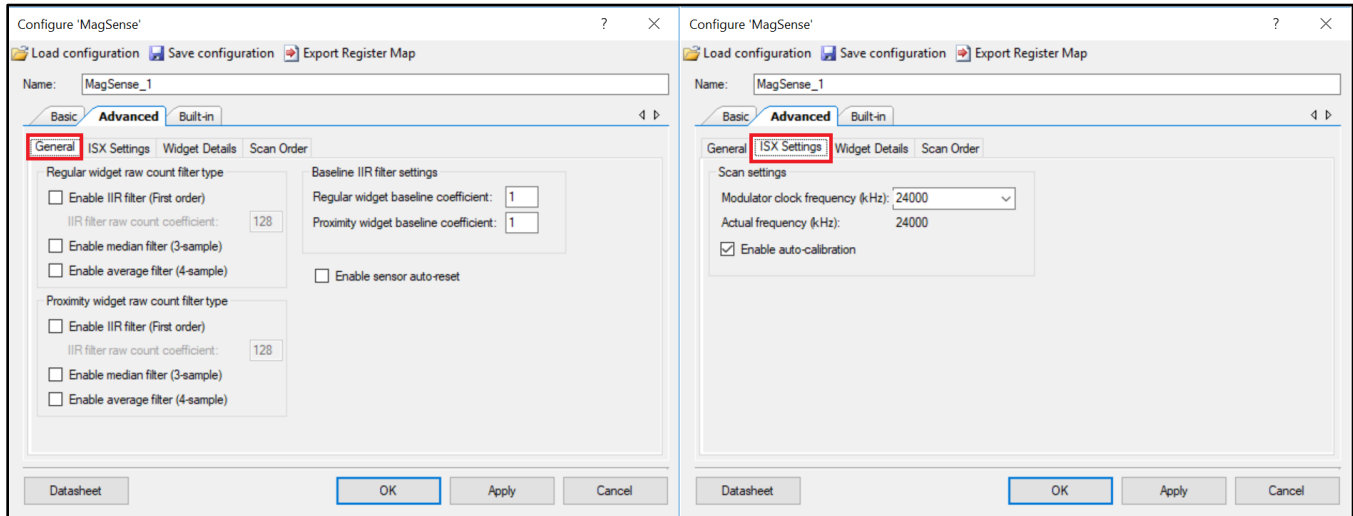
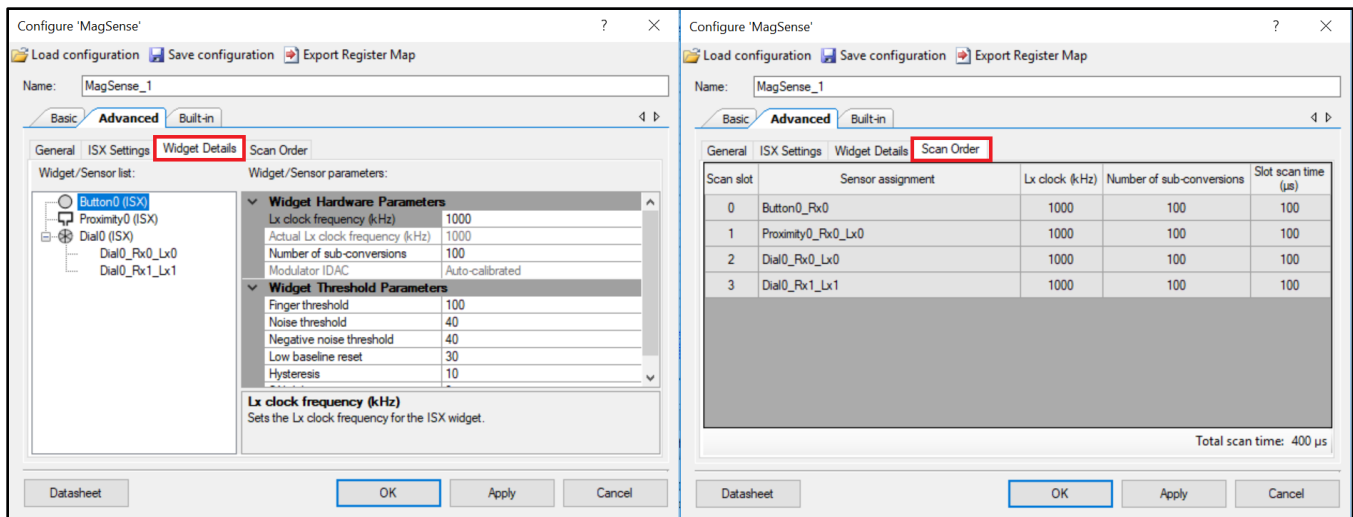

Figure 15. Widget Details and Scan Order Configuration



5.2 MagSense Tuning Flow

The inductive sensing tuning flow is shown in [Figure 16](#).

1. **Set ISX Tuning parameters:** Set the tuning parameters outlined in the [Getting Started with MagSense](#) section. The most critical parameters are the Lx clock frequency and the number of sub-conversions, the number of conversions per data sample. Ensure that the Lx clock frequency is set to the resonant frequency of the LC tank (f_0).
2. **Measure SNR:** See [Ensure SNR Is Greater Than or Equal to 5:1](#). If the SNR measured is greater than or equal to 5:1, proceed to Step 5; otherwise, enable filters and measure the SNR again.
3. **(SNR < 5:1) Enable FW filters or increase the number of sub-conversions:** See [Table 3](#).

Simple filters such as median, average, and infinite impulse response (IIR) filters may not be able to attenuate the higher noise amplitude in sensors, so you may need to use the advanced low-pass filter (ALP filter). The ALP filter is designed specifically for attenuating noise in the inductive sensor and providing a fast response time. See [Advanced Low-Pass \(ALP\) Filter](#).

4. **Max sub-conversions/All filters used:** If all filters are enabled and the number of sub-conversions is set to a maximum, defined by Equation [9], debug is required to determine the reasons for the design not meeting $SNR \geq 5:1$. See [Design Debug](#).
5. **($SNR \geq 5:1$) System meets timing:** If $SNR \geq 5:1$, it is important to check whether the system meets timing requirements. You might need to reduce the number of sub-conversions or remove filters if the SNR and scan time are high.
6. **Set the system thresholds:** After the scan time and SNR meet requirements, it is important to set the firmware thresholds for optimum detection of the target. See the following:
 - [Table 6](#) for a list of these thresholds.
 - [Figure 18](#) for a graphical representation of each threshold.
 - The [Set Optimum Threshold Parameters](#) section for optimum values for each threshold.

Figure 16. Inductive Sensing Tuning Flow

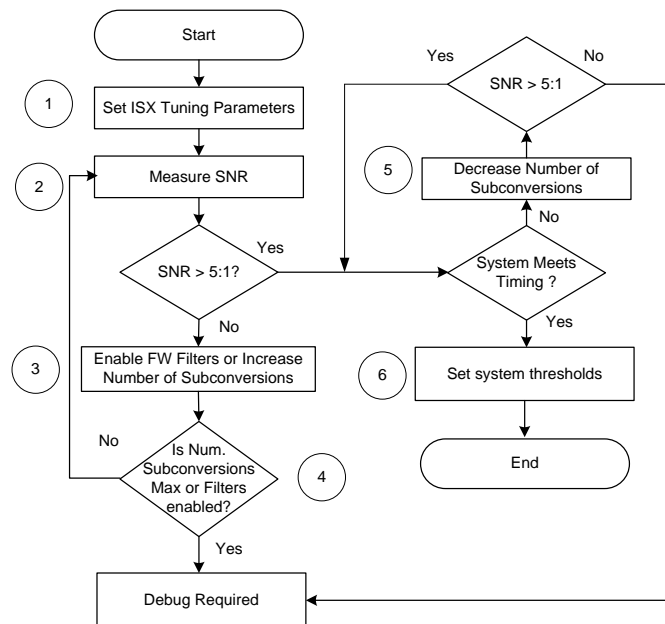

5.3 Set MagSense Parameters

Inductive sense parameters in each of the Widget windows are described in [Table 3](#).

Table 3. MagSense Component General Configuration Parameters

Parameter	Value	Details
Proximity/Regular Widget raw count filter type	Median, Average, or IIR	<ol style="list-style-type: none"> 1. Median Filter: A nonlinear filter that takes the three most recent samples and computes the median. $y[i] = \text{median}(x[i], x[i - 1], x[i - 2])$ 2. Average Filter: Takes the four most recent samples and computes the average. $y[i] = \frac{1}{4}(x[i] + x[i - 1] + x[i - 2] + x[i - 3])$ 3. First Order IIR Filter: This filter has a step response similar to an RC low-pass filter, passing low-frequency signals from the sensor. The K value is fixed as 256. N is the IIR filter raw count coefficient. A lower N value results in lower noise. $y[i] = \frac{1}{K}(N \cdot x[i] + (K - N) \cdot y[i - 1])$
IIR filter raw count coefficient	1 to 128	This parameter is the value N in the First Order IIR filter equation above.

Table 4. MagSense Component ISX Parameters

Parameter	Value	Details
Modulator Clock	48 MHz	The modulator clock drives the MagSense system and should be set to 48 MHz. Make sure to set HFCLK to 48 MHz in Design Wide Resources.
Auto Calibration	Enabled	Enable auto-calibration of the RX (recommended).

Table 5. MagSense Component Widget Details Configuration Parameters

Parameter	Value	Details
LX Clock Frequency	3 MHz	The LX clock can be set in the range from 45 kHz to 3 MHz; this must match the resonant frequency of the tank.
Num. of Sub-conversions	100	The number of sub-conversions defines the overall resolution that is measured. The higher the value, the higher is the resolution, but also the longer the response time. See Equation [9].
Finger threshold ¹	100	This threshold sets the touch level to determine the sensor state based on the signal.
Proximity threshold	100	This threshold detects the presence of a metal target at distance. This gives a proximity-sensing distance threshold.
Touch threshold	200	This is a second threshold used to detect the presence of a metal target within close proximity to the sensor coil
Noise threshold	40	The noise threshold decides whether the baseline is updated: If the signal is below the noise threshold, the baseline is updated. If the signal is above the noise threshold, the baseline is not updated.
Negative noise threshold	40	The negative noise threshold sets the raw count limit below which the baseline is not updated for the number of samples specified by the low baseline reset parameter.
Low baseline reset	30	Along with the negative noise threshold, this parameter counts the number of abnormally low raw counts required to reset the baseline.
Hysteresis	15	Hysteresis sets limits around the touch threshold within which the sensor is considered ON or OFF. See the description of the 'ON debounce' parameter for more details.
ON debounce	3	Debounce sets the number of consecutive scans during which a sensor must be active to generate an ON state from the component: $Sensor\ State \begin{cases} PROX\ ON, & \text{if } (signal \geq Proximity\ threshold + Hysteresis) \geq debounce \\ PROX\ OFF, & \text{if } (signal \leq Proximity\ threshold - Hysteresis) \\ PROX\ OFF, & \text{if } (Signal \geq Proximity\ threshold + Hysteresis) < debounce \end{cases}$ $Sensor\ State \begin{cases} TOUCH\ ON, & \text{if } (signal \geq Touch\ threshold + Hysteresis) \geq debounce \\ TOUCH\ OFF, & \text{if } (signal \leq Touch\ threshold - Hysteresis) \\ TOUCH\ OFF, & \text{if } (Signal \geq Touch\ threshold + Hysteresis) < debounce \end{cases}$
Number of targets ²	4	

Note: These parameters are graphically shown in [Figure 18](#).

5.4 Ensure SNR Is Greater Than or Equal to 5:1

After hardware parameters are set, you need to measure the sensor SNR and ensure that it is greater than or equal to 5:1. An SNR of 5:1 ensures robust operation under all conditions.

SNR is the ratio of the sensor signal and the peak-to-peak noise counts, as shown in Equation [10].

$$SNR = \frac{Signal}{Peak\ to\ Peak\ Noise} \quad [10]$$

Where,

Signal = Output count (Raw count) with metal target – Output count (Raw count) without metal target

Peak to Peak Noise = Peak-to-Peak raw count noise measured over 2,000 samples, as shown in [Figure 17](#).

¹ Applicable to Button and Encoder Dial widgets only.

² Applicable to Encoder Dial widget only.

Figure 17. Computing SNR

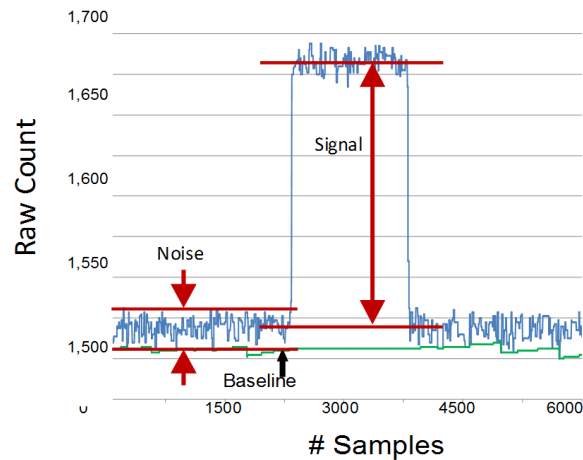

To compute the SNR, acquire a fixed number of samples, for example 2,000 raw count samples, as [Figure 17](#) shows, and measure the peak-to-peak noise count. Place your target at the required proximity-sensing distance and measure the shift in raw counts. The signal will be equal to the raw count (after placing the target) minus the average raw count (before placing the target.)

You can measure raw counts and compute the SNR using two methods:

- **MagSense Tuner:** Using the MagSense Tuner is the easiest method for computing the SNR. However, this method supports only I²C communication to read the sensor data and requires you to run a specific set of APIs in the firmware. See the MagSense Tuner section in the [PSoC 4 Inductive Sensing \(MagSense\) Component datasheet](#).
- **Bridge Control Panel (BCP):** BCP is a Cypress tool to read data from a slave device via an I²C/SPI/UART interface.

Depending on your requirements, select a suitable method for measuring the SNR and implement the firmware. [Appendix B](#) implements both methods. You can use that the appendix section as a reference and implement the method for computing the SNR.

5.5 Set Optimum Threshold Parameters

If the SNR is greater than 5:1, and the scan time and power consumption requirements are met, set the threshold parameters to the recommended values listed in [Table 6](#). See [Figure 18](#) and the [MagSense Component Widget Details Configuration](#) section.

Table 6. Sensor Threshold Parameters

Threshold Parameter	Recommended Value
Proximity threshold	80 percent of proximity signal
Touch threshold	80 percent of touch signal
Finger threshold	80 percent of touch signal
Noise threshold	40 percent of proximity signal
Negative noise threshold	40 percent of proximity signal
Hysteresis	10 percent of proximity signal
Debounce	Set this parameter to '1' if you are using the ALP filter; otherwise, set it to '3'
Low baseline reset	30

Figure 18. Thresholds

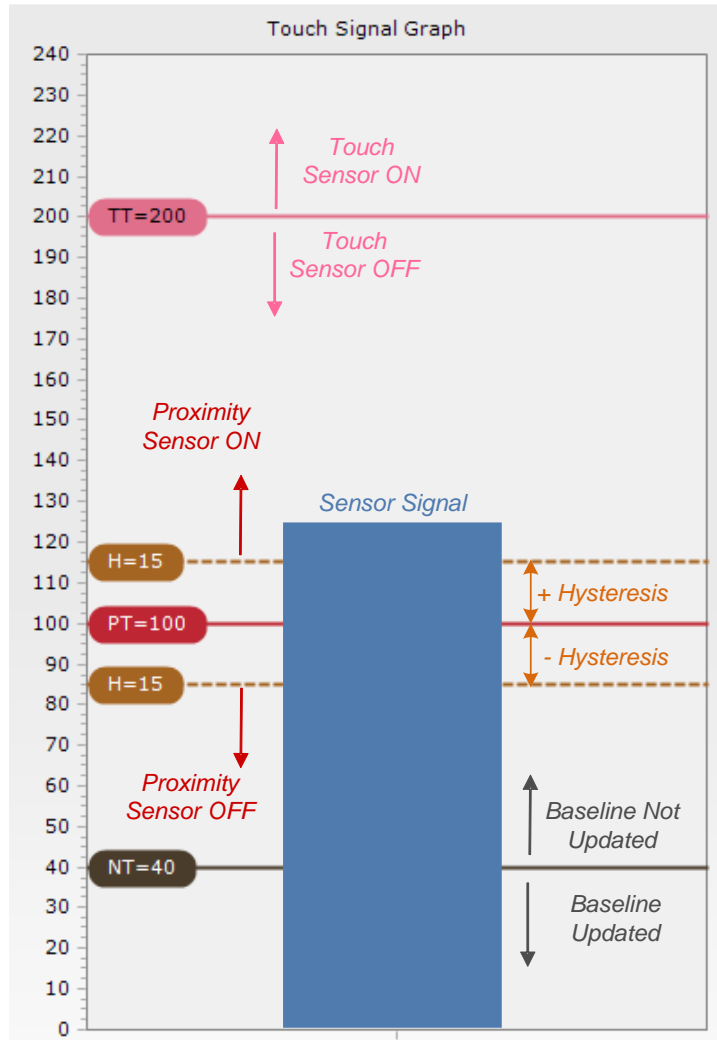

PRELIMINARY

5.6 Design Debug

If you cannot tune the design, it indicates that debugging is required. Do the following:

- **Verify Tuning:** Measure the frequency of the Lx signal using an oscilloscope to verify whether it is where you expect it to be for your LC tank.
- **Measure the AC response of the LC tank:** Measure the tank response with an oscilloscope and ensure that the sine wave amplitude at resonance is the V_{AMP} that you expect.
- **Measure the tank f_{SR} :** Measure the self-resonant frequency of the coil (after disconnecting the capacitance C) with an impedance meter and make sure that it is at least three times larger than f_0 . The phase of the inductor goes to 0° at the f_{SR} frequency.

Figure 19. Inductor Impedance Magnitude/Phase Response Over Frequency

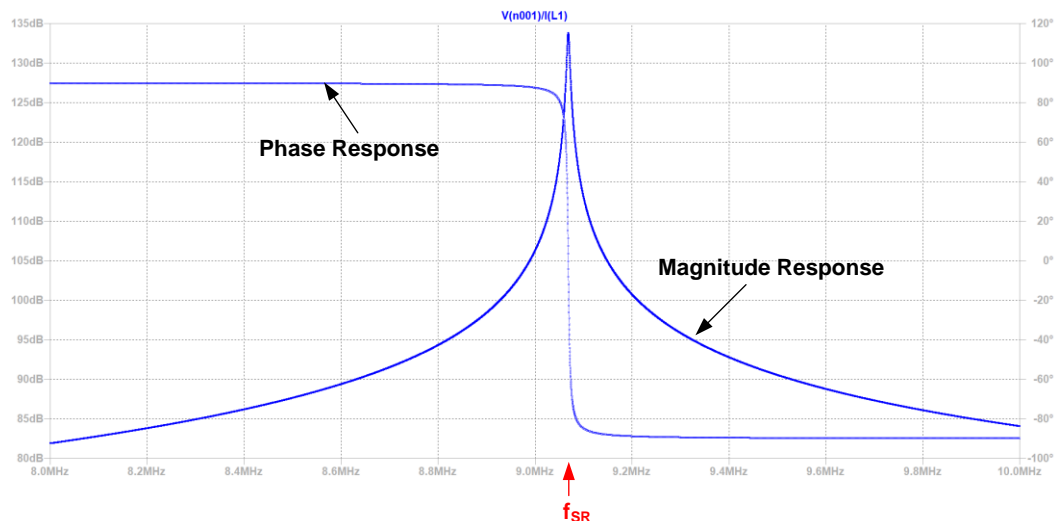

6 Additional Firmware Filters to Reduce Noise

Filters help to reduce raw count noise and improve SNR. A high SNR implies a large proximity-sensing distance. The MagSense Component supports the following types of filters: median, average, and first-order IIR (as already outlined in Table 3).

To achieve high noise attenuation and improve the response time, it is possible to use intelligent adaptive filters such as the ALP filter, as explained in the next section.

6.1 Advanced Low-Pass (ALP) Filter

The ALP filter is a combination of multiple low-pass filters specifically designed to attenuate noise in the proximity sensor raw count. Figure 20 shows the block diagram of the ALP filter. The ALP filter switches between multiple low-pass filters depending on the sensor signal and values of the threshold parameters to achieve maximum noise attenuation and provide a fast response time.

The ALP filter has a slow-response filter and a fast-response filter. The slow-response filter provides the maximum noise attenuation, but its response time is slow. On the other hand, the fast-response filter provides a fast response time but results in less noise attenuation.

Figure 20. ALP Filter Block Diagram

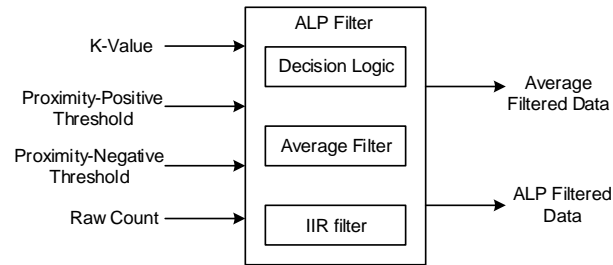

The inputs to the ALP filter are as follows:

- **Raw count:** The raw count of the sensor is the digital measurement of the LC tank amplitude.
- **K-value:** The K-value of the ALP filter determines the amount of noise attenuation in the proximity sensor raw count. The K-value can be one of the following:
 - IIR_K_16
 - IIR_K_32
 - IIR_K_64

Noise attenuation decreases in the following order:

$$\text{IIR_K_64} > \text{IIR_K_32} > \text{IIR_K_16}$$

- **Proximity-positive threshold:** This parameter determines the turn-on time of the proximity sensor when a target approaches it. When the sensor signal is greater than this value, the ALP filter switches to the fast-response filter from the slow-response filter.
- **Proximity-negative threshold:** This parameter determines the turn-off time of the proximity sensor when a target is withdrawn from it. When the sensor signal is less than this value, the ALP filter switches to the fast-response filter from the slow-response filter.

The outputs of the ALP filter are as follows:

- **Average filtered data:** Average filtered data is used to set the proximity-positive threshold and proximity-negative threshold parameters.
- **ALP filtered data:** The ALP filtered data is the final output of the filter, that is, the raw count with very low noise.

6.1.1 Adding an ALP Filter to the Project

See [CE223813 Inductive Proximity Sensing](#) to add an ALP filter to your project.

The ALP filter requires all the proximity sensors to occupy a scan order 0 through (n-1) in the MagSense Component. Here, 'n' is the total number of proximity sensors in the design. For proximity sensors to occupy the scan order from 0, place the proximity sensor widget first followed by other sensor widgets.

6.1.2 ALP Filter Tuning

The ALP filter requires you to specify the K-value, proximity-positive threshold, and proximity-negative threshold for proper operation. Follow these steps to set the ALP filter parameters.

1. Measure the peak-to-peak noise using the raw count without any nearby target object and filters.
2. Set the K-value per the mapping in [Table 7](#).

Table 7. Selecting the K-Value

Peak-to-Peak Noise	Recommended K-Value
Less than 32 counts	IIR_K_16
Greater than 32 counts and less than 64 counts	IIR_K_32
Greater than 64 counts	IIR_K_64

3. Enable the ALP filter and program the device. Measure the peak-to-peak noise in the ALP filter's average filtered data.

4. Set the proximity-positive threshold as equal to 1.5 × peak-to-peak noise of the average filtered data.
5. Set the proximity-negative threshold as equal to 0.5 × peak-to-peak noise of the average filtered data.
6. Set the proximity threshold parameter as equal to the proximity-positive threshold. After tuning the ALP filter, the proximity threshold parameter should be set to the value listed in [Table 6](#).
7. Program the device with these settings and measure the peak-to-peak noise using the raw count for 3,000 samples.
8. Place the target at the required proximity-sensing distance and measure the signal, that is, the shift in the raw count when the target approaches the sensor.
9. Compute the SNR. If the SNR is greater than 5:1, check whether the sensor turn-off time is acceptable. If the sensor turn-off time is very slow, increase the proximity-negative threshold value. The maximum limit for the proximity-negative threshold parameter is equal to the proximity-positive threshold value.
10. If the SNR is greater than 5:1 and the sensor response time meets the requirements, proceed to set the threshold parameters listed in [Table 6](#); otherwise, increase the proximity sensor size to increase the signal.

7 Other System Design Considerations

MagSense devices support proximity-sensing distances up to a distance that equals the diameter of the coil. In addition to the distance that can be sensed, there are other system design considerations:

- [Dynamic Power Consumption](#)
- [Refresh Rate](#)

7.1 Dynamic Power Consumption

The power consumed by the resonant tank is considered dynamic power consumption. The dynamic power dissipation consists of two components as given by Equation [11].

$$P_{diss_dynamic} \leq (V_{AMP}I_{TANK}) + (V_{DC}I_{DC}) \quad [11]$$

Where,

V_{AMP} = Amplitude (peak) of voltage across tank

I_{TANK} = AC Current flowing through tank

V_{DC} = DC voltage across tank

I_{DC} = DC current through flowing tank

The tank oscillation voltage amplitude (V_{AMP}) is governed by the AC impedance of the lossy tank at resonance and the DC voltage across the tank is governed by the DC resistance of the coil which can be approximated by Equation [12], where R_P is defined by Equation [3] and R_{DC} is the DC resistance of the coil.

$$V_{AMP} \approx R_P I_{TANK} \quad [12]$$

$$V_{DC} \approx R_{DC} \frac{V_{DDA}}{R_{Lx}}$$

Because V_{AMP} , R_P , V_{DDA} , R_{Lx} and R_{DC} are known, you can estimate the power consumed using Equation [13]. Considering the above parameters is important when designing your MagSense system and estimating the dynamic power consumption of the tank.

$$P_{diss_dynamic} \leq \left(\frac{V_{AMP}^2}{R_P} + R_{DC} (V_{DDA}/R_{Lx})^2 \right) \quad [13]$$

By adding a DC blocking capacitor (100 nF) to the Lx line as shown in Figure 21, the second term (DC component) in Equation [13] can be eliminated. This reduces the total power consumption of the system.

Note: C_{AC0} to C_{AC15} are DC blocking capacitors in Figure 21.

Figure 21. DC Blocking Capacitor on Lx line

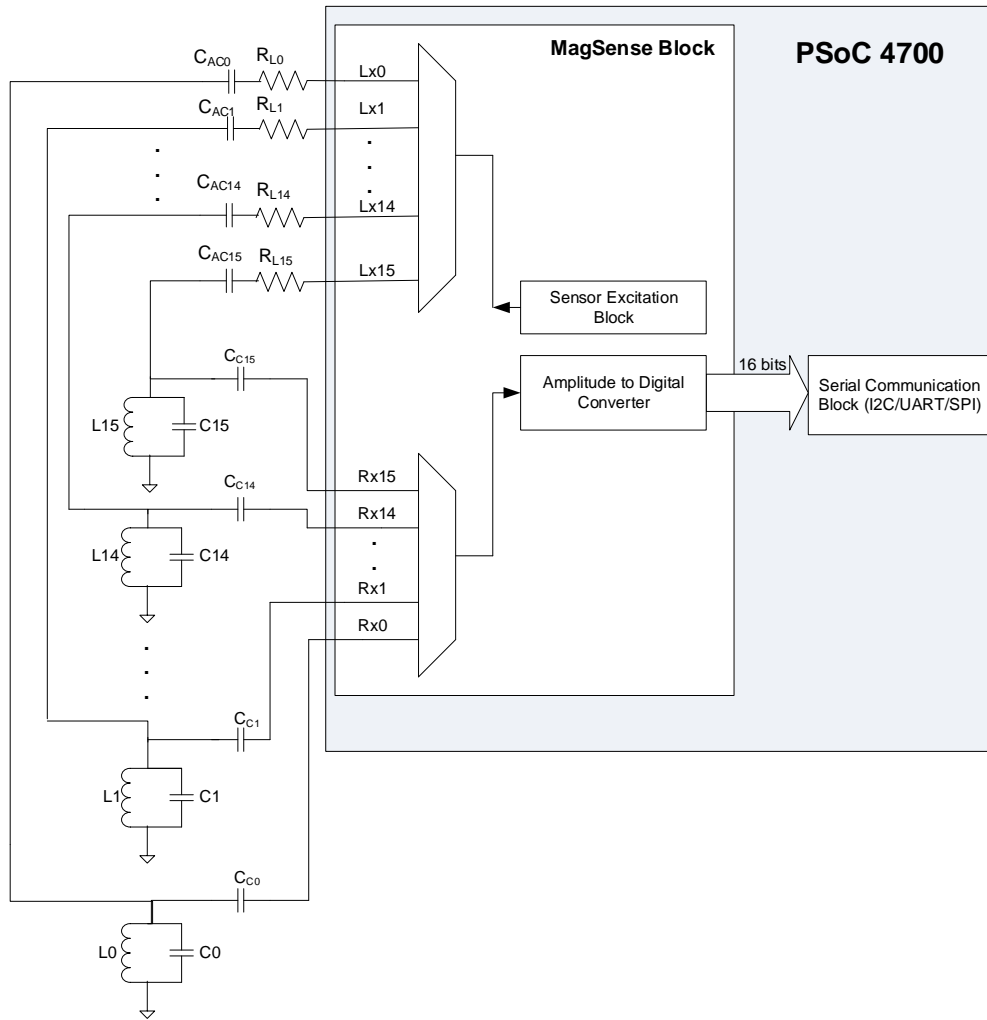

7.2 Refresh Rate

The refresh rate can be estimated using the 'Total scan time' data in the **Scan Order** tab of the Advanced Window in the MagSense Component. In the example in [Figure 22](#), four sensors are scanned, and the total scan time is 400 μ s. The refresh rate decides the response time of the sensor.

Figure 22. Scan Order Window with Scan Time Estimate

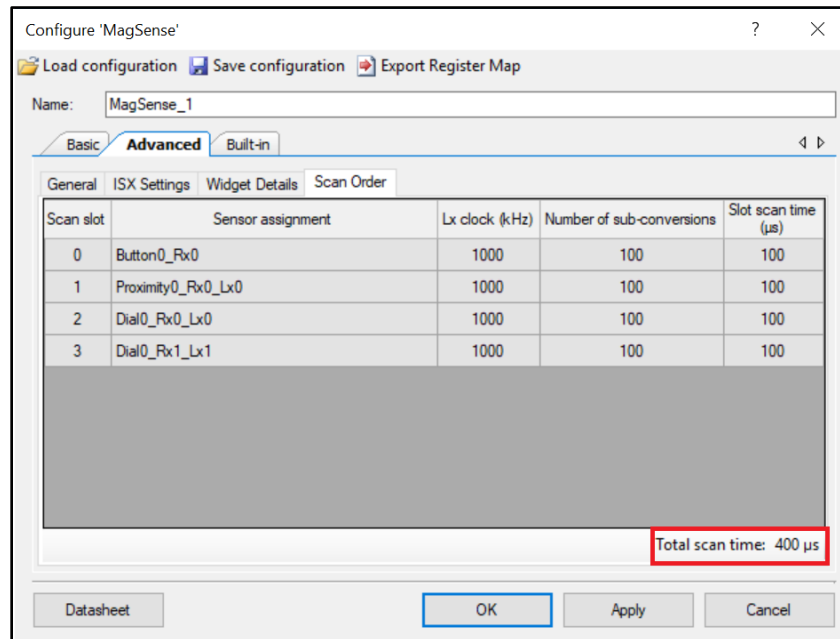

8 Related Application Notes

- [AN79953](#) – Getting Started with PSoC 4
- [AN86233](#) – PSoC 4 Low-Power Modes and Power Reduction Techniques

9 Bibliography

[Ref 1] Mohan, S. "Simple Accurate Expressions for Planar Spiral Inductances" in *IEEE Journal of Solid State Circuits*, vol. 34, no. 10, (Oct. 1999); pp 1419-1424.

[Ref 2] Howard Johnson, Martin Graham. "*High-Speed Digital Design: A Handbook of Black Magic*".

Appendix A. Sensor Design

Sensor design plays a crucial role in achieving the required inductive proximity-sensing distance.

A.1 Sensor Resonant Frequency (f_0)

The sensor requires a capacitor (C) in parallel to form a parallel resonant circuit. The inductance and capacitance of that circuit determine the resonant frequency (f_0) according to the simplified expression in Equation [14].

$$f_0 = \frac{1}{2\pi\sqrt{LC}} \quad [14]$$

The range of currently supported inductance is indicated by the graph in Figure 23, where the minimum resonant frequency of operation is 45 kHz and the maximum is 3 MHz.

Figure 23. Range of Supported Inductance and Capacitance Values

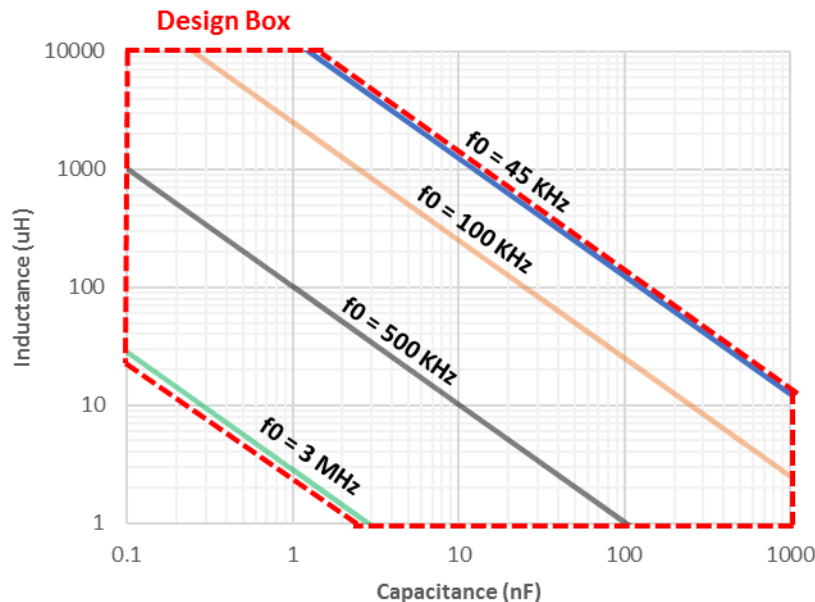

A.1.1 Capacitance Range

The supported capacitance range is 0.1 nF to 470 nF. The 0.1 nF lower limit is defined to reduce the effect of coil parasitic capacitance on the resonant frequency (f_0). The upper limit is based on the availability of NPO (also referred to as COG) grade capacitors, which are easy to obtain up to 470 nF.

A.1.2 Inductance Range

The supported inductance range is 1 μ H to 10,000 μ H. The 1 μ H lower limit is defined by practical inductance values that can operate with the Lx frequency up to 3 MHz. **Inductances > 10 μ H are preferred.**

A.2 R_P and R_S Range

When designing the inductive coil, understanding the R_P and R_S values of the coil and how they impact the design is important. The definition of each is as follows:

- R_P is the parallel AC impedance of the tank at resonant frequency.
- R_S is the series AC resistance of the sensor at resonant frequency.

Figure 24 shows the series and parallel electrical model of the tank.

Figure 24. Electrical Model of Tank Circuit

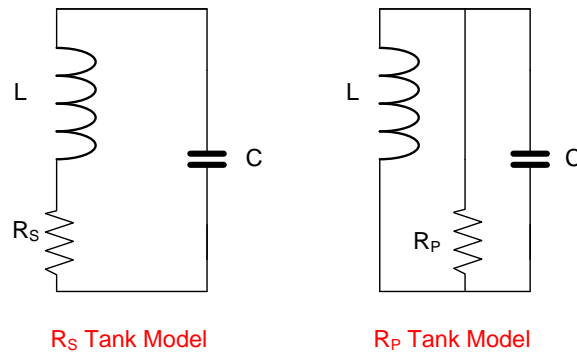

A.2.1 R_S and the Skin Effect

The series resistance of the coil is driven by the skin effect. At lower frequencies, the series resistance of the coil is dominated by ohmic resistance. According to the skin effect, the AC current flow in a conductor is the largest near the surface of the conductor and decreases toward the core. The result is that the effective resistance of the conductor increases with frequency. The skin effect depends on the resistivity of the coil material, the length, width, and trace height of the coil, and the frequency. R_S should be minimized to reduce losses in the tank.

Use the following general rules for a Parallel (“tank”) LC circuit as guidelines:

- R in series with L: Resonant frequency is shifted *down*
- R in series with C: Resonant frequency is shifted *up*

Resonant frequency change with the skin effect R_S is estimated by Equation [15].

$$f_0 = \frac{1}{2\pi} \sqrt{\frac{1}{LC} - \left(\frac{R_S}{L}\right)^2} \quad [15]$$

A.2.2 R_P

The parallel resistance of the tank can be derived from the series resistance (R_S) according to Equation [16] and Equation [3].

$$R_P = \frac{1}{R_S} (2\pi f_0 L)^2 \quad [16]$$

A.2.3 R_P and Quality Factor (Q)

The Quality factor of an LC tank is defined by Equation [17].

$$Q = \omega_0 \frac{\text{energy stored}}{\text{average power dissipated}} \quad [17]$$

For a parallel LC tank, Equation [17] can be represented in terms of coil parameters (i.e., R_P , Q, f_0 , and L). Equation [18] is the resulting expression for Q. Higher Q factor provides increased signal in the presence of metal target.

$$Q = \frac{2\pi f_0 L}{R_S} \quad [18]$$

A.2.4 R_P and R_S Range

Figure 25 plots the inductance and R_P for different resonant frequencies and different values of R_S .

The results shown in Figure 25 give an indication of the values of R_S and R_P that can be supported over the range of resonant frequencies supported by the PSoC 4700 MCU. These plots are guidelines only; in practice, there are interdependencies between parameters L , R_S , and R_P . The supported R_P range is 350 Ω to 50,000 Ω .

Figure 25. Inductance Versus R_P over f_0 and R_S

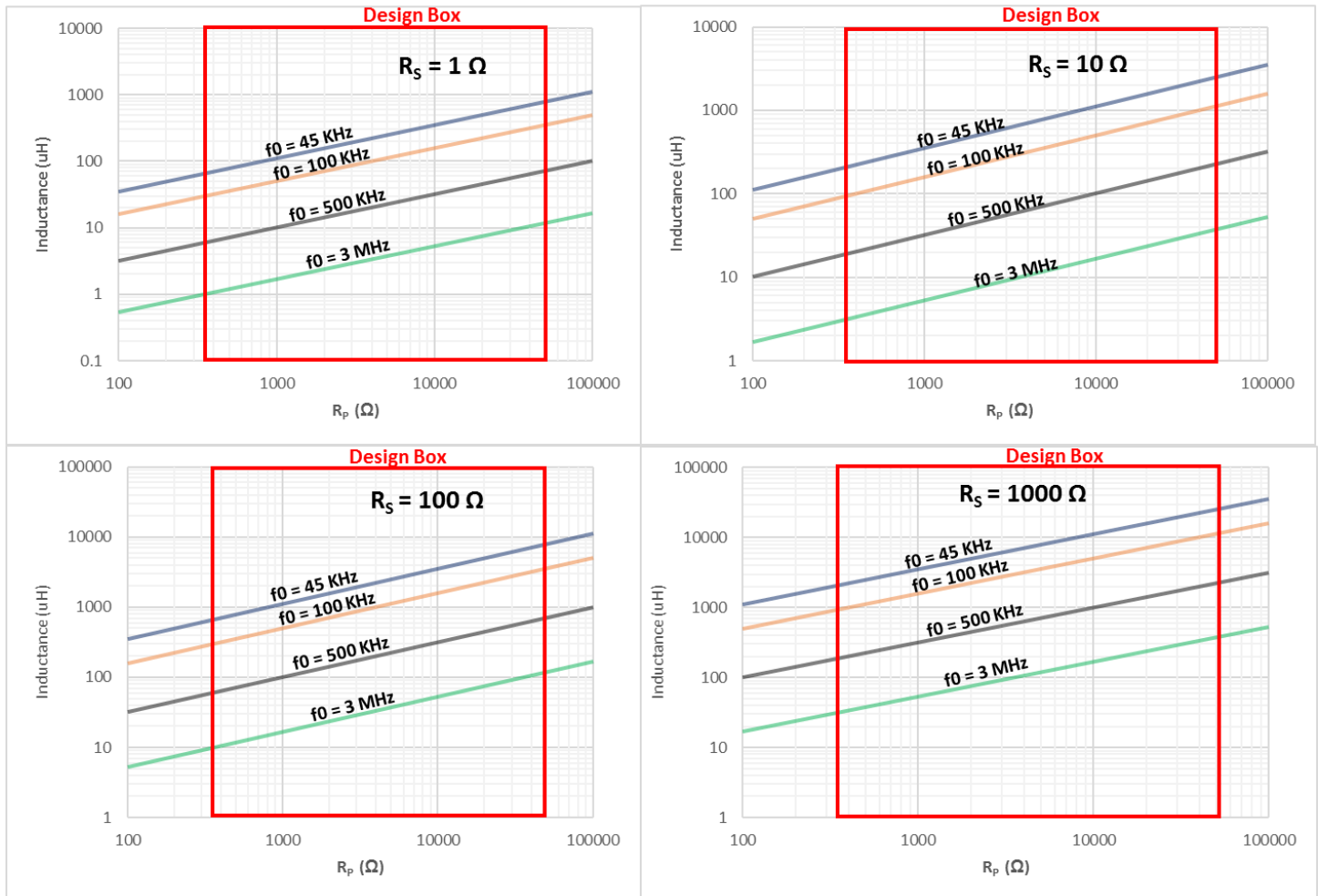

A.3 Sensor Shape

The shape of the inductive sensor is important because it determines the shape of the generated magnetic field and therefore the change in inductance in the presence of a target metal object. The following are common shapes of PCB and flex coils:

- **Circular coil:** Circular coils are generally used when sensing a target object that is moving orthogonal to the sensor plane, as Figure 26 shows. The illustration also highlights the optimal plane of movement of the target for a circular sensor.

Note: Non-circular coils have a higher R_S for the same Inductance.
- **Hexagonal coil:** Hexagonal coils are designed to approximate circular coils in cases where a circular coil is difficult to manufacture. See Figure 27 for an example of a hexagonal coil structure.
- **Square coil:** Square coil provides optimal performance with respect to sensitivity in both horizontal and vertical directions. See Figure 27 for an example.

- Rectangular coil:** Rectangular coils can be used to detect movement along a preferred axis. Figure 28 shows an example of a rectangular coil with the axis for optimal detection of movement for this coil indicated in the diagram.

Figure 26. Circular Coil with Illustration Showing Optimal Plane of Movement

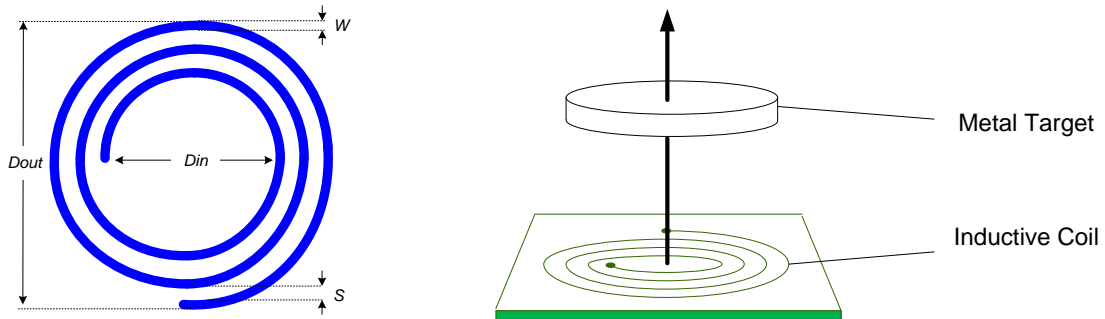

Figure 27. Hexagonal Coil and Square Coil Examples

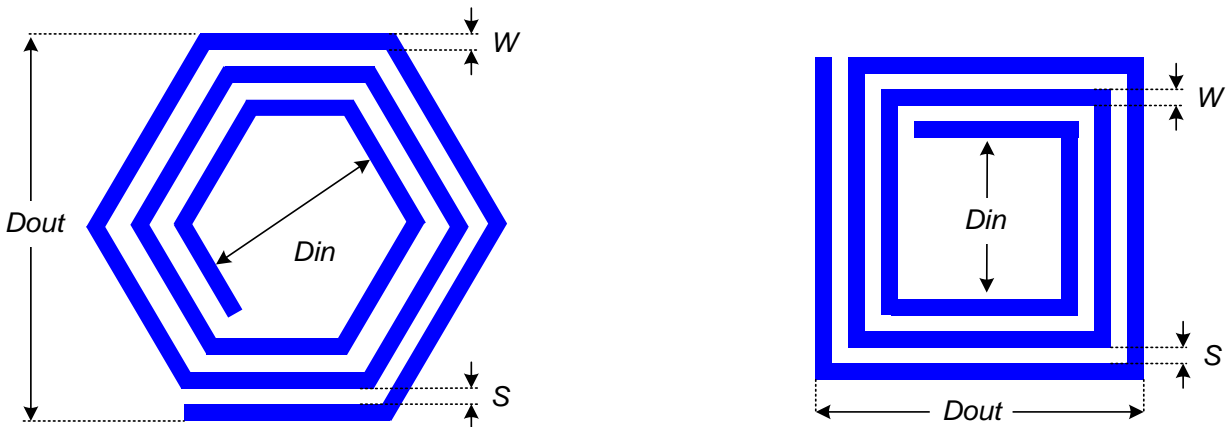
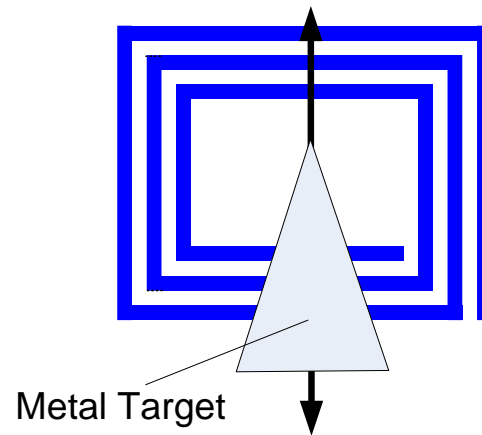

Figure 28. Rectangular with Illustration Showing Optimal Plane of Movement



A.4 Sensor Parameters

For a given shape, the sensor coil is specified by the following parameters, some of which are illustrated in [Figure 26](#), [Figure 27](#), and [Figure 28](#):

- n , the number of turns.
- w , the turn width.
- s , the turn spacing.
- D_{in} , the inner diameter.
- D_{out} , the outer diameter – usually either D_{in} or D_{out} needs to be specified; the other can be derived from other parameters

A.5 Sensor Dimensions

The extent of the magnetic field is decided by sensor physical dimensions; the outer diameter of the sensor, D_{out} , is the critical parameter. The Cypress solution aims for proximity-sensing distances up to a coil diameter from the coil while maintaining the signal-to-noise ratio (SNR) at greater than or equal to 5:1. See section 5.4 for details on signal-to-noise ratio (SNR).

If the metal target is near the coil, a small ratio of D_{in}/D_{out} is optimal for the coil to give maximum change in inductance with distance. When the metal target is further away from the coil (D_{out}), outer windings contribute most to the electromagnetic field and windings near the center can be removed. [Figure 29](#) shows the normalized change in inductance ($\Delta L/L$) as the metal target is moved away from the coil at the distances D_{out} and $D_{out}/4$ with different coil D_{in}/D_{out} ratios.

Figure 29. Normalized Inductance Change ($\Delta L/L$) Versus D_{in}/D_{out} Ratio for a 13-mm Diameter Coil

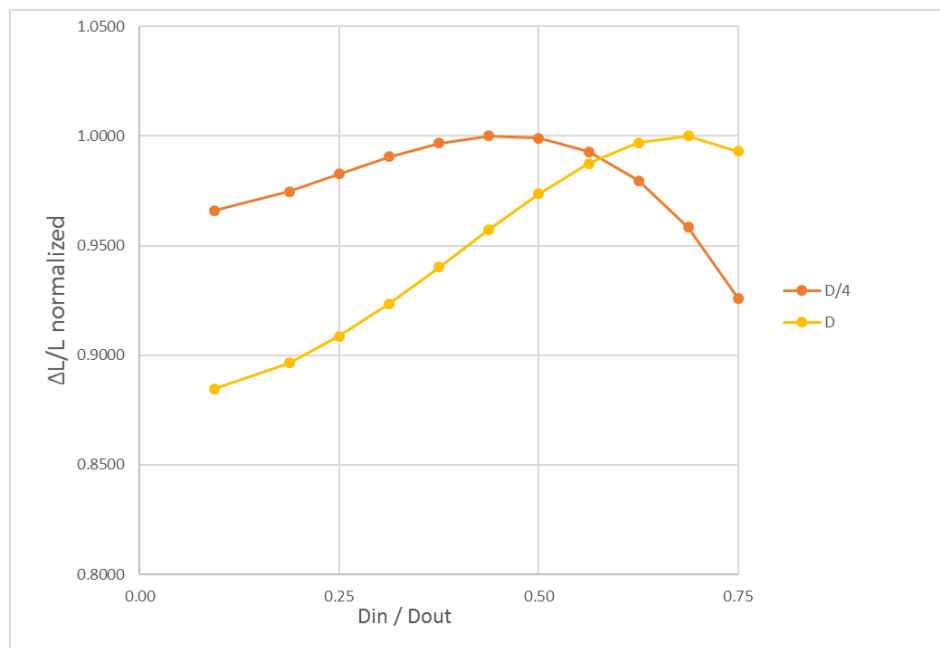

A.6 Sensor Modeling

The values L and R_s of the sensor need to be estimated for the tuning flow outlined in [Figure 4](#).

A.6.1 Sensor Design – Approximate Equations

The following equations can be used to estimate the parameters of the inductor from coil dimensions.

Note: These expressions are not as accurate as a field solver, and are used for approximations only.

The Inductance of the coil can be estimated using the expression below derived in [\[Ref 1\]](#). Equation [\[19\]](#) is based on a current sheet approximation.

$$L_{gmd} = \frac{\mu_0 n^2 D_{avg} C_1}{2} \left(\ln \left(\frac{C_2}{\rho} \right) + C_3 \rho + C_4 \rho^2 \right) \quad [19]$$

C_1, C_2, C_3, C_4 = layout constant dependant on the shape of the coil. See [Table 8](#).

$$D_{avg} = 0.5 \cdot (D_{out} + D_{in})$$

$$\rho = \text{the fill factor} = (D_{out} - D_{in}) / (D_{out} + D_{in})$$

$$\mu_0 = \text{the permeability of free space, } 4\pi \times 10^{-7}$$

$$n = \text{the number of turns}$$

Table 8. Coefficients for Current Sheet Method

Coil Shape	C_1	C_2	C_3	C_4
Square	1.27	2.07	0.18	0.13
Hexagonal	1.09	2.23	0.00	0.17
Circle	1.00	2.46	0.00	0.20

An expression to estimate the R_s of a conductor due to the skin effect has been derived in [\[Ref 2\]](#). This equation provides an estimate of the AC resistance of the inductor in ohms/inch. [Table 9](#) shows some values for ρ_R (the relative resistivity of the coil material, compared to copper). Note that the value of R_s calculated below is the unit value. To get the total value of R_s , the unit value needs to be multiplied by the length of the trace which can be measured from the PCB Design tool by making a sample coil of desired shape.

$$R_s = \frac{2.16 \times 10^{-7} \cdot \sqrt{f \rho_R}}{2(w + d)} \quad [20]$$

Where,

w = trace width, inches

d = trace height, inches

f_0 = frequency, Hz

ρ_R = relative resistivity, compared to copper = 1.00

R_s = AC resistance, ohms/inch

Table 9. Conductivity of Different Materials Compared to Copper

Metal	Resistivity ($\times 10^{-7}$ ohms inch)	Resistivity Relative to Cu
Copper	6.7879	1.000
Aluminum	10.3606	1.526
304 SS	302.847	44.616
Titanium Alloy	667.29	98.306

A.6.2 Sensor Design – 2D/3D EM Solver

An electromagnetic (EM) field solver tool such as from Comsol™ or Maxwell™ can be used to get a complete electrical model of the Inductor and understand its characteristics. Figure 30 shows an example of the coil modeling tool graphical outputs.

Figure 30. Examples of Output from an Electromagnetic Field Solver (Comsol)

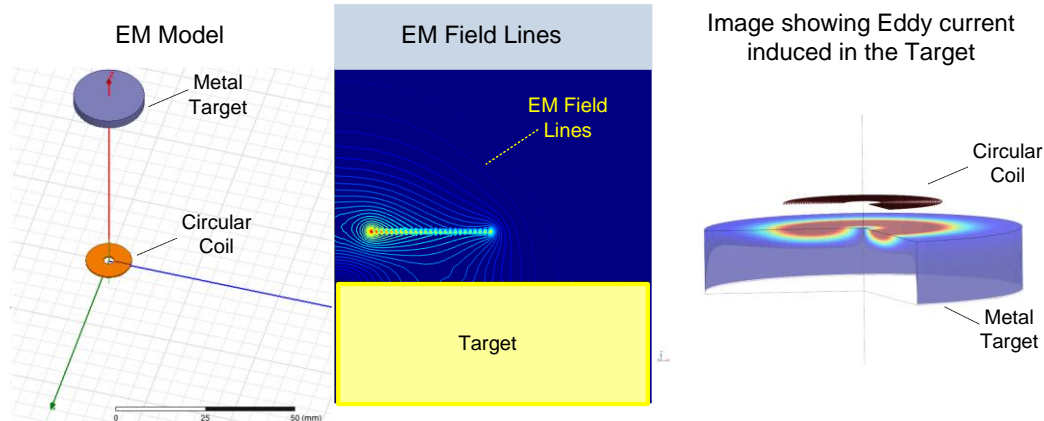

A.7 Sensors with Multiple Layers

For a given diameter of the coil, there is a maximum limit to the number of turns due to the minimum allowable space between traces. If additional inductance is needed on a PCB, a multi-layer inductor can be designed using multiple layers of the PCB. The key consideration for multi-layer inductors is that the current flow on different layers is in the same direction so that it constructively adds to the EM field and does not destructively take from it. There are two configurations shown:

- Series Inductors:** Inductors in a series configuration on multiple layers can help to achieve a larger inductance value. Figure 31 shows the electrical and layout model of this configuration. The arrows show the direction of current flow. This configuration increases the series resistance (R_S) of the overall inductor.
- Parallel Inductors:** Inductors in a parallel configuration can be used to reduce the series resistance (R_S) of the overall inductor. Figure 32 shows the electrical and layout model of this configuration. The arrows show the direction of current flow.

Figure 31. Multi-Layer Inductors in a Series Configuration

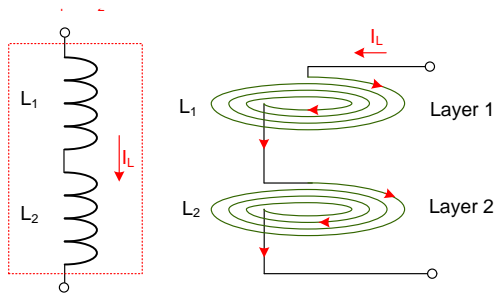
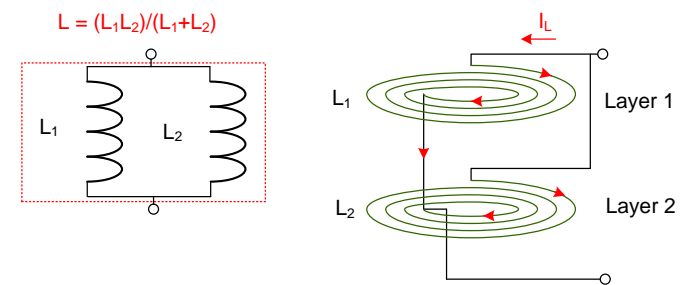

Figure 32. Multi-Layer Inductors in a Parallel Configuration



A.8 Sensor Layout Guidelines

This section highlights the layout guidelines to be considered during the physical design of an inductive sensing solution. Figure 33 provides a graphical summary of some key points.

Figure 33. Sensor Layout Considerations

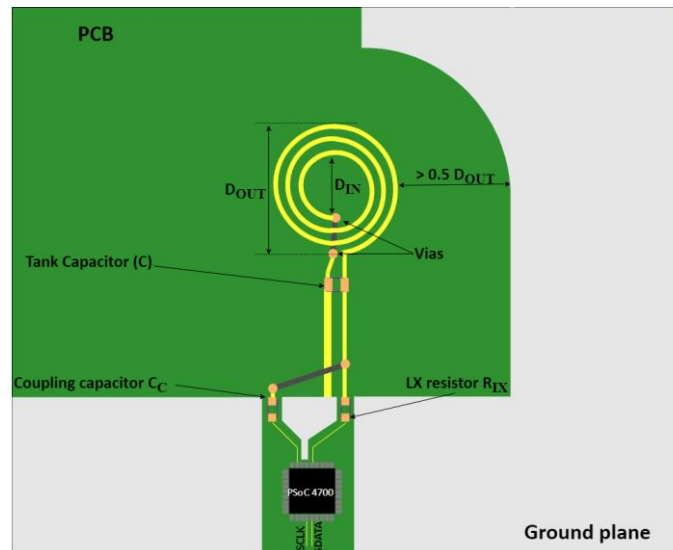

A.8.1 Tank Considerations

Consider the following while laying out the LC tank:

- Metal (routing, ground shields, and so on) should be kept away from the sensor as much as possible to maximize the signal from the sensor. If shielding is required behind the sensor, use a hatched ground and place the hatch on the bottom most PCB layer. You may have to increase the sensor diameter to compensate for some loss in signal.
- Place the metal traces $0.5 \cdot D_{OUT}$ away from the sensor where possible.
- Make sure that the ratio between the inner and outer diameter of the coil is > 0.3 . ($D_{IN}/D_{OUT} > 0.3$)
- Make sure that the via size meets the recommended size of 15 mil.
- Place the vias close to the traces.
- Maximize the number of PCB layers used for the sensor to maximize the signal.

A.8.2 External Components

Consider the following while placing external components:

- Place the coupling capacitor (C_C) and the Lx resistor (R_{Lx}) as close as possible to the PSoC.
- Minimize the C_C trace width and length between the capacitor and the PSoC. This is a sensitive node and should not have interferers running beside it. Shield this trace from any Lx traces or sources of high frequency switching noise. If shielding is not possible, use the 3W rule which states that “to reduce cross talk from adjacent traces, a minimum spacing of two trace widths should be maintained from edge to edge” as shown in Figure 34.

Figure 34. 3W Trace Spacing to Minimize Cross Talk

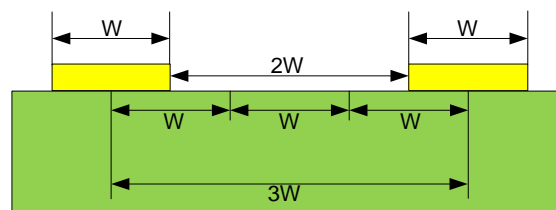

- Place the tank capacitor (C) as close to the coil as possible.
- Place the decoupling and C_{MOD} capacitors as close as possible to the chip to keep the ground impedance and supply trace impedance as low as possible. It is important that the C_{MOD} capacitors and the chip ground have low ohmic connections.
- Place the components on the underside of the PCB to ensure the Z height does not infringe upon placement of a metal over touch overlay or proximity overlay.

A.8.3 Routing Considerations

Consider the following while routing signals:

- Place the Lx and Rx lines parallel to each other.
- Make sure that the Rx lines are not near any digital toggling line.
- Make sure that the Rx lines do not use the communications line port, for instance, the I²C or SWD ports as they may interfere with the signal.

A.8.4 Power and Ground

- Use both 1 μ F and 0.1 μ F decoupling capacitors on VDDD to VSS for PSoC 4700.
- Use both 10 μ F and 0.1 μ F decoupling capacitors on VDDA to VSSA for PSoC 4700 in mains-powered applications and use 1 μ F and 0.1 μ F decoupling capacitors on VDDA to VSSA for battery-powered applications.
- Use a 1 μ F capacitor on VCCD to VSSD for the PSoC 4700.
- VDDIO noise couples with the LC tank through the IO, which resonates the tank. If supply noise is excessive in the system, consider a regulator or a filter on the VDDD supply.
- Make sure to use a low resistance ground plane to prevent any ground noise coupling into the LC tank.

A.9 Hardware Considerations

A.9.1 Ground Plane

A ground plane on the PCB reduces both RF emissions and interference. Solid grounds near MagSense sensors reduce the inductance. It is recommended to use hatched ground planes surrounding the sensor observing the distances outlined in section A.8.

A.9.2 Series Resistors on Digital Communications Lines

Communication lines, such as I²C and SPI, can have long traces that act as antennae. They benefit from the addition of series resistance; 330 Ω is the recommended value as shown in Figure 35. The recommended pull-up resistor value for I²C communication lines is 4.7 k Ω . If a series resistor of value greater than 330 Ω is placed in series with these lines, the V_{IL} and V_{IH} voltage levels may fall out of specifications, while 330 Ω will not affect I²C operation as the V_{IL} level remains within the I²C specification limit of 0.3 VDD when PSoC outputs a LOW.

Figure 35. Series Resistors on Communication Lines

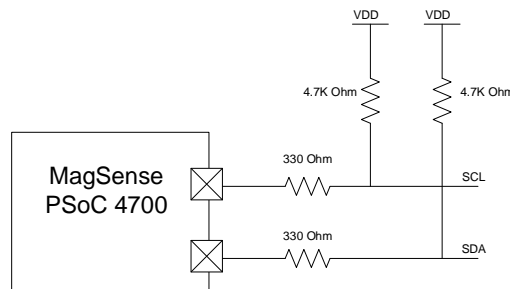

A.9.3 Trace length

Long traces can pick up more noise than short traces. Long traces also add to C_P. Minimize the trace length whenever possible.

A.9.4 Current Loops

Another important layout consideration is to minimize the return path for currents. This is important as the current flows in loops. Unless there is a proper return path for high-speed signals, the return current will flow through a longer return path forming a larger loop, thus leading to increased emissions and interference.

If you isolate any MagSense ground hatch and ground fill around the device the sensor-switching current may take a longer return path. The MagSense sensors are switched at a high frequency, so the long return current may cause EMC issues. It is recommended to use a single ground fill to minimize the length of such a return path and any subsequent emissions.

A.10 Sensor Design Spreadsheet

A Microsoft spreadsheet, *MagSense Toolkit.xlsx*, has been defined to assist with Inductive sensor design and is attached with this design guide. The spreadsheet has the following tabs:

- [Tuning Calculator](#)
- [Simple Coil Designer](#)
- [Metal Deflection Estimator](#)

A.10.1 Tuning Calculator

Figure 36 shows the **Tuning Calculator** tab. Using this tab, you can quickly estimate the tuning parameters for the PSoC 4700 family.

Figure 36. Simple Tuning Calculator Tab

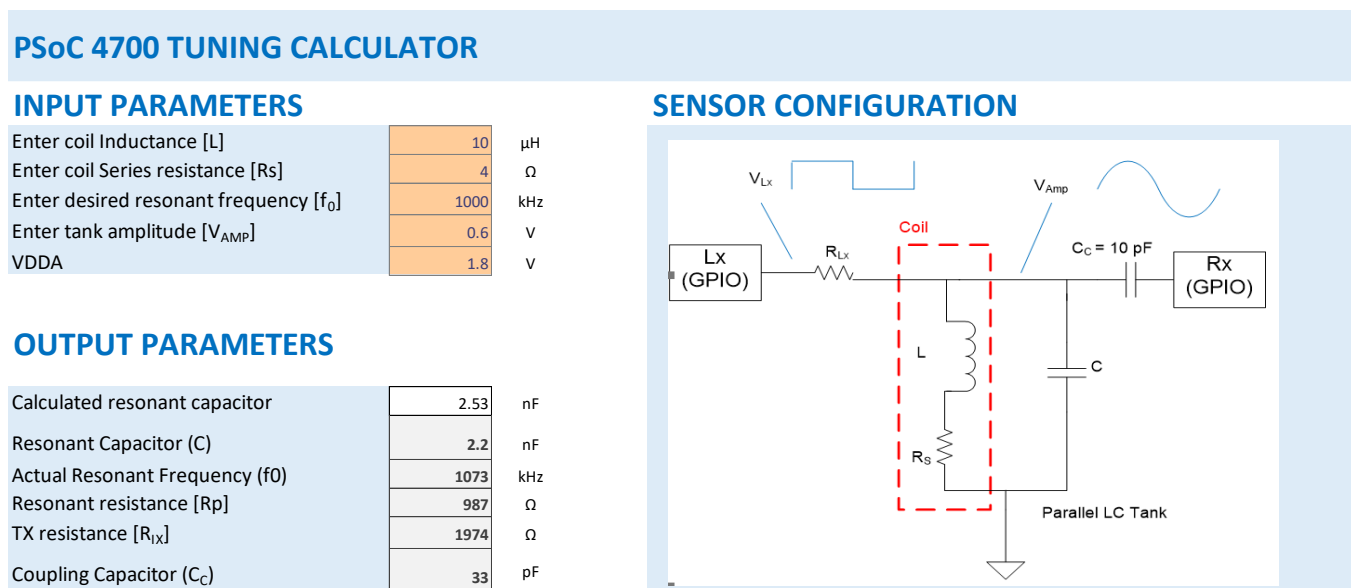

A.10.2 Simple Coil Designer

The coil designer is a tool used to design the sensor itself. A list of input parameters is shown in Figure 37. In metal proximity applications, the Target distance column can be used, which estimates the signal change with an Aluminum target at different distances from the coil. The signal change estimator is accurate to within a few percent in the proximity range from 0.1xDout to 1xDout. The output parameters are outlined in Figure 38.

Figure 37. Coil Designer Spreadsheet Input Parameters

Input Parameters											
Use Case	No. Turns	Turn space	Turn Width	Outer Diameter	Target distance	Copper Thickness	PCB Thickness Layers 1-2	PCB Thickness Layers 2-3	PCB Thickness Layers 3-4	# Layers (1-4)	Freq (f ₀)
	#	s (μm)	w (μm)	dout (μm)	mm	t (μm)	T12 (mm)	T23 (mm)	T34 (mm)	#	Hz
1	23	101.6	101.6	12200	1.00	17.37	0.762	0.762	0.203	2	1.00E+06
2	23	101.6	101.6	12200	2.00	17.37	0.762	0.762	0.203	2	1.00E+06
3	23	101.6	101.6	12200	3.00	17.37	0.762	0.762	0.203	2	1.00E+06
4	23	101.6	101.6	12200	4.00	17.37	0.762	0.762	0.203	2	1.00E+06
5	23	101.6	101.6	12200	5.00	17.37	0.762	0.762	0.203	2	1.00E+06
6	23	101.6	101.6	12200	6.00	17.37	0.762	0.762	0.203	2	1.00E+06
7	23	101.6	101.6	12200	7.00	17.37	0.762	0.762	0.203	2	1.00E+06
8	23	101.6	101.6	12200	8.00	17.37	0.762	0.762	0.203	2	1.00E+06
9	23	101.6	101.6	12200	9.00	17.37	0.762	0.762	0.203	2	1.00E+06
10	23	101.6	101.6	12200	10.00	17.37	0.762	0.762	0.203	2	1.00E+06
11	23	101.6	101.6	12200	11.00	17.37	0.762	0.762	0.203	2	1.00E+06
12	23	101.6	101.6	12200	12.00	17.37	0.762	0.762	0.203	2	1.00E+06

Figure 38. Coil Designer Spreadsheet Output Parameters

Output Parameters								Proximity Sensing Calculations		
Inductance	Ideal Tank Capacitance	Rdc	Skin Depth	Rs AC	Din/Dout	Q	Rp	Target distance	New Inductance	New Rp
μH	pF	Ohm	mm	Ohm	#	#	Ohm	mm	uH	Ohm
12.395	2043.59	10.70	0.0652	12.188	0.250	6.39	498	1.000	8.084	212
12.395	2043.59	10.70	0.0652	12.188	0.250	6.39	498	2.000	10.241	340
12.395	2043.59	10.70	0.0652	12.188	0.250	6.39	498	3.000	11.228	408
12.395	2043.59	10.70	0.0652	12.188	0.250	6.39	498	4.000	11.705	444
12.395	2043.59	10.70	0.0652	12.188	0.250	6.39	498	5.000	11.981	465
12.395	2043.59	10.70	0.0652	12.188	0.250	6.39	498	6.000	12.163	479
12.395	2043.59	10.70	0.0652	12.188	0.250	6.39	498	7.000	12.271	488
12.395	2043.59	10.70	0.0652	12.188	0.250	6.39	498	8.000	12.314	491
12.395	2043.59	10.70	0.0652	12.188	0.250	6.39	498	9.000	12.322	492
12.395	2043.59	10.70	0.0652	12.188	0.250	6.39	498	10.000	12.342	493
12.395	2043.59	10.70	0.0652	12.188	0.250	6.39	498	11.000	12.397	498
12.395	2043.59	10.70	0.0652	12.188	0.250	6.39	498	12.000	12.404	498

Table 10 shows the comparison between the L and R_S values calculated by the toolkit and the measured values for few test coils.

Table 10. Comparison of Measured and Calculated L and R_S

Coil Parameters											Measured Values		Calculated using Cypress MagSense Calculator		% Inductance Error	% R _S Error
Use Case	No. Turns	Turn space	Turn Width	Outer Diameter	Copper Thickness	PCB Thickness Layers 1-2	PCB Thickness Layers 2-3	PCB Thickness Layers 3-4	No. Layers	Frequency	Inductance	Rs	Inductance	Rs		
	#	s (mil)	w (mil)	dout (mm)	t (μm)	T12 (mm)	T23 (mm)	T34 (mm)	#	f ₀ (kHz)	L (μH)	Ohm	L (μH)	Ohm		
Coil A	40	4	4	20	17.37	1.59	n/a	n/a	2	550	55.9	20	49.5	32	11.4	60
Coil B	24	4	4	13	17.37	0.2	1.15	0.2	4	550	55.6	18	52.6	26.5	5.4	47.2
Coil C	30	6	8	29	17.37	0.2	1.15	0.2	4	1000	274	50.4	186.2	38.5	32	23.6
Coil D	16	4	4	10	17.37	1.55	n/a	n/a	2	1000	20.6	10	5.7	7.6	72.3	24
Coil E	25	4	4	13	17.37	1.59	n/a	n/a	2	1000	14.1	7.3	13.7	13.9	2.8	90.4

A.10.3 Metal Deflection Estimator

In MoT applications, it is important to understand the required area and thickness of metal plate. The metal deflection estimator uses thin plate mechanics calculations to estimate the deflection of either a rectangular or circular metal plate. An example is shown in [Figure 39](#).

Figure 39. Metal Deflection Estimator Spreadsheet

Metal Deflection Estimator		CYPRESS CONFIDENTIAL								
a/b		1	1.2	1.4	1.6	3				
alpha (Rectangle)	Simply	0.0444	0.0616	0.077	0.0906	0.1421				
	Fixed	0.0138	0.0188	0.0226	0.0251	0.0284				
alpha (Circle)	Simply	0.1267	0.1487	0.1621	0.1715	0.1851				
	Fixed	0.0611	0.0706	0.0754	0.0777	0.0791				
Shape	Rectangle	Material		Al (AL6063)						
Support Type	Simply	Material		A36 Steel						
Load Type	Uniform	Material		Stainless Steel (SS304)						
					Simply Uniform	Fixed Uniform	Simply Concentrated	Fixed Concentrated		
Use Case	a [mm] Length	b [mm] Width	h [mm] Thickness	Material (Steel/Al)	Plate (Circle/Rectangle)	F [N] Force	Rectangle W ₀ (μm)	Rectangle W ₀ (μm)	Rectangle W ₀ (μm)	Rectangle W ₀ (μm)
Example 1	10	10	0.3	Al	Rectangle	1	2.383	0.740740741	6.80085883	3.279656468
	10	10	0.3	Al	Rectangle	1.5	3.575	1.111111111	10.20128824	4.919484702
	10	10	0.3	Al	Rectangle	2	4.767	1.481481481	13.60171766	6.559312936
	10	10	0.3	Al	Rectangle	2.5	5.958	1.851851852	17.00214707	8.19914117
	10	10	0.3	Al	Rectangle	3	7.150	2.222222222	20.40257649	9.838969404
	10	10	0.3	Al	Rectangle	3.5	8.341	2.592592593	23.8030059	11.47879764
	10	10	0.3	Al	Rectangle	4	9.533	2.962962963	27.20343532	13.11862587
	10	10	0.3	Al	Rectangle	4.5	10.725	3.333333333	30.60386473	14.75845411
	10	10	0.3	Al	Rectangle	5	11.916	3.703703704	34.00429415	16.39828234
	10	10	0.3	Al	Rectangle	5.5	13.108	4.074074074	37.40472356	18.03811057

Appendix B. Reading Sensor Debug Data in Bridge Control Panel

To tune the MagSense CSD parameters for a sensor, you need to view the sensor data such as the raw count, baseline, and difference count. For viewing the sensor data, you can use the MagSense Tuner available in the MagSense Component or use the [Bridge Control Panel \(BCP\)](#) tool.

Using the BCP tool, you can view other parameters in addition to the raw count, baseline, and difference count. The MagSense Tuner requires I²C communication for viewing the sensor data, whereas the BCP tool supports both I²C and UART communication for viewing the sensor data.

This appendix explains how to view the sensor data in the BCP tool through UART communication.

[Table 11](#) lists the general structure of a UART TX packet sent to the BCP tool. The TX packet consists of a header (2 bytes), data (of variable length), and a tail (3 bytes).

Table 11. UART TX Data Packet Structure

Header		Data	Tail		
0x0D	0x0A	Variable-length data	0x00	0xFF	0xFF

Note: To learn about the exact data for any example project, see the *.iic* file provided with it.

Follow these steps to set up the BCP tool for viewing the data:

1. Connect CY8CKIT-148 to the PC using the USB cable (USB A to mini-B).
2. Press **Ctrl + F5** to program the CY8CKIT-148 kit.
3. Open the BCP tool (choose **Start > All Programs > Cypress > Bridge Control Panel <version> > Bridge Control Panel <version>**).
4. In the BCP tool, select the CY8CKIT-148 kit UART-bridge COM port in the Connected I²C /SPI/RX8 Ports window and set **RX8 (UART)** as its protocol, as [Figure 40](#) shows. The CY8CKIT-148 kit UART-bridge COM port will be listed in the Device Manager, as [Figure 41](#) shows.

Figure 40. Bridge Control Panel – COM Port and Protocol Selection

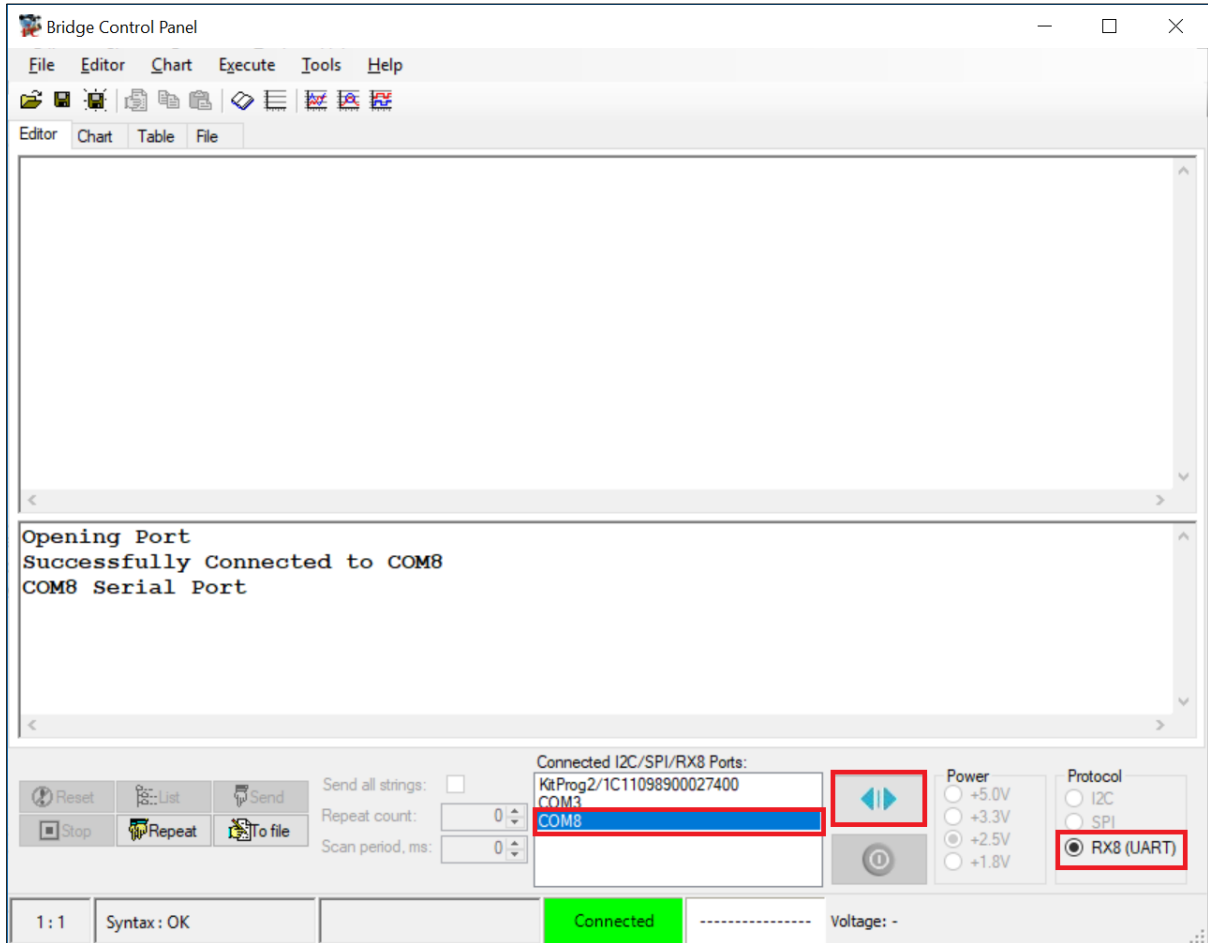
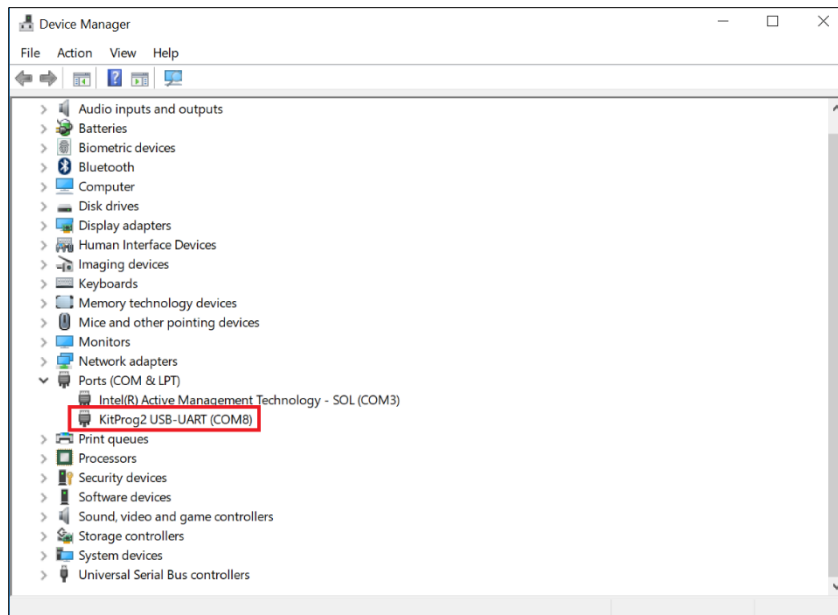
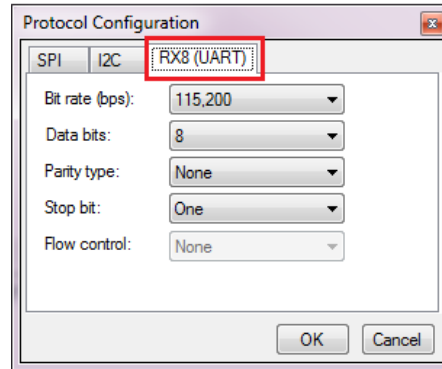

Figure 41. KitProg COM Port in Device Manager



5. Choose **Tools > Protocol Configuration** or press **F7** and configure the RX8 protocol parameters, as [Figure 42](#) shows.

Figure 42. RX8 Protocol Configuration



6. Choose **Chart > Variable Settings > Load** and navigate to the example project directory. Select the `<Project_Name>.ini` file and click **Open**. Click **OK** to apply the settings and close the window, as shown in [Figure 43](#).

Figure 43. Bridge Control Panel – Variable Settings

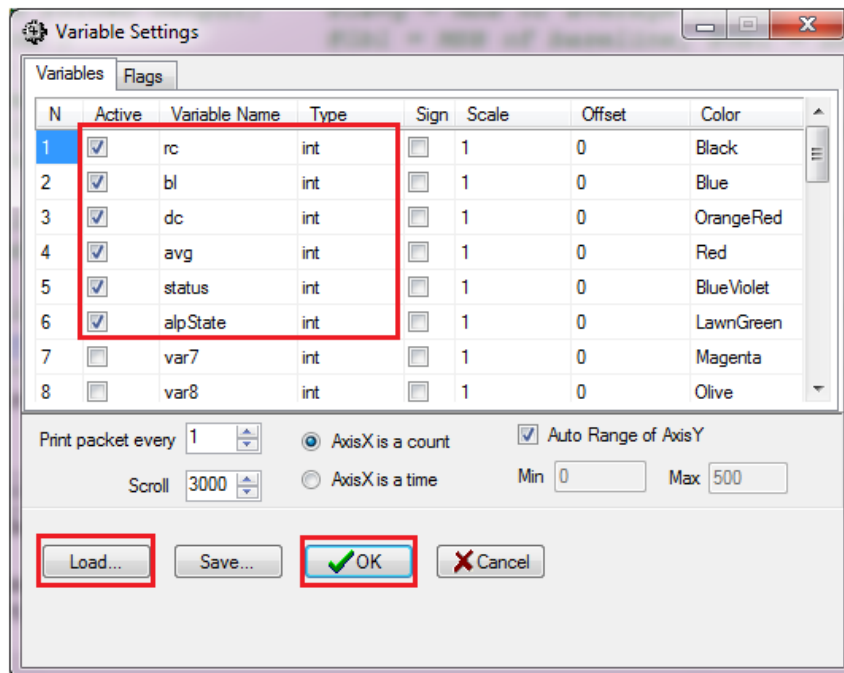

7. Choose **File > Open File** and select the `<Project_Name>.iic` file provided with the project and click **Open**.
8. Place the cursor on the command line and then click **Repeat**, as [Figure 44](#), shows to start receiving the packets.
9. To view the sensor data in a graphical format, click the **Chart** tab. Uncheck the **Select All** option and check the **rc** and **bl** options to view the raw count and baseline, as shown in [Figure 45](#). Similarly, you can view the difference count (**dc**) and the average filtered data.

Figure 44. Reading Debug Data in Bridge Control Panel

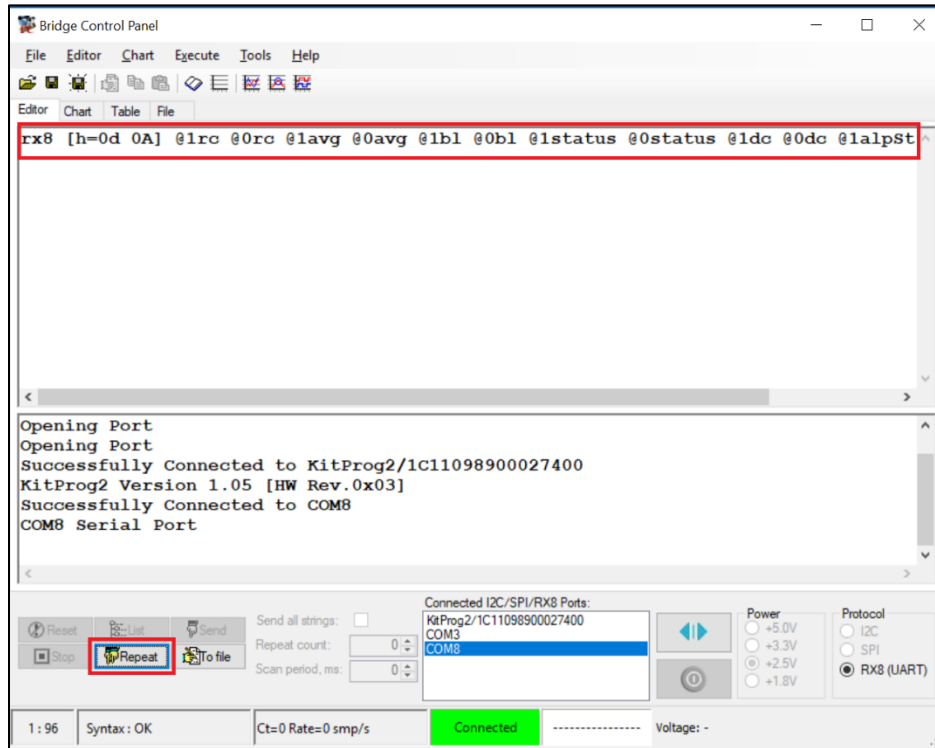
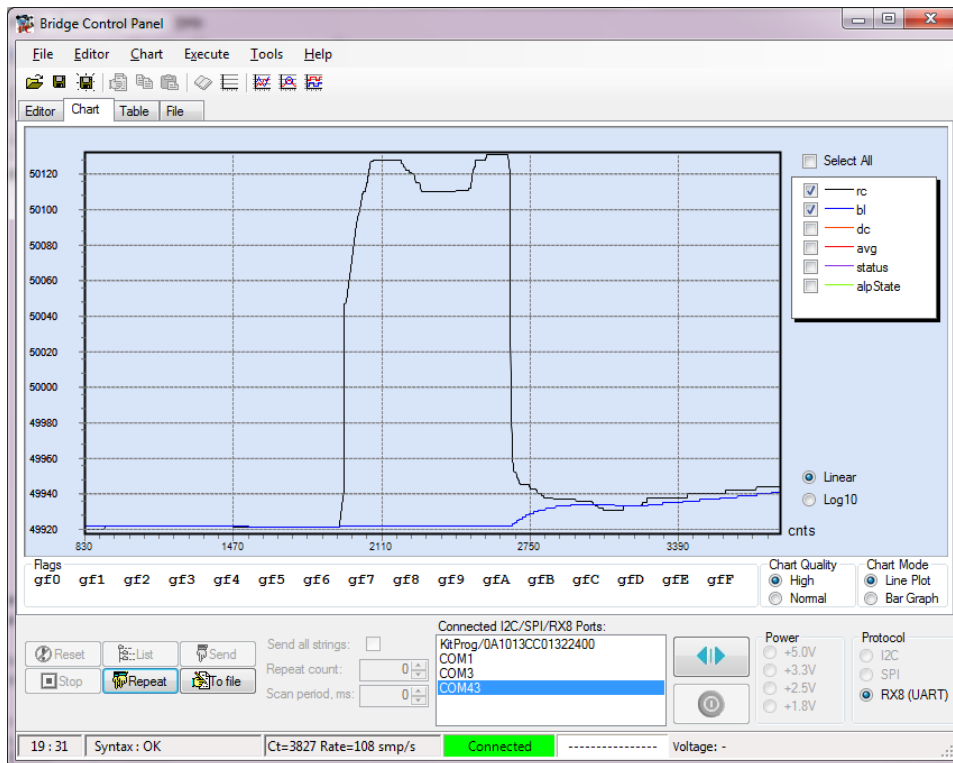

Figure 45. Viewing MagSense Debug Data in Graphical Format in Bridge Control Panel



Document History

Document Title: AN219207 - Inductive Sensing Design Guide

Document Number: 002-19207

Revision	ECN	Orig. of Change	Submission Date	Description of Change
**	6001001	PMW, DIMA	12/21/2017	New Draft Application Note for Inductive Sensing
*A	6212551	DIMA	06/20/2018	Added MoT and Rotary Encoder use cases Added DC blocking capacitor for power optimization Updated Component captures Updated Figure 2 and Figure 19 Added Sensor Design Toolkit and Layout guidelines
*B	6288116	DIMA	09/05/2018	Updated figures 12, 13, 14, 15, and 22.

Worldwide Sales and Design Support

Cypress maintains a worldwide network of offices, solution centers, manufacturer's representatives, and distributors. To find the office closest to you, visit us at [Cypress Locations](#).

Products

Arm® Cortex® Microcontrollers	cypress.com/arm
Automotive	cypress.com/automotive
Clocks & Buffers	cypress.com/clocks
Interface	cypress.com/interface
Internet of Things	cypress.com/iot
Memory	cypress.com/memory
Microcontrollers	cypress.com/mcu
PSoC	cypress.com/psoc
Power Management ICs	cypress.com/pmic
Touch Sensing	cypress.com/touch
USB Controllers	cypress.com/usb
Wireless Connectivity	cypress.com/wireless

PSoC® Solutions

[PSoC 1](#) | [PSoC 3](#) | [PSoC 4](#) | [PSoC 5LP](#) | [PSoC 6 MCU](#)

Cypress Developer Community

[Community](#) | [Projects](#) | [Videos](#) | [Blogs](#) | [Training](#)
| [Components](#)

Technical Support

cypress.com/support

All other trademarks or registered trademarks referenced herein are the property of their respective owners.



Cypress Semiconductor
198 Champion Court
San Jose, CA 95134-1709

© Cypress Semiconductor Corporation, 2017-2018. This document is the property of Cypress Semiconductor Corporation and its subsidiaries, including Spansion LLC ("Cypress"). This document, including any software or firmware included or referenced in this document ("Software"), is owned by Cypress under the intellectual property laws and treaties of the United States and other countries worldwide. Cypress reserves all rights under such laws and treaties and does not, except as specifically stated in this paragraph, grant any license under its patents, copyrights, trademarks, or other intellectual property rights. If the Software is not accompanied by a license agreement and you do not otherwise have a written agreement with Cypress governing the use of the Software, then Cypress hereby grants you a personal, non-exclusive, nontransferable license (without the right to sublicense) (1) under its copyright rights in the Software (a) for Software provided in source code form, to modify and reproduce the Software solely for use with Cypress hardware products, only internally within your organization, and (b) to distribute the Software in binary code form externally to end users (either directly or indirectly through resellers and distributors), solely for use on Cypress hardware product units, and (2) under those claims of Cypress's patents that are infringed by the Software (as provided by Cypress, unmodified) to make, use, distribute, and import the Software solely for use with Cypress hardware products. Any other use, reproduction, modification, translation, or compilation of the Software is prohibited.

TO THE EXTENT PERMITTED BY APPLICABLE LAW, CYPRESS MAKES NO WARRANTY OF ANY KIND, EXPRESS OR IMPLIED, WITH REGARD TO THIS DOCUMENT OR ANY SOFTWARE OR ACCOMPANYING HARDWARE, INCLUDING, BUT NOT LIMITED TO, THE IMPLIED WARRANTIES OF MERCHANTABILITY AND FITNESS FOR A PARTICULAR PURPOSE. No computing device can be absolutely secure. Therefore, despite security measures implemented in Cypress hardware or software products, Cypress does not assume any liability arising out of any security breach, such as unauthorized access to or use of a Cypress product. In addition, the products described in these materials may contain design defects or errors known as errata which may cause the product to deviate from published specifications. To the extent permitted by applicable law, Cypress reserves the right to make changes to this document without further notice. Cypress does not assume any liability arising out of the application or use of any product or circuit described in this document. Any information provided in this document, including any sample design information or programming code, is provided only for reference purposes. It is the responsibility of the user of this document to properly design, program, and test the functionality and safety of any application made of this information and any resulting product. Cypress products are not designed, intended, or authorized for use as critical components in systems designed or intended for the operation of weapons, weapons systems, nuclear installations, life-support devices or systems, other medical devices or systems (including resuscitation equipment and surgical implants), pollution control or hazardous substances management, or other uses where the failure of the device or system could cause personal injury, death, or property damage ("Unintended Uses"). A critical component is any component of a device or system whose failure to perform can be reasonably expected to cause the failure of the device or system, or to affect its safety or effectiveness. Cypress is not liable, in whole or in part, and you shall and hereby do release Cypress from any claim, damage, or other liability arising from or related to all Unintended Uses of Cypress products. You shall indemnify and hold Cypress harmless from and against all claims, costs, damages, and other liabilities, including claims for personal injury or death, arising from or related to any Unintended Uses of Cypress products.

Cypress, the Cypress logo, Spansion, the Spansion logo, and combinations thereof, WICED, PSoC, CapSense, EZ-USB, F-RAM, and Traveo are trademarks or registered trademarks of Cypress in the United States and other countries. For a more complete list of Cypress trademarks, visit cypress.com. Other names and brands may be claimed as property of their respective owners.