

**REVISION AN**

**DO NOT SCALE FROM THIS PRINT**

- NOTES:**
- ⊕ REPRESENTS A CRITICAL DIMENSION.
  - BURR ALLOWANCE: .003[0.08] MAX.
  - PARTS TO BE MOLDED TO POSITION.
  - MINIMUM PULLOUT FORCE: 5 lbs [22.24 N].
  - CONTACT MUST BE INSERTED UNTIL RETENTION FEATURE LOCKS INTO PLACE.
  - ⊕ ALL FINISHED GOODS ARE TO BE ELECTRICAL TESTED INCLUDING HI-POT TEST @ 1000 VOLTS DC. AFTER FINAL ELECTRICAL TEST, MARK EACH ASSEMBLY PER INSTRUCTIONS REFERENCED IN CO-(AD-ID)-WI-3092-M.
  - TINNED COPPER WIRE IS ROHS COMPLIANT.
  - FOLLOW PACKAGING MANUAL INSTRUCTIONS.
  - CONTACTS OFFSET FOR POLARIZATION.
  - REFER TO CRIMP SPECIFICATIONS PRINT FOR CRIMP AND STRIP DIMENSIONS, TOLERANCES, TOOLING AND ITS REQUIREMENTS.
  - FOR LENGTHS LESS THAN 12 IN, TOLERANCE SHALL BE ±.125[3.18]. FOR OTHER LENGTHS, TOLERANCES SHALL BE ± 2%.
  - GOLD PLATING IS NOT REQUIRED ON THE OUTSIDE OF THE CONTACT BOX OR ON THE SIDE WITH THE RETENTION LANCE.
  - ASSEMBLIES USING THE FEP OPTION ARE FOR CRIMP APPLICATIONS ONLY.
  - CUT LENGTH IS ASSEMBLY LENGTH MINUS OVERALL LENGTH SUBTRACTOR.

**MMSSX-XX-XXX-X-XX.XX-X-X-XXX**

**FEP CABLE OPTION**  
 -T: FEP INSULATION  
 (LEAVE BLANK FOR STANDARD PVC INSULATION)  
 (SEE NOTE 13)

**NO OF POSITIONS**  
 -02 THRU -25

**WIRE GAUGE (AWG)**  
 PVC:-20, -22, -24, -26, -28, -30  
 FEP:-20, -24, -28, 30

**COLOR CODE**  
 -C (SEE TABLE 2)  
 (LEAVE BLANK FOR STANDARD BLACK CABLE)  
 (NOT AVAILABLE FOR TEFLON OPTION, TEFLON CABLE ONLY AVAILABLE IN BLUE)

**PLATING SPECIFICATION**  
 -F: 3μ" SELECTIVE GOLD ON CONTACT AREA, BRIGHT ACID TIN ON TAIL (USE C-179-XX-F)  
 -L: 10μ" SELECTIVE GOLD ON CONTACT AREA, BRIGHT ACID TIN ON TAIL (USE C-179-XX-L)  
 -S: 30μ" SELECTIVE GOLD ON CONTACT AREA, BRIGHT ACID TIN ON TAIL (USE C-179-XX-S)

**OPTION**  
 SINGLE  
 -M: METAL LATCH (USE IPD1-XX-S-X-M) (LEAVE BLANK FOR PLASTIC)  
 DOUBLE  
 [MUST BE USED ON -D END OPTION ONLY & APPLIES TO END 2 HOUSING]  
 -LUS: PLASTIC LATCH UP, STRAIGHT  
 -LDS: PLASTIC LATCH DOWN, STRAIGHT  
 -MUS: METAL LATCH UP, STRAIGHT  
 -MDS: METAL LATCH DOWN, STRAIGHT  
**OPTION**  
 -K: KEYED POLARIZATION (USE IPD1-XX-S-K) (SEE FIG 3, SHEET 2) (LEAVE BLANK FOR NO POLARIZATION; AVAILABLE TO EXISTING CUSTOMERS ONLY)  
**END OPTION**  
 -S: SINGLE END  
 -D: DOUBLE END (MUST CHOOSE XUS OR XDS OPTIONS.)

**ASSEMBLED LENGTH**  
 SPECIFY IN INCHES [USE DWCX-XX-XX]  
 (SINGLE END: 03.00[76.2] INCH MINIMUM, DOUBLE END: 03.25[82.6] INCH MINIMUM)

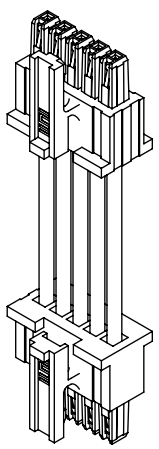
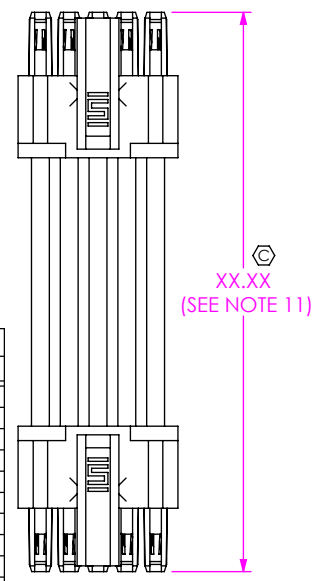
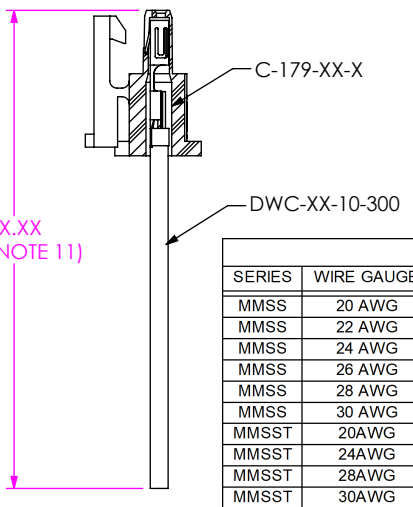
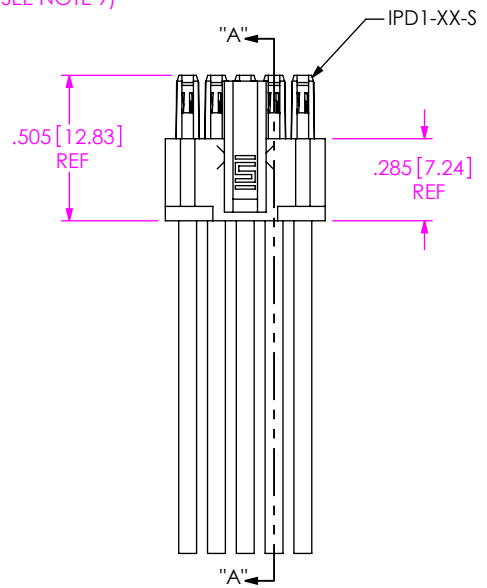
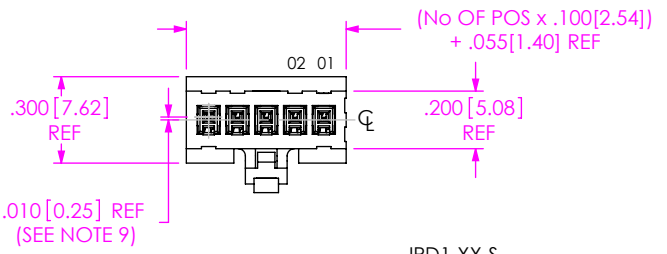

**FIG 1**  
 MMSS-05-22-X-XX.XX-S SHOWN

**SECTION "A"- "A"**

**FIG 2**  
 MMSS-05-22-X-XX.XX-D-LUS SHOWN

SERIES	WIRE GAUGE	CABLE	CONTACT	"A"
MMSS	20 AWG	DWC-20-XX-300	C-179-03-X	.128 [3.25]
MMSS	22 AWG	DWC-22-XX-300	C-179-03-X	.128 [3.25]
MMSS	24 AWG	DWC-24-XX-300	C-179-03-X	.128 [3.25]
MMSS	26 AWG	DWC-26-XX-300	C-179-02-X	.133 [3.38]
MMSS	28 AWG	DWC-28-XX-300	C-179-02-X	.133 [3.38]
MMSS	30 AWG	DWC-30-XX-300	C-179-02-X	.133 [3.38]
MMSST	20AWG	DWCT-20-XX-TC	C-179-03-X	.128 [3.25]
MMSST	24AWG	DWCT-24-XX-TC	C-179-03-X	.128 [3.25]
MMSST	28AWG	DWCT-28-XX-TC	C-179-04-X	.128 [3.25]
MMSST	30AWG	DWCT-30-XX-TC	C-179-04-X	.128 [3.25]

PIN #	COLOR									
	BROWN	RED	ORANGE	YELLOW	GREEN	BLUE	VIOLET	GRAY	WHITE	BLACK
	DWC-XX-01-300	DWC-XX-02-300	DWC-XX-03-300	DWC-XX-04-300	DWC-XX-05-300	DWC-XX-06-300	DWC-XX-07-300	DWC-XX-08-300	DWC-XX-09-300	DWC-XX-10-300
1	2	3	4	5	6	7	8	9	10	
11	12	13	14	15	16	17	18	19	20	
21	22	23	24	25						

F:\DWG\SW\Exisprod\Assembly\100\MMSSX-XX-XXX-X-XX.XX-X-X-XXX-ASM.SLDDRW

UNLESS OTHERWISE SPECIFIED, DIMENSIONS ARE IN INCHES. TOLERANCES ARE:  
 DECIMALS ANGLES  
 .XX: ±.01 [0.3] 2°  
 .XXX: ±.005 [0.13]  
 .XXXX: ±.0020 [0.051]

**PROPRIETARY NOTE**  
 THIS DOCUMENT CONTAINS CONFIDENTIAL AND PROPRIETARY INFORMATION AND ALL DESIGN, MANUFACTURING, REPRODUCTION, USE, PATENT RIGHTS AND SALES RIGHTS ARE EXPRESSLY RESERVED BY SAMTEC, INC. THIS DOCUMENT SHALL NOT BE DISCLOSED, IN WHOLE OR PART, TO ANY UNAUTHORIZED PERSON OR ENTITY NOR REPRODUCED, TRANSFERRED OR INCORPORATED IN ANY OTHER PROJECT IN ANY MANNER WITHOUT THE EXPRESS WRITTEN CONSENT OF SAMTEC, INC.

**MATERIAL:** DO NOT SCALE DRAWING SHEET SCALE: 1.5:1  
 HOUSING: NYLON 6/6, COLOR: WHITE  
 CONTACT: PHOS BRONZE  
 CABLE: INSULATION: SEE CALLOUT  
 WIRE: TINNED COPPER



520 PARK EAST BLVD, NEW ALBANY, IN 47150  
 PHONE: 812-944-6733 FAX: 812-948-5047  
 e-Mail info@SAMTEC.com code 55322

**DESCRIPTION:**  
 .100[2.54] SOCKET DISCREET CABLE ASSEMBLY

DWG. NO.  
**MMSSX-XX-XXX-X-XX.XX-X-X-XXX**

BY: DEAN P 05/03/2005 SHEET 1 OF 3

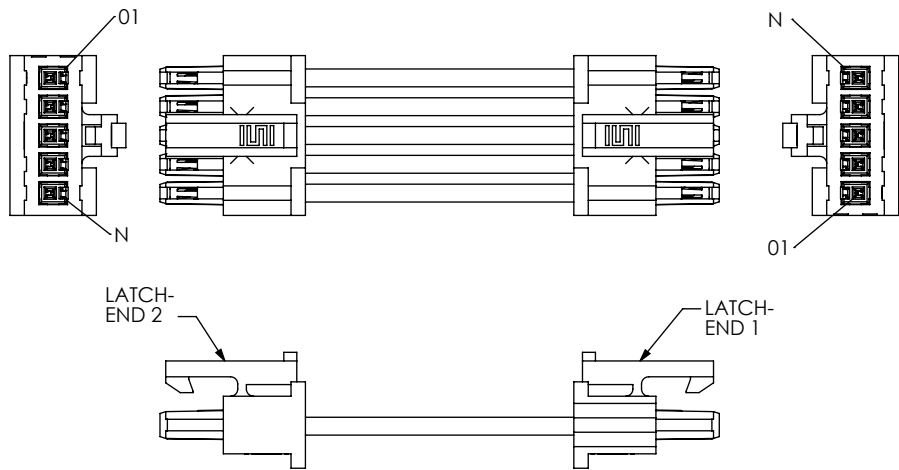

-LUS  
[LATCH UP- CABLE STRAIGHT]

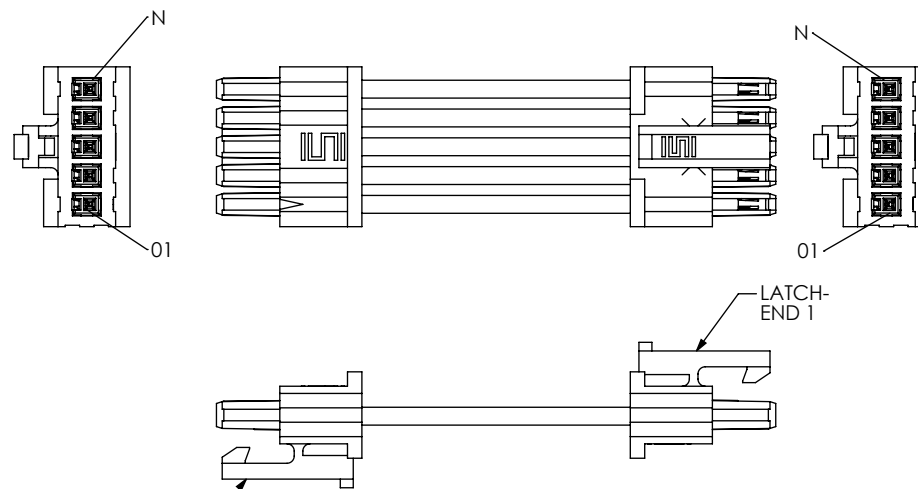

-LDS  
[LATCH DOWN- CABLE STRAIGHT]

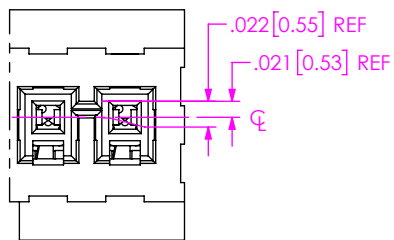
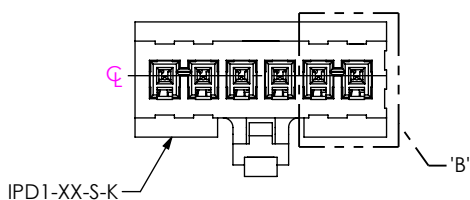

FIG 3  
-K: KEYED POLARIZATION  
(MMSSX-06-XX-X-XX.XX-X-K-XXX SHOWN)  
(SAME AS FIG 1, UNLESS OTHERWISE STATED)

<p><b>PROPRIETARY NOTE</b></p> <p>THIS DOCUMENT CONTAINS CONFIDENTIAL AND PROPRIETARY INFORMATION AND ALL DESIGN, MANUFACTURING, REPRODUCTION, USE, PATENT RIGHTS AND SALES RIGHTS ARE EXPRESSLY RESERVED BY SAMTEC, INC. THIS DOCUMENT SHALL NOT BE DISCLOSED, IN WHOLE OR PART, TO ANY UNAUTHORIZED PERSON OR ENTITY NOR REPRODUCED, TRANSFERRED OR INCORPORATED IN ANY OTHER PROJECT IN ANY MANNER WITHOUT THE EXPRESS WRITTEN CONSENT OF SAMTEC, INC.</p>	<p><b>samtec</b></p> <p>520 PARK EAST BLVD, NEW ALBANY, IN 47150 PHONE: 812-944-6733 FAX: 812-948-5047 e-Mail info@SAMTEC.com code 55322</p>	
	<p>DO NOT SCALE DRAWING</p> <p>SHEET SCALE: 1.5:1</p>	<p>DESCRIPTION: .100[2.54] SOCKET DISCREET CABLE ASSEMBLY</p> <p>DWG. NO. MMSSX-XX-XXX-X-XX.XX-X-X-XXX</p> <p>BY: DEAN P 05/03/2005 SHEET 2 OF 3</p>

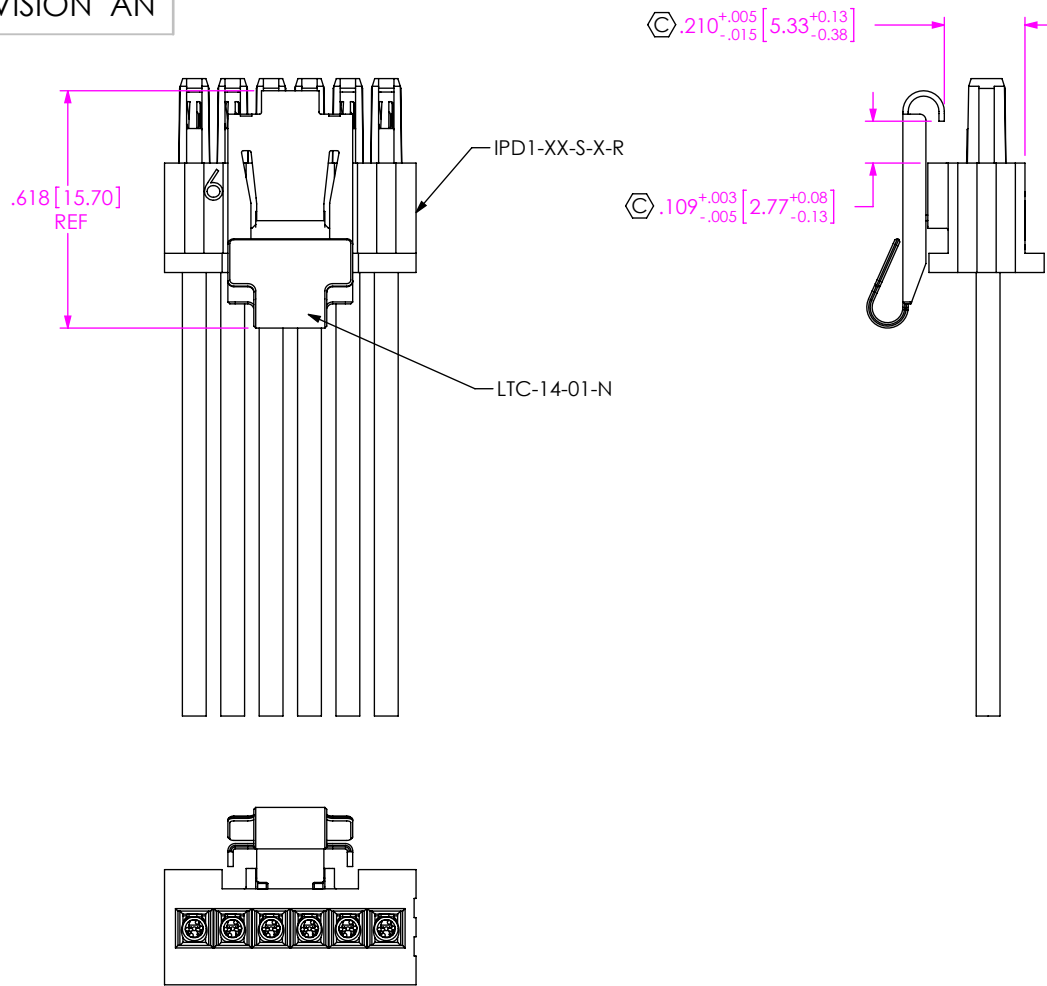
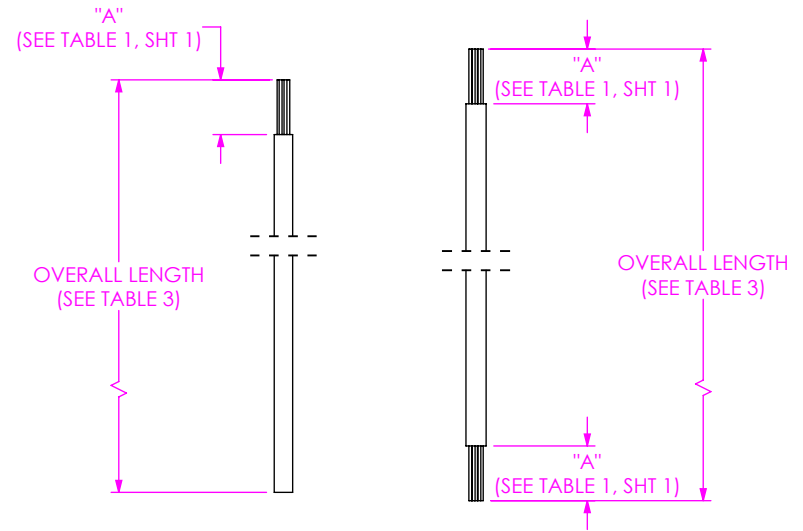

FIG 4  
(MMSSX-06-XX-X-XX.XX-S-M SHOWN)  
(SAME AS FIG 1, UNLESS OTHERWISE STATED)



-S: SINGLE END    -D: DOUBLE END

CABLE CUT IN-PROCESS

TABLE 3 ( OVERALL LENGTH SUBTRACTORS) (SEE NOTE 14)	
	LENGTH
-S: SINGLE END	.250 [6.35]
-D: DOUBLE END	.500 [12.70]

**PROPRIETARY NOTE**

THIS DOCUMENT CONTAINS CONFIDENTIAL AND PROPRIETARY INFORMATION AND ALL DESIGN, MANUFACTURING, REPRODUCTION, USE, PATENT RIGHTS AND SALES RIGHTS ARE EXPRESSLY RESERVED BY SAMTEC, INC. THIS DOCUMENT SHALL NOT BE DISCLOSED, IN WHOLE OR PART, TO ANY UNAUTHORIZED PERSON OR ENTITY NOR REPRODUCED, TRANSFERRED OR INCORPORATED IN ANY OTHER PROJECT IN ANY MANNER WITHOUT THE EXPRESS WRITTEN CONSENT OF SAMTEC, INC.



520 PARK EAST BLVD, NEW ALBANY, IN 47150  
PHONE: 812-944-6733    FAX: 812-948-5047  
e-Mail: info@SAMTEC.com    code 55322

DO NOT SCALE DRAWING

SHEET SCALE: 1:1

DESCRIPTION:  
.100[2.54] SOCKET DISCREET CABLE ASSEMBLY

DWG. NO.  
MMSSX-XX-XXX-X-XX.XX-X-X-XXX

BY: DEAN P    05/03/2005    SHEET 3 OF 3