

THIS DRAWING IS UNPUBLISHED. RELEASED FOR PUBLICATION 20
 © COPYRIGHT 20 BY - ALL RIGHTS RESERVED.

ITEM	DESCRIPTION	MATERIAL	OTHERS
1	FEMALE CONTACT	COPPER ALLOY	GOLD PLATED
2	HOUSING	NYLON	BLACK
3	COUPLING NUT	ZAMAK	NICKEL PLATED
4	OVER-MOLDING	PVC	BLACK
5	SHIELDED SHELL	COPPER ALLOY	NICKEL PLATED
6	O-RING	SILICONE	GRAY
7	CABLE	PVC JACKET	RED
8	LABEL	-	-

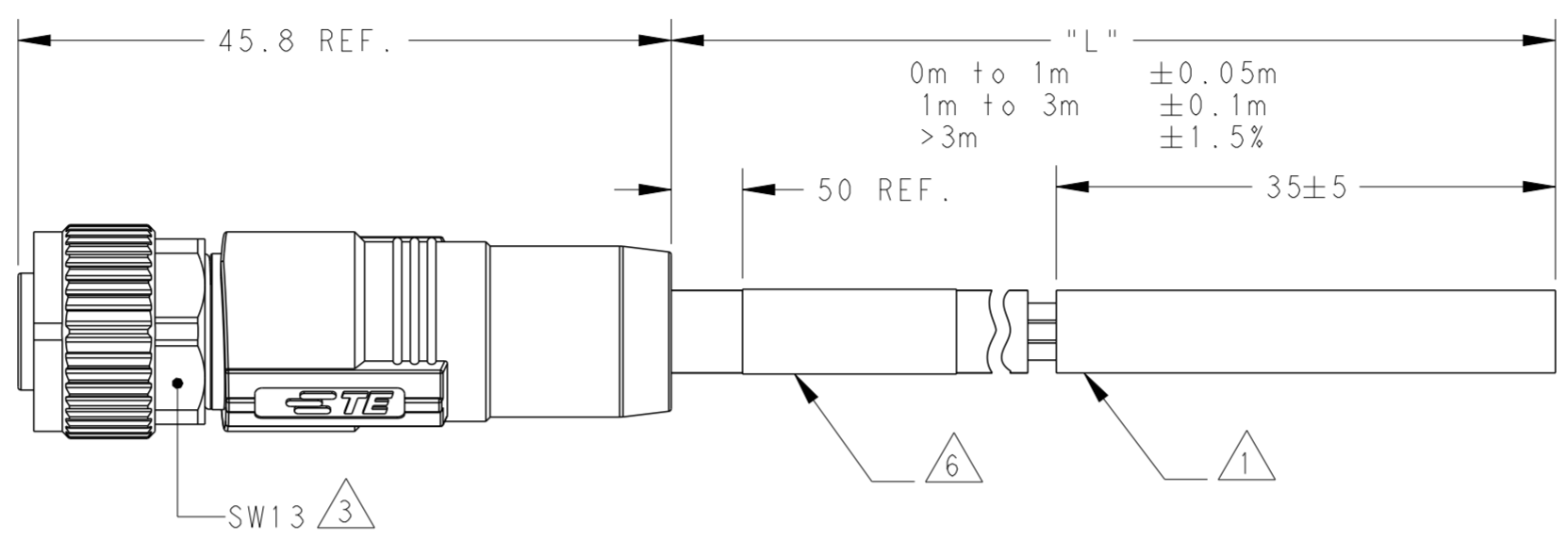
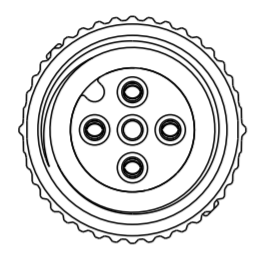

REVISIONS				
P	LTR	DESCRIPTION	DATE	APVD
A		INITIAL RELEASE	29JUL2019	A.Z C.W
A1		CLARIFY TYPICAL PNS	22JUN2020	A.Z C.W
B		ECR-22-134232	08JUN2025	B.P C.W

NOTE:
 1. STRIP AND RETAIN THE INSULATION
 2. CODE POSITION INDICATOR
 3. RECOMMENDED TORQUE 0.6 Nm
 4. -** : CABLE LENGTH, FOR EXAMPLE: -0.5M
 5. CABLE ASSEMBLY TO BE PACKAGED IN POLYBAGS
 6. LABEL CONTAINS: PN, DATE CODE...

注释:
 1. 剥线并保留护套绝缘层
 2. CODE位置指示
 3. 推荐扭矩0.6 Nm
 4. -** : 线缆长度, 例如: -0.5M
 5. 线缆组件塑料袋包装
 6. 标签包含: 产品编号, 日期代码...

TE PN CODING:

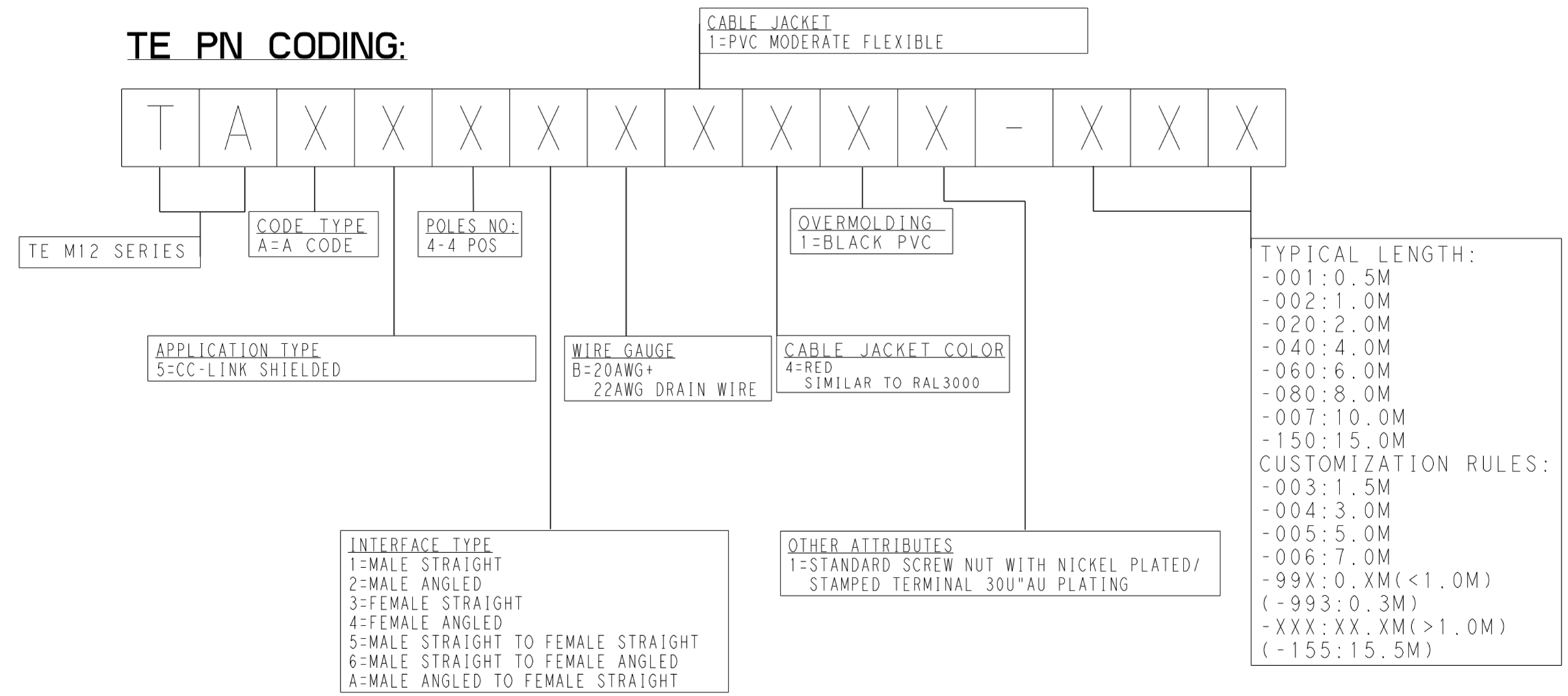
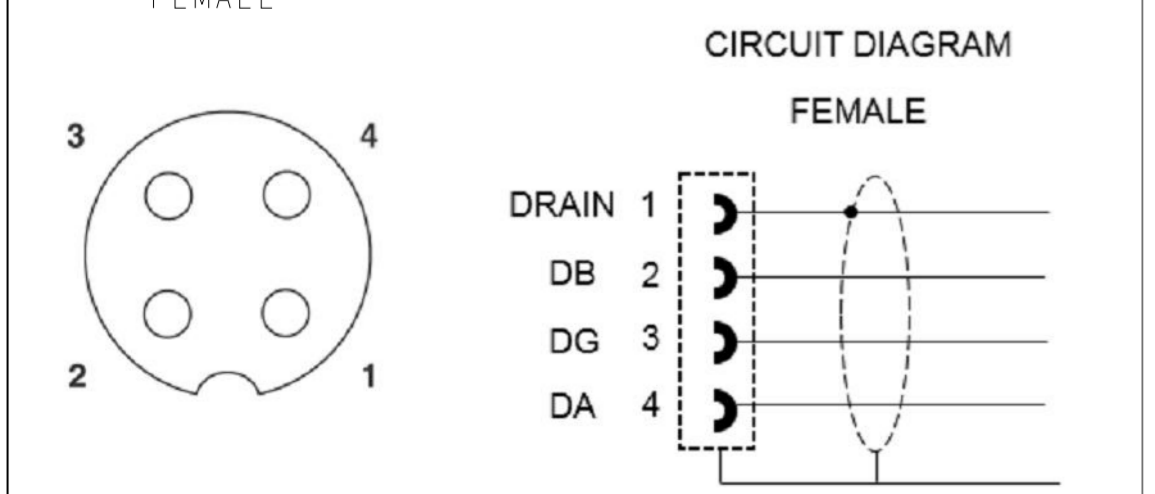

TABLE 1
 TECHNICAL DATA

RATED VOLTAGE	250V
RATED IMPULSE VOLTAGE	2500V
RATED CURRENT	4A
POLLUTION DEGREE	3
OVERVOLTAGE CATEGORY	II
MATERIAL GROUP	II
DEGREE OF PROTECTION	IP67

PIN ARRANGEMENT
 A-CODE

PIN 1	DRAIN	BARE
PIN 2	DB	WHITE
PIN 3	DG	YELLOW
PIN 4	DA	BLUE



WIRES: 3X20AWG+1X22AWG DRAIN WIRE WIRE COLOR: BLUE/YELLOW/WHITE OD: APPROX. 7.7MM TEMPERATURE RATING: 75°C UL OPERATING TEMP RATING: -30°C To +60°C	TYPICAL LENGTH: -001: 0.5M -002: 1.0M -020: 2.0M -040: 4.0M -060: 6.0M -080: 8.0M -007: 10.0M -150: 15.0M CUSTOMIZATION RULES: -003: 1.5M -004: 3.0M -005: 5.0M -006: 7.0M -99X: 0.XM (<1.0M) (-993: 0.3M) -XXX: XX.XM (>1.0M) (-155: 15.5M)	M12A4-FS-PVC-**△	TAA543B1411-XXX
CABLE CHARACTERISTIC	LENGTH "L"	TYPE	TE PN

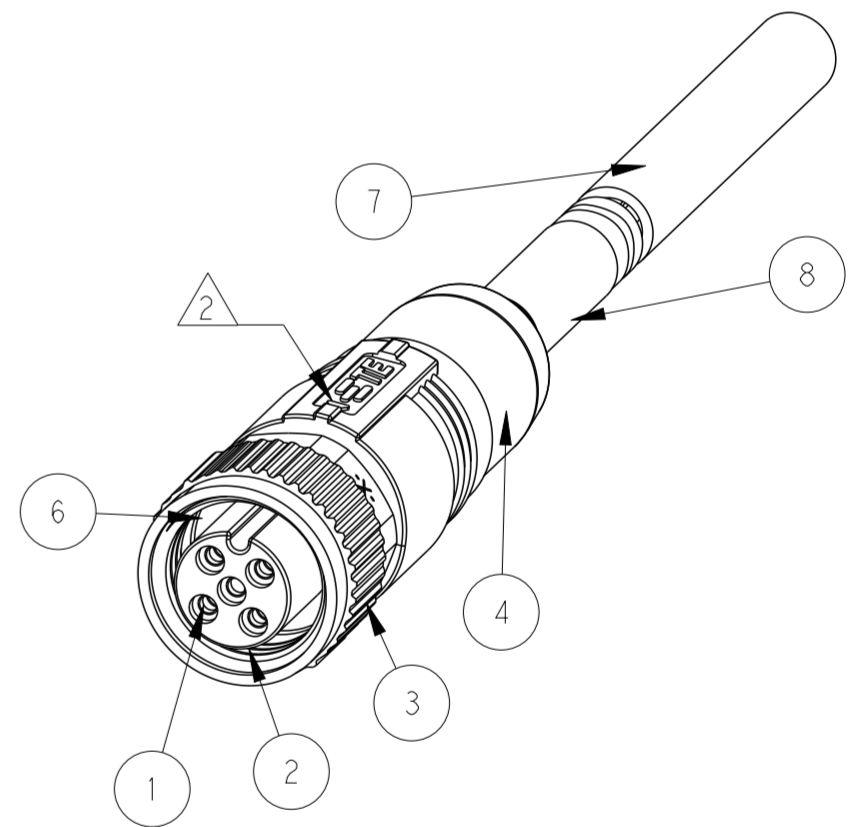

THIS DRAWING IS A CONTROLLED DOCUMENT.		DWN 11APR2019 ALEX ZHANG	TE Connectivity	
DIMENSIONS: mm		CHK 11APR2019 HART HE		
TOLERANCES UNLESS OTHERWISE SPECIFIED:		APVD 11APR2019 CHRIS WANG	NAME M12 A CODE CABLE ASSY, SHIELDED 4P, FS FREE END	
0 PLC ± 1 PLC ± 2 PLC ± 3 PLC ± 4 PLC ± ANGLES ±		PRODUCT SPEC 108-106140	SIZE A2	
MATERIAL		APPLICATION SPEC 114-137144	DRAWING NO C-TAA543B1411XXX	
FINISH		WEIGHT	RESTRICTED TO	
		CUSTOMER DRAWING	SCALE 2:1 SHEET 1 OF 1 REV B	