

THIS DRAWING IS UNPUBLISHED.

RELEASED FOR PUBLICATION

© COPYRIGHT 2020 TE Connectivity Ltd.

ALL RIGHTS RESERVED.

REVISIONS

P	LTR	DESCRIPTION	DATE	DWN	APVD
	3	TABLE DIMENSIONS UPDATED	15APR2026	GSK	AK

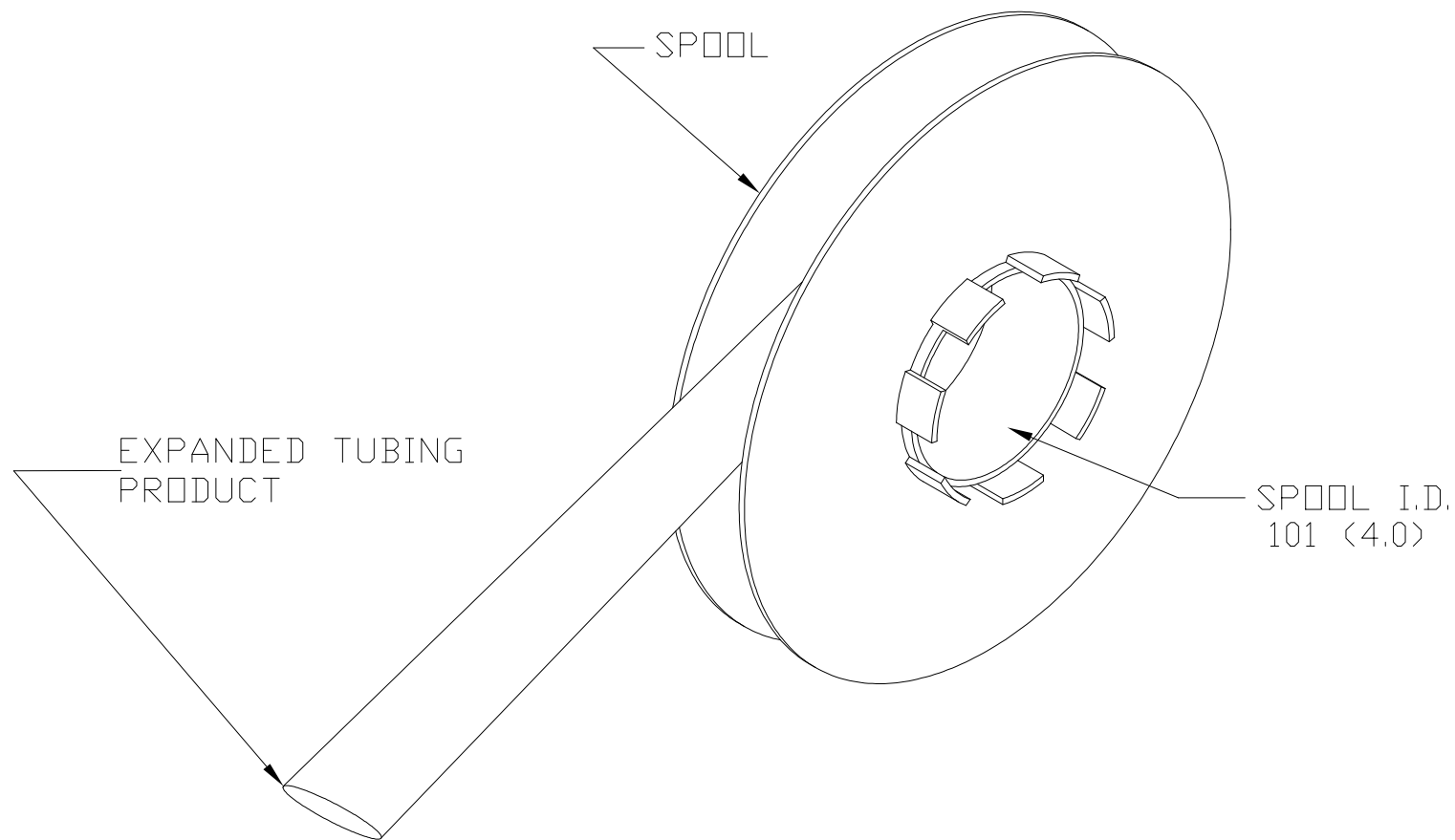
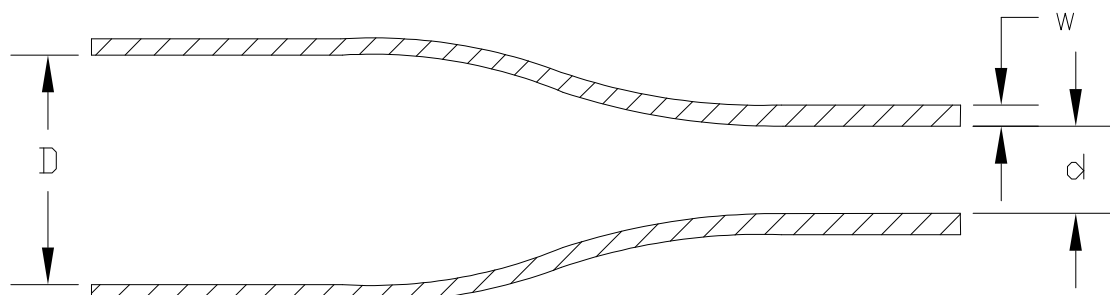
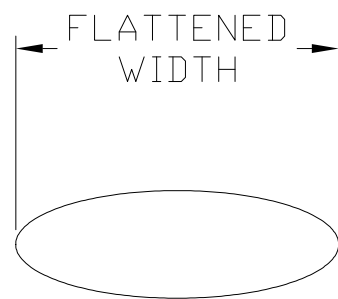

Product Size	2.4	3.2	4.8	6.4	9.5	12	18	25	38
"D" Minimum Supplied I.D.	2.40 (.094)	3.20 (.126)	4.80 (.189)	6.40 (.252)	9.50 (.374)	12.70 (.500)	19.05 (.750)	25.40 (1.00)	38.10 (1.50)
"d" Maximum Recovered I.D.	0.8 (.031)	1.1 (.043)	1.6 (.063)	2.1 (.083)	3.2 (.126)	4.2 (.165)	6.4 (.252)	8.5 (.335)	19.1 (.752)
"w" Recovered Wall Thickness ±0.08 (.003)	0.51 (.020)	0.51 (.020)	0.58 (.023)	0.58 (.023)	0.61 (.024)	0.61 (.024)	0.61 (.024)	0.64 (.025)	0.64 (.025)
Minimum Sleeve Flattened Width	4.45 (.175)	5.84 (.230)	8.00 (.315)	10.67 (.420)	15.49 (.610)	20.45 (.805)	30.48 (1.201)	40.39 (1.591)	60.33 (2.375)

NOTES:

1. ALL DIMENSIONS ARE IN MILLIMETERS (inches).
2. ONE SPLICE PER SPOOL PERMITTED. BOX IS MARKED WHERE APPLICABLE

THIS DRAWING IS A CONTROLLED DOCUMENT.		DWN AFK CHK -	09JAN2020	TE Connectivity NAME D-CT OUTSIDE PRINTER SPOOL	
DIMENSIONS: mm		TOLERANCES UNLESS OTHERWISE SPECIFIED:			
		0 PLC ± -		PRODUCT SPEC RW-2519	
		1 PLC ± -		APPLICATION SPEC	
MATERIAL CROSSLINKED POLYOLEFIN		2 PLC ± -		SIZE A3	
		3 PLC ± -		CAGE CODE 0198G	
FINISH -		4 PLC ± -		DRAWING NO C-MCD170014	
		ANGLES ± -		RESTRICTED TO -	
CUSTOMER DRAWING		WEIGHT VARIOUS		SCALE -	
		SHEET 1 OF 1		REV 3	