

DRAWING MADE IN THIRD ANGLE PROJECTION

THIS DRAWING IS UNPUBLISHED. RELEASED FOR PUBLICATION .19
 © COPYRIGHT 19 BY AMP INCORPORATED. ALL INTERNATIONAL RIGHTS RESERVED.

LOC	DIST	P	F	REVISIONS				
				ZONE	LTR	DESCRIPTION	DATE	APPD
AF	50				U1	REVISED PER ECR-25-262681	03MAR2026	DB/DH

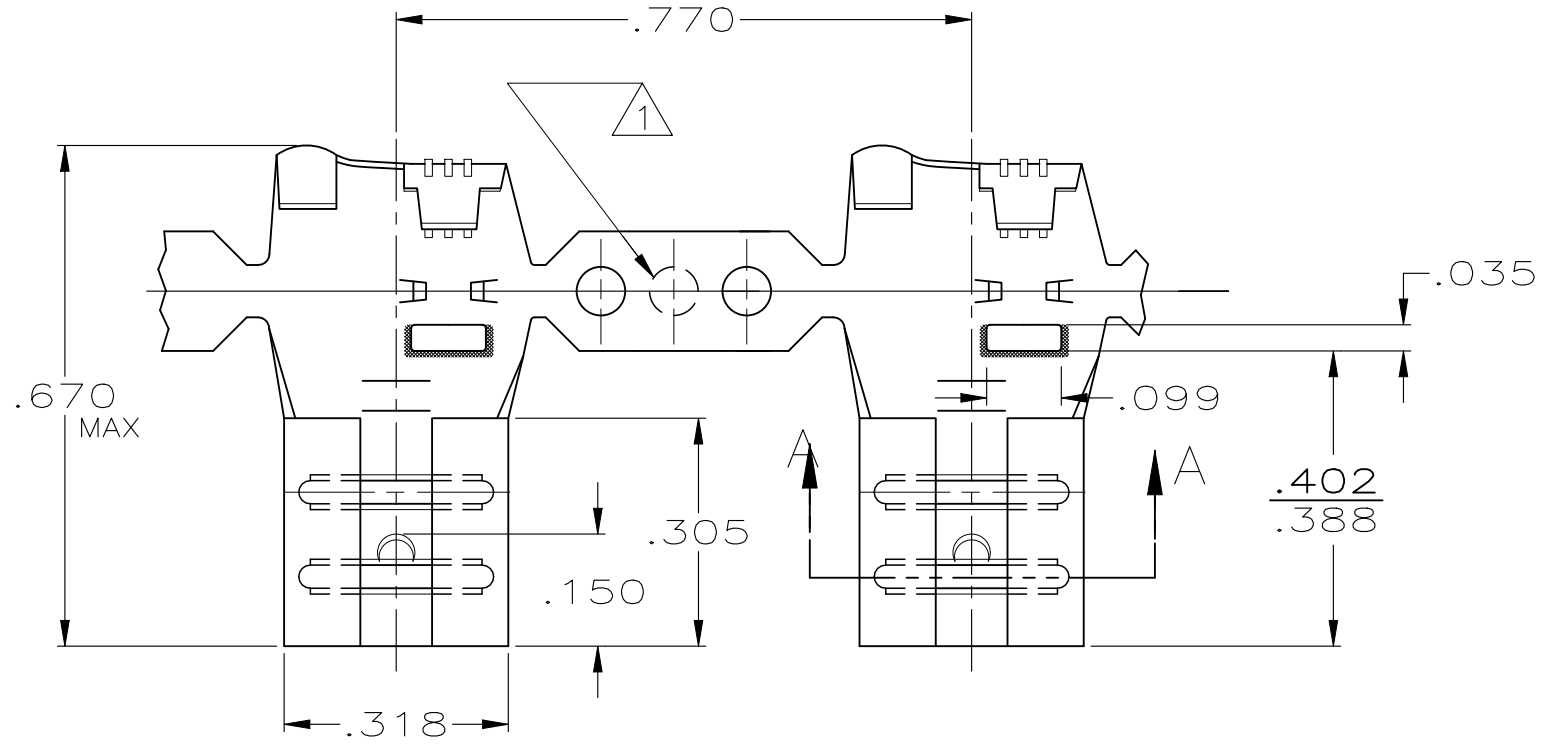

- 1 SINGLE OR DOUBLE PILOT HOLE OPTIONAL
- 2 MAX FIRST INSERTION FORCE, 20 LBS. USING GAGE 100505.

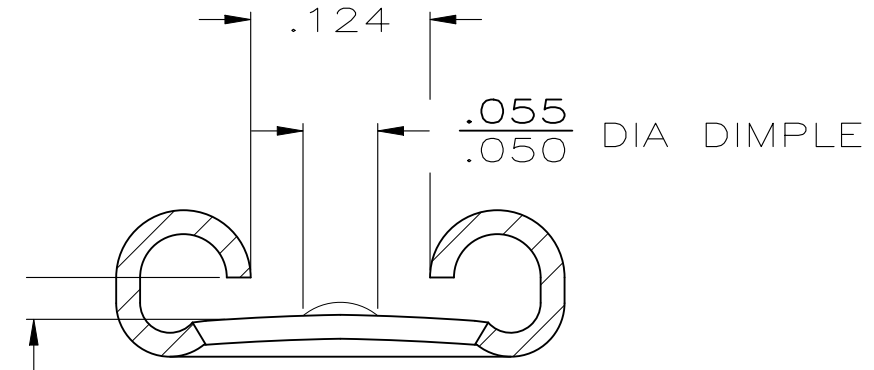

SECTION A-A
SCALE 8:1

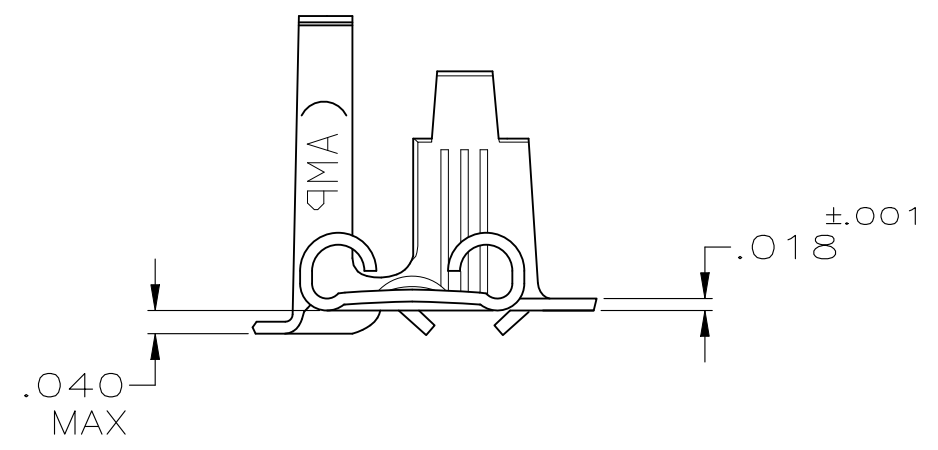

.110-.210	18-12	.032	42041
INSULATION RANGE	WIRE SIZE	MATING TAB THK ±.001	PART NUMBER
DO NOT SCALE PRINT. UNLESS SPECIFIED DIMENSIONS IN INCHES TOLERANCES ON: 2 PLC DEC ± - 3 PLC DEC ± .015 ANGLES ± - MATERIAL #3H PHOS BRZ FINISH SILVER	DR 7/12/89 JR RUTH	TE TE Connectivity	
	CHK 7/12/89 MS FEHER		
	APPD 7/12/89 C MEYERS	NAME RECEPTACLE, FASTON, FLAG, .250 SERIES	
	APPD 7/12/89 R KUZO	PRODUCT SPEC -	SIZE B
	APPLICATION SPEC -	DRAWING NO 42041	
	WEIGHT -	SCALE 4:1	SHEET 1 OF 1