

REVISIONS				
P	LTN	DESCRIPTION	DATE	APVD
A		REVISED PER ECN-24-276632	08AUG2024	DK CL

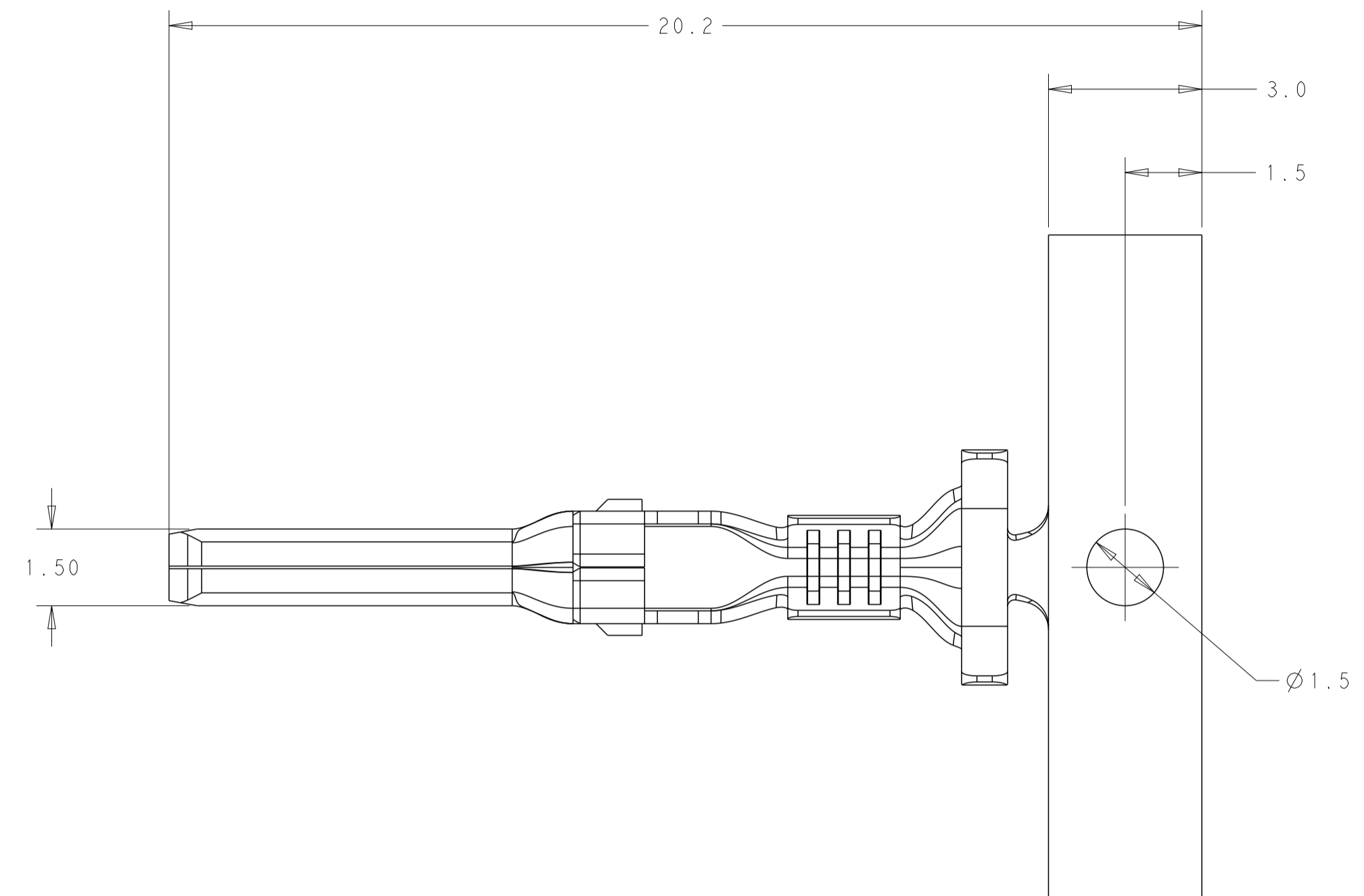

- 1 MATERIAL: SEE TABLE
- 2 RECOMMENDED MATING PART: 2391515-2, 2391515-3, 2391515-4, 2391517-1, 2391518-1, 2416056-2, 2391520-1
- 3 PACKAGING: ON REEL
- 4 REFERENCE CRIMP INFORMATION:  
WIRE RANGE: 20-24AWG COPPER STRANDED  
INSULATION RANGE: 1.4-2.0mm

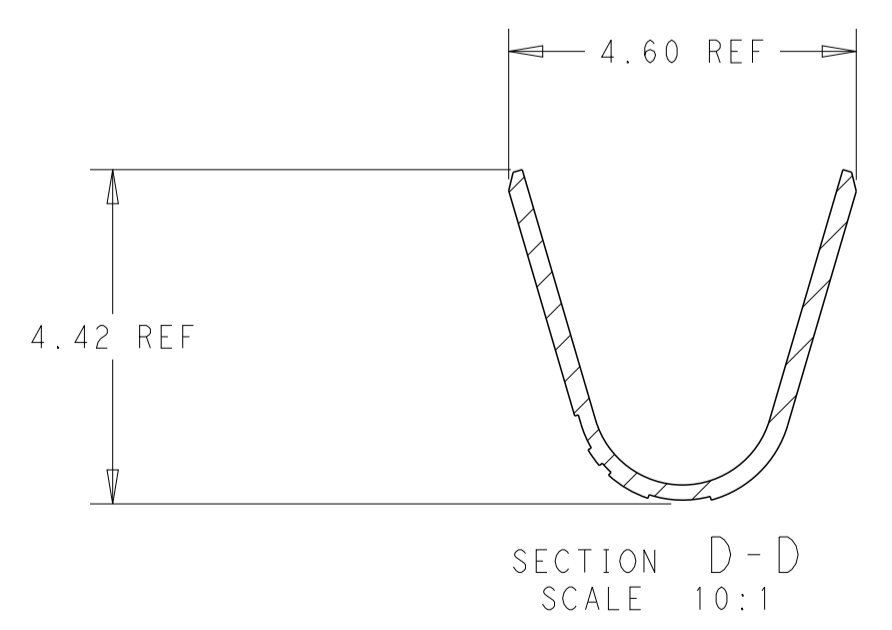
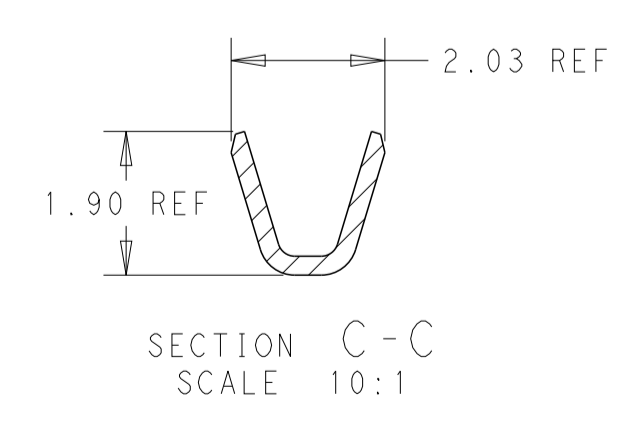
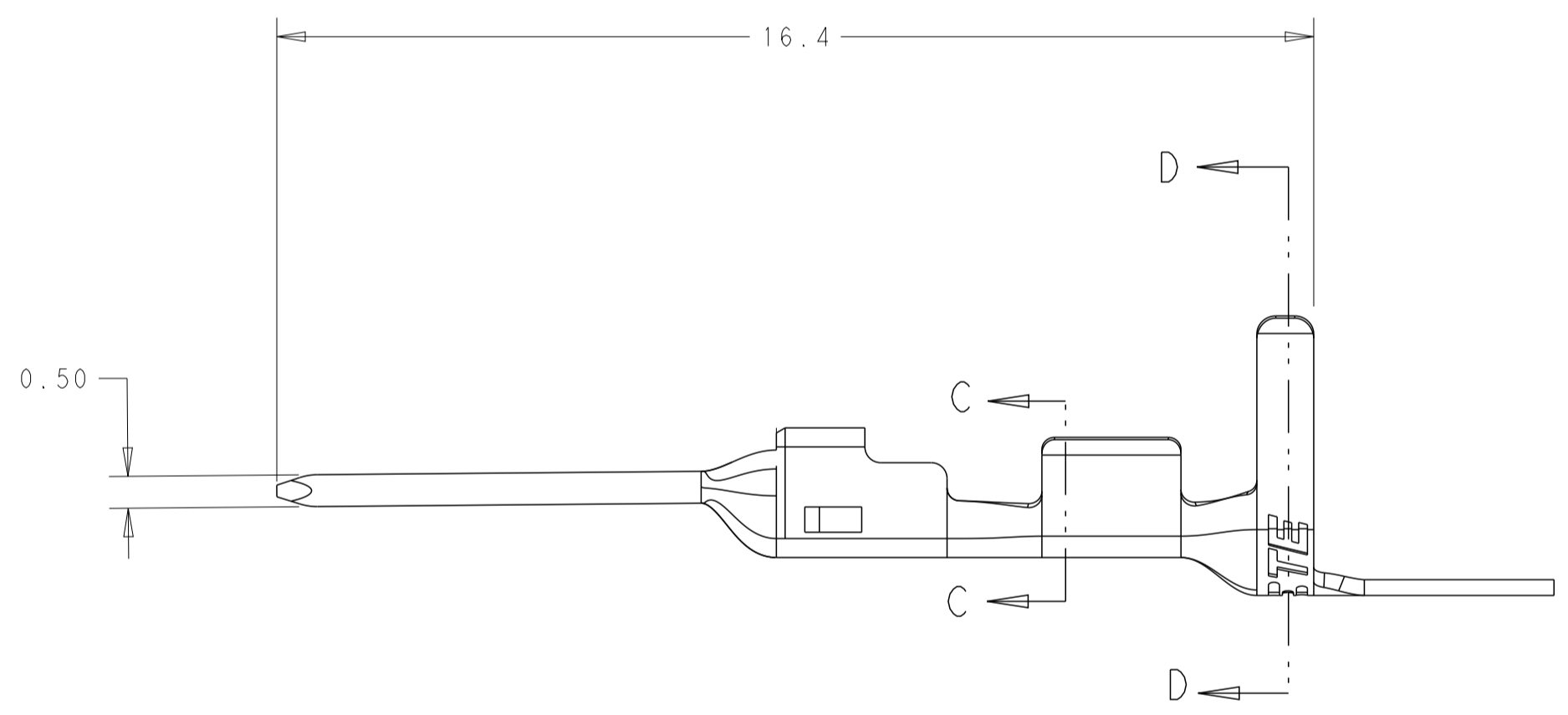
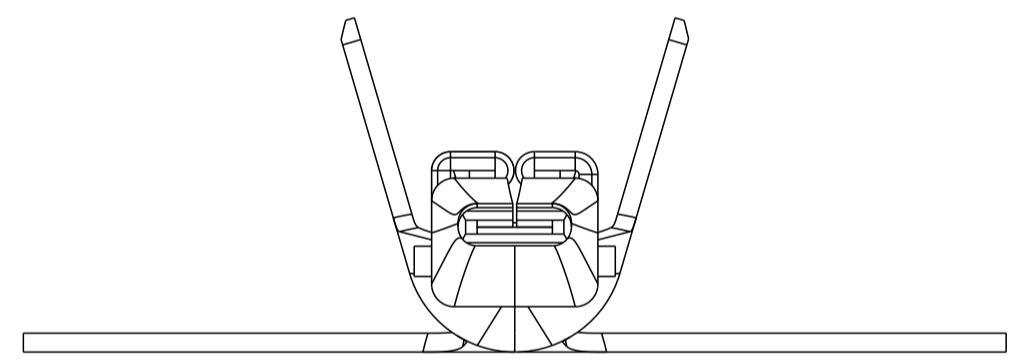

TIN PRE-PLATED	BRASS, 0.25 THICK	2406088-1
FINISH	MATERIAL	PART NO

THIS DRAWING IS A CONTROLLED DOCUMENT.		DWN: 01-12-2023 RAMBALL SANTOSH	TE Connectivity	
DIMENSIONS: mm		CHK: 01-12-2023 OTTO CHEN		
TOLERANCES UNLESS OTHERWISE SPECIFIED:		APVD: 01-12-2023 DANIEL Z	NAME: TAB TERMINAL 20-24AWG, POWER DOUBLE LOCK	
0 PLC ±	1 PLC ±0.40	PRODUCT SPEC	-	
2 PLC ±0.30	3 PLC ±	108-160365	-	
4 PLC ±	ANGLES ±	APPLICATION SPEC	-	
FINISH	WEIGHT	114-160773	SIZE: A	CAGE CODE: -
SEE TABLE	SEE TABLE	CUSTOMER DRAWING	SCALE: 10:1	SHEET 1 OF 1