

© - TE Connectivity. All Rights Reserved.  
 Tooling Drawing NO.  
 USB A: TR00662  
 USB B: TR00664

REVISIONS					
P	LTR	DESCRIPTION	DATE	DWN	APVD
	D3	REVISED PER ECN-22-178360	100CT2022	AP	YX

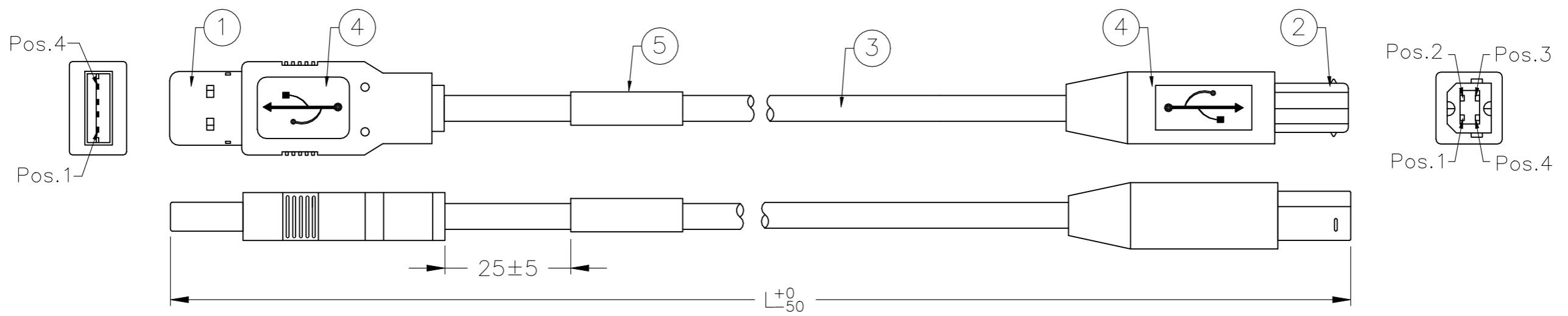

PIN ASSIGNMENT :

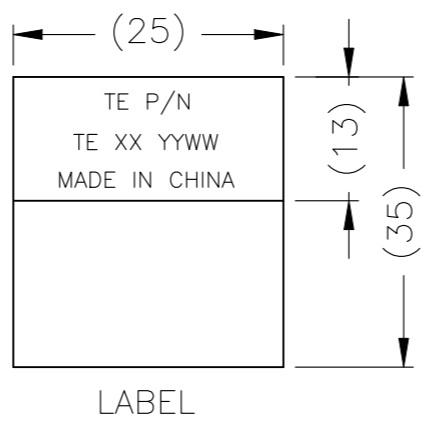
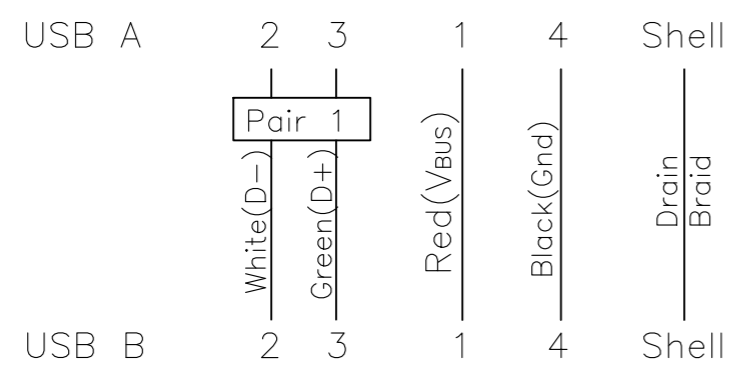

PART NO.	1487596-1	1487596-2	1487596-3	1487596-4
LENGTH(L)	2000	1500	1829	1000

QTY	DESCRIPTION	ITEM				
6	COPPER FOIL, W: 5MM	6				
5	LABEL, 25x35mm, White 25x13mm	5				
4	Overmold PVC, 40P, Color: Black(BK01)	4				
3	USB 2.0 Cable 28AWG*1P+24AWG*2C+Al/Mylar +Drain+Braid, Color: Black(BK01).	3				
2	USB 4Pin Connector Contacts: Gold 30U Plated, Shell: Nickel Plated, Housing UL94V-0 B Type.	2				
1	USB 4Pin Connector Contacts: Gold 30U Plated, Shell: Nickel Plated, Housing UL94V-0 A Type.	1				
-4	-3	-2	-1	U/M	DESCRIPTION	ITEM

- NOTES:
- TESTED FOR CONTINUITY, SHORTS AND OPENS, HI-POT 630V FOR 10MS.
  - CABLE ASSEMBLY MEETS USB 2.0 STANDARDS.
  - EXPOSED CABLE BRAID IS NOT PERMISSIBLE BEYOND OVERMOLD.
  - THE FINAL CABLE ASSEMBLY MAXIMUM LENGTH NOT TO EXCEED 2700MM PER USB SPECIFICATIONS.
  - MEETS REQUIREMENTS OF EU DIRECTIVE 2002/95/EC

THIS DRAWING IS A CONTROLLED DOCUMENT.

DIMENSIONS: mm

TOLERANCES UNLESS OTHERWISE SPECIFIED:

0 PLC	± -
1 PLC	± -
2 PLC	± -
3 PLC	± -
4 PLC	± -
ANGLES	± -
FINISH	± -

MATERIAL: -

APPROVALS:

DWN	BOVEY LIU	25/FEB/02
CHK	-	-
APVD	F.D. McCORKEL	15/MAR/02

PRODUCT SPEC: -

APPLICATION SPEC: -

WEIGHT: -

CUSTOMER DRAWING

SCALE: N.T.S.

SHEET: 1 OF 1

REV: D3

TE Connectivity

CABLE ASSEMBLY, USB A TYPE TO USB B TYPE

SIZE: A3

CAGE CODE: 00779

DRAWING NO: C-1487596

RESTRICTED TO: -