

REVISIONS					
P	LTR	DESCRIPTION	DATE	DWN	APVD
L1		ECR-25-266219	22DEC2025	ABS	PS

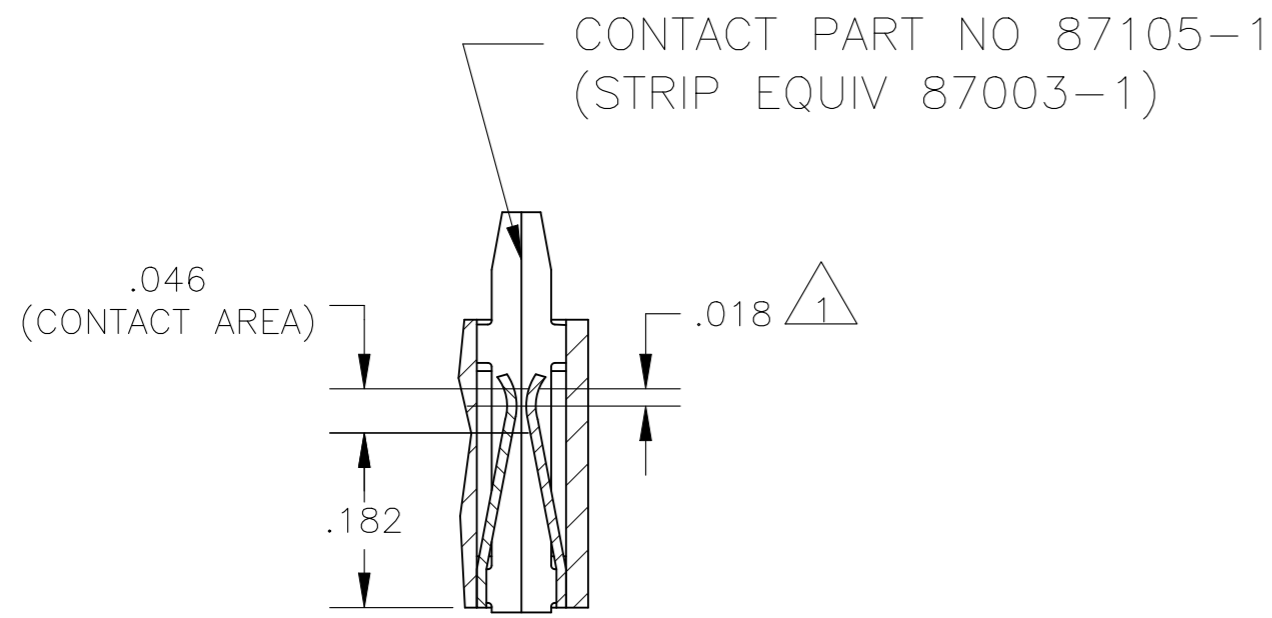

SECTION X-X

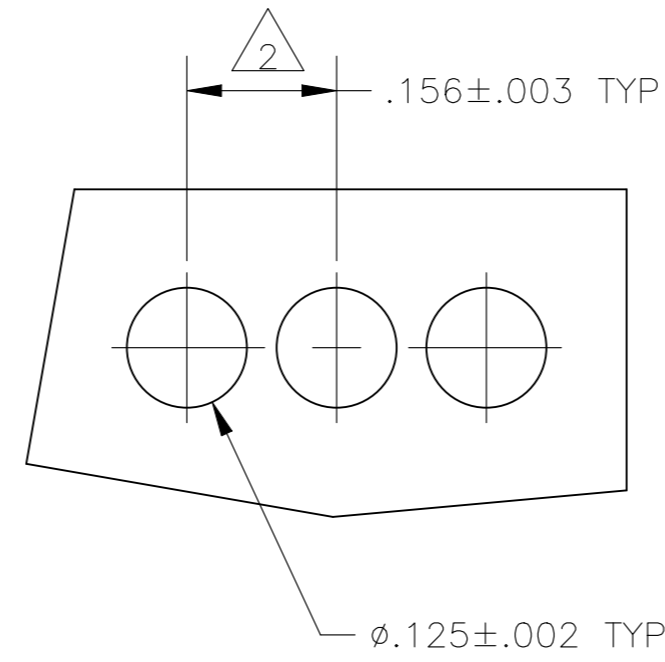

RECOMMENDED BOARD MOUNTING
(RECOMMENDED BOARD THICKNESS: .055-.070)

- △1 POINT OF MEASUREMENT FOR PLATING THICKNESS (INSIDE OF BEAMS).
- △2 TOLERANCE NON-CUMULATIVE.
- △3 THE MATING END OF THE CONTACT IS IDENTIFIED BY THE LETTER "A" STAMPED ON THE RECEPTACLE BOX.
- △4 OBSOLETE PARTS: OBSOLETE CIS STREAMLINING PER D.RENAUD/D.SINISI

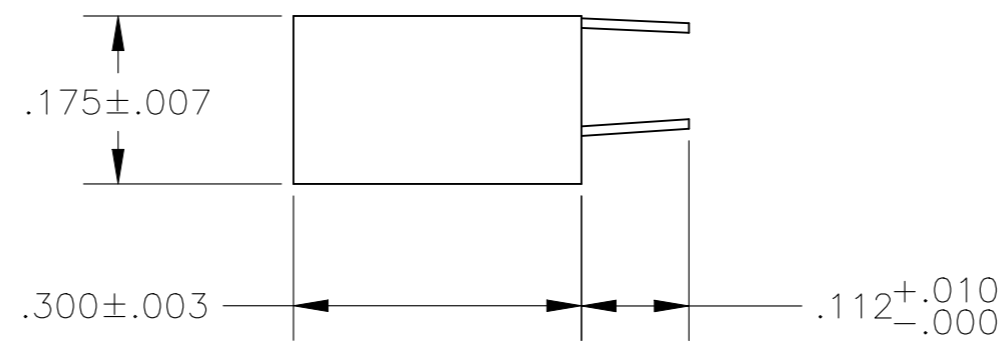
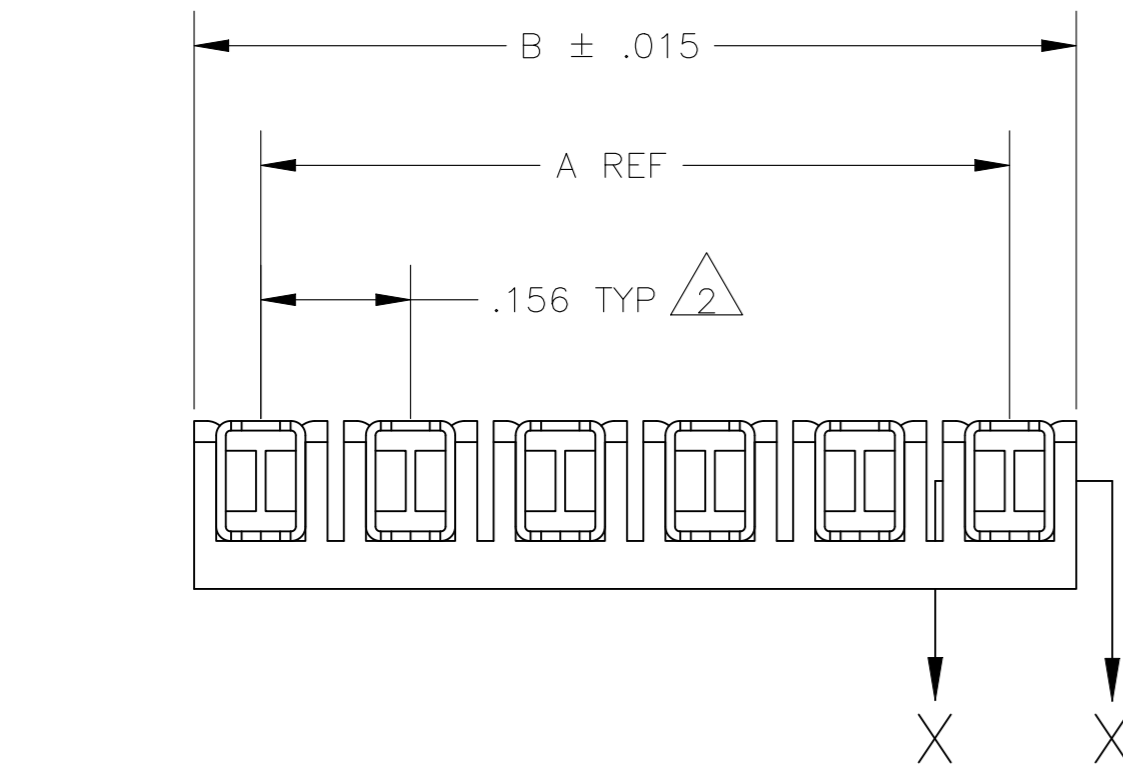
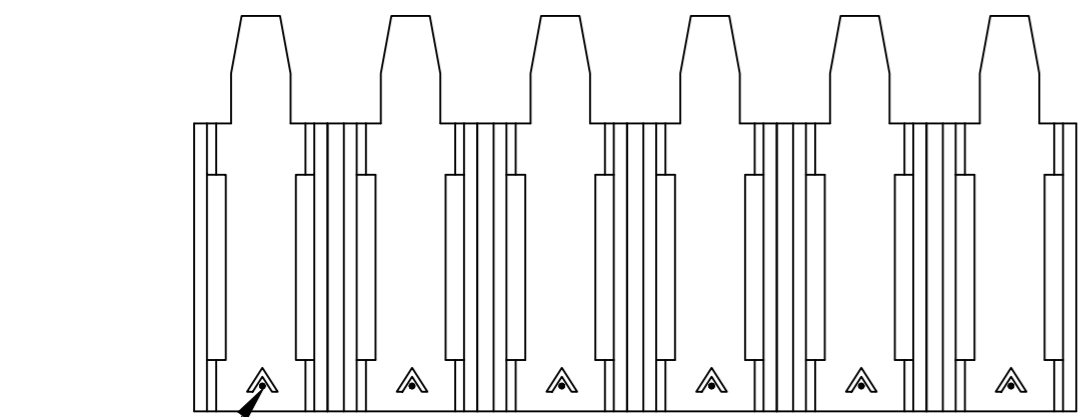

OBSOLETE △4	3.120	2.964	20	2-87986-0
	2.964	2.808	19	1-87986-9
	2.808	2.652	18	1-87986-8
	2.652	2.496	17	1-87986-7
	2.496	2.340	16	1-87986-6
	2.340	2.184	15	1-87986-5
OBSOLETE	2.184	2.028	14	1-87986-4
△4 OBSOLETE	2.028	1.872	13	1-87986-3
OBSOLETE	1.872	1.716	12	1-87986-2
△4 OBSOLETE	1.716	1.560	11	1-87986-1
OBSOLETE	1.560	1.404	10	1-87986-0
OBSOLETE △4	1.404	1.248	9	87986-9
	1.248	1.092	8	87986-8
	1.092	.936	7	87986-7
	.936	.780	6	87986-6
	.780	.624	5	87986-5
	.624	.468	4	87986-4
△4 OBSOLETE	.468	.312	3	87986-3
OBSOLETE	.312	.156	2	87986-2
	B	A	NO OF POSN	ASSEMBLY PART NUMBER

THIS DRAWING IS A CONTROLLED DOCUMENT.		DWN	L D RINGLEY	17MAR86
DIMENSIONS: INCHES		CHK	P deJONG	18MAR86
TOLERANCES UNLESS OTHERWISE SPECIFIED:		APVD	P deJONG	18MAR86
0 PLC	± -	PRODUCT SPEC	108-25,016	
1 PLC	± -	APPLICATION SPEC	114-25,004	
2 PLC	± -	WEIGHT	-	
3 PLC	± .005	SIZE	A2	00779
4 PLC	± -	CAGE CODE	C=87986	
ANGLES	± -	DRAWING NO	87986	
MATERIAL: HOUSING - FLAME RETARDANT THERMOPLASTIC, COLOR - BLACK	FINISH: .000030 GOLD IN THE CONTACT AREA, GOLD FLASH ON THE REMAINDER, ALL OVER .000050 NICKEL	SCALE	5:1	
CONTACTS - PHOS BRONZE		SHEET	1 OF 1	
		REV	L1	