

REVISIONS				
P	LTN	DESCRIPTION	DATE	APVD
I		INITIAL RELEASE	25AUG22	SM WW
A		ECN-22-187765	02DEC2022	SM FL
A1		ECR-23-191968	21NOV2023	SM FL

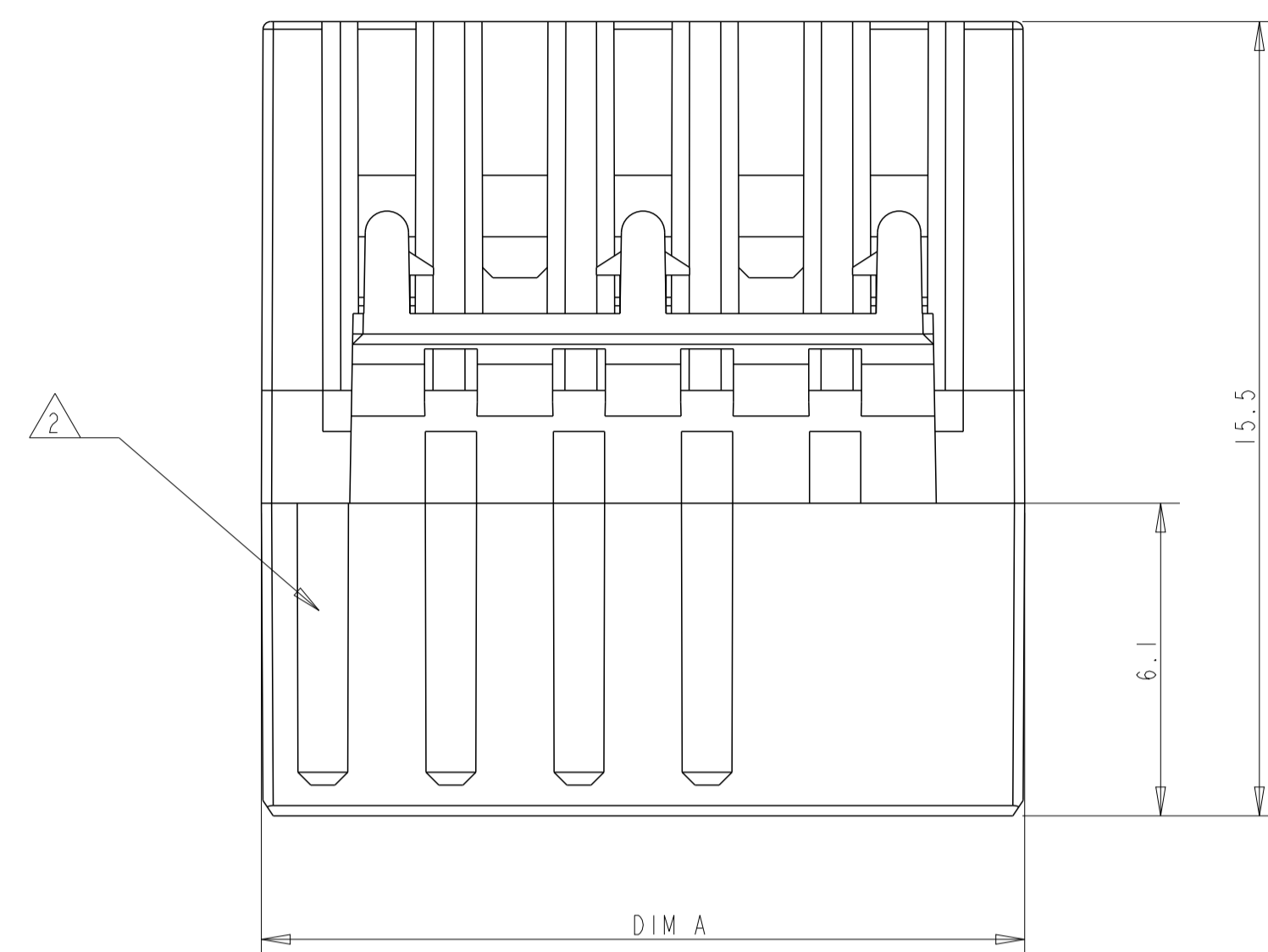

- 1 MATERIAL: PA UL94-V0 GWT 750°C NF
- 2 KEYING RIB
- 3 CONTACT CAVITY NO.
- 4 AREA FOR TE LOGO
- 5 PRELIMINARY PART- THIS PRODUCT HAS NOT COMPLETED QUALITICATION TESTING
- 6 DESIGNATED FOR USE WITH CONTACT P/N 2391430-2

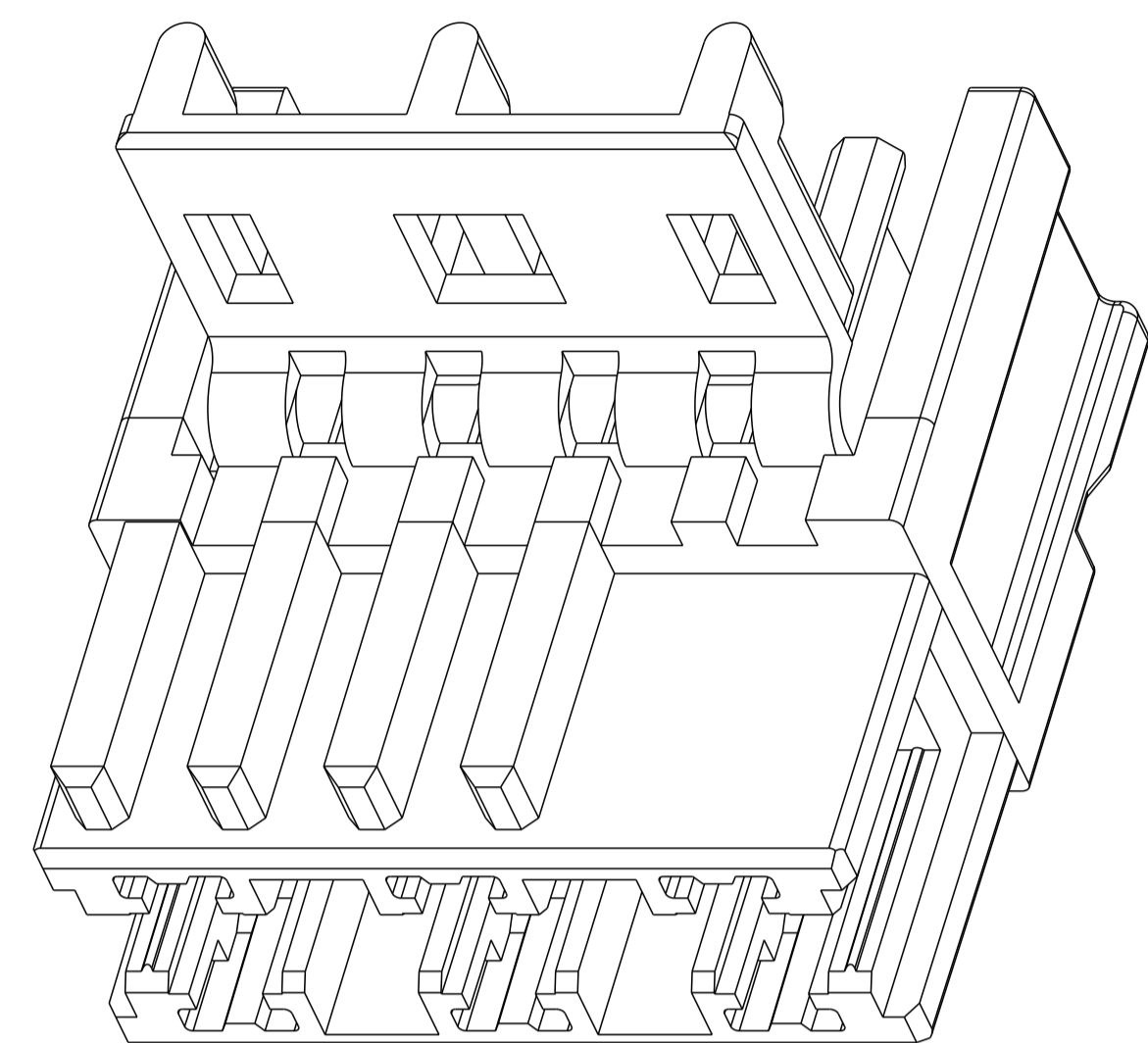
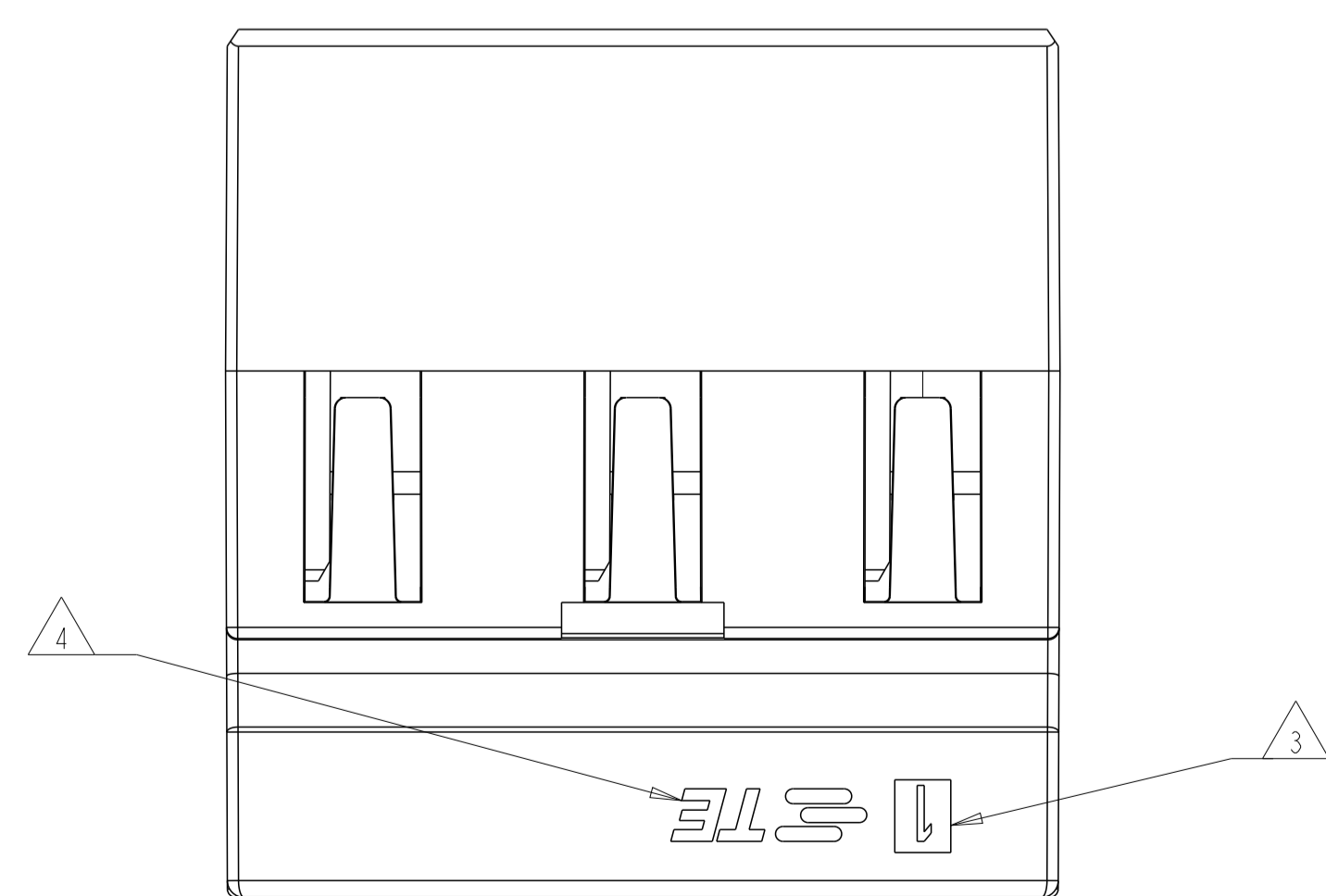
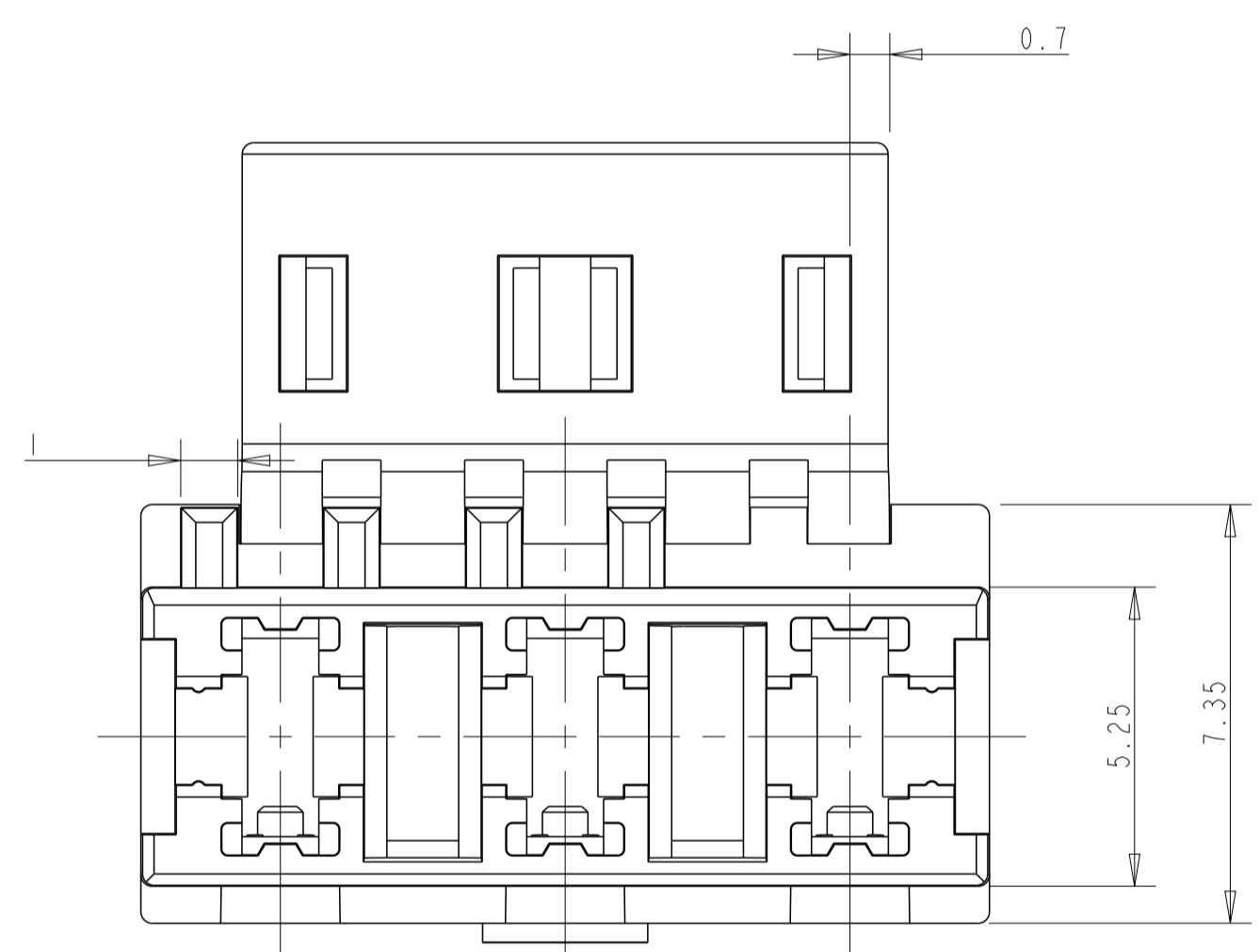
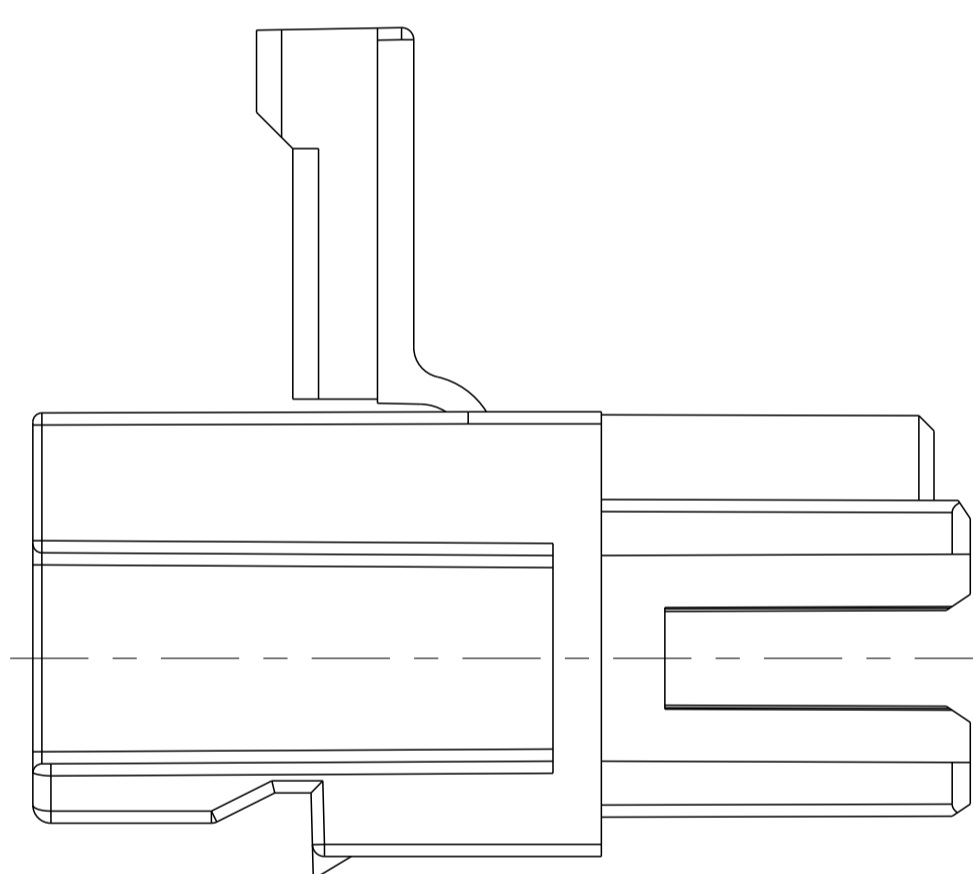

NATURAL	24.9	5	2404460-5
	14.9	3	2404460-3
COLOR	DIM A	POS.	PART NO.

THIS DRAWING IS A CONTROLLED DOCUMENT.		DWN: SUBHASH M 25AUG2022	TE Connectivity	
DIMENSIONS: mm		CHK: WINTER WANG 25AUG2022		
TOLERANCES UNLESS OTHERWISE SPECIFIED:		APVD: F. LUPO 25AUG2022		
0 PLC	±	PRODUCT SPEC	NAME: HSG, RAST 2.5 STD TIMER	
1 PLC	±0.2	108-160359	SIZE: A	
2 PLC	±0.2	APPLICATION SPEC	CAGE CODE: 00779	
3 PLC	±	114-160192	DRAWING NO: 2404460	
4 PLC	±	WEIGHT	RESTRICTED TO: -	
ANGLES	±	CUSTOMER DRAWING	SCALE: 8:1	
FINISH	-		SHEET 1 OF 2	
			REV: A3	

REVISIONS				
P	LTN	DESCRIPTION	DATE	APVD
		SEE SHEET 1		

KEYING PLAN

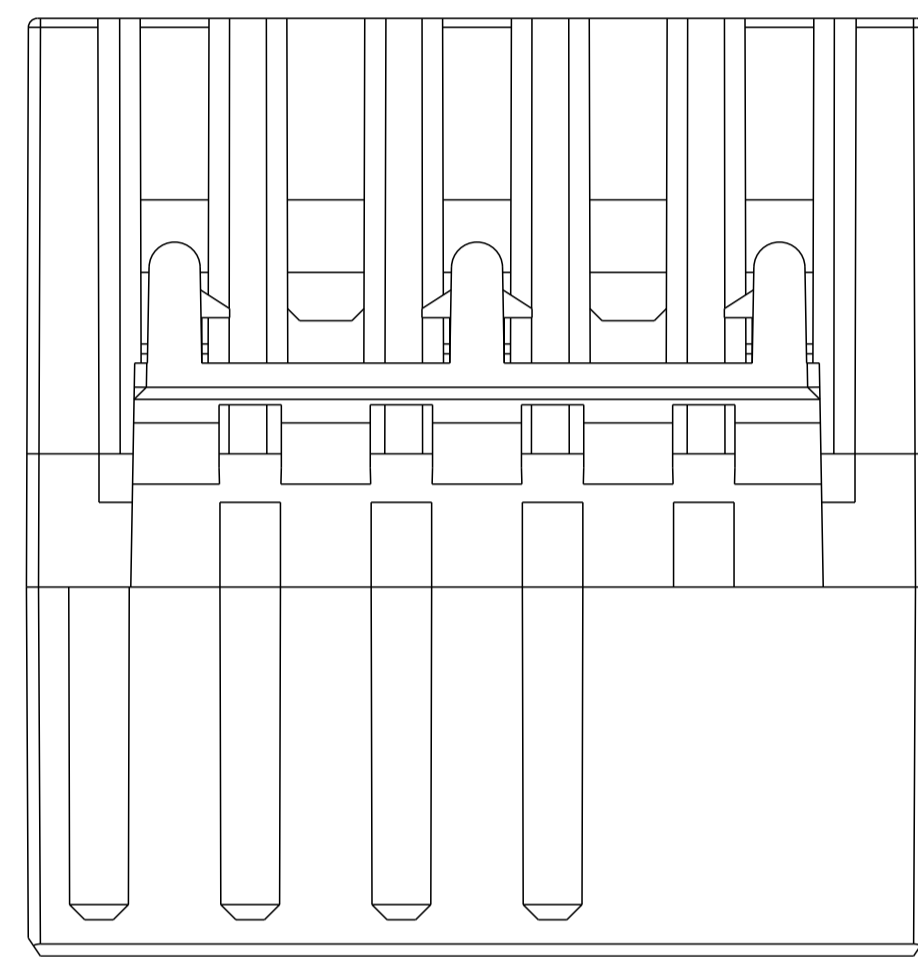

2404460-3

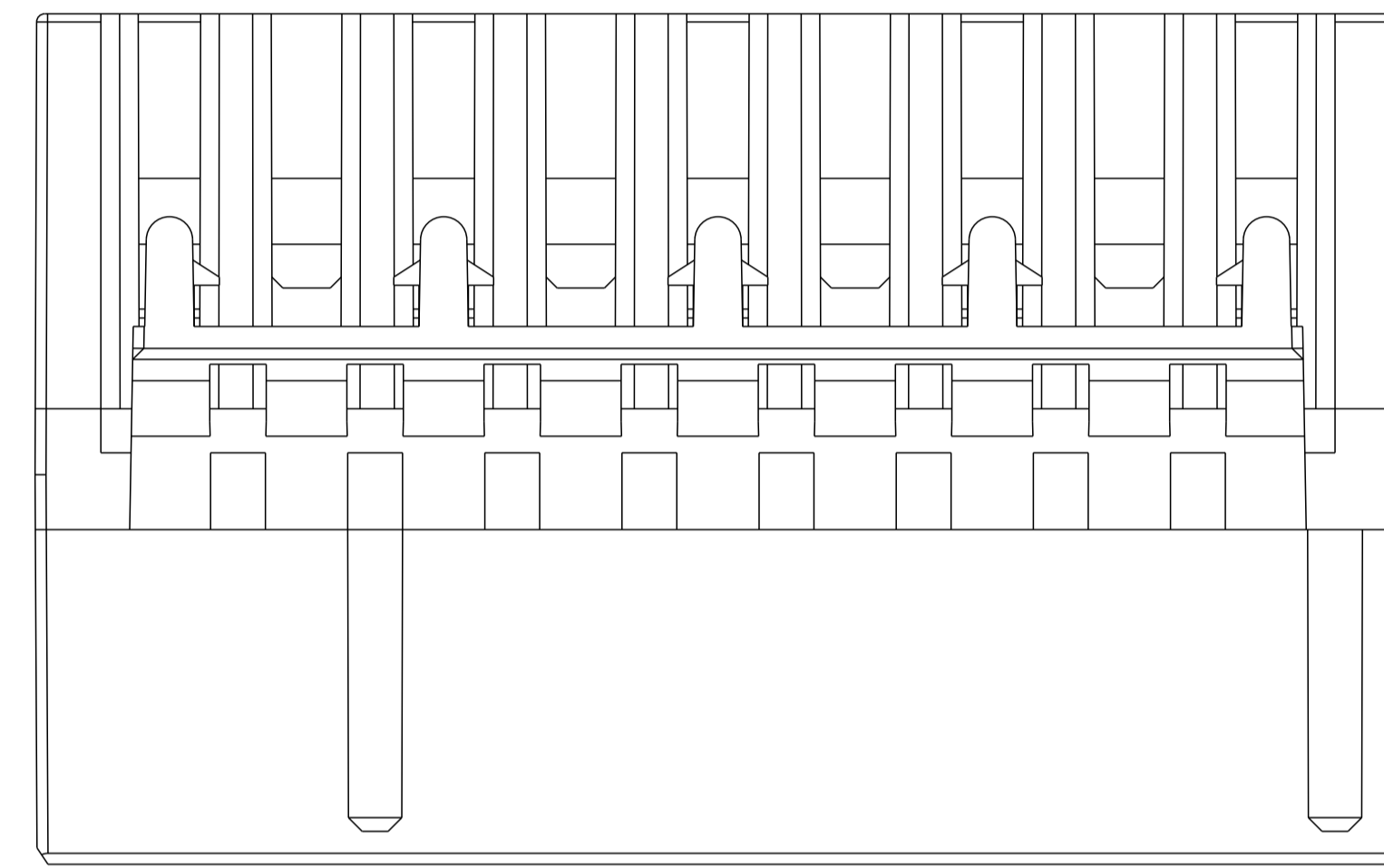

2404460-5

THIS DRAWING IS A CONTROLLED DOCUMENT.		DWN SUBHASH M 25AUG2022 CHK WINTER WANG 25AUG2022 APVD F. LUPO 25AUG2022		
DIMENSIONS: mm	TOLERANCES UNLESS OTHERWISE SPECIFIED: 0 PLC ± 1 PLC ±0.2 2 PLC ±0.2 3 PLC ± 4 PLC ± ANGLES ± FINISH	NAME HSG PRODUCT SPEC RAST 2.5 STD TIMER APPLICATION SPEC - SIZE 114-160192 WEIGHT - MATERIAL -	CAGE CODE 00779 DRAWING NO. 2404460	RESTRICTED TO - SCALE 8:1 SHEET 2 OF 2 REV A3
		CUSTOMER DRAWING		