

P	LTR	REVISIONS ÄNDERUNGEN DESCRIPTION BESCHREIBUNG	DATE	DWN	APVD
A3		NEW VERSION ADDED SEE PCN E-13-010548 TE CONNECTIVITY LOGO DESIGN CHANGED	01JUL2013	NP	FE
B		PART CHANGED SEE PCN E-20-009598 Teil wurde geändert siehe PCN E-20-009598	09JUN2020	NP	GL
B1		SEE PCN-22-150886 Siehe PCN-22-150886	19AUG2022	SN	AW
B2		SEE PCN-26-268188 Siehe PCN-26-268188	20JAN2026	NP	AW

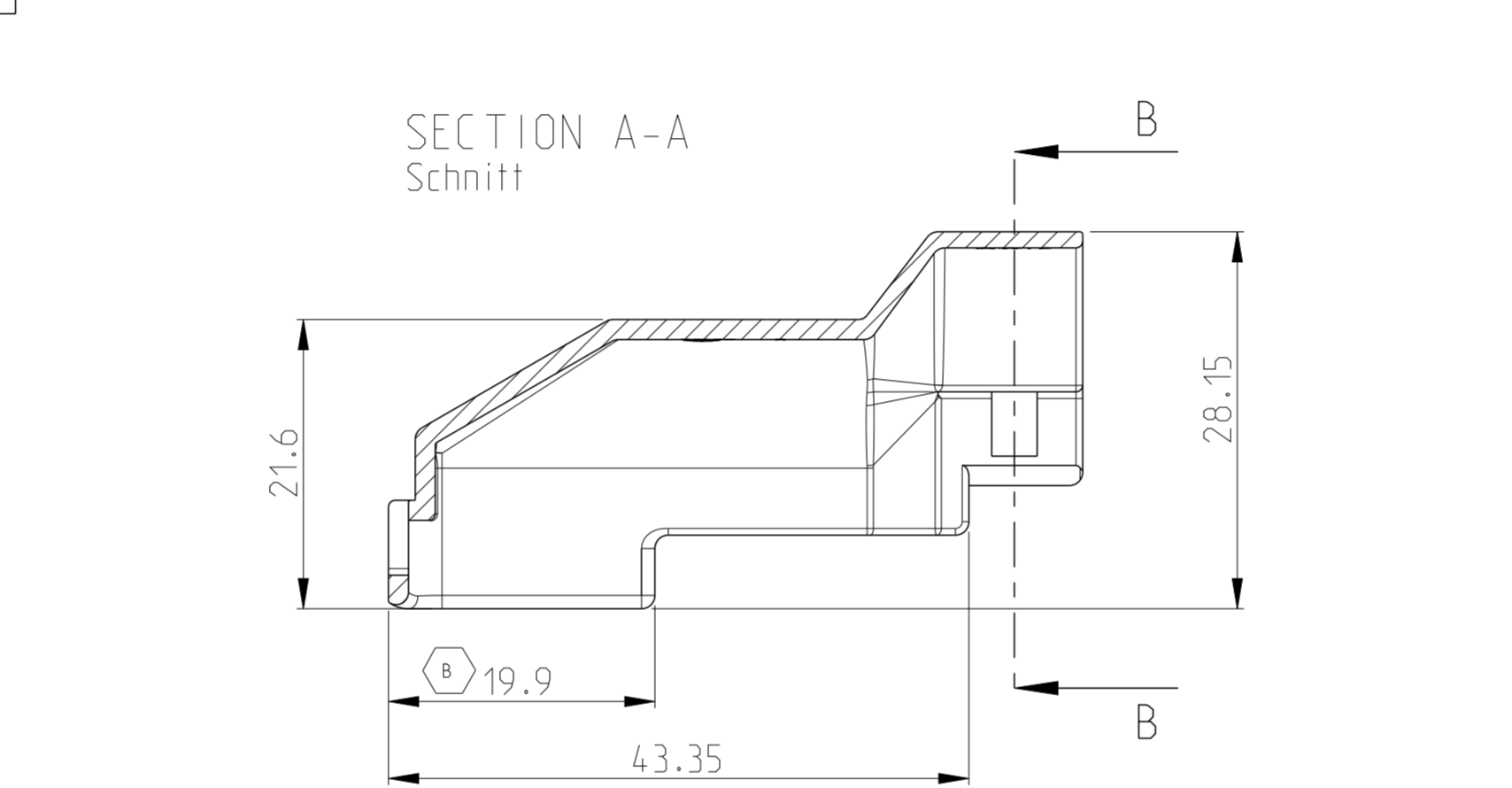

- NOTES
Bemerkungen
- 1 TE CONNECTIVITY PRODUCT IDENTIFIER.
TE Connectivity Warenzeichen.
 - 2 TE PART NO.
TE Teilenummer.
 - 3 PRODUCTION DATE.
Produktionsdatum.
 - 4 REVISION STATUS OF THE MOULD.
Änderungsstand des Werkzeugs.
 - 5 MOULD CAVITY MARKING (ONLY IF > 1 CAVITY).
Nestmarkierung (nur bei mehrstrigem Werkzeug).
 - 6 MATERIAL MARKING ACC. TO VDA 260.
Werkstoffkennzeichnung nach VDA 260.
 - 7 WARPAGE TO -2.0 FROM NOMINAL DIMENSION PERMITTED.
Verzug bis -2.0 vom Nennmass zulaessig.
 - 8 BULK PACKAGING IN CORRUGATED SHIPPING BOX.
Schuetttgut in Versandkarton.
 - 9 DESIGNED FOR CORRUGATED TUBE WITH NOMINAL WIDTH NW17.
vorgesehen fuer Wellrohr der Nennweite NW17.
 - B2 10 POSSIBLE ALTERNATE MATERIAL PA6-GF30 OR PA66-GF30 WILL BE SHOWN ON MATERIAL MARKING.
Mögliches alternatives Material PA6-GF30 oder PA66-GF30 wird mit der Werkstoffkennzeichnung angezeigt.

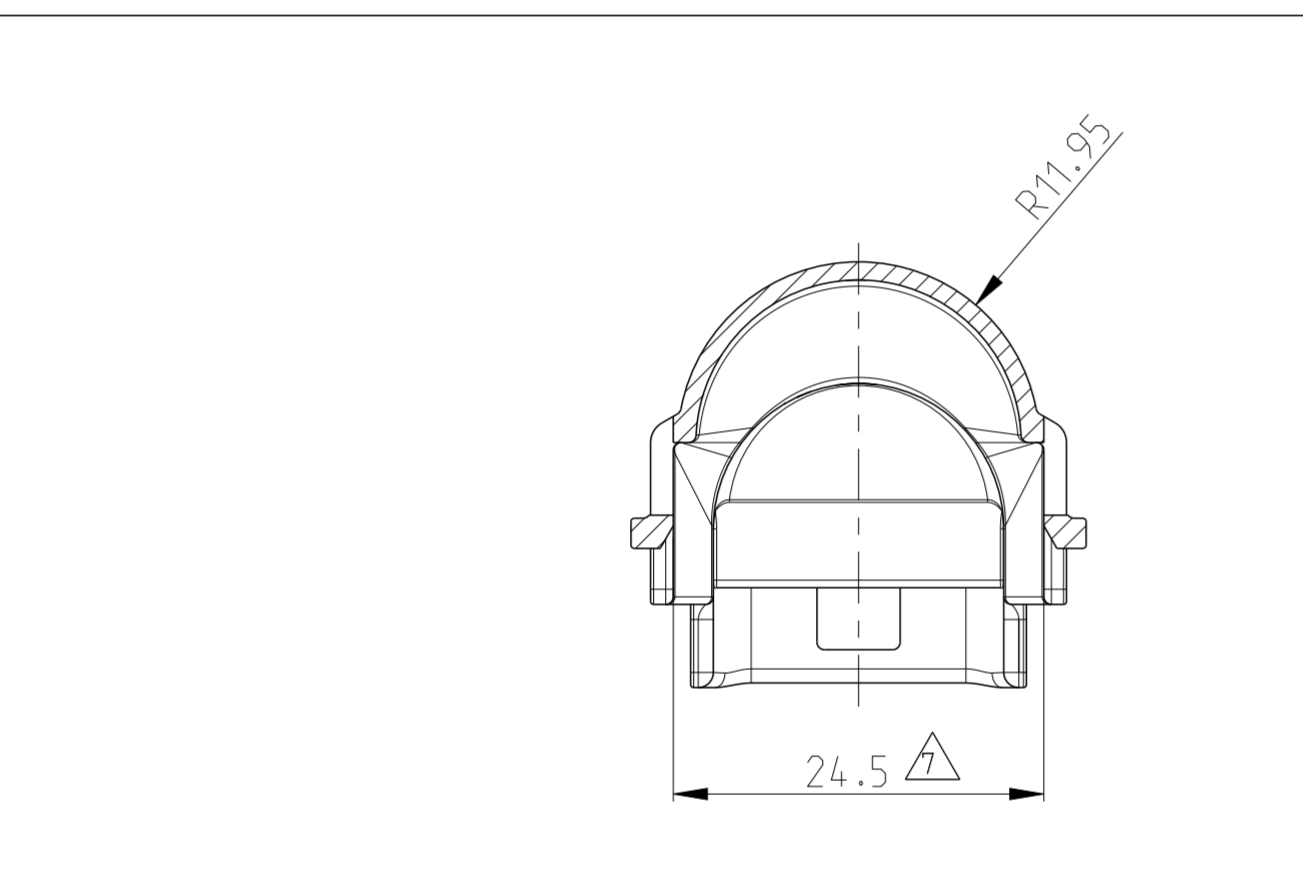
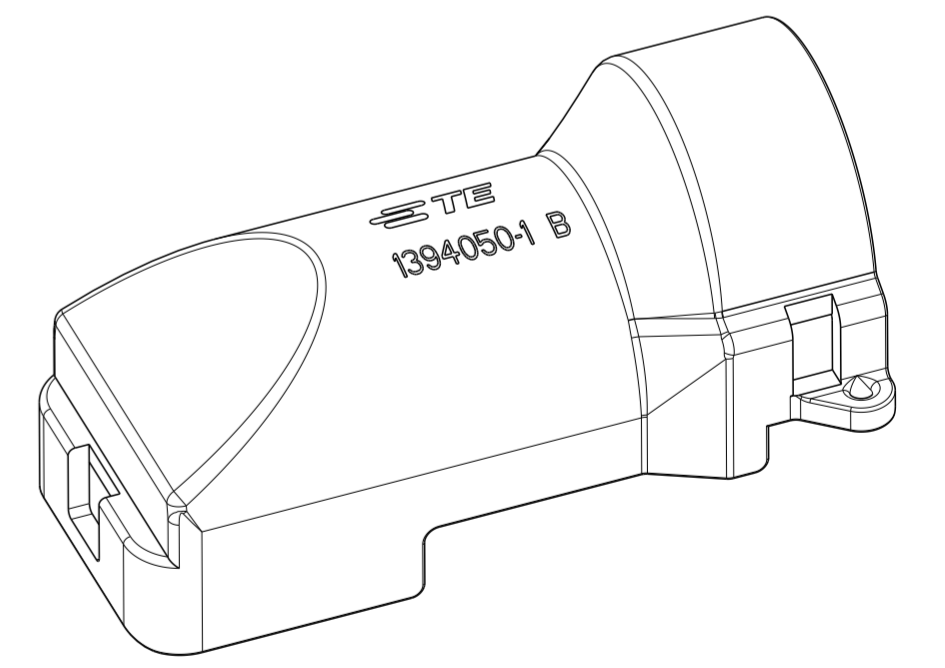
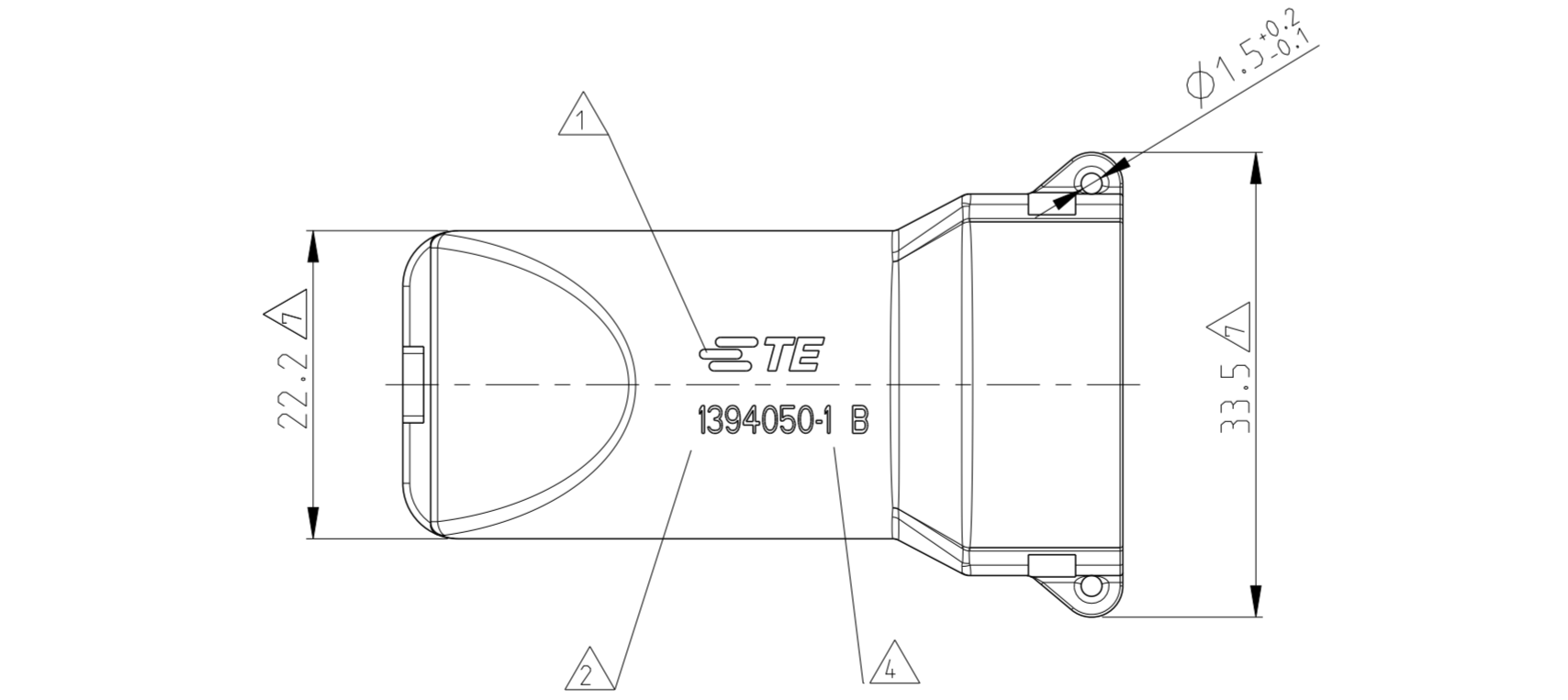
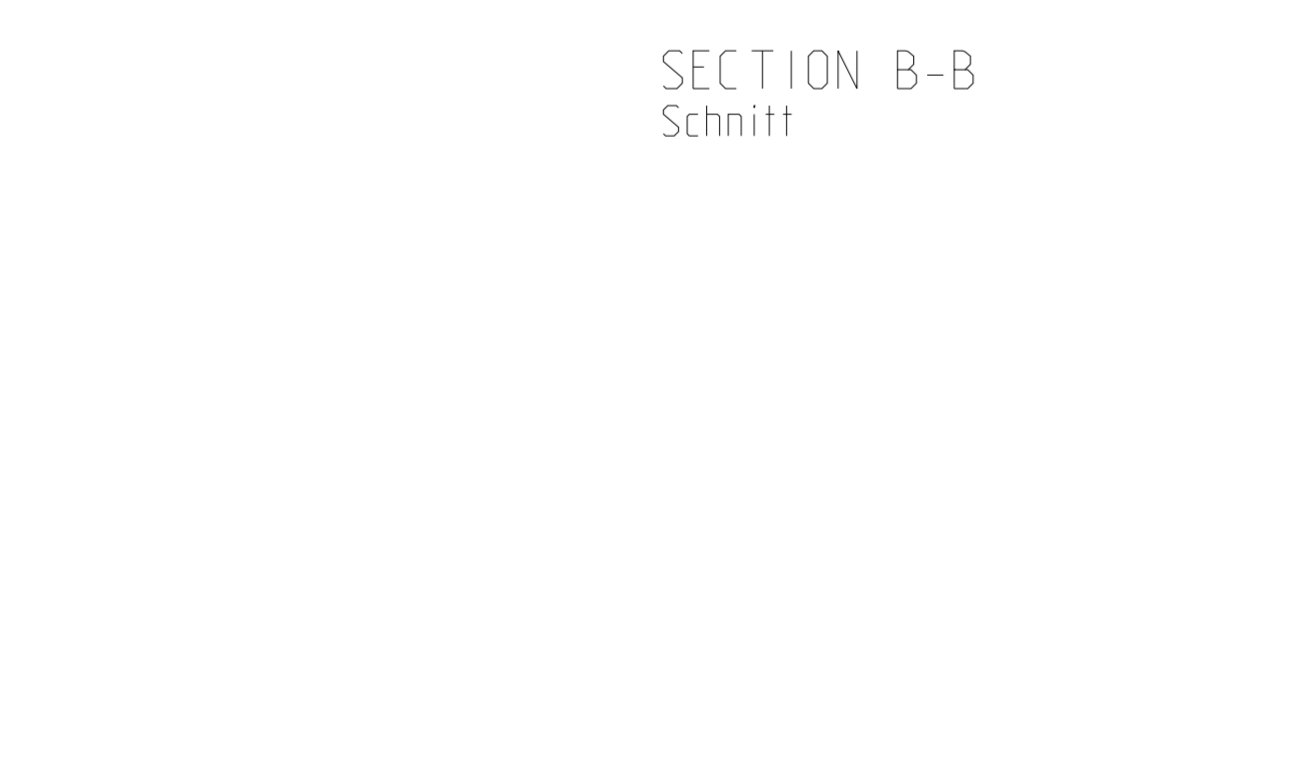

TE ORDER-NO. TE Bestell-Nr.	REV.	MAT.	COLOUR Farbe	DESCRIPTION Beschreibung	ITEM
0-1394050-2	B	PA66-GF20	BLACK schwarz	COVER Abdeckkappe	2
9-1394050-1	B	PA66-GF20	BLACK schwarz	COVER Abdeckkappe	1

DIMENSIONS: MASSE INH EINEN: [mm]		TOLERANCES UNLESS OTHERWISE SPECIFIED: ALLGEMEINTOLERANZEN	
1 PLC	±	DIN16901	-14.0
2 PLC	±		
3 PLC	±		
4 PLC	±		
ANGLES/WINKEL		± 2°	
FINISH/OBERFLAECHE/FARBE			

MATERIAL: SEE PARTS LIST

OTHER INFORMATION: SEE PARTS LIST

THIS DRAWING IS A CONTROLLED DOCUMENT. DIESES ZEICHNUNGSDOKUMENT WIRD DURCH AMP INCORPORATED KONTROLLIERT. ÄNDERUNGEN, DIE DEM TECHNISCHEN FORTSCHRITT GEMEIN, SIND VORBEHALTEN. DEN JEWEILS LETZTIGELTEN ÄNDERUNGSSTAND ERFAHREN SIE AUF ANFRAGE.		DWN R. Huebner	05-NOV-01		TE Connectivity	
CHK J. Granzow	06-NOV-01	APVD J. Hass	01-DEC-01		NAME COVER FOR SOCKET HOUSING, 21POS. Abdeckkappe fuer Buchsenhaeuse, 21polig	
PRODUCT SPEC 108-18696		APPLICATION SPEC 114-18376		SIZE A2	CAGE CODE	DRAWING NO ZEICHNUNGS-NR. C-1394050
WEIGHT GEWICHT 4.9g		CUSTOMER DRAWING		SCALE MASSSTAB 2:1	SHEET BLATT 1 OF 1	RESTRICTED TO NUR FUER -