

THIS DRAWING IS UNPUBLISHED. RELEASED FOR PUBLICATION 20  
 © COPYRIGHT 20 BY - ALL RIGHTS RESERVED.

ITEM	DESCRIPTION	MATERIAL	OTHERS
1	FEMALE CONTACT	COPPER ALLOY	GOLD PLATED
2	HOUSING	NYLON	BLACK
3	COUPLING NUT	ZAMAK	NICKEL PLATED
4	OVER-MOLDING	PVC/TPU	BLACK
5	SHIELDED SHELL	COPPER ALLOY	NICKEL PLATED
6	O-RING	SILICONE	GRAY
7	CABLE	PVC/PUR JACKET	GRAY/VIOLET
8	LABEL	-	-

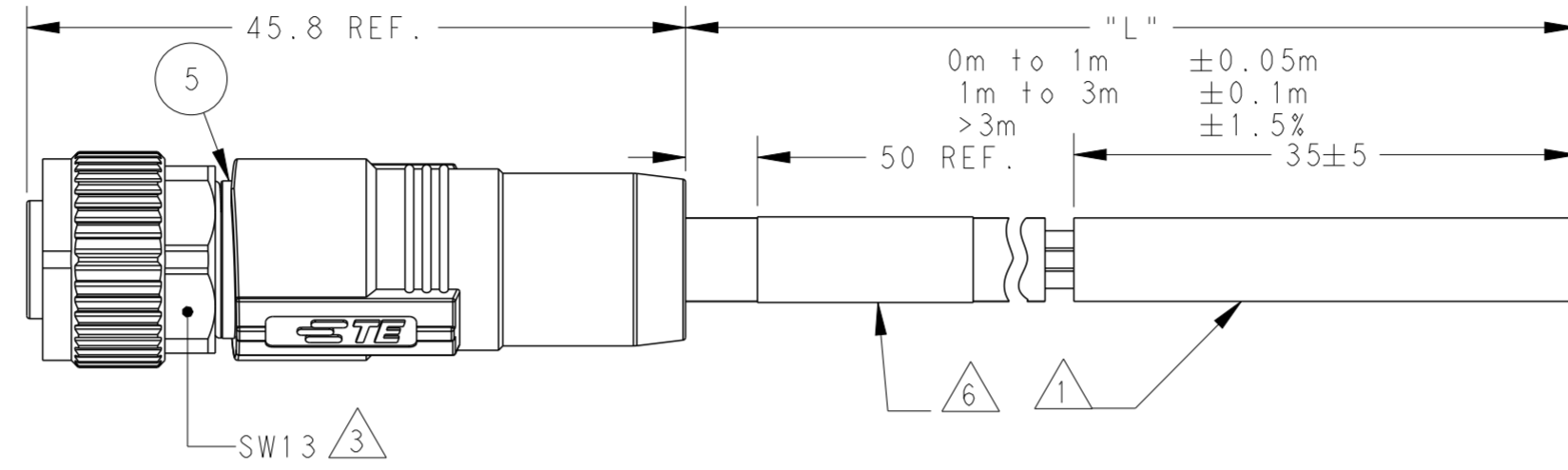
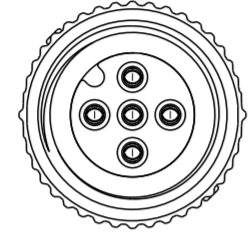

REVISIONS				
P	LTR	DESCRIPTION	DATE	APVD
A		INITIAL RELEASE	29JUL2019	A.Z C.W
A1		CLARIFY TYPICAL PNS	22JUN2020	A.Z C.W
B		ECR-22-134232	25JUN2025	B.P C.W

NOTE:  
 1. STRIP AND RETAIN THE INSULATION  
 2. CODE POSITION INDICATOR  
 3. RECOMMENDED TORQUE 0.6 Nm  
 4. -\*:CABLE LENGTH, FOR EXAMPLE: -0.5M  
 5. CABLE ASSEMBLY TO BE PACKAGED IN POLYBAGS  
 6. LABEL CONTAINS: PN, DATE CODE...

注释:  
 1. 剥线并保留护套绝缘层  
 2. CODE位置指示  
 3. 推荐扭矩0.6 Nm  
 4. -\*:线缆长度,例如:-0.5M  
 5. 线缆组件塑料袋包装  
 6. 标签包含: 产品编号, 日期代码...

TABLE 1 TECHNICAL DATA		TAA753A1611-XXX	TAA753A5501-XXX
RATED VOLTAGE	60V		
RATED IMPULSE VOLTAGE	1500V		
RATED CURRENT	4A		
POLLUTION DEGREE	3		
OVERVOLTAGE CATEGORY	II		
MATERIAL GROUP	II		
DEGREE OF PROTECTION	IP67		

TE PN CODING:

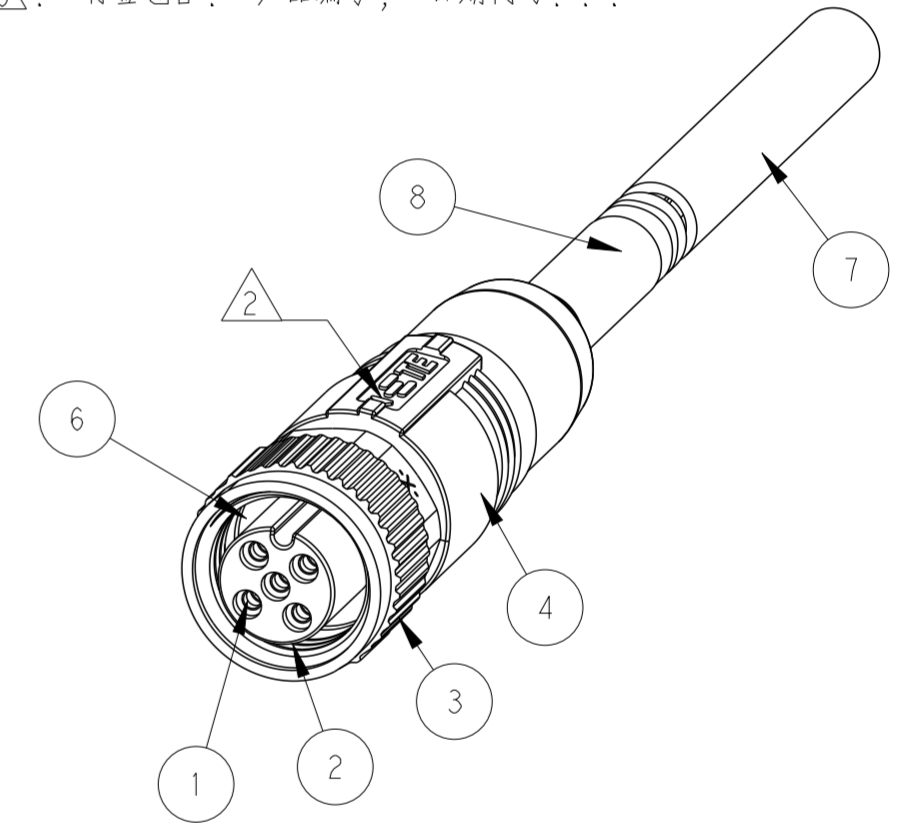
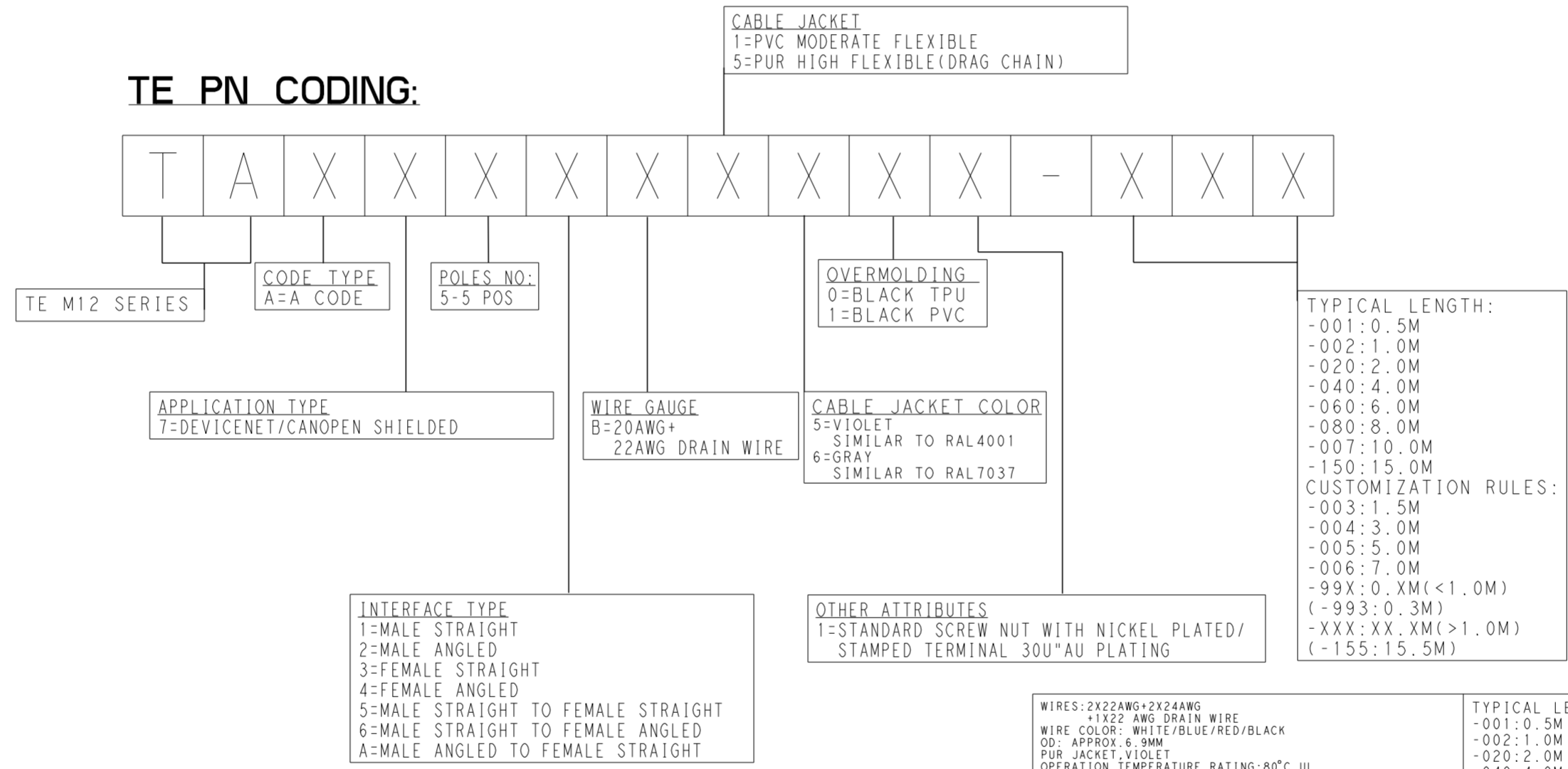

PIN ARRANGEMENT A-CODE	
PIN 4	CAN_H WHITE
PIN 5	CAN_L BLUE
PIN 1	DRAIN BARE
PIN 3	V- BLACK
PIN 2	V+ RED

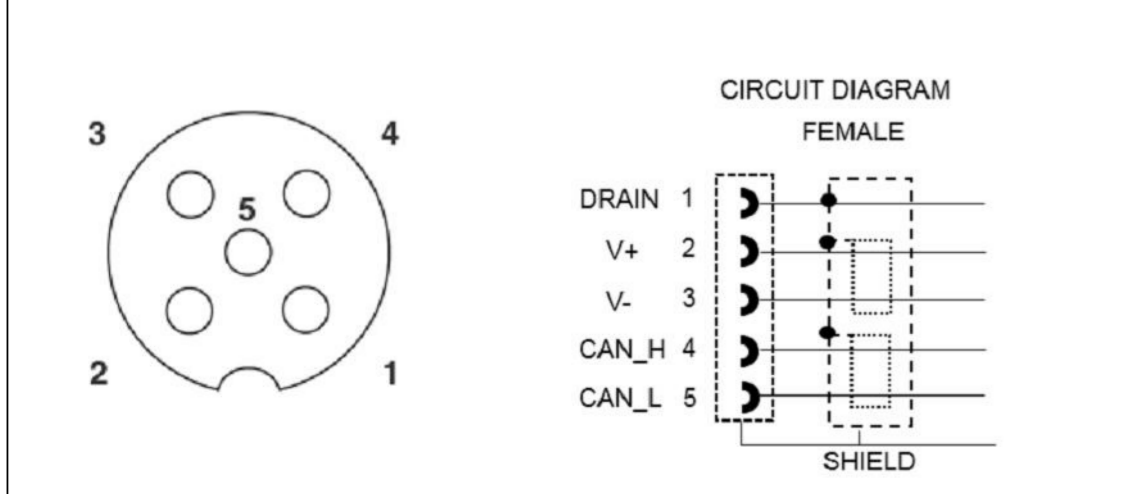

CABLE CHARACTERISTIC	LENGTH "L"	TYPE	TABLE 2 TE PN
WIRES: 2X22AWG+2X24AWG +1X22 AWG DRAIN WIRE WIRE COLOR: WHITE/BLUE/RED/BLACK OD: APPROX: 6.9MM PUR JACKET: VIOLET OPERATION TEMPERATURE RATING: 80°C UL OPERATION TEMP RATING: -40°C to +80°C DRAG CHAIN TEST: MIN: 0.5 MILLION CYCLES, DIAMETER 75MM, SPEED 2m/s, ACCELERATION 2m/s <sup>2</sup>	TYPICAL LENGTH: -001: 0.5M -002: 1.0M -020: 2.0M -040: 4.0M -060: 6.0M -080: 8.0M -007: 10.0M -150: 15.0M CUSTOMIZATION RULES: -003: 1.5M -004: 3.0M -005: 5.0M -006: 7.0M -99X: 0.XM (<1.0M) (-993: 0.3M) -XXX: XX.XM (>1.0M) (-155: 15.5M)	M12A5-FS-PUR-**4	TAA753A5501-XXX
WIRES: 2X22AWG+2X24AWG +1X22 AWG DRAIN WIRE WIRE COLOR: WHITE/BLUE/RED/BLACK OD: APPROX: 7.1MM TEMPERATURE RATING: 75°C UL OPERATION TEMP RATING: -10°C to +80°C	TYPICAL LENGTH: -001: 0.5M -002: 1.0M -020: 2.0M -040: 4.0M -060: 6.0M -080: 8.0M -007: 10.0M -150: 15.0M CUSTOMIZATION RULES: -003: 1.5M -004: 3.0M -005: 5.0M -006: 7.0M -99X: 0.XM (<1.0M) (-993: 0.3M) -XXX: XX.XM (>1.0M) (-155: 15.5M)	M12A5-FS-PVC-**4	TAA753A1611-XXX

THIS DRAWING IS A CONTROLLED DOCUMENT.

DIMENSIONS: mm	TOLERANCES UNLESS OTHERWISE SPECIFIED:	DWN: ALEX ZHANG 11APR2019	CHK: HART HE 11APR2019	APVD: CHRIS WANG 11APR2019
MATERIAL: -	FINISH: -	PRODUCT SPEC: 108-106140	APPLICATION SPEC: 114-137144	WEIGHT: -
RESTRICTED CUSTOMER		SIZE: A2	CAGE CODE: -	DRAWING NO: G-TAA753AXXXXXXX
RESTRICTED TO		SCALE: 2:1	SHEET: 1 OF 1	REV: B

STE TE Connectivity  
 NAME: M12 A CODE CABLE ASSY, SHIELDED 5P, FS FREE END