



P	LTR	DESCRIPTION	DATE	DWN	APVD
	A1	REVISE PER ECN-25-329991	01JUL2025	ED	WZ

MATERIALS AND PLATING		UNIT: MICRO-INCHES
PART NAME	MATERIAL	PLATING
BODY/SHELL	BRASS	GOLD 3u"/NICKEL 100u"/COPPER 50u"
CONTACT PIN	Be-Cu C17300	SEE TEPN LIST
INSULATOR	PTFE ASTM-D-1710	N/A
GASKET	SILICONE(RED)	N/A
NUT	BRASS	GOLD 3u"/NICKEL 100u"/COPPER 50u"
WASHER	BRASS	GOLD 3u"/NICKEL 100u"/COPPER 50u"

ELECTRICAL CHARACTERISTICS	
IMPEDANCE	50 Ω
VOLTAGE RATING	330 V(rms)
FREQUENCY RANGE	DC~6 GHz
DIELECTRIC WITHSTANDING VOLTAGE	>1000 V
CONTACT RESISTANCE	CENTER CONTACT <3.0 mΩ
	OUTER CONTACT <2.0 mΩ
INSULATION RESISTANCE	>1000 MΩ
INSERTION LOSS	N/A
VSWR	<1.30
3RD INTERMODULATION	N/A

MECHANICAL CHARACTERISTICS	
DURABILITY	> 500 cycles

ENVIRONMENTAL PARAMETER	
TEMPERATURE RANGE	-65 °C~+165 °C
WATERPROOF	IP68 & INTERNALLY SEALED 
THERMAL SHOCK	MIL- STD 202, Meth. 107,Cond. B
VIBRATION	MIL- STD 202, Meth. 204,Cond. D
SHOCK	MIL- STD 202, Meth. 213,Cond. I
CORROSION	MIL- STD 202, Meth. 101,Cond. B

NOTES:
 1 TRAY AND BOX PACKAGING.PACKAGING DRAWING FOR 2502464-1&2502464-2 ARE IN P2;
 2 ALL DIMENSIONS ARE NOMINAL FOR REFERENCE ONLY UNLESS OTHERWISE STATED;
 3 RoHS: COMPLIANT;
 IT CAN MEET IP68 WATERPROOF IN BOTH MATING CONDITION AND UN-MATING CONDITION.

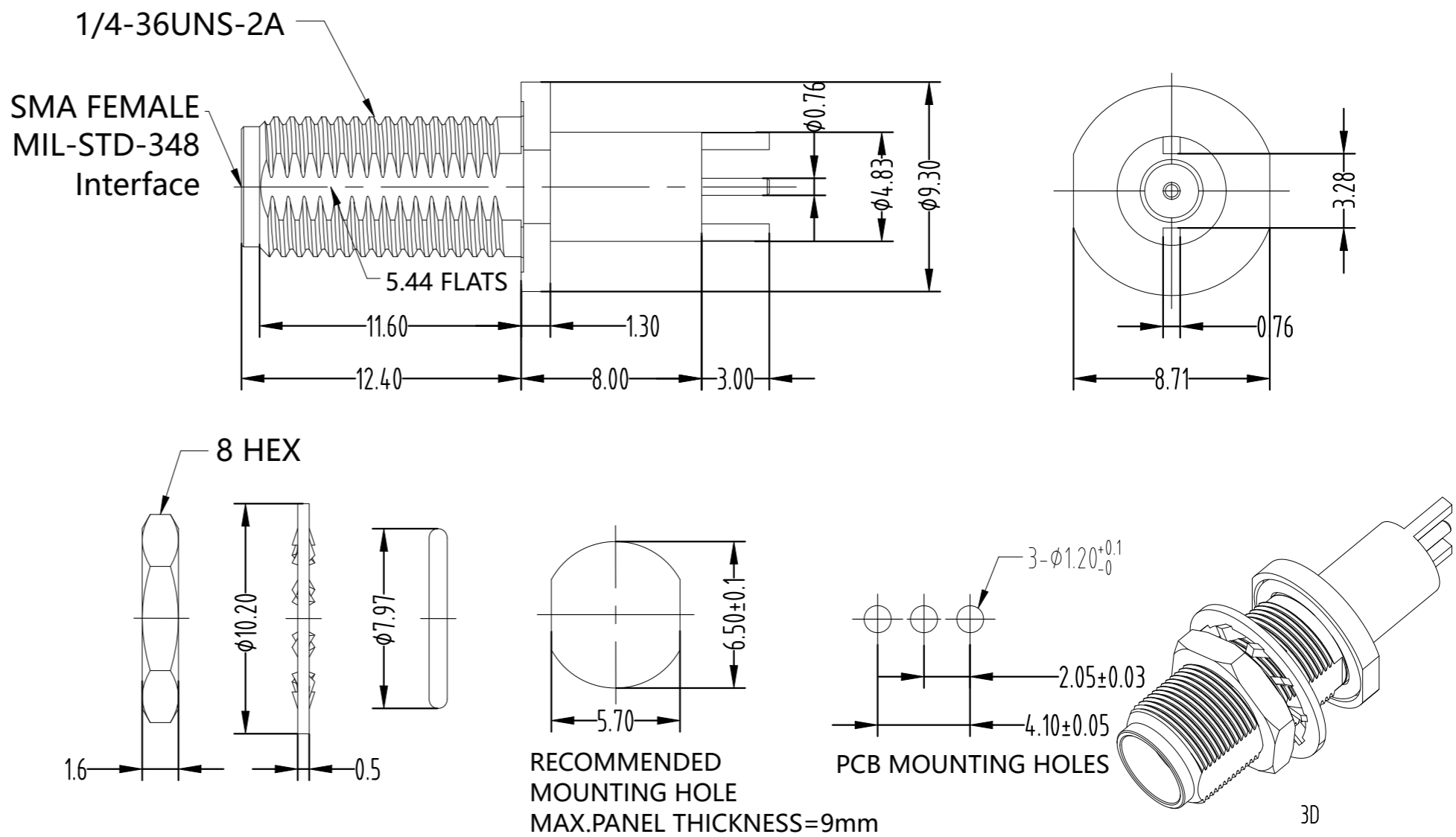

GOLD 30u"/NICKEL 100u"/COPPER 50u"	2502464-2
GOLD 10u"/NICKEL 100u"/COPPER 50u"	2502464-1
THE PLATING OF CONTACT PIN	PART NUMBER

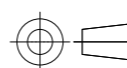
THIS DRAWING IS A CONTROLLED DOCUMENT.		DWN ED 10MAR2025	 TE Connectivity	
		CHK TP 10MAR2025		
DIMENSIONS: mm		APVD WH 10MAR2025	NAME SMA Jack St Bulkhead Thru Hole IP68	
		PRODUCT SPEC		SIZE
		APPLICATION SPEC		CAGE CODE
MATERIAL		WEIGHT		DRAWING NO
FINISH		CUSTOMER DRAWING		RESTRICTED TO
		SCALE 1:1		SHEET 1 OF 2
		REV A1		

REVISIONS					
P	LTR	DESCRIPTION	DATE	DWN	APVD
-	-	SEE SHEET 1	-	-	-

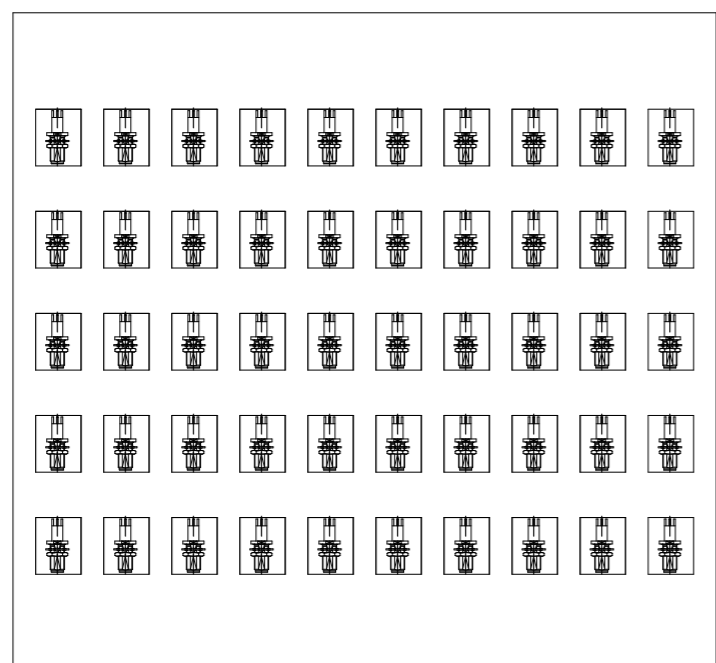
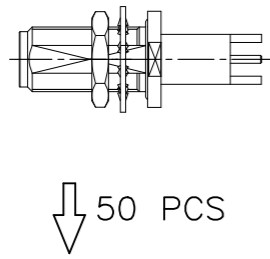

10 dish
→

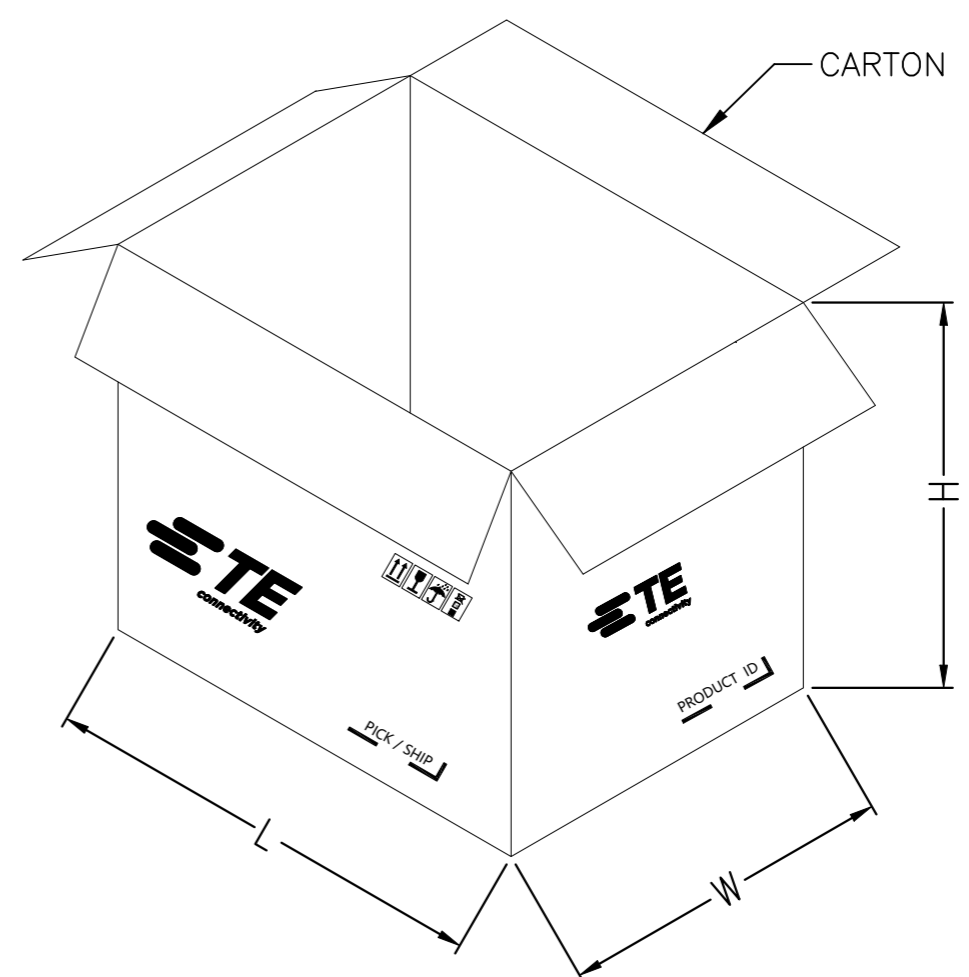

- NOTES :
- DIMENSION:
CARTON: L=330, W=320, H=180
 - QUANTITY:
 - PRIMARY PACKING: 50 PCS/DISH(50PCS)
 - OUTER PACKING: 10 DISH/CARTON(500PCS)

THIS DRAWING IS A CONTROLLED DOCUMENT.		DWN	ED	10MAR2025	STE TE Connectivity			
		CHK	TP	10MAR2025				
DIMENSIONS: mm		TOLERANCES UNLESS OTHERWISE SPECIFIED:			NAME			
		0 PLC	± -		SMA Jack St Bulkhead Thru Hole IP68			
		1 PLC	± 0.3					
		2 PLC	± 0.2					
		3 PLC	± 0.1					
		4 PLC	± -		PRODUCT SPEC			
		ANGLES	± 5°		APPLICATION SPEC			
MATERIAL		FINISH			SIZE	CAGE CODE	DRAWING NO	RESTRICTED TO
					—	A300779	C-2502464	—
CUSTOMER DRAWING					SCALE	1:1	SHEET	2 OF 2
					REV	A1		