

REVISIONS				
#	LTN	DESCRIPTION	DATE	APP'D
B		NEW CPA DESIGN	25APR2024	LSZ SZN
C		CPA DESIGN OPTIMIZATION	18OCT2024	LSZ SZN
C1		INTRODUCTION OF NEW VARIANT	18NOV2024	LSZ SZN
D		INTRODUCTION OF NEW VARIANT	18FEB2026	GYR SZN

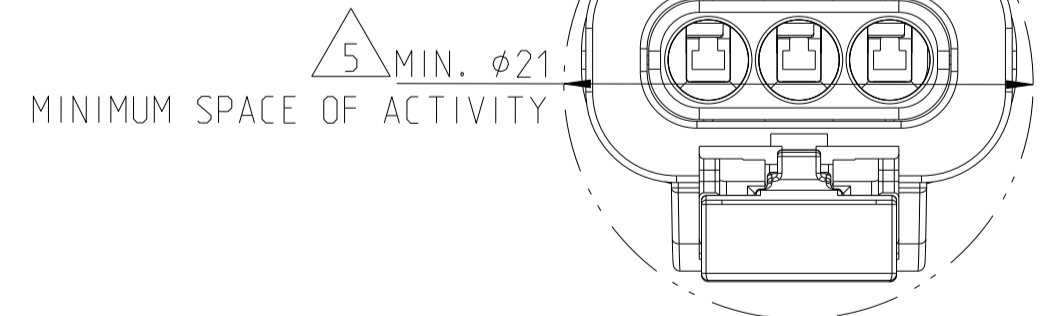

- NOTES:
- 1 AREA FOR LASER PRINT
 - 2 USABLE CONTACTS MCON 1.2 LL SEE TE-NO. 1452674
 - 3 SEE PRODUCT SPECIFICATION NO.108-18782 FOR THE FOLLOWING PRODUCT PROPERTIES:
 - MAX. WIRE SIZE RANGE PERMITTED
 - PERMISSIBLE CURRENT CARRYING CAPACITY OF THE SINGLE CONTACT
 - MAX OPERATING VOLTAGE
 - VIBRATION RESISTANCE
 - MAX OPERATING TEMPERATURE
 MAX OPERATING TEMPERATURE 130°C
 - 4 SUPPLIER-MARK (ONLY FOR TE CONNECTIVITY INTERNAL TRACKING)
 - 5 SPACE OF ACTIVITY
 - 6 SUPPLY CONDITION: CPA (4) AND RETAINER FLAP (1) IN PRELOCKED POSITION
 - 7 WARPAGE PERMITTED TO MAX. -0.5mm
 - 8 TE ORDER-NO.
 - 9 ACCORDING TO INTERFACE DRAWING SEE TE-NO. 114-18679-3
 - 10 ASSEMBLY LINE SEGMENT IDENTIFICATION
 - 11 DATE CODE (DDYY)
 - 12 DMC CODE:
 - FIRST ROW: MANUFACTURING INFORMATION ONLY FOR TE CONNECTIVITY
 - SECOND ROW: TE.COM ONLINE CATALOG LINK FOR CUSTOMER
 - 14 THE MARKING ON THE COMPONENTS MAY VARY IN THE SAME BATCH TOO IT DOES NOT SERVE ANY FUNCTION IT IS ONLY USED FOR TE CONNECTIVITY INTERNAL TRACKING FOR VALID CUSTOMER TRACKING PLEASE USE THE LASER PRINT - SEE NOTE 1
 - 15 PLEASE CARRY OUT THE CLEARANCE TEST FOR THE SOCKET HOUSING BASED ON THE WIRE SIZE USED
 - 16 SECONDARY LOCK THAT HAVE BEEN CLOSED DURING TRANSPORT CAN BE MOVED BACK TO PRE-LOCKED POSITION ACCORDING TO INSTRUCTIONS FOUND IN THE APPLICATION SPEC. NO 114-94767
 - 17 CONTACT TE SALES REPRESENTATIVE FOR ACTIVATION OF CROSSED OUT VERSIONS

QTY REQD PER ASSY	REVISION	DESCRIPTION	MATERIAL	COLOUR	ITEM NO
		3POS NEXTGEN MCON 1.2 LL CPA	PBT-GF30	RED	4
		3POS MCON 1.2 - SEAL	SILOPREN LSR	BLUE	3
		3POS, NEXTGEN MCON 1.2 - PROTEC. COVER	PA6-GF15	BLACK	2
		3POS NEXTGEN MCON 1.2LL REC HSG,SLD, - CODE D	PBT-GF20	VIOLET	1
		3POS NEXTGEN MCON 1.2LL REC HSG,SLD, - CODE C	PBT-GF20	BLUE	1
		3POS NEXTGEN MCON 1.2LL REC HSG,SLD, - CODE B	PBT-GF20	BROWN	1
		3POS NEXTGEN MCON 1.2LL REC HSG,SLD, - CODE A	PBT-GF20	BLACK	1

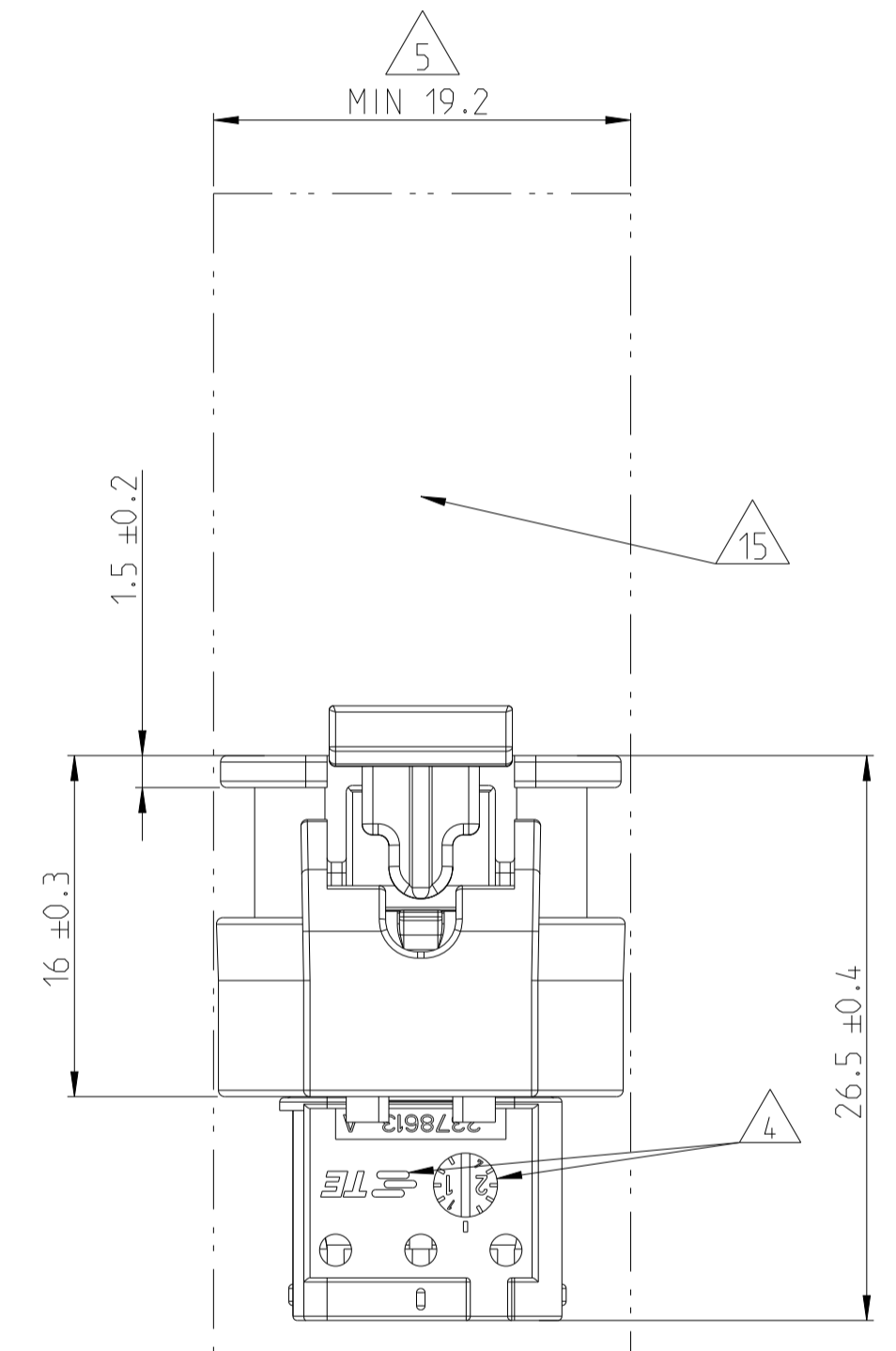
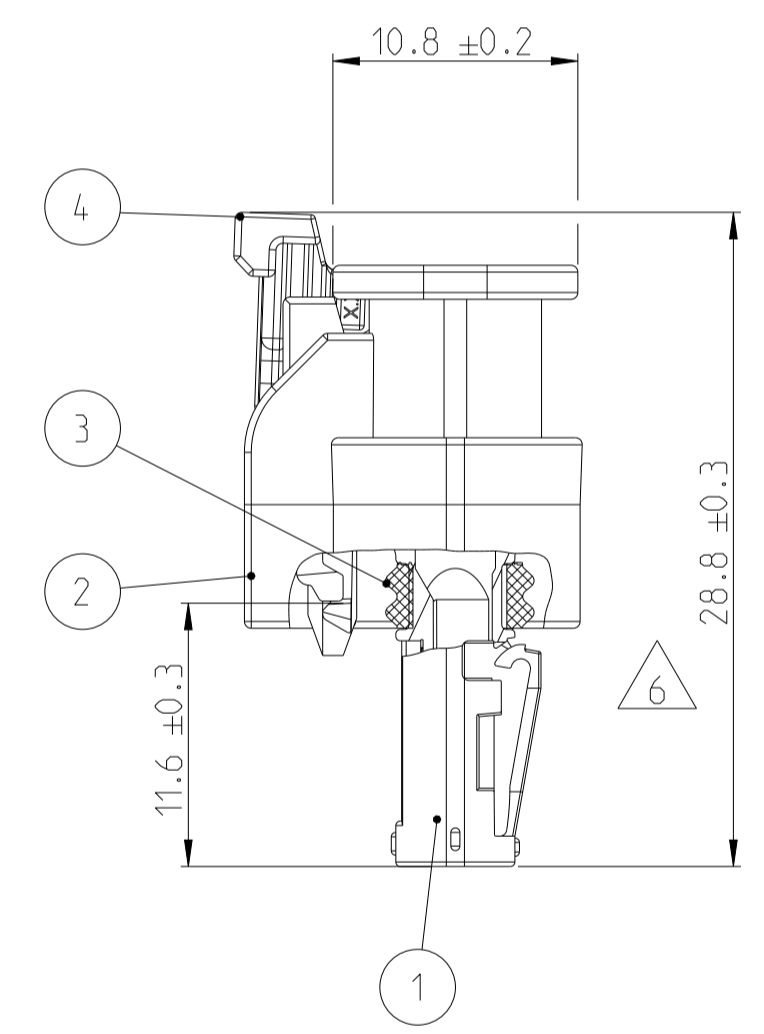
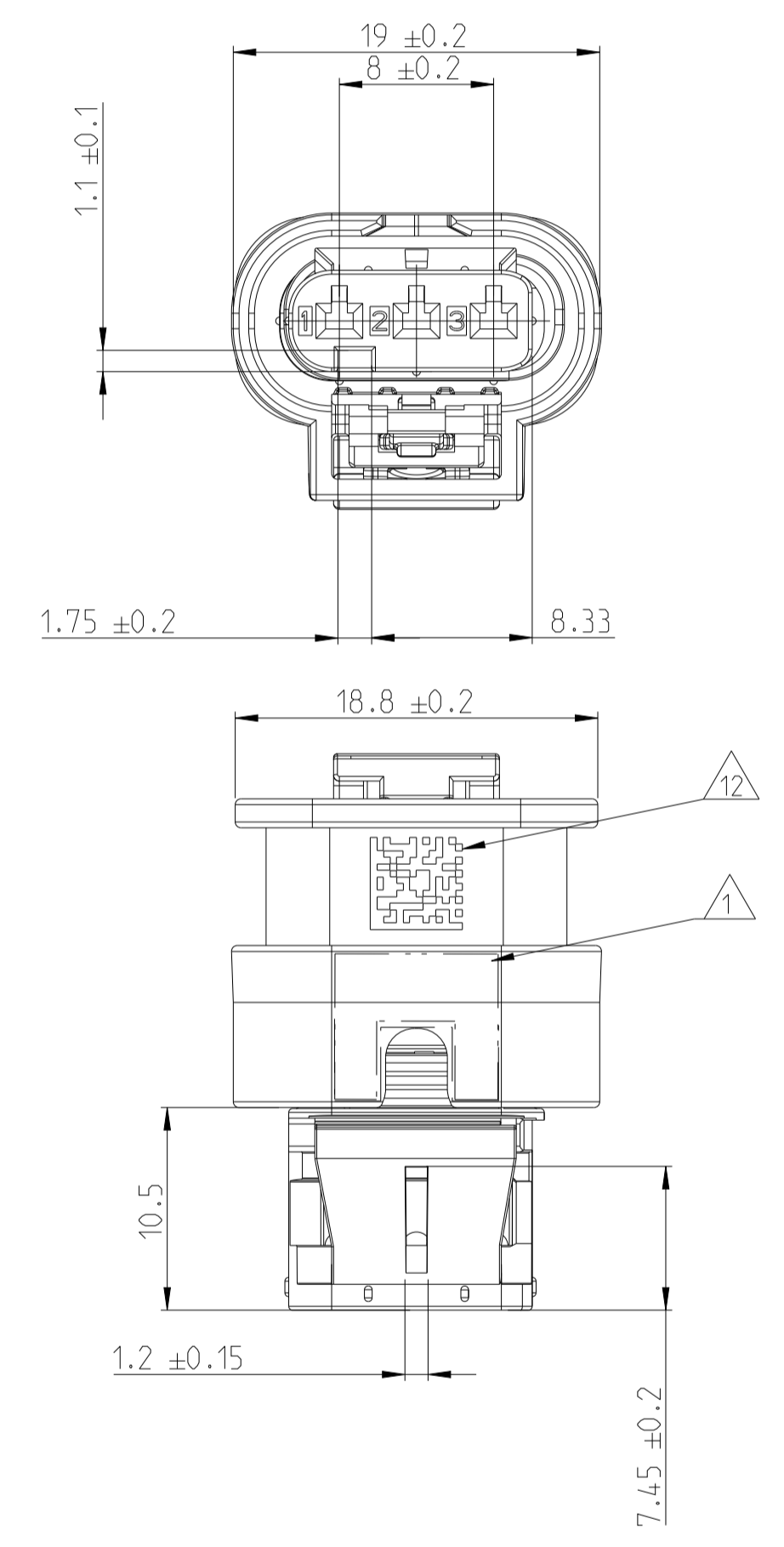
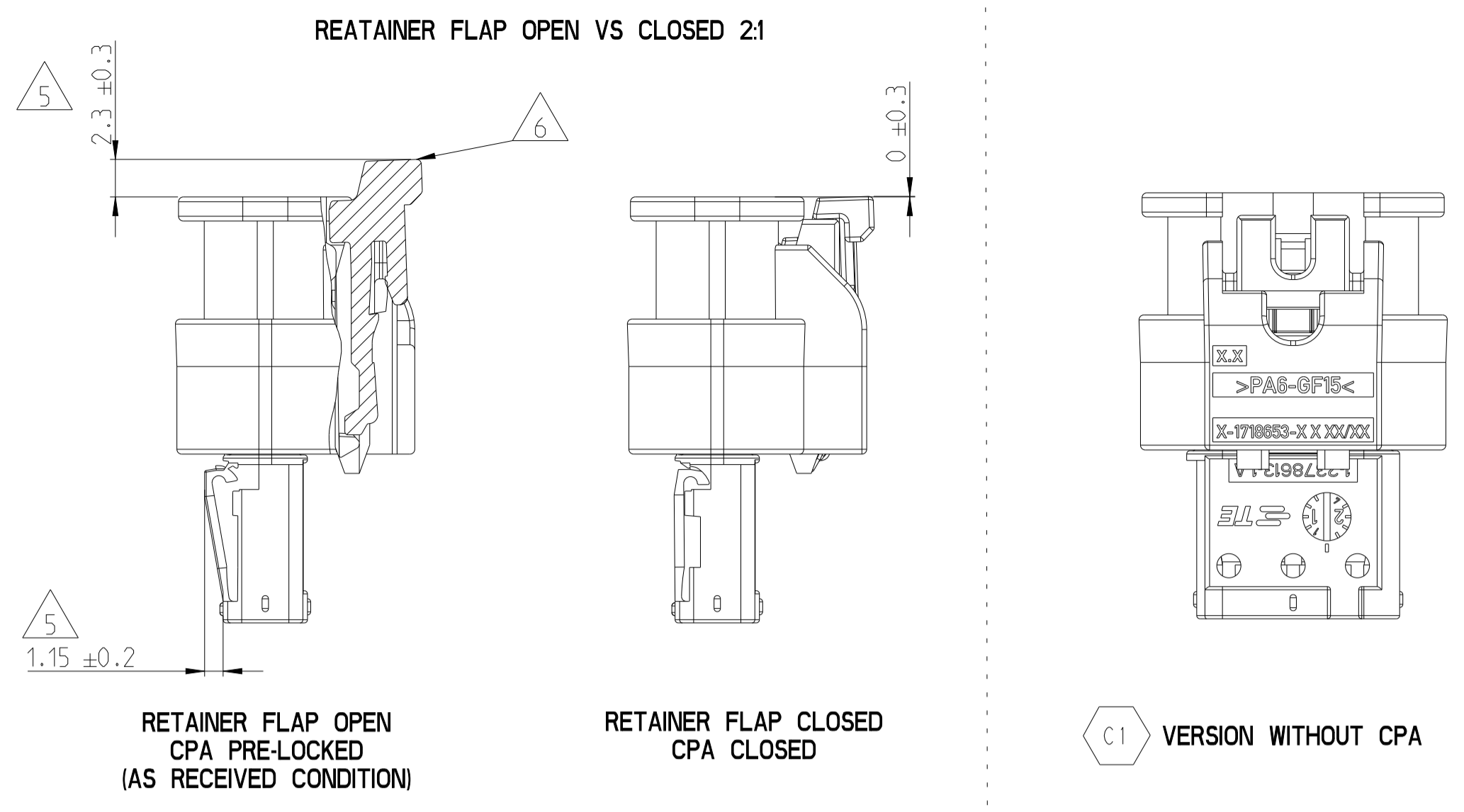
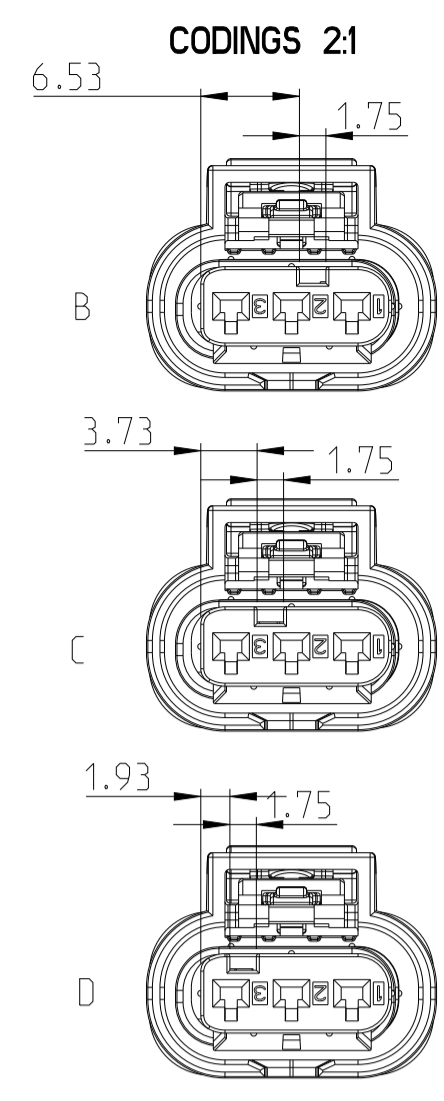
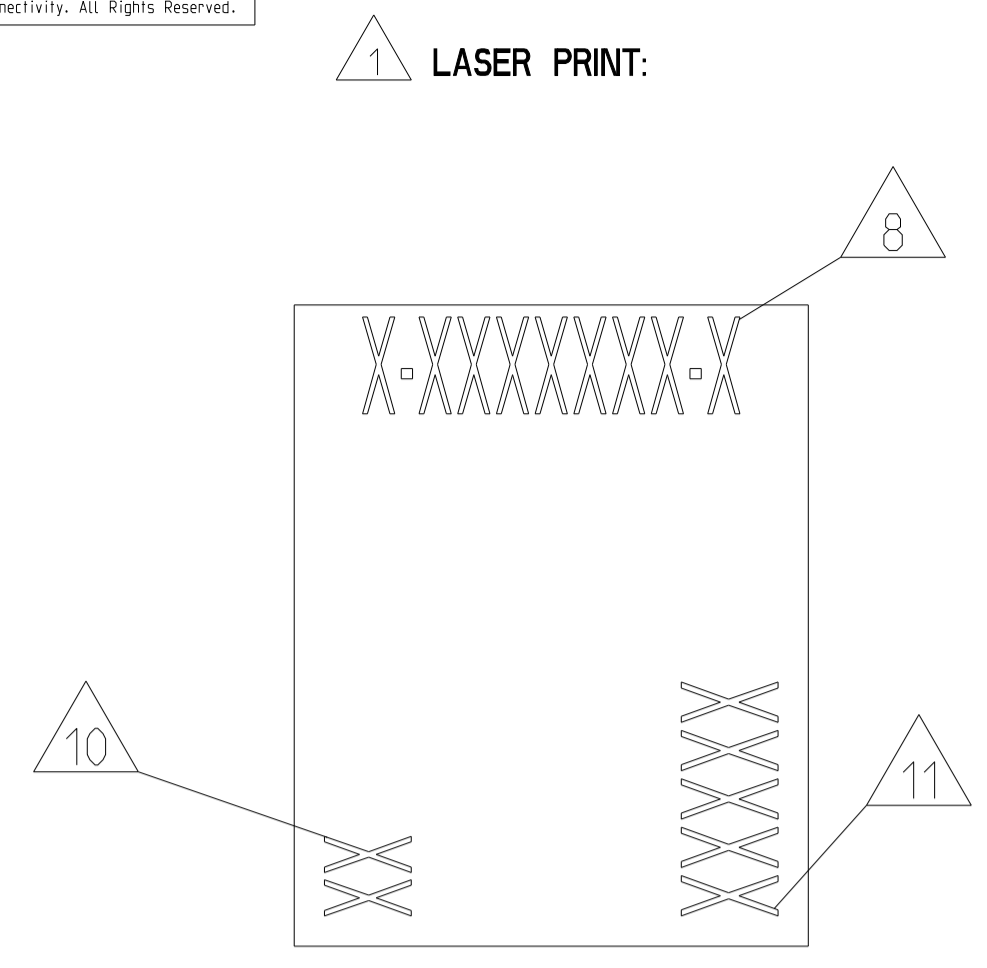
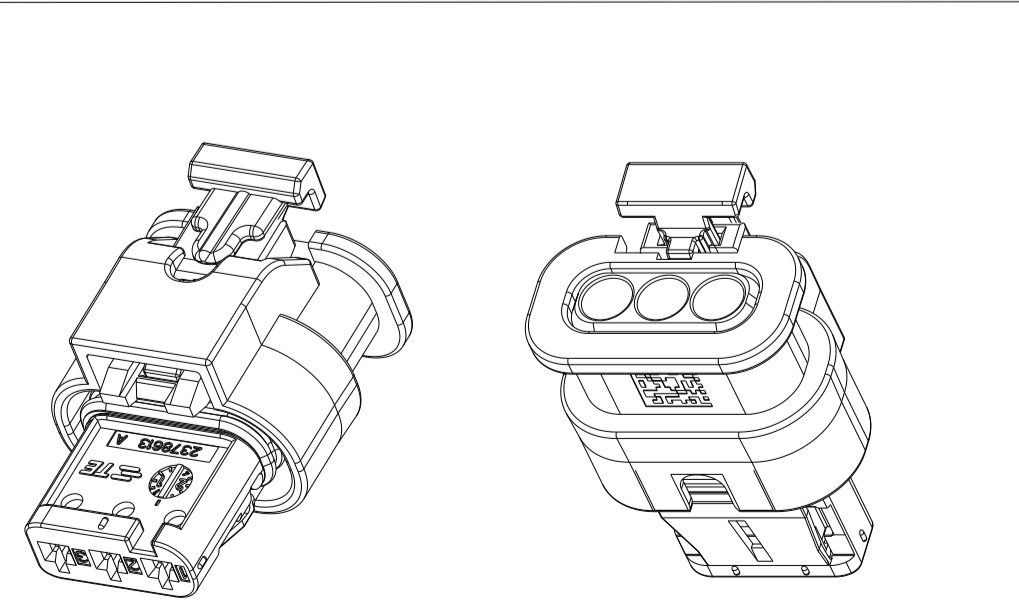

1-2378603-1 AS SHOWN

DIMENSIONS: mm 		TOLERANCES UNLESS OTHERWISE SPECIFIED: 0-10 PL ±0.1 10-30 PL ±0.05 30-50 PL ±0.025 50-100 PL ±0.015 100-150 PL ±0.01 150-200 PL ±0.0075 200-300 PL ±0.005 300-500 PL ±0.0025 ANGLES FINISH ±		DWN: 28 JUN 2021 CHK: NEMES SZILARD AP'D: GASPARD SZABOLCS PRODUCT SPEC: 108-94874 APPLICATION SPEC: 114-94767 WEIGHT: - CUSTOMER DRAWING:		NAME: 3POS NEXTGEN MCON 1.2 LL SEALED SIZE: A 00779 C=2378603 SCALE: 5:1 SHEET 1 OF 1 REV D	
--------------------	--	-------------------------------------------------------------------------------------------------------------------------------------------------------------------------------------------------------------------------	--	--------------------------------------------------------------------------------------------------------------------------------------------------------------	--	-------------------------------------------------------------------------------------------------------	--