

4

3

2

1

© - TE Connectivity. All Rights Reserved.

REVISIONS				
P	LTR	DESCRIPTION	DATE	APVD
	A2	REVISED PER ECN-26-367643	05FEB2026	MK MS

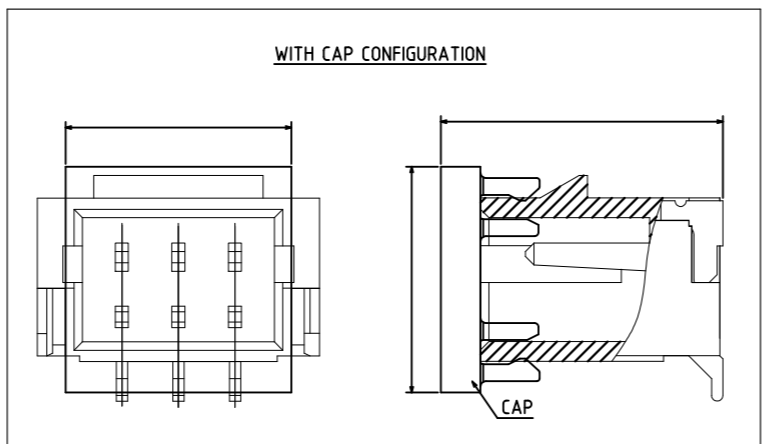
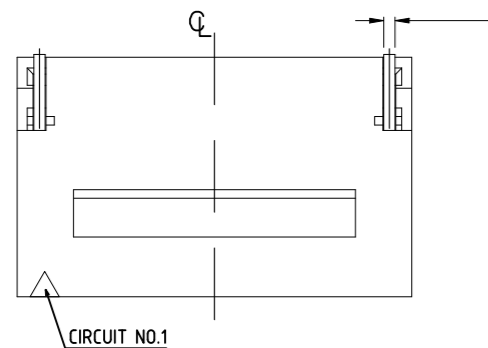

- MATERIAL:
 - HOUSING: HALOGEN FREE PLASTIC, HIGH TEMP, BLACK ,UL94V-0.
 - CONTACT: COPPER ALLOY
 - FITTING NAIL: COPPER ALLOY
- TERMINAL:
 - TYPE A: 50u" MIN. NICKEL UNDERPLATING OVERALL. 50u" MIN. MATT TIN PLATING ON CONTACT AREA AND SOLDER AREA.
 - TYPE B: 50u" MIN. NICKEL UNDERPLATING OVERALL. GOLD FLASH PLATING ON CONTACT AREA. GOLD FLASH PLATING ON SOLDER AREA.
 - TYPE C: 50u" MIN. NICKEL UNDERPLATING OVERALL. 30u" GOLD PLATING ON CONTACT AREA. GOLD FLASH PLATING ON SOLDER AREA.
- FITTING NAIL: 50u" MIN. NICKEL UNDERPLATING OVERALL. 1:GOLD FLASH PLATING ON SOLDER AREA.
- REFLOW SOLDER CAPABLE TO 260°C PER ACES SPEC.
- PACKAGE STYLE: TAPE AND REEL WITH MYLAR.

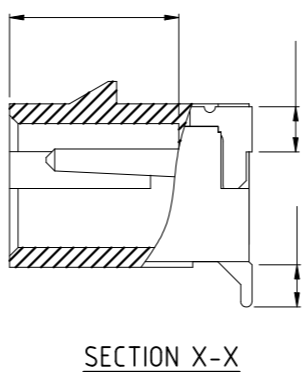
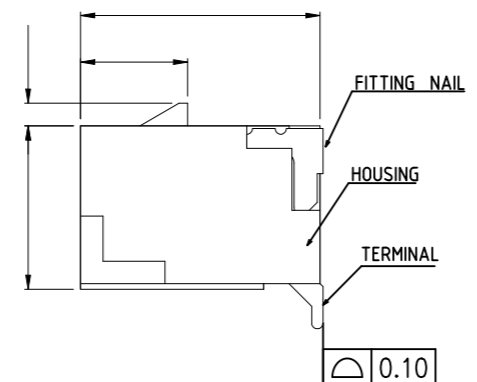
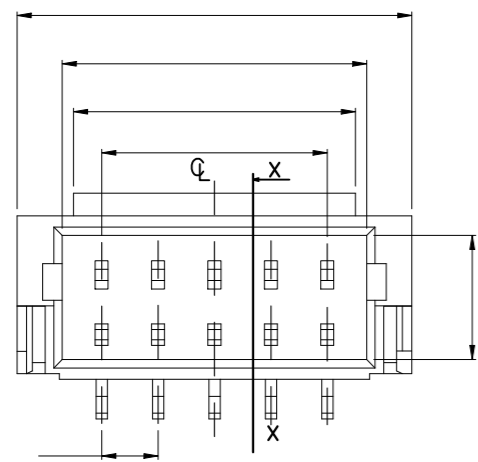

15.4	15.0	17.0	14.0	15	5-2367197-5	3-2367197-5	1-2367197-5
14.4	14.0	16.0	13.0	14	5-2367197-4	3-2367197-4	1-2367197-4
13.4	13.0	15.0	12.0	13	5-2367197-3	3-2367197-3	1-2367197-3
12.4	12.0	14.0	11.0	12	5-2367197-2	3-2367197-2	1-2367197-2
11.4	11.0	13.0	10.0	11	5-2367197-1	3-2367197-1	1-2367197-1
10.4	10.0	12.0	9.0	10	5-2367197-0	3-2367197-0	1-2367197-0
9.4	9.0	11.0	8.0	9	4-2367197-9	2-2367197-9	2367197-9
8.4	8.0	10.0	7.0	8	4-2367197-8	2-2367197-8	2367197-8
7.4	7.0	9.0	6.0	7	4-2367197-7	2-2367197-7	2367197-7
6.4	6.0	8.0	5.0	6	4-2367197-6	2-2367197-6	2367197-6
5.4	5.0	7.0	4.0	5	4-2367197-5	2-2367197-5	2367197-5
4.4	4.0	6.0	3.0	4	4-2367197-4	2-2367197-4	2367197-4
3.4	3.0	5.0	2.0	3	4-2367197-3	2-2367197-3	2367197-3
DIM .D	DIM .C	DIM ,B	DIM .A	POS. NO.	TYPE C TYPE B TYPE A		
PLATING SPEC.							
P/N							

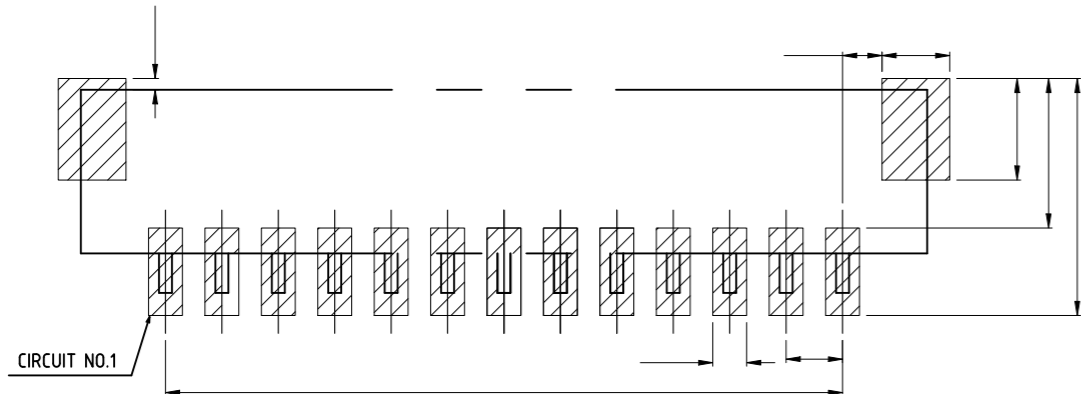

THIS DRAWING IS A CONTROLLED DOCUMENT.

DIMENSIONS: mm

TOLERANCES UNLESS OTHERWISE SPECIFIED:

0 PLC	± 0.5
1 PLC	± 0.35
2 PLC	± 0.25
3 PLC	± 0.15
4 PLC	± -
ANGLES	± 2'

MATERIAL: SEE NOTE

FINISH: -

DWN: Tommy Qian 18DEC2019

CHK: Wenke He

APVD: Wenke He

PRODUCT SPEC: 108-115169

APPLICATION SPEC: 114-115031

WEIGHT: -

TE TE Connectivity

NAME: 1.0P WTB BOARD SIDE VERTICAL TYPE WITH LATCH

SIZE: A3 CAGE CODE: 00779 DRAWING NO: C=2367197 RESTRICTED TO: -

CUSTOMER DRAWING SCALE: N/A SHEET: 1 of 2 REV: A2

4

3

2

1

© - TE Connectivity. All Rights Reserved.

REVISIONS					
P	LTR	DESCRIPTION	DATE	DWN	APVD
-	-	SEE SHEET 1	-	-	-

Packaging Specification Instructions

- As shown in the diagram, first, 55 empty spaces must be reserved on the CARRIER TAPE (plastic carrier tape) before placing the finished products. Then, cover it with the COVER TAPE (covering tape) and automatically wind it onto the REEL (plastic reel) for collection with the packaging machine.
- After completing the packaging of 1400PCS in a fixed quantity, 45 empty spaces should be reserved at the front end of the CARRIER TAPE. The COVER TAPE should be attached to the CARRIER TAPE and extend more than 400mm beyond it. Finally, wrap a fixing band around the outside and secure it with tape. Attach one barcode, product label, and environmental label each to the top of the REEL.
- Note: The COVER TAPE must not be loose, unevenly attached, or have the finished products placed in the wrong direction.
- Place one triangular cardboard on each side and at the front and back of the carton. Put a partition board on top of the carton. After loading one REEL, place it in a PE bag, add one desiccant, vacuum seal the PE bag, and pack 10 REELS in each carton. Close the carton lid and seal it with tape. Attach a shipping label to the side.
- Materials and quantities for finished product packaging: (See table)

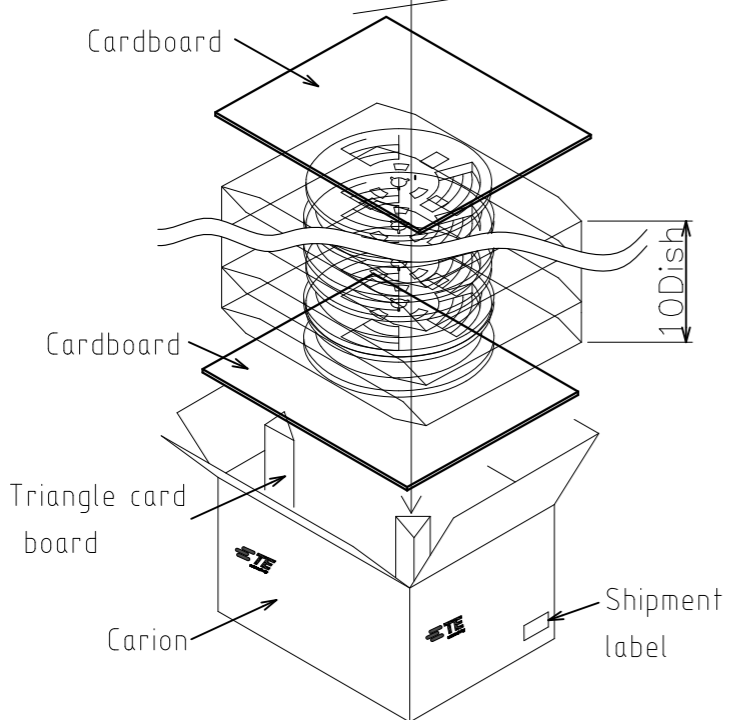
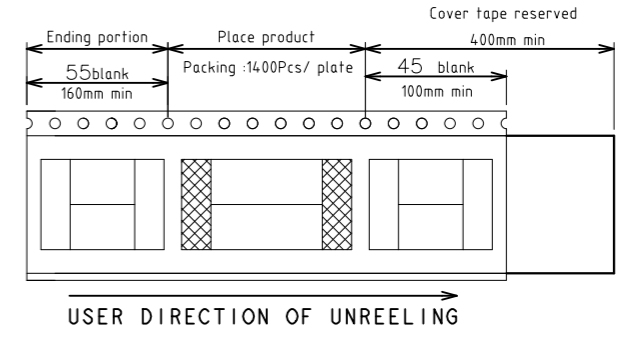
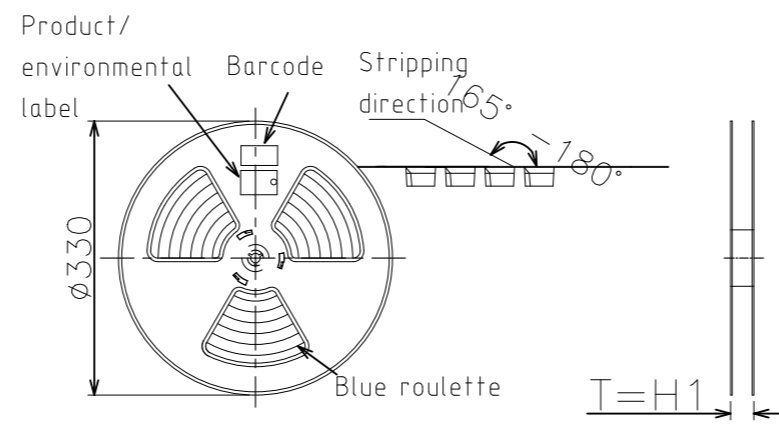
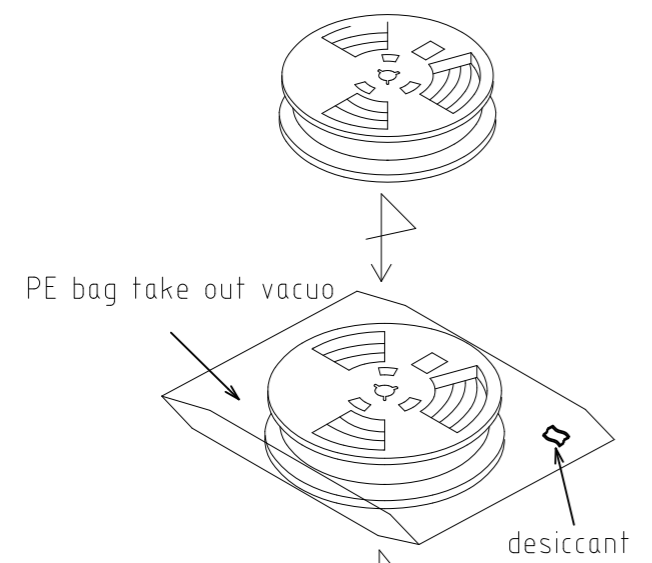
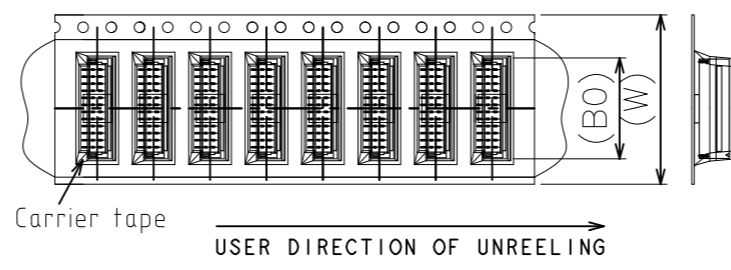
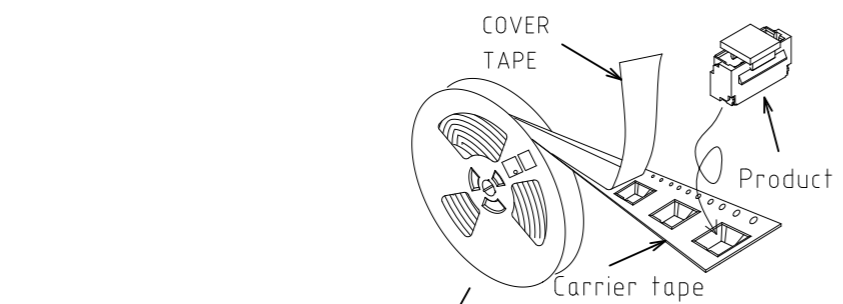

TE PN	TE PN	TE PN	W	B0	H1	Carton specifications
4-2367197-3	2-2367197-3	2367197-3	16.0	5.3	20.0	350×350×240mm
4-2367197-4	2-2367197-4	2367197-4	16.0	6.3	20.0	350×350×240mm
4-2367197-5	2-2367197-5	2367197-5	16.0	7.3	20.0	350×350×240mm
4-2367197-6	2-2367197-6	2367197-6	24.0	8.3	28.0	350×350×315mm
4-2367197-7	2-2367197-7	2367197-7	24.0	9.3	28.0	350×350×315mm
4-2367197-8	2-2367197-8	2367197-8	24.0	10.3	28.0	350×350×315mm
4-2367197-9	2-2367197-9	2367197-9	24.0	11.3	28.0	350×350×315mm
5-2367197-0	3-2367197-0	1-2367197-0	24.0	12.3	28.0	350×350×315mm
5-2367197-1	3-2367197-1	1-2367197-1	24.0	13.3	28.0	350×350×315mm
5-2367197-2	3-2367197-2	1-2367197-2	24.0	14.3	28.0	350×350×315mm
5-2367197-3	3-2367197-3	1-2367197-3	24.0	15.3	28.0	350×350×315mm
5-2367197-4	3-2367197-4	1-2367197-4	32.0	16.3	36.0	350×350×420mm
5-2367197-5	3-2367197-5	1-2367197-5	32.0	17.3	36.0	350×350×420mm

THIS DRAWING IS A CONTROLLED DOCUMENT.		DWN 18DEC2019 Tommy Qian		TE Connectivity 1.0P WTB BOARD SIDE VERTICAL TYPE WITH LATCH	
DIMENSIONS: mm		CHK - Wenke He			
TOLERANCES UNLESS OTHERWISE SPECIFIED:		APVD - Wenke He		NAME	
0 PLC ± 0.5 1 PLC ± 0.35 2 PLC ± 0.25 3 PLC ± 0.15 4 PLC ± ANGLES ±2°		PRODUCT SPEC 108-115169		RESTRICTED TO	
MATERIAL SEE NOTE		FINISH -		APPLICATION SPEC 114-115031	
		WEIGHT		SIZE CAGE CODE DRAWING NO RESTRICTED TO	
		CUSTOMER DRAWING		A3 00779 C=2367197	
		SCALE N/A		SHEET 2 OF 2 REV A2	