

REVISIONS				
P	LTN	DESCRIPTION	DATE	APVD
A		FIRST RELEASE	30JUN2020	SZ SZ
A1		ADDED NEW DASH NUMBER -6	12JAN2026	CZ LM

NOTES, UNLESS OTHERWISE SPECIFIED

1. MATERIAL:  
HOUSING - THERMOPLASTIC, GLASS PREINFORCED, COLOR, BLACK, UL 94V-0  
CONTACTS- COPPER ALLOY.

2. FINISH:  
MATING AREA - NOBLE METAL OVERALL NICKEL.  
SOLDER TAIL - MATTE TIN OVERALL NICKEL.

3. MARK P/N AND DATA CODE IN APPROX. AREA AS SHOWN.

4. OPTIONAL FEATURE BASE ON SPECIFIC PART NUMBER, SEE THE TABLE FOR DETAIL

5. NO TOOLING.

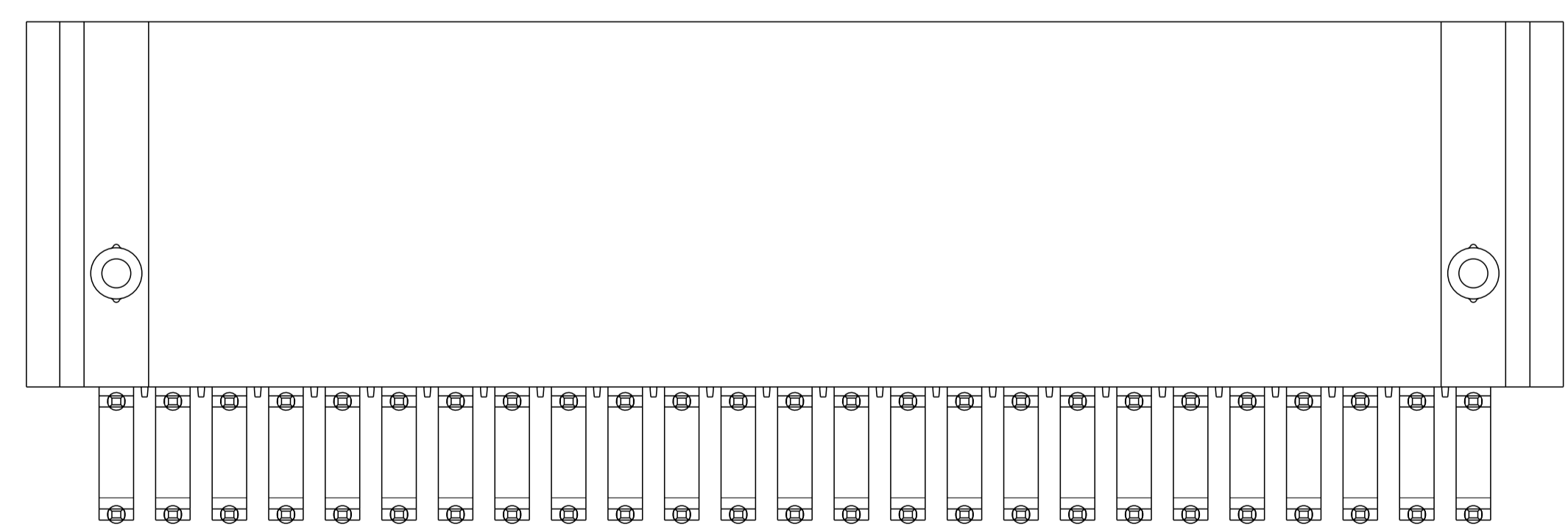
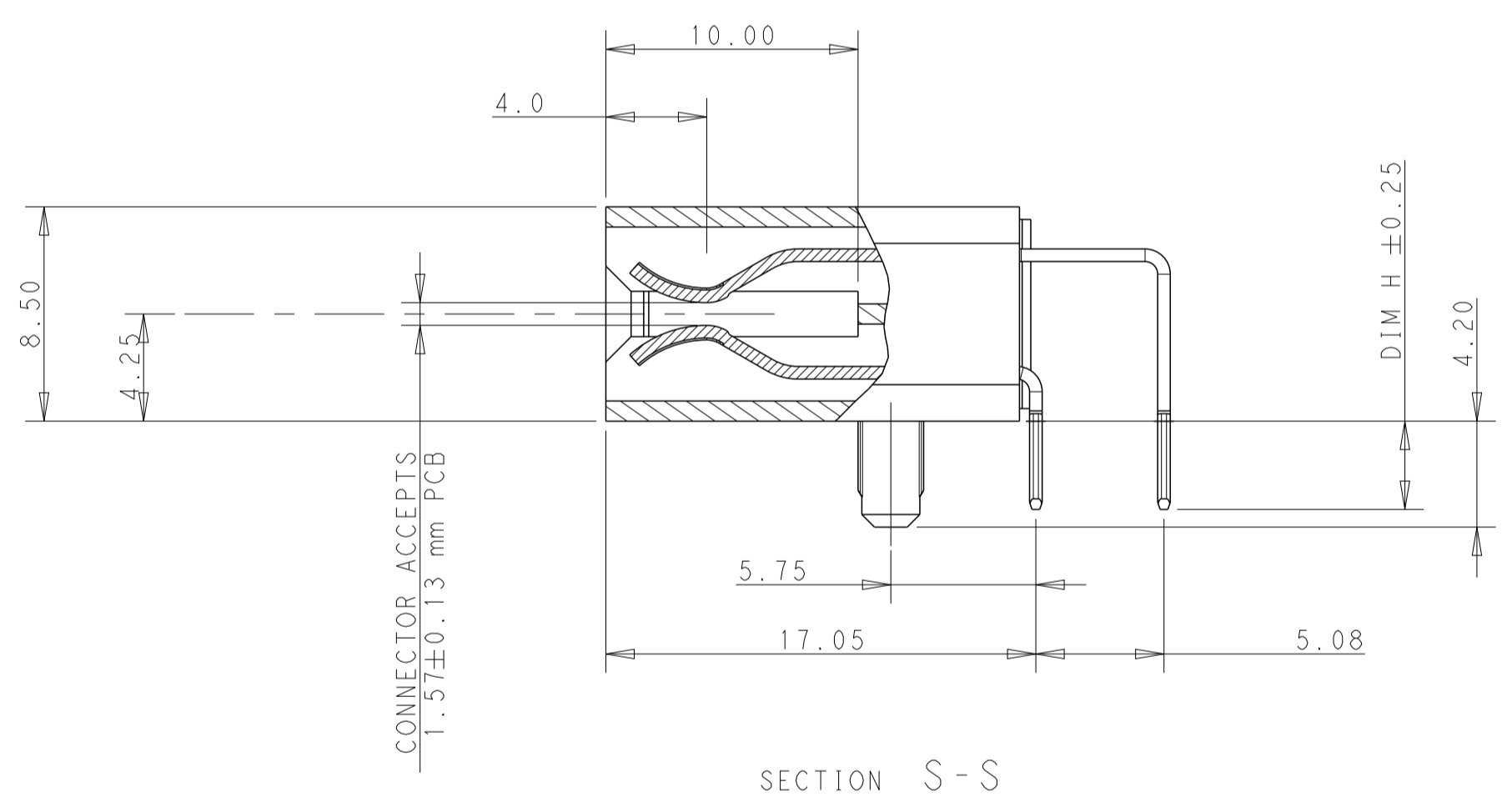
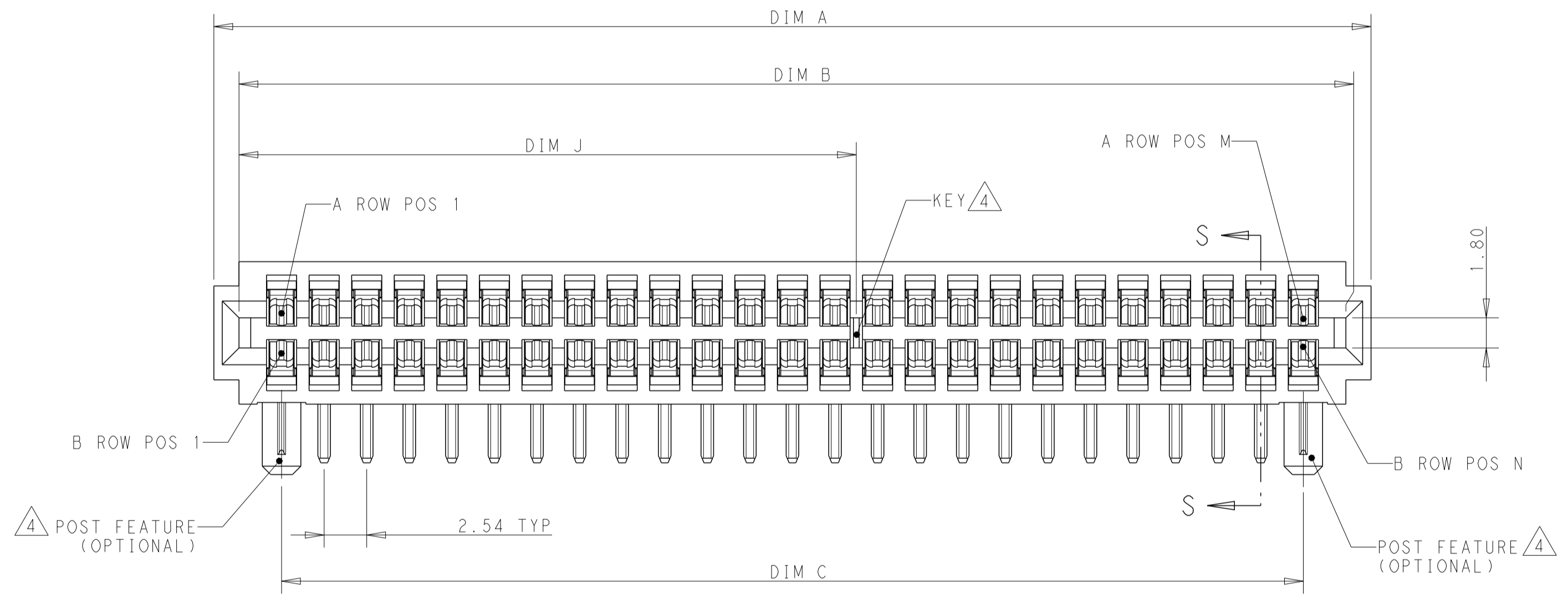
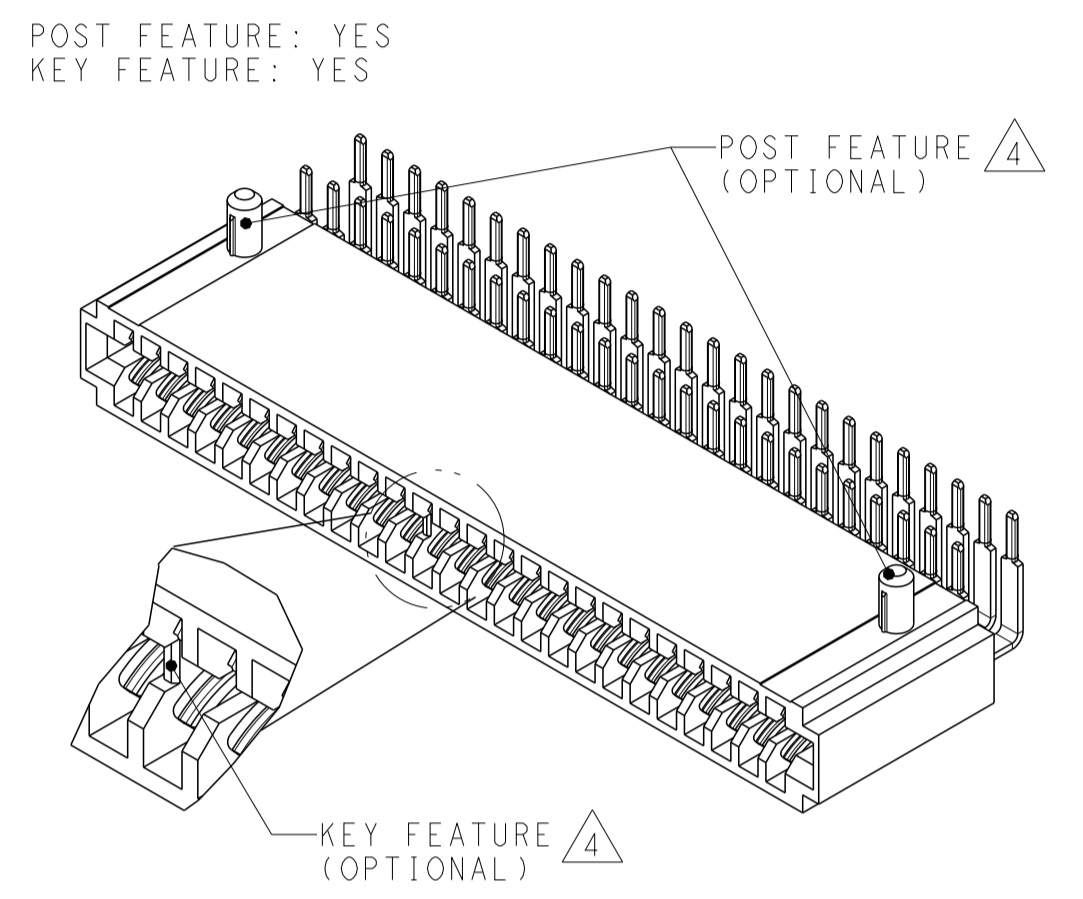
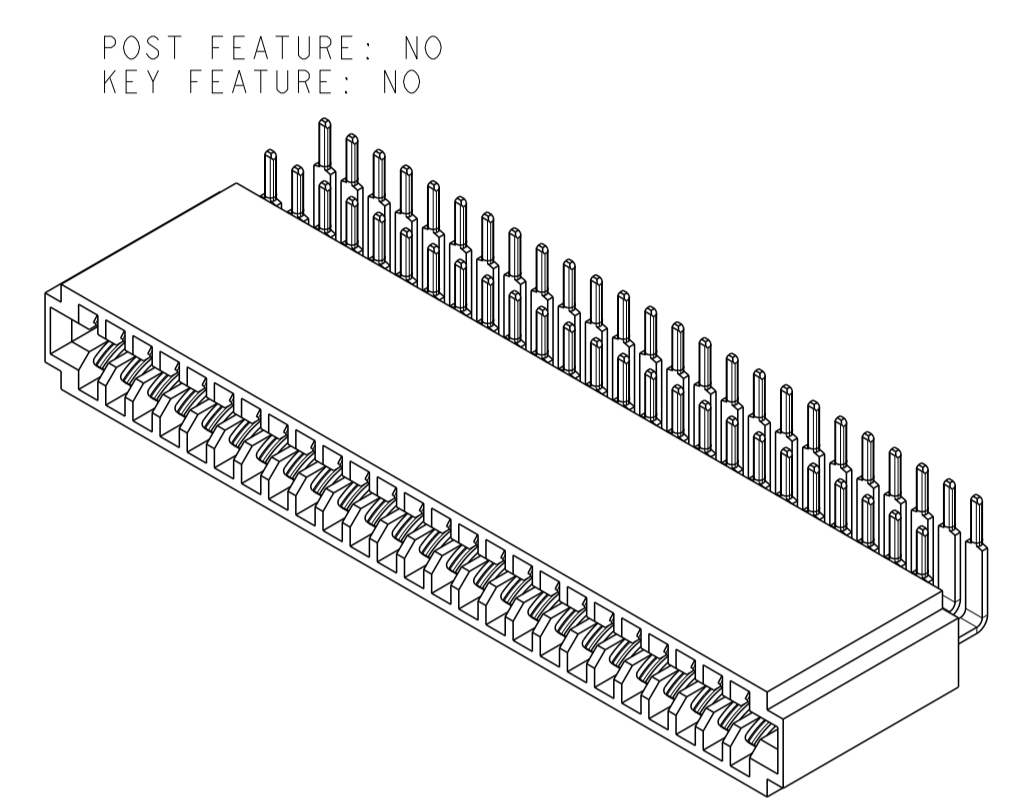
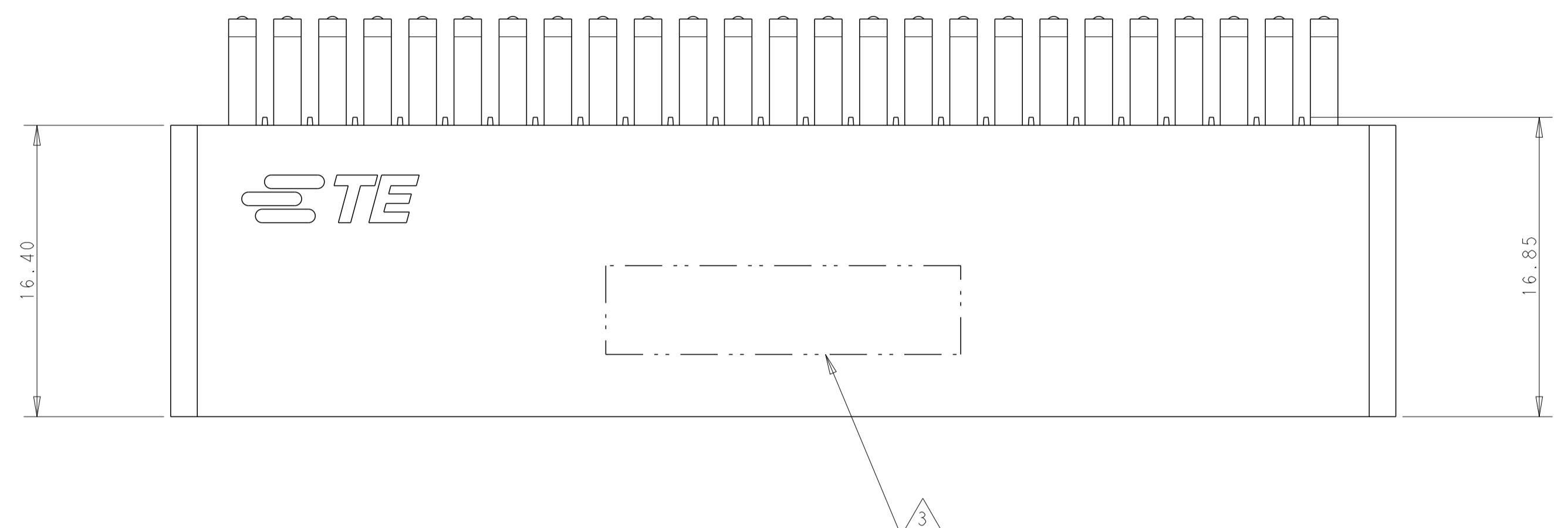

A6, B6	NO	YES	13.97	13.97	3.50	/	25.40	12.70	30.18	/	30.48	33.48	11	11	2358256-6
	NO	YES	34.29	36.83	3.50	/	60.96	30.48	65.74	/	66.04	69.04	25	25	2358256-5
	NO	NO	/	/	2.50	/	60.96	30.48	65.74	/	66.04	69.04	25	25	2358256-4
	NO	YES	/	/	3.50	17.78	17.78	8.89	22.56	17.78	22.86	25.86	8	8	2358256-3
	NO	YES	34.29	36.83	3.50	60.96	60.96	30.48	65.74	60.96	66.04	69.04	25	25	2358256-2
	NO	NO	/	/	3.50	/	60.96	30.48	65.74	/	66.04	69.04	25	25	2358256-1
OMITTED PINS	POST	KEY	DIM K	DIM J	DIM H	DIM G	DIM F	DIM E	DIM D	DIM C	DIM B	DIM A	N	M	PART NUMBER

THIS DRAWING IS A CONTROLLED DOCUMENT.

DIMENSIONS: mm

TOLERANCES UNLESS OTHERWISE SPECIFIED:

0 PLC	±0.5
1 PLC	±0.5
2 PLC	±0.75
3 PLC	±1.0
4 PLC	±1.0
ANGLES	±0.5
FINISH	±0.5

MATERIAL: -

FINISH: -

APVD: SEAN ZHANG 11JUN2019

CHK: SUNY ZHAO 11JUN2019

NAME: SINGLE BEAM CARD EDGE RIGHT ANGLE

PRODUCT SPEC: -

APPLICATION SPEC: -

WEIGHT: -

CUSTOMER DRAWING

SCALE: 2:1

SHEET 1 OF 2

REV A1

REVISIONS				
P	LTN	DESCRIPTION	DATE	APVD
-	-	SEE SHEET 1	-	-

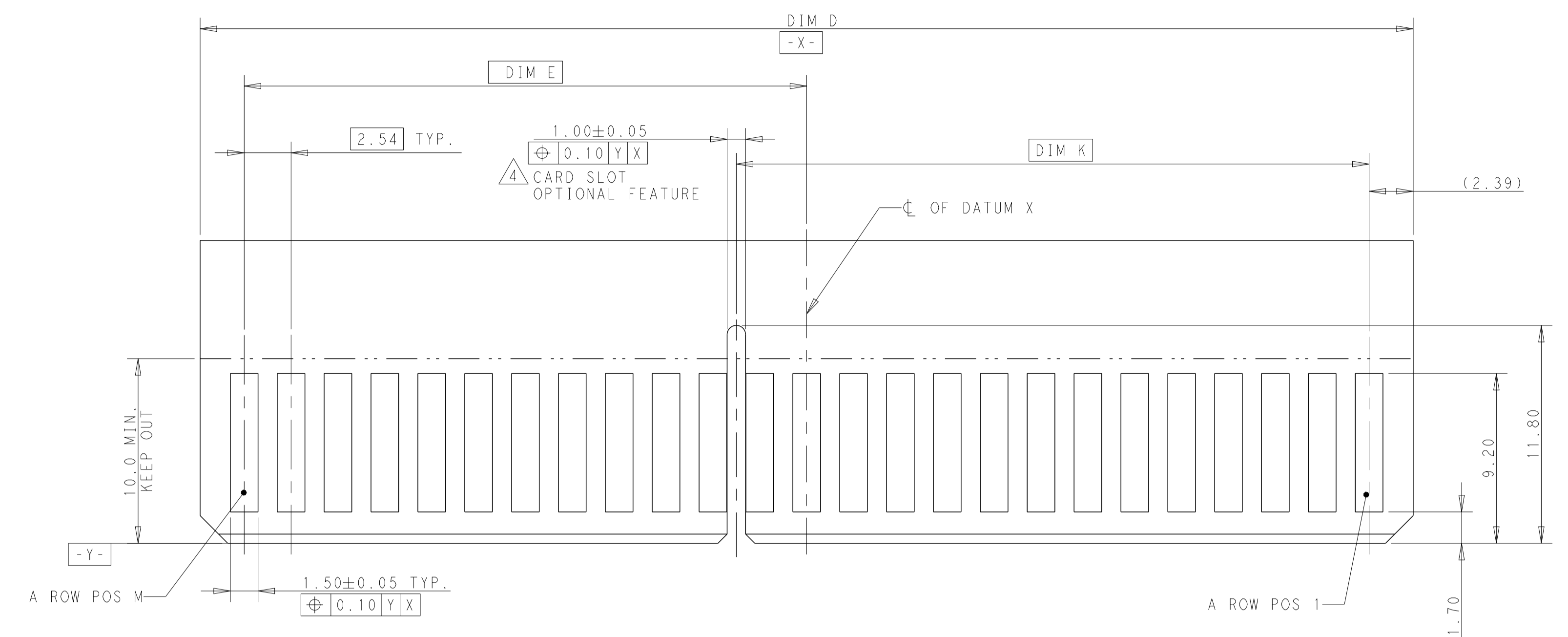

RECOMMENDED MATING BOARD EDGE CONFIGURATION  
(PRIMARY SIDE SHOWN)

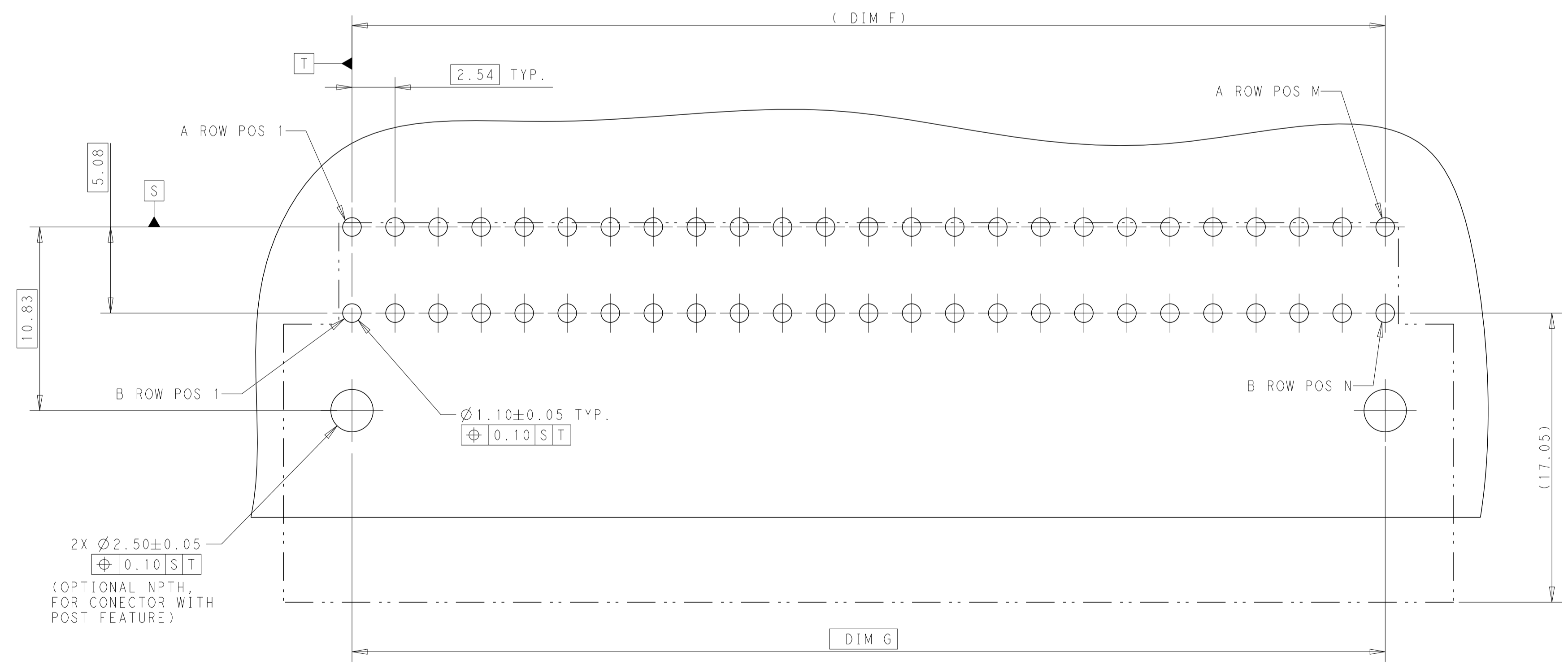

RECOMMENDED MOUNTING BOARD CONFIGURATION LAYOUT  
VIEW FROM COMPONENT SIDE

THIS DRAWING IS A CONTROLLED DOCUMENT.		OWN: SEAN ZHANG	11JUN2019	
DIMENSIONS: mm		CHK: SUNY ZHAO	11JUN2019	
TOLERANCES UNLESS OTHERWISE SPECIFIED:		APVD: SUNY ZHAO	11JUN2019	NAME: SINGLE BEAM CARD EDGE RIGHT ANGLE
0 PLC	±	PRODUCT SPEC		APPLICATION SPEC
1 PLC	±0.10			
2 PLC	±0.05			
3 PLC	±			
4 PLC	±			
ANGLES	±			
MATERIAL: TBD		WEIGHT: -	SIZE: A1	CAGE CODE: -
			DRAWING NO: C=2358256	RESTRICTED TO: -
		CUSTOMER DRAWING	SCALE: 2:1	SHEET: 2 OF 2
				REV: A1