

THIS DRAWING IS UNPUBLISHED.
 DIFFUSION RESTREINTE AMP
 © COPYRIGHT 2008 BY TYCO ELECTRONICS CORPORATION. ALL RIGHTS RESERVED.
 TOUS DROITS RESERVES

RELEASED FOR PUBLICATION
 LIBRE A LA DIFFUSION
 2008

LOC F
 DIST 00

REVISIONS

P	LTR REV	DESCRIPTION MODIFICATIONS	DATE	DWN DESS.	APVD APP.
C		PACKAGING MODIFICATION, SET UP TRANSITION	31MAR2008	PF s	JDr
-		BETWEEN TAB AND CAGE, TYCO TITLE BLOCK,			
-		ADD NEW PN, CRIMPING SPEC REPLACED BY No			
D		DRAWING UPDATE	02JAN2026	SB	SK

R = IDENTIFICATION MATIERE VOIR TABLEAU
 MATERIAL IDENTIFICATION SEE TABLE

ECHELLE 2.0
 SCALE 2.0

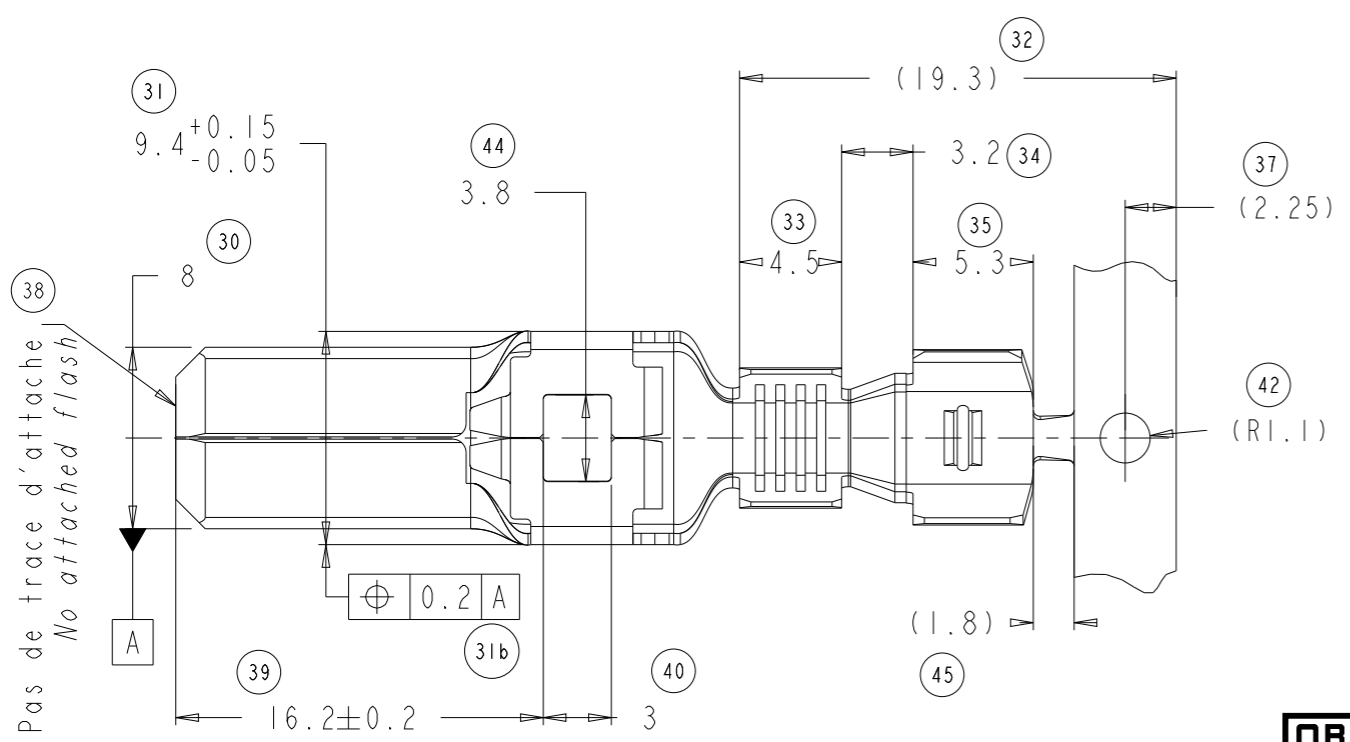
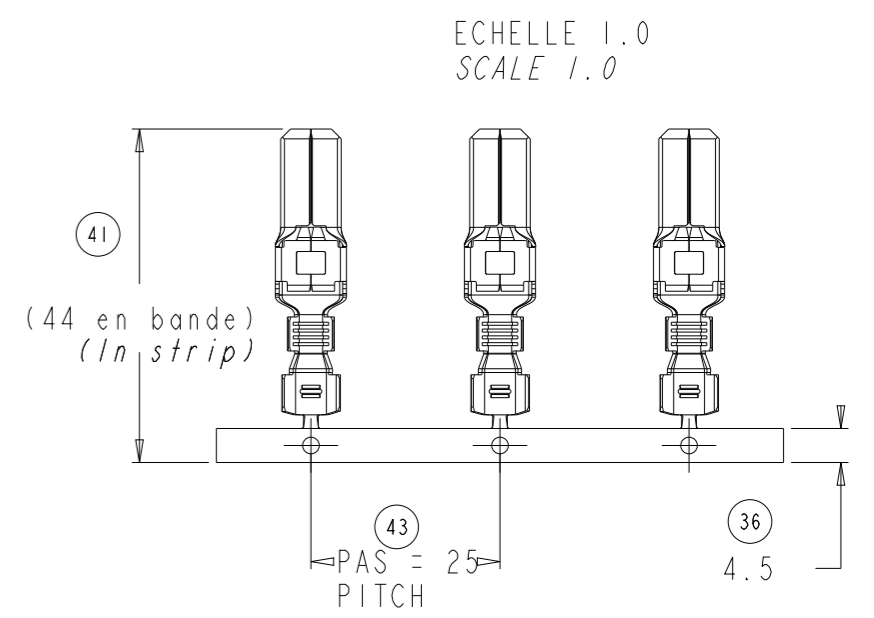
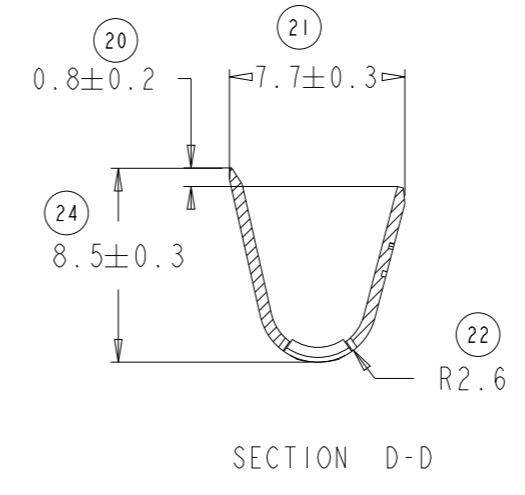
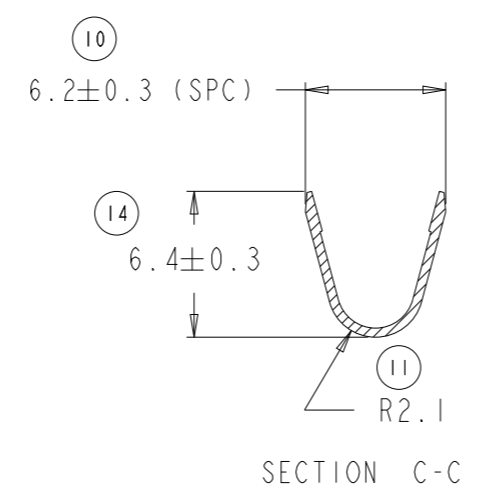
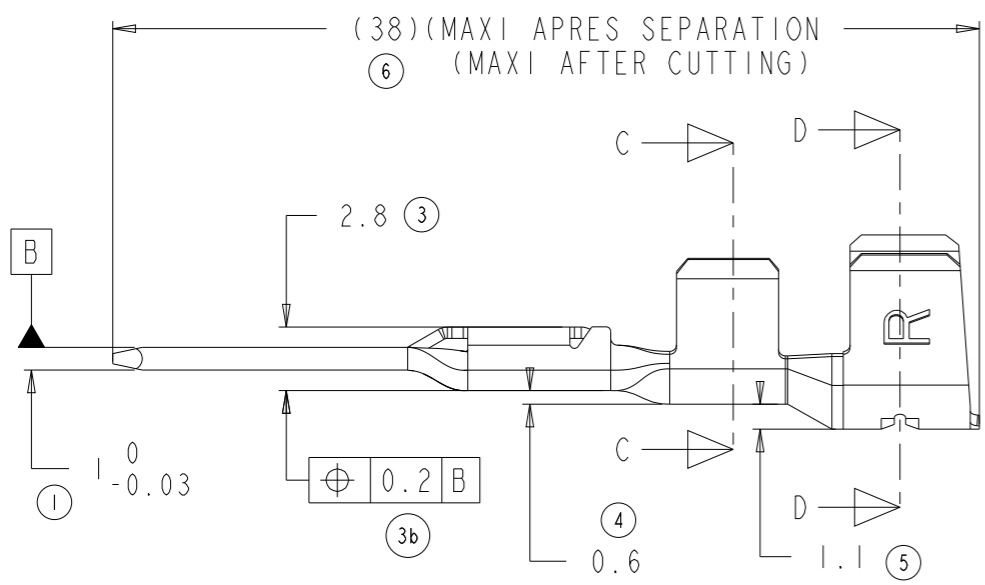
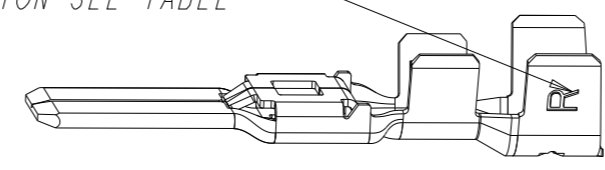

() = COTE DONNEE A TITRE INDICATIF
 () = DIMENSION ONLY FOR INFORMATION

JOINT UNIFILAIRE ASSOCIE - ASSOCIATE WIRE SEAL		
DESIGNATION DEFINITION	PN TE TE PN	PN CLIENT CUSTOMER PN
JOINT UNIFILAIRE A SERTIR 3 A 6 mm ² DIAMETRE FIL 3.5 A 4.5 mm SINGLE SEAL 3 TO 6 mm ² WIRE DIAMETER FROM 3.5 TO 4.5mm	1544316-1	

PN CLIENT CUSTOMER PN	PN TE TE PN	R : MATIERE R : MATERIAL	MATIERE MATERIAL	PROTECTION FINISH
	1544332-1	SANS WITHOUT	LAITON / BRASS SPEC SM 125	Sn : 0.8 A 1.2µ SPEC 112-16-4
	1544332-2	R	BRONZE / BRONZE SPEC 100-221	Sn : 1 A 2µ SPEC 112-20-4

OBSOLETE

CONDITIONNEMENT - PACKAGING

- CONDITIONNEMENT SELON SPECIFICATIONS: 107-15603
- NOMBRE DE PIECES PAR GALETTE = 1100.
- NOMBRE DE GALLETES PAR CARTON = 2
- PACKAGING ACCORDING TO SPECIFICATIONS No: 107-15603
- NUMBER PARTS BY WHEEL = 1100.
- NUMBER OF WHEELS BY BOX = 2

THIS DRAWING IS A CONTROLLED DOCUMENT FOR TYCO ELECTRONICS CORPORATION IT IS SUBJECT TO CHANGE AND THE CONTROLLING ENGINEERING ORGANIZATION SHOULD BE CONTACTED FOR THE LATEST REVISION. CE PLAN EST UN DOCUMENT CONTROLE PAR AMP INCORPORATED. IL EST SUSCEPTIBLE D'ETRE REVISE. CONTACTER LE SERVICE TECHNIQUE D'AMP DE FRANCE POUR OBTENIR LA DERNIERE REVISION.		DWN /DESSINE 31MAR08 P. FLORES	Tyco Electronics France SAS RN 90, 38530 Chapareillan	
DIMENSIONS: mm		CHK /VERIFIE 31MAR08 L. CORONELLI	NAME /TITRE LANGUETTE 8NG1 - GAMME 3 A 6 mm ² 8NG1 TAB - RANGE 3 TO 6mm ²	
TOLERANCES UNLESS OTHERWISE SPECIFIED: TOLERANCES NON SPECIFIEES (SUIV NB DE DECIMALES): 1 PLC /DEC: ± 2 PLC /DEC: ±0.1 3 PLC /DEC: ± 4 PLC /DEC: ± ANGLES ±2°		APVD /APPROUVE 31MAR08 J. DAHER	PRODUCT SPEC SPEC. PRODUIT 108-15346	SIZE FORMAT A3
MATERIAL MATIERE SEE TABLE		FINISH FINITION SEE TABLE	APPLICATION SPEC SPEC. APPLICATION 114-15112	CAGE CODE 00779
		WEIGHT MASSE APPROX. 0.003kg	DRAWING NO No PLAN C=1544332	RESTRICTED TO RESERVE A
		CUSTOMER DRAWING /PLAN CLIENT	UNIQUEMENT POUR REFERENCE	SCALE ECHELLE 3
			SHEET FEUILLE 1	OF DE 1
				REV D