



M7100

Pressure Transducer

SPECIFICATIONS

- Performance standard on and off highway engine and vehicle OEMs
- Rugged for heavy equipment and outdoor use
- Designed specifically for high volume applications
- Stainless steel wetted surfaces
- Medium to high pressures
- UL Certified
- Gage

The M7100 pressure transducer from the Microfused line of MEAS sets a new price performance standard for demanding engine and vehicle, and industrial applications. This transducer is suitable for measurement of liquid or gas pressure, even for difficult media such as contaminated water, steam and corrosive fluids.

The transducer pressure cavity is machined from a solid piece of 17-4 PH stainless steel. The standard version includes a 1/4 NPT pipe thread allowing a leak-proof, all metal sealed system. This automotive grade pressure transducer with stainless steel hermetic pressure ports and integral electrical connector can boast up to 10,000psi (700bar). The M7100 is UL certified and exceeds the latest industrial requirements including surge protection and is overvoltage protected in both positive and reverse polarity.

FEATURES

- Hermetic Pressure Ports
- Integral Electrical Connector
- Survives High Vibration
- $\pm 0.25\%$ Accuracy
- Water Resistant 1M Immersion

APPLICATIONS

- On and Off Highway Engines and Vehicles
- HVAC Refrigeration Controls
- Compressors
- Hydraulics
- Energy and Water Management

STANDARD RANGES

Range (psi)	Range (bar)	Gage
0 to 150	0 to 010	•
0 to 200	0 to 014	•
0 to 300	0 to 020	•
0 to 500	0 to 035	•
0 to 01K	0 to 070	•
0 to 1K5	0 to 100	•
0 to 03K	0 to 200	•
0 to 05K	0 to 350	•
0 to 7K5	0 to 500	•
0 to 10K	0 to 700	•

PERFORMANCE SPECIFICATIONS

Ambient Temperature: 25°C (unless otherwise specified);

PARAMETERS	MIN	TYP	MAX	UNITS	NOTES
Load Resistance	10			KΩ	
Accuracy (combined linearity, hysteresis & repeatability)	-0.25		0.25	%Span	1
Total Error Band	-1.0		1.0	%Span	2
Compensated Temperature	-20		+85	°C	
Operating Temperature	-40		+125	°C	3
Storage Temperature	-50		+125	°C	
Insulation Resistance (500V _{DC})	100			MΩ	4
Short Circuit Protected		Yes			
Output Noise @ 1kHz		10		mV	
Long Term Stability	-0.25		0.25	%Span/Year	
Frequency Response @ -3dB		1		kHz	

Notes

- Best fit straight line.
- TEB includes all accuracy errors, thermal errors, span and zero tolerances over the compensated temperature range.
- Temperature range for product with standard cable is -20°C to +105°C.
- Between sensor body to any pins of connector.
- The maximum pressure that can be applied without changing the transducer's performance or accuracy.
- The maximum pressure that can be applied to a transducer without rupture of either the sensing element or transducer.
- Refer to pressure port Listing notes for installation recommendations.
- This product can be configured for custom OEM requirements. Contact Factory for different transfer function. See "Pressure Transfer Function" diagram.
- Maximum temperature range for product with standard cable is -20°C to 105°C.
- Do not apply torque to connector housing of transducer.
- To ensure proper environmental sealing and electrical connections when using a mating connector, follow the connector manufacturer's installation guidelines.

ENVIRONMENTAL SPECIFICATIONS

Ambient Temperature: 25°C (unless otherwise specified)

PARAMETERS	MIN	TYP	MAX	UNITS	NOTES
Humidity (@40°C)			93	%RH	
Pressure Overload			2X	Rated	5
Pressure Burst			5X	Rated	6
Pressure Cycle	10M			Cycles	
Media, Pressure Port	Fluids compatible with 17-4PH Stainless Steel				
Mechanical Vibration	20g, 10 ~ 2000Hz MIL-STD-810C, Method 514.2, Curve L				
Mechanical Shock	Half-Sine, Peak: 50g, 11ms MIL-STD-202, Method 213B, Condition A				
Package Protection	IP67 (IEC60529)				

AGENCY APPROVALS

RoHS: RoHS 2 (Directive 2011/65/EU)	
Industrial Control Equipment	CSA 22.2 No. 14-10
UL508 Certified	
EMC Performance Criteria:	Output Change < ±1.5% FSO
ESD	8kV Contact/15kV Air; Discharge Rate >10s
IEC 61000-4-2	
EM Field	100V/m, 1kHz 80% Modulation, 80 ~ 1000MHz
IEC 61000-4-3	
Electrical Fast Transient	Level 2, 1kV each line, capacitance coupling
IEC 61000-4-4	
Surge	Level 2, 42Ω Impedance, Figure 11 (L-L 500V, L-E 1kV)
IEC 61000-4-5	
Conducted RF	Level 2, 3V/130dB, 150kHz ~ 80MHz, 2s Dwell, Clamp Injection
IEC 61000-4-6	
Pulse Magnetic Field	Level 3, 100A/m, 10 second pulse interval
IEC 61000-4-9	
Emission	Class B, 30dB @ 30-230MHz, 37dB @ 230 – 1000MHz
IEC 55022	

PRESSURE PORT INFORMATION

Pressure Port Options	Dim A	Tightening Torque (Nm)
2 = G1/4, BS5380, Male	.43 [11.0]	30~35
4 = 7-16-20 UNF, SAE J1926-2, Male, w/ O-Ring	.36 [9.1]	18~20
5 = 1/4-18 NPT Male	.56 [14.2]	2~3 T.F.F.T.
6 = 1/8-27 NPT Male	.38 [9.7]	2~3 T.F.F.T.
E = R1/4-19, Male	.56 [14.2]	2~3 T.F.F.T.
F = G1/4-19, BS5380, Female	.64 [16.3]	30~35
P = 7/16-20UNF Female w/ Integral Valve Depressor; 1/4 Flare Gasket SAE J513C, Copper	.64 [16.3]	15~16
Q = M10 x 1.0, ISO 6149-2, Male	.37 [9.5]	15~16
S = M12 x 1.5, ISO 6149-2, Male	.43 [11.0]	28~30
G = M14 x 1.5, ISO 6149-2, Male	.43 [11.0]	30~35
U = G1/4, DIN 3852-E, Male	.47 [12.0]	30~35

Notes: Installation

*T.F.F.T.: Turns From Finger Tight

Transducers can be installed by either spanner or deep socket. Torque values provided are for reference: actual torque depends upon mating port material, surface finish, lubrication and sealing mechanism. Transducers calibration and/or zero may shift if part is over-torqued during installation. Check for a zero shift after installing.

CONNECTOR INFORMATION

Connector	Connector, Pin Plating	Connector, Mating
Packard Metri-Pack 150 Series	<i>powerandsignal.com</i> 0.003 – 0.005 mm Sn	Housing P/N: 12065287 Terminals P/N: 12103881
Sumitomo HV040 Series	<i>sumitomokenki.com</i> 0.003 mm Sn over 0.0005 – 0.001 mm Cu	Housing P/N: 6189-6907 Terminals P/N: 8100-3067/8
AMP Econoseal-J Mark II 070 Series	<i>te.com</i> 0.0004 mm Au over 0.0013 mm Ni	Housing P/N: 174357 Terminals P/N: 171630

DIMENSIONS

Dimensions are in INCHES [mm]

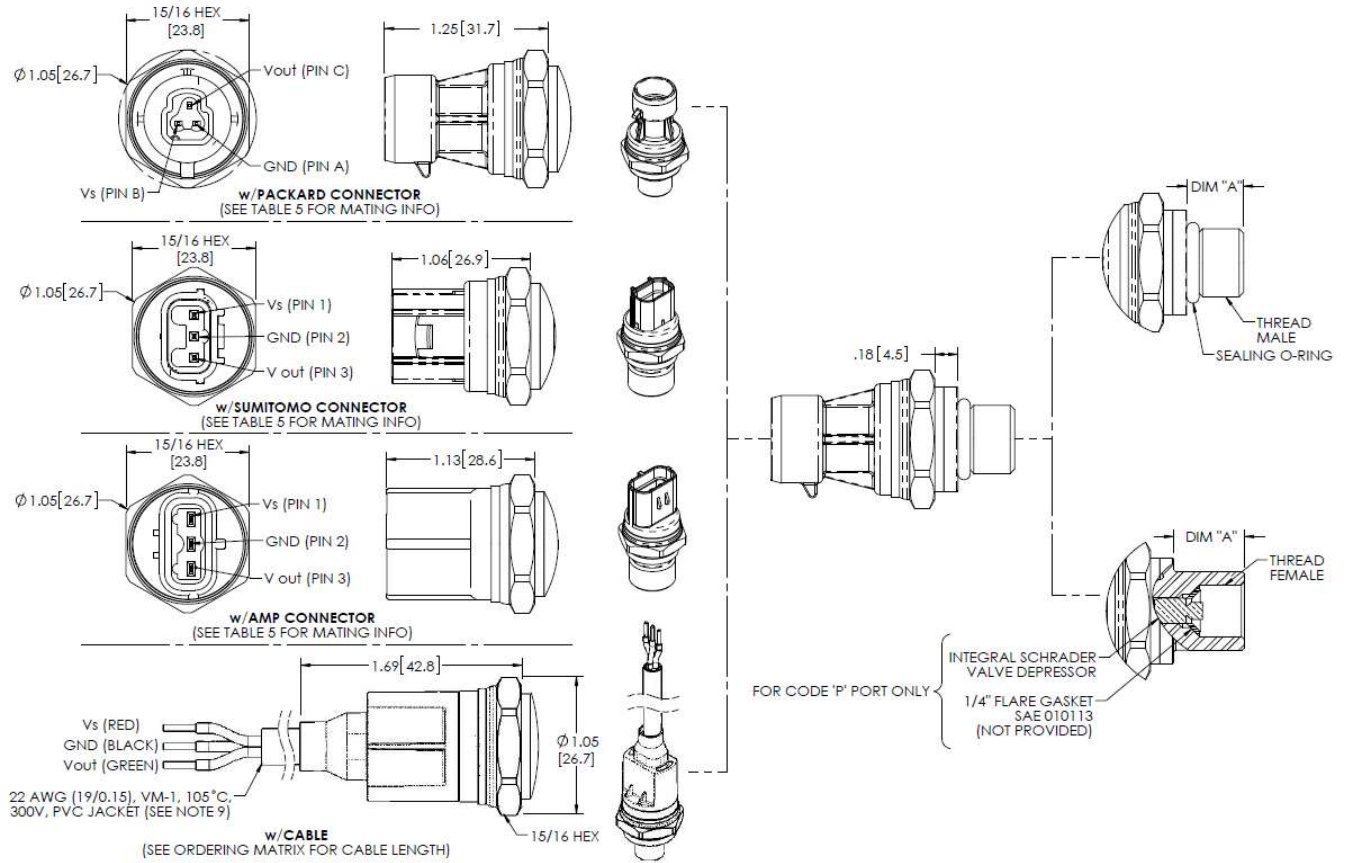

CHARTS

Pressure Transfer Function

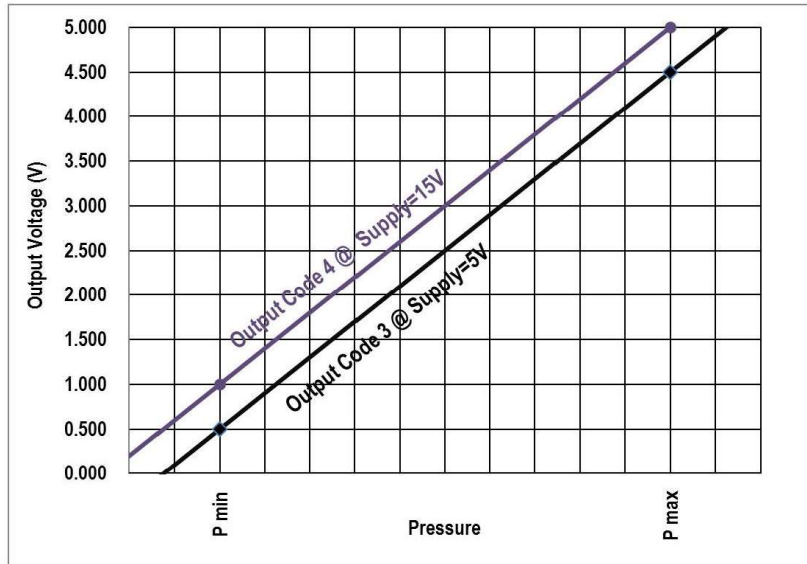

Output Type vs. Supply

Output Type (Code)	3	4
Supply Voltage	4.75 ~ 5.25V*	8 ~ 32V
Supply Current	4.0 ~ 10.0mA	
Output Voltage	0.5 ~ 4.5V*	1.0 ~ 5.0V
Reverse Voltage	16V	
Overvoltage Protection	16V	32V

* Output ratiometric to supply voltage

Pressure Range

psi	bar
150P	010B
200P	014B
300P	020B
500P	035B
01KP	070B
1K5P	100B
03KP	200B
05KP	350B
7K5P	500B
10KP	700B

Connection Type

1	Cable 2 feet
2	Cable 4 feet
3	Cable 10 feet
7	AMP070 Connector
8	HV040 Sumitomo
9	Packard Connector
M	Cable 1 m
N	Cable 2 m
P	Cable 5 m
R	Cable 10 m

ORDERING INFORMATION

M71 3 M – 300P G – 2 0 0000

Output	
Code	Output Voltage
3	0.5 – 4.5 V
4	1.0 – 5.0 V

Cable/Connectors	
1	Cable, 2 feet
2	Cable, 4 feet
3	Cable, 10 teet
7	Amp Connector
8	HV040 Sumitomo
9	Packard Connector
M	Cable 1 meter
N	Cable, 2 meter
P	Cable, 5 meter
R	Cable, 10 meter

Pressure Range [psi]	
psi	bar
150P	010B
200P	014B
300P	020B
500P	035B
01KP	070B
1K5P	100B
03KP	200B
05KP	350B
7K5P	500B
10KP	700B

Port Material	
0	17-4PH Stainless Steel

Pressure Port	
Code	Port
2	G1/4, BS5380, Male
4	7/16-20 UNF, SAE J1926-2, Male, w/ O-ring
5	1/4-18 NPT Male
6	1/8-27 NPT Male
E	R1/4-19 Male
F	G1/4-19, BS5380, Female
P	7/16-20 UNF Female w/ Integral Valve Depressor; 1/4 Flare Gasket SAE J513C, Copper
Q	M10x1.0 ISO 6149-2, Male
S	M12x1.5, ISO 6149-2, Male
G	M14x1.5, ISO 6149-2, Male
U	G1/4, DIN 3852-E, Male

NORTH AMERICA

Measurement Specialties, Inc.,
a TE Connectivity Company
Phone: 1 800-522-6752
Email: customercare.frm@te.com

EUROPE

Measurement Specialties (Europe), Ltd.,
a TE Connectivity Company
Phone: +31 73 624 6999
Email: customercare.lcsb@te.com

ASIA

Measurement Specialties (China), Ltd.,
a TE Connectivity Company
Phone: +86 0400-820-6015
Email: customercare.shzn@te.com

TE.com/sensorsolutions

Measurement Specialties, Inc., a TE Connectivity company.

Measurement Specialties, TE Connectivity, TE Connectivity (logo) and EVERY CONNECTION COUNTS are trademarks. All other logos, products and/or company names referred to herein might be trademarks of their respective owners.

The information given herein, including drawings, illustrations and schematics which are intended for illustration purposes only, is believed to be reliable. However, TE Connectivity makes no warranties as to its accuracy or completeness and disclaims any liability in connection with its use. TE Connectivity's obligations shall only be as set forth in TE Connectivity's Standard Terms and Conditions of Sale for this product and in no case will TE Connectivity be liable for any incidental, indirect or consequential damages arising out of the sale, resale, use or misuse of the product. Users of TE Connectivity products should make their own evaluation to determine the suitability of each such product for the specific application.

© 2015 TE Connectivity Ltd. family of companies All Rights Reserved.