

USABLE WITH TAB 0.8mm AND TAB 0.6mm THICKNESS
Verwendbar mit Flachstecker 0.8mm und 0.6mm Dicke

CONTACTS FOR FLR-CABLE
Kontakte fuer FLR-Leitung

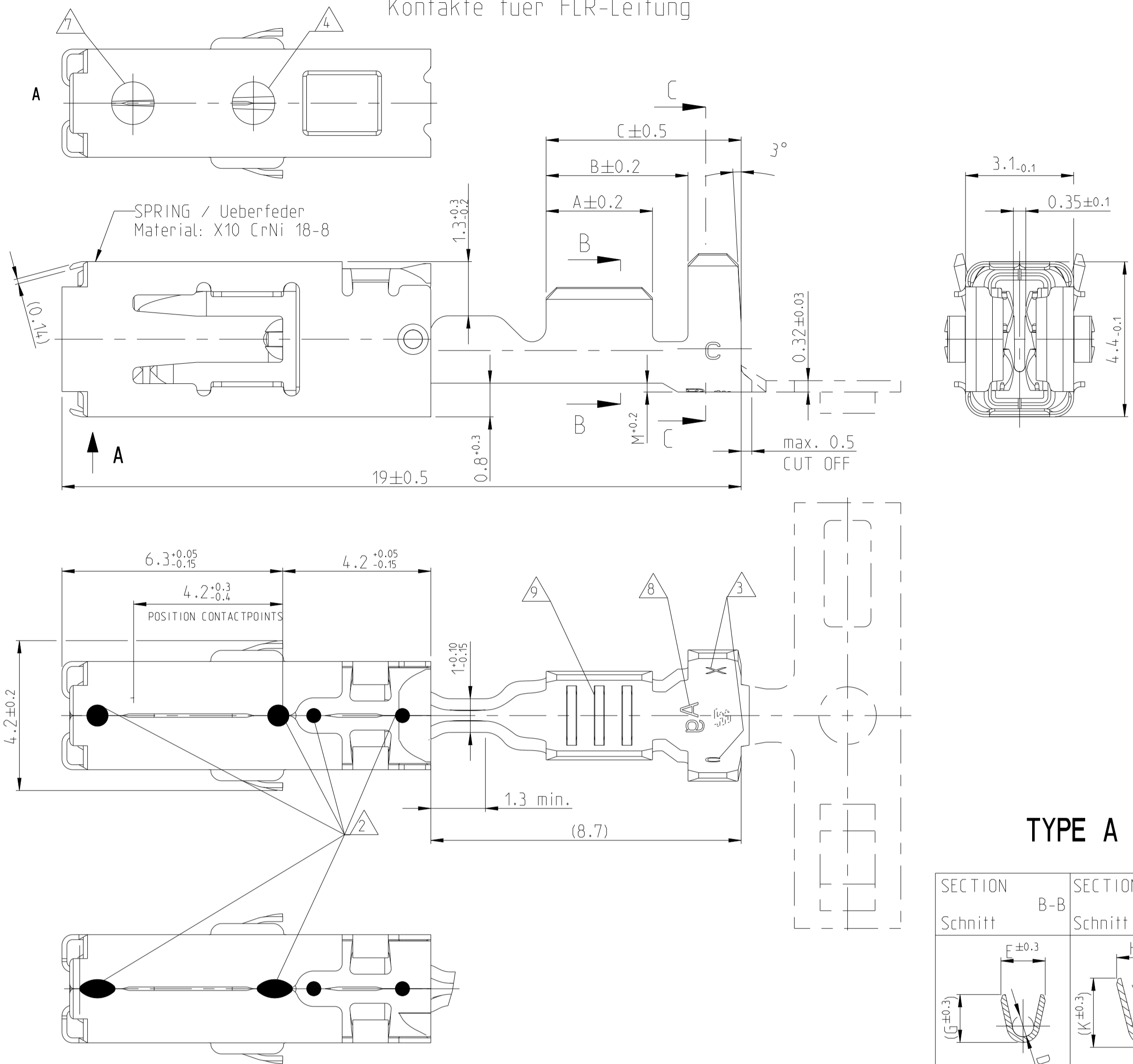

TYPE B1

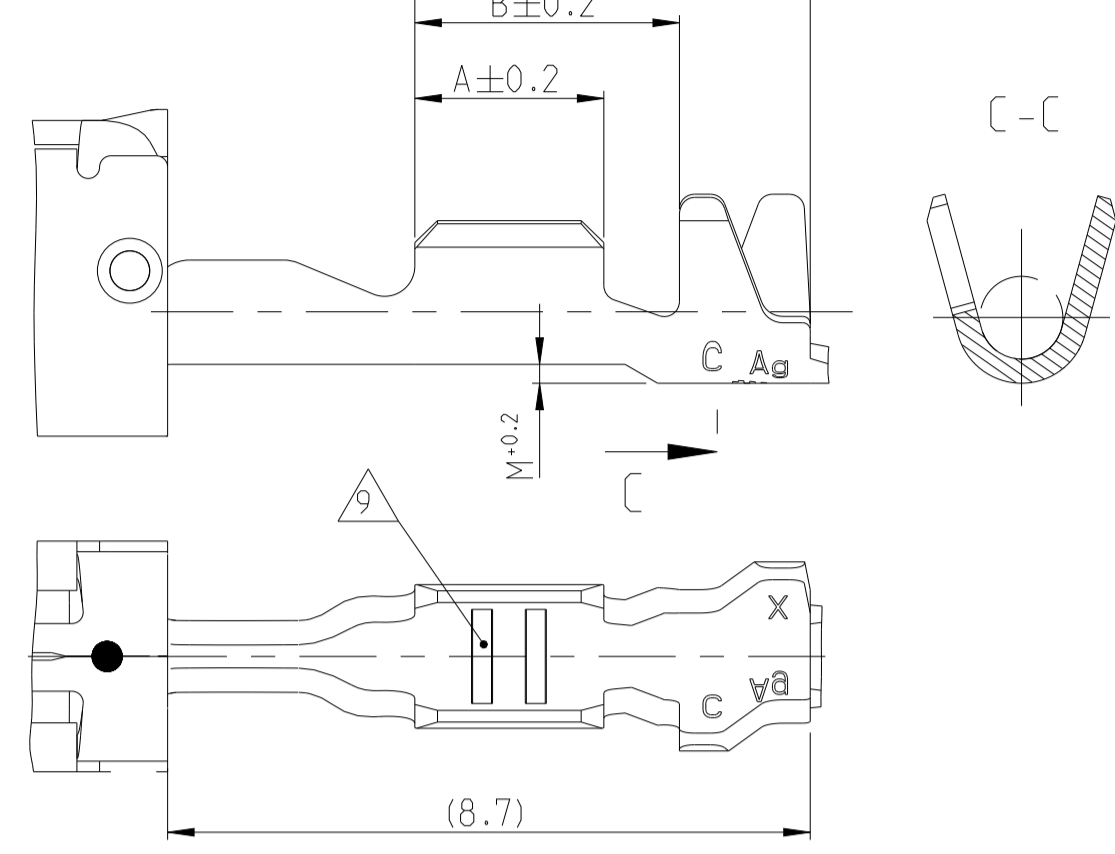

TYPE B2

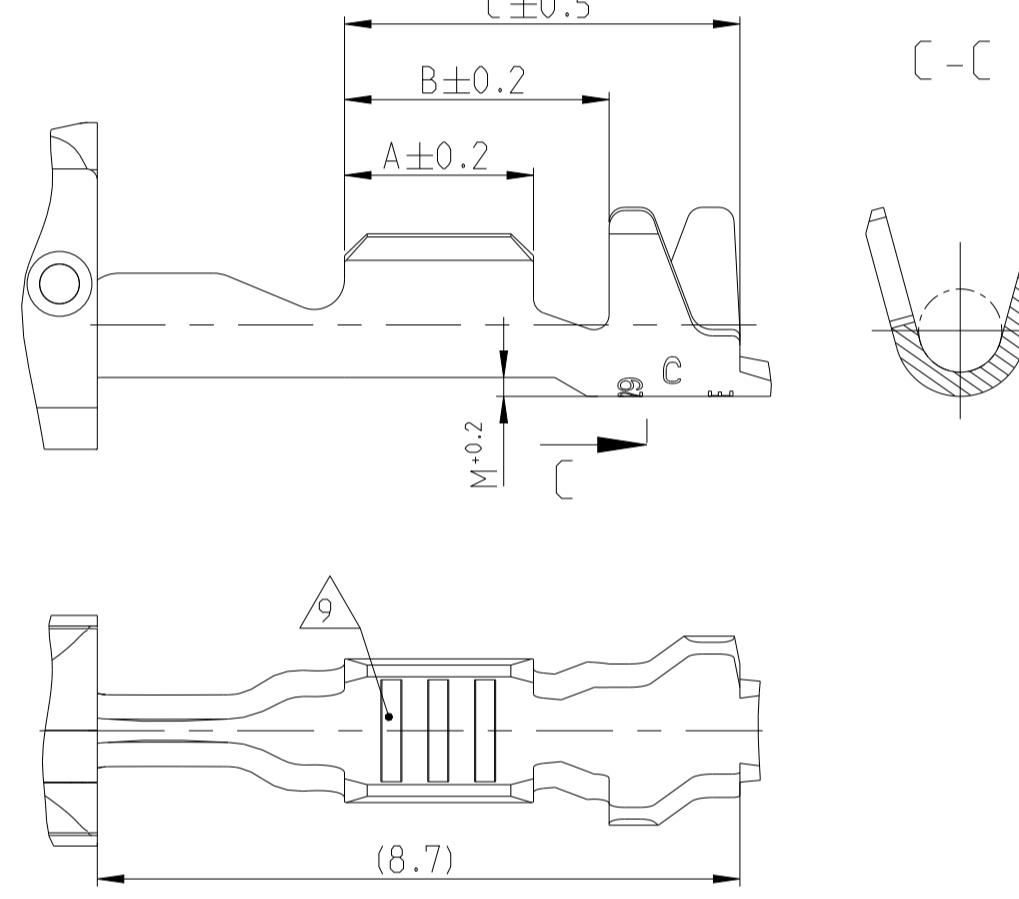

TYPE A

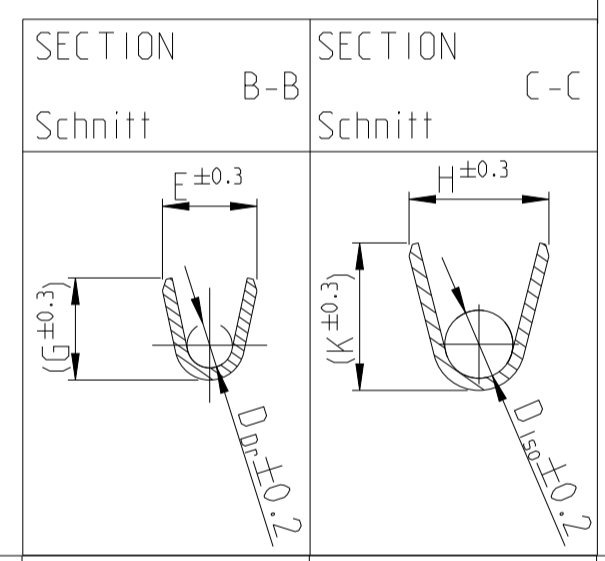

CONTACTS FOR SINGLE WIRE SEALING SYSTEM:
FLR- AND FLK- CABLE
Kontakte fuer Einzel-Dichtung-System:
FLR- und FLK-Leitung

DIMENSIONS SEE FIGURE "CONTACTS FOR FLR-CABLE"
Masse siehe Darstellung der Kontakte fuer FLR-Leitung

TYPE C1

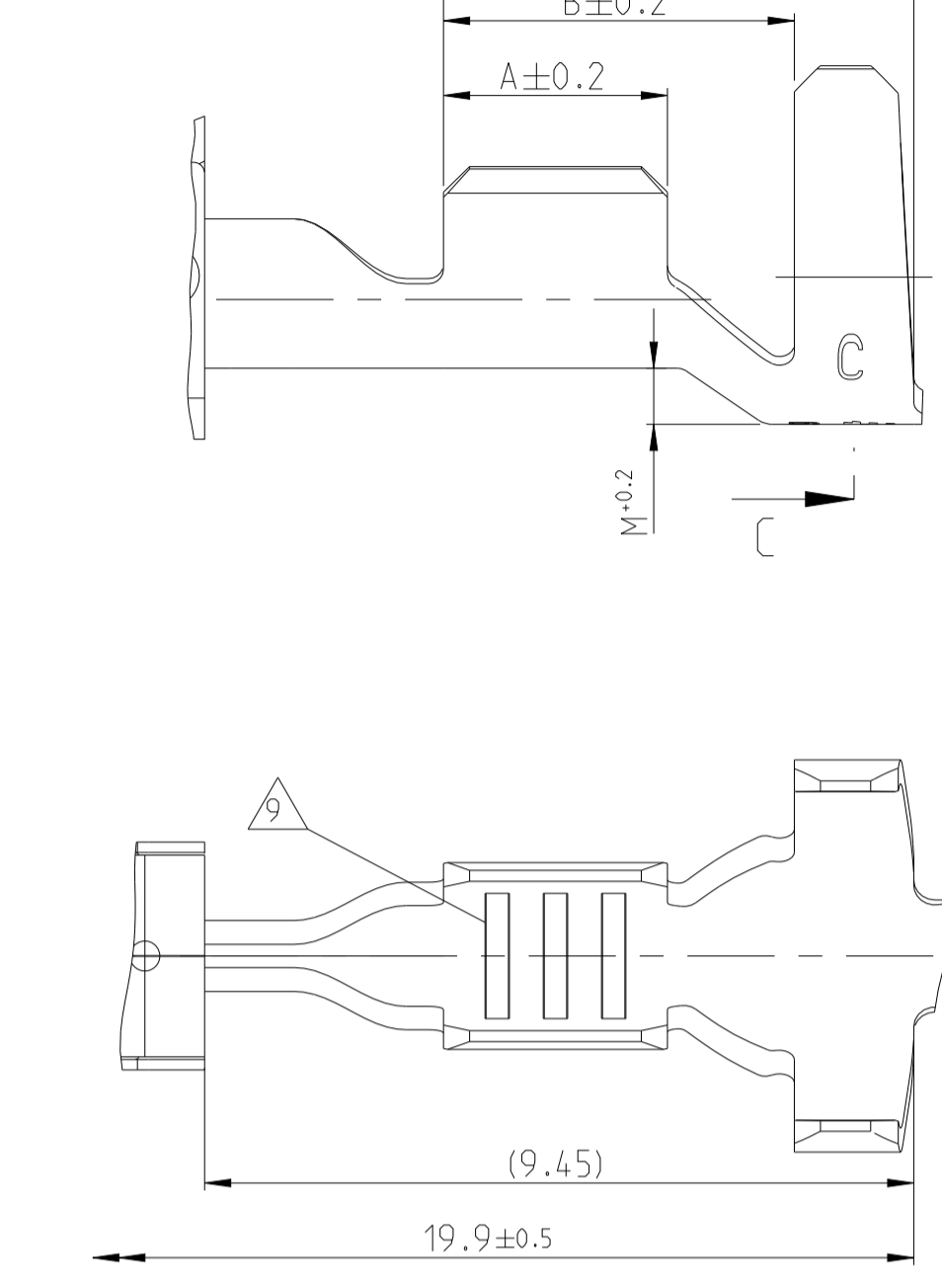

TYPE C2

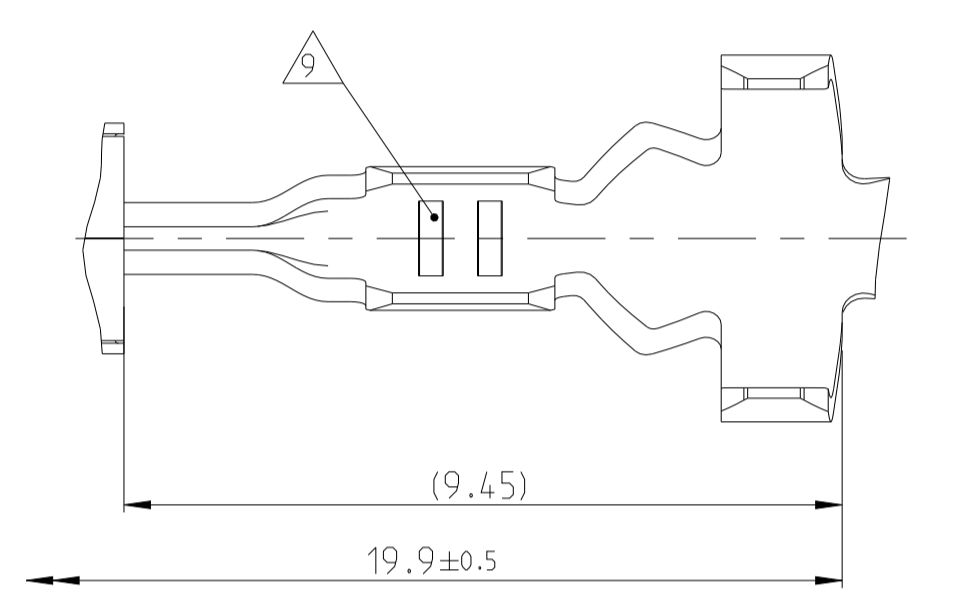

SINGLE WIRE SEALING SYSTEM

ORDER NO. Bestell-Nr.	INSULATION DIA Isolations Ø	COLOUR Farbe
963292-1	2.7...3.0	YELLOW gelb
963293-1	2.0...2.7	REDBROWN rotbraun
963294-1	1.2...2.1	BLUE blau

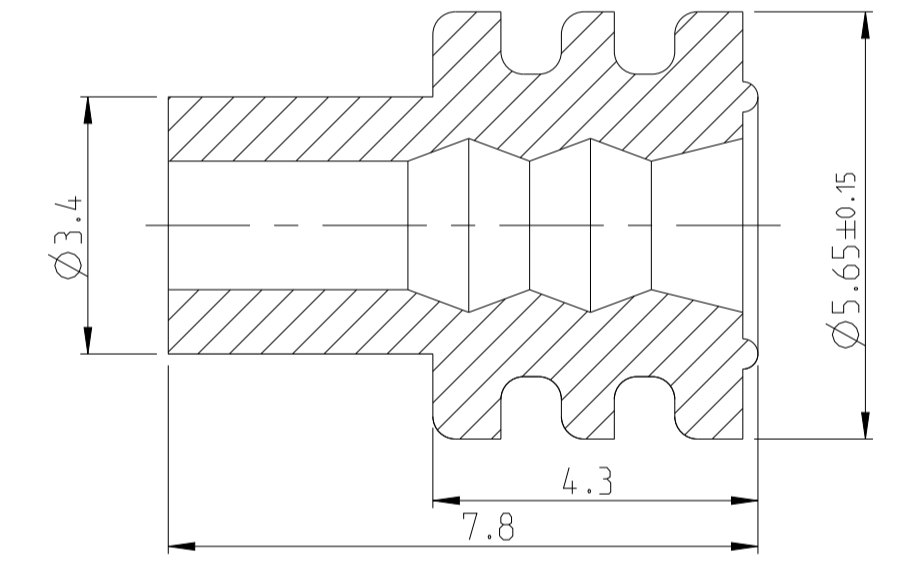

STATUS	ORDER NO. Bestell-Nr.	REV.	WIRE RANGE Drahtgroessenbereich (mm 2)	INSULATION DIA Isolations Ø (mm)	MATERIAL Werkstoff	PLATING Ueberzug	CRIMP DIMENSIONS (mm) Crimpabmessungen			FORM OF WIRE CRIMP Form des Drahtcrimp	ORDER NO. TOOL / INSERT Handzange / Matrize	ORDER NO. EXTRACTION TOOL Ausdrueckwerkzeug	CRIMP DATA AND CRIMP TOOL Crimpdaten u. Crimpwerkzeuge
							LENGTH Laenge	WIRE CRIMP Drahtcrimp	INSUL. CRIMP Isol.-Crimp				
	0-1241396-4	C	1.5-2.5	2.2-3.0	CuNiSi	SILVERPLATED versilbert	A = 3.5 B = 5.2 C = 6.8	E = 3.6 G = 3.8 D _{Dr} = 1.8	H = 5.45 K = (4.8) D _{Iso} = 3.5 M = 0.85	C1	HANDCRIMP TOOL Handcrimpwerkzeug 539635-1	SEE APPLICATION SPECIFICATION siehe Verarbeitungsspezifikation 114-18387	
	0-1241396-3	C			CuNiSi	PRESILVER vorversilbert							
	0-1241396-2	C			CuNiSi	TINPLATED versilbert							
	0-1241396-1	C	0.5-1.0	1.4-2.7	CuNiSi	PRESILVER vorversilbert	A = 3.0 B = 4.7 C = 6.3	E = 2.5 G = 2.7 D _{Dr} = 1.2	H = 5.25 K = (4.8) D _{Iso} = 3.3 M = 0.75	C1	INSERT / Matrize 539952-2		
	0-1241394-3	C			CuNiSi	TINPLATED versilbert							
	0-1241394-1	C			CuNiSi	PRESILVER vorversilbert							
Obsolete	0-1241392-3	C	0.2-0.35	1.1-1.4	CuNiSi	PRESILVER vorversilbert	A = 2.5 B = 4.7 C = 6.3	E = 1.9 G = 1.9 D _{Dr} = 0.75	H = 4.85 K = (4.4) D _{Iso} = 3.2 M = 0.7	C1	HANDCRIMP TOOL 539635-1		
Obsolete	0-1241392-2	C			CuNiSi	TINPLATED versilbert							
Obsolete	0-1241392-1	C			CuNiSi	PRESILVER vorversilbert							
	0-1564984-3	C	0.2-0.35	1.1-1.4	CuNiSi	PRESILVER vorversilbert	A = 3.3 B = 4.3 C = 5.8	E = 2.4 G = 2.3 D _{Dr} = 1.0	H = 4.7 K = (4.9) D _{Iso} = 2.6 M = 0.4	C1	INSERT 4-1579016-1		
	0-1564984-2	C			CuNiSi	TINPLATED versilbert							
	0-1564984-1	C			CuNiSi	PRESILVER vorversilbert							
	0-1241390-3	C	1.5-2.5	2.2-3.0	CuNiSi	PRESILVER vorversilbert	A = 3.0 B = 4.0 C = 5.5	E = 2.5 G = 2.7 D _{Dr} = 1.2	H = 3.7 K = (3.9) D _{Iso} = 1.8 M = 0.2	TYPE A	HANDCRIMP TOOL Handcrimpwerkzeug 539635-1		
	0-1241390-2	C			CuNiSi	TINPLATED versilbert							
	0-1241390-1	C			CuNiSi	PRESILVER vorversilbert							
	0-1241388-3	C	0.5-1.0	1.4-2.1	CuNiSi	PRESILVER vorversilbert	A = 2.5 B = 3.5 C = 5.2	E = 1.9 G = 1.9 D _{Dr} = 0.75	H = 2.5 K = (2.5) D _{Iso} = 1.1 M = 0.2	TYPE B1	HANDCRIMP TOOL 539635-1		
	0-1241388-2	C			CuNiSi	TINPLATED versilbert							
	0-1241388-1	C			CuNiSi	PRESILVER vorversilbert							
Obsolete	0-1241386-3	C	0.2-0.35	1.1-1.4	CuNiSi	PRESILVER vorversilbert	E = 2.4 G = 2.3 D _{Dr} = 1.0			TYPE B2	INSERT 4-1579016-1		
Obsolete	0-1241386-2	C			CuNiSi	TINPLATED versilbert							
Obsolete	0-1241386-1	C			CuNiSi	PRESILVER vorversilbert							
	0-1564982-3	C	0.2-0.35	1.1-1.4	CuNiSi	PRESILVER vorversilbert				TYPE B2	INSERT 4-1579016-1		
	0-1564982-2	C			CuNiSi	TINPLATED versilbert							
	0-1564982-1	C			CuNiSi	PRESILVER vorversilbert							

- Notes Bemerkungen:
- TO BE USED ON Flachstecker / TAB 2.8 ^{+0.3}/_{-0.1} 0.6 ^{-0.07}/_{-0.03}
Geeignet fuer Flachstecker / TAB 2.8 ^{+0.3}/_{-0.1} x 0.8 ±0.03
 - ALTERNATIVELY LASERWELDED POINT OR LINE SHAPED (DIE CAUSED)
Laserschweissung wahlweise Punkt- oder Linienfoermig (Fertigungsbedingt)
 - DIE-IDENTIFICATION AND REVISION STATUS
Kennung fuer Werkzeug und Revisionsstand
 - MIN. 0.8µm GOLDPLATE IN CONTACT AREA OVER MIN. 1.3µm NICKELPLATE;
MIN. 1µm TINPLATE IN CRIMP AREA.
AS INDEX SEE HOLE AT SPRING
0.8µm Goldueberzug im Kontaktbereich ueber min. 1.3µm Nickelueberzug;
min. 1µm Zinnueberzug im Crimpbereich.
Zur Kennzeichnung siehe Loch an der Ueberfeder
 - FOR DOUBLE AND SINGLE CRIMP
Fuer Doppel- und Einzelcrimp
 - SINGLE WIRE SEAL TO BE SELECTED ACCORDING TO INSULATION-DIA
Auswahl der Einzeldichtung entsprechend dem Isolationsdurchmesser
 - MANUFACTURER-CODITIONED HOLE, IS STARTING FROM REV. C AT ALL VERSIONS
Fertigungsbedingtes Loch, befindet sich ab Rev. C an allen Kontakten
 - MARKING WITH "Ag" FOR SILVERPLATE IN CONTACT AREA
Kennzeichnung mit "Ag" bei Silberueberzug im Kontaktbereich
 - DIFFERENT FORM OF THE SERRATION POSSIBLE
Unterschiedliche Ausuehrung der Rillen moeglich
 - PN 1241386 AND 1241392 NOT FOR NEW APPLICATION, REPLACED BY PN 1564982 AND PN1564984.
PN 1241386 und 1241392 nicht fuer Neuanwendung, Ersatz durch PN 1564982 und 1564984
 - DETAILS OF DESIGN ARE LEFT TO MANUFACTURER
Einzelheiten der Ausuehrung bleiben dem Hersteller uebertlassen
 - "Ag"- MARKING ON SILVER PLATED VERSIONS FOR INCREASED LIMIT TEMPERATURE
"Ag"- Markierung auf versilberten Versionen fuer erhoehte Grenztemperatur

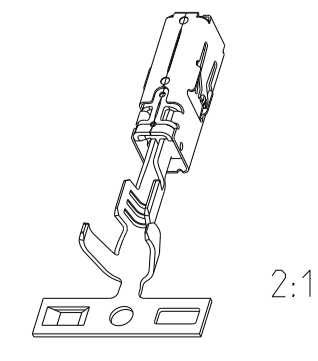

2:1

THIS DRAWING IS A CONTROLLED DOCUMENT. DIESER ZEICHNUNGSDRUCK IST EIN KONTROLLIERTES DOKUMENT. DATE: 06 JUN 2006. CHK: R. Liebing. PRODUCT SPEC: 108-18717. APPLICATION SPEC: 114-18387. MATERIAL: see table. WEIGHT: -. CUSTOMER DRAWING. /KUNDENZEICHNUNG. SCALE: 10:1. SHEET: 1 OF 1. REV: C19.

TE Connectivity
PRODUCT GROUP DRAWING FOR
AMP MCP 2.8K

SIZE: A1. CAGE CODE: 00779. DRAWING NO: 1241437. RESTRICTED TO: NUR FÜR: -. SHEET: 1 OF 1. REV: C19.