

1.0mm Pitch, Board-to-Wire LCD Interface Connectors

MDF76 Series

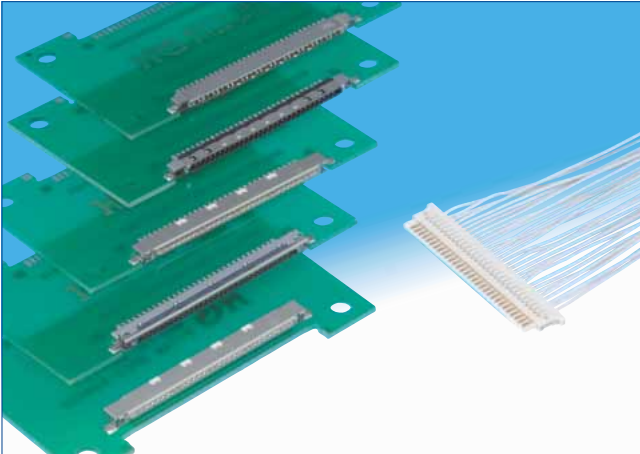

■ Increased Plug / Receptacle retention force

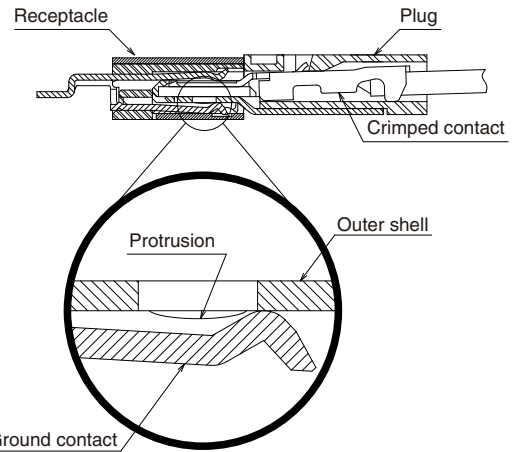

■ Features

1. High-speed data transfer

Ground contacts opposite the signal contacts (Receptacle) provide superior impedance matching.

2. EMI protection

Metal shell provides shielding and ground connections.

3. Increased Plug / Receptacle retention force

Unique configuration of the receptacle ground contacts mating with the corresponding plug increases the retention force between them.

4. Incorrect insertion prevention

Built-in polarizing features prevent reverse insertion of the plug in the receptacle.

5. High board retention force

Metal shell is soldered directly to the PC board.

6. RoHS compliant

All components and materials comply with the requirements of EU Directive 2002/95/EC.

■ Applications

Notebook computers, desktop computers, Liquid Crystal Panels, LCD monitors and other devices requiring discrete wire connections with a low-profile high performance connectors.

■ Incorrect insertion prevention

A vertically asymmetrical key form prevents reverse insertion.

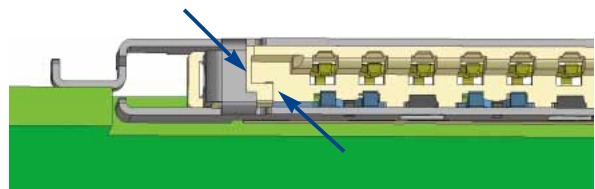

Board side receptacle

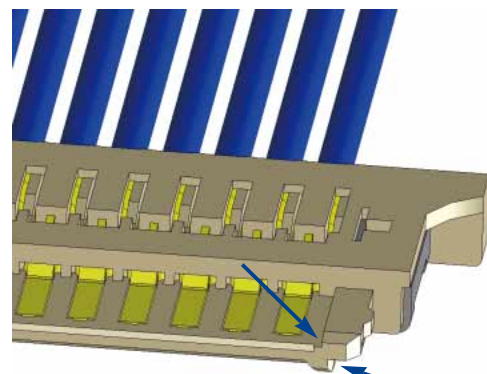

Cable side plug

Product Specifications

Ratings	Current rating (Note 1)	Wire size	28 to 30 AWG : 1.0A 32 AWG : 0.8A 36 AWG : 0.5A	Operating temperature range Operating humidity range	-40°C to +85°C (Note 2) RH 20% to 80%
	Voltage rating		200V AC	Storage temperature range Storage humidity range	-10°C to +60°C (Note 3) RH 40% to 70% (Note 3)

Item	Specification	Conditions
1. Insulation resistance	100MΩ min.	100V DC
2. Withstanding voltage	No flashover or insulation breakdown	500V AC / 1minute
3. Contact resistance	40mΩ max.	20mV max., at 1 mA.
4. Durability	Contact resistance : 80mΩ max. No deformation of components affecting performance.	50 cycles
5. Vibration	No electrical discontinuity of 1μs or longer No damage, cracks or parts dislocation.	Frequency : 10 to 55Hz, single amplitude of 0.75mm, 10 cycles in each of the 3 axial directions
6. Shock	No electrical discontinuity of 1μs or longer No damage, cracks or parts dislocation.	Acceleration of 490m/s ² , 11ms duration, sine half-wave, 3 cycles in each of the 3 axis
7. Humidity	Contact resistance : 80mΩ max., Insulation resistance : 50MΩ min.	96 hours at 60 ±2°C, and humidity of 90% to 95%
8. Temperature cycle	Contact resistance : 80mΩ max., Insulation resistance : 50MΩ min. No damage, cracks or parts dislocation.	-55°C → 5 to 35°C → 85°C → 5 to 35°C Times : 30 min. → 2 min. to 3 min. → 30 min. → 2min. to 3 min. 5 cycle
9. Resistance to soldering heat	No deformation of components affecting performance.	Reflow : At the recommended temperature profile Manual soldering : 300°C for 3 seconds

Note 1 : The current rating will differ depending on the wire size used.

Note 2 : Includes temperature rise caused by current flow.

Note 3 : The term "storage" refers to products stored for a long period prior to mounting and use.

The operating temperature and humidity range covers the non-conducting condition of connectors after board mounting and the temporary storage conditions of transportation, etc.

Material / Finish

Plug

Part	Material	Finish	Remarks
Insulator	Polyamide	Color : Beige	UL94V-0
Ground plate	Stainless steel	Tin plated	—
Crimp contact	Phosphor bronze	Gold plated	—

Receptacle

Part	Material	Finish	Remarks
Insulator	Polyamide	Color : Beige	UL94V-0
Contacts	Phosphor bronze	Gold plated	—
Ground contact	Stainless steel	Tin plated	—
Shell		Tin plated	UL94V-0

Product Number Structure

Refer to the chart below when determining the product specifications from the product number.
Please select from the product numbers listed in this catalog when placing orders.

Connector

MDF76 **#** **-** ***** **P** **-** **1** **C**
 ① ② ③ ④ ⑤ ⑥

① Series Name : MDF76	④ Connector type P : Plug S : Receptalce
② Form type Plug Blank : Standard	⑤ Contact pitch : 1mm
Receptacle (Low profile) KBW : Standard, mid-mount	⑥ Housing type C : Crimp H : Right angle SMT
③ Number of contacts : 30	

Contacts

MDF76 **-** **2836** **PCF** **A**
 ① ② ③

① Applicable conductor 2836 : 28 to 36 AWG	③ Plating A : Gold plated
② Packaging PCF : Male crimp contact / reel	

■ Plug (Discrete cable)

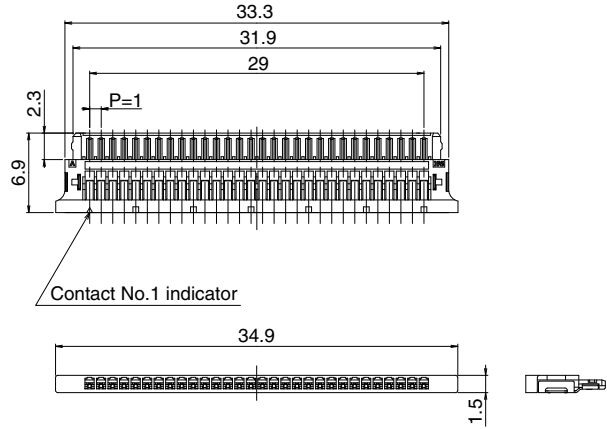

- Shown terminated
- Supplied in bag. (100 pieces/bag)
 - Contacts supplied separate

All dimensions : mm

Part No.	HRS No.	No. of contacts	Insulator Color
MDF76-30P-1C	547-0918-1	30	Beige

■ Crimp contact

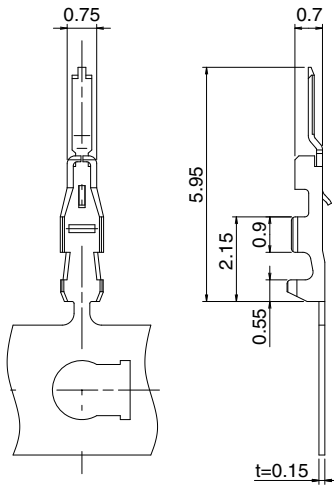

Part No.	HRS No.	Packaging	Quantity	Finish
MDF76-2836PCFA(41)	547-0919-4 41	Reel	1 Reel / 30,000	Gold plated

● Applicable wire (Tin plated annealed copper wire)

Wire size (Stranded wire conductor)	Jacket diameter
28 AWG (7 / 0.127mm)	0.6mm max.
30 AWG (7 / 0.10mm)	
32 AWG (7 / 0.08mm)	
36 AWG (7 / 0.05mm)	0.4mm max.

Note : When using other than the recommended wire, contact nearest Hirose sales representative.

● Tools

Type	Part No.	HRS No.
Applicator	AP105-MDF76-2836P	901-4613-1
Press	CM-105C	901-0001-0
Extraction tool	DF-C-PO(B)	550-0179-2

All dimensions : mm

■ Receptacles (Low profile)

- Right angle, Standard, mid-mount, SMT

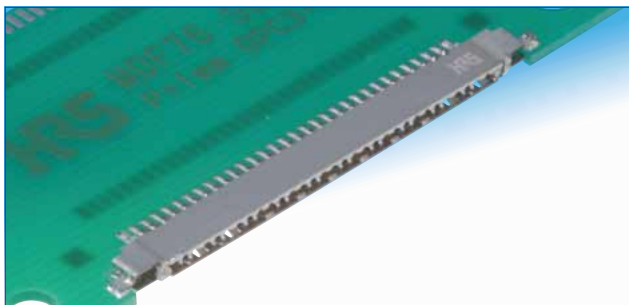

Gold plated

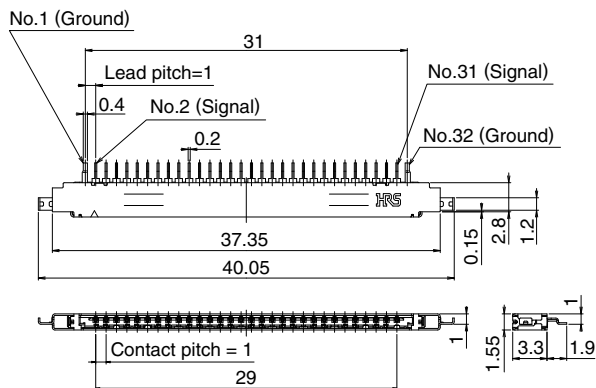

All dimensions : mm

Part No.	HRS No.	No. of contacts	Insulator Color	Packaging	Above the mounting surface
MDF76KBW-30S-1H(55)	547-0606-9 55	30	Beige	3,000 pcs. / reel	1.0mm

Recommended PCB mounting pattern

● Mid-mount

For receptacles :
MDF76KBW-30S-1H(**)

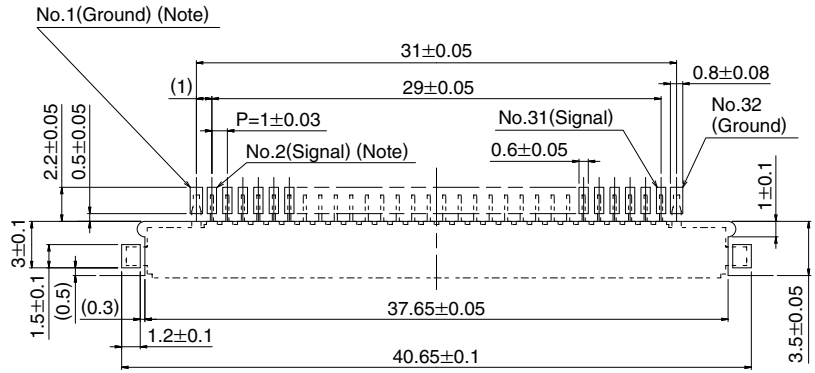

◆ Usage Recommendations

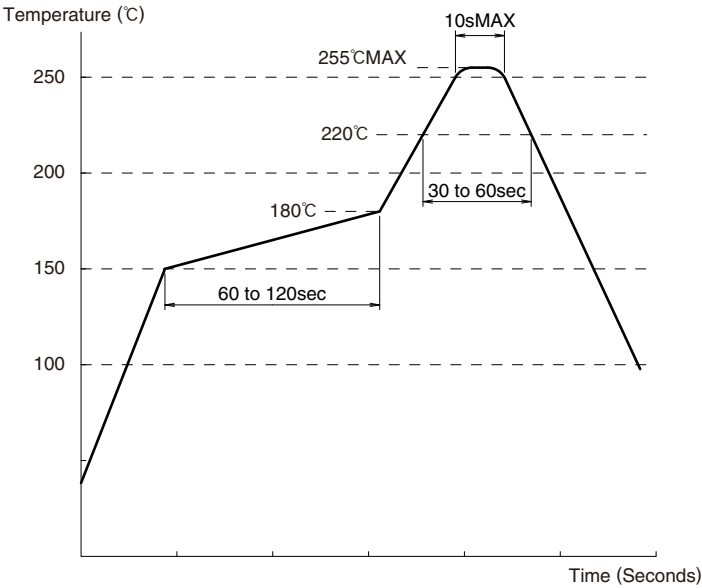
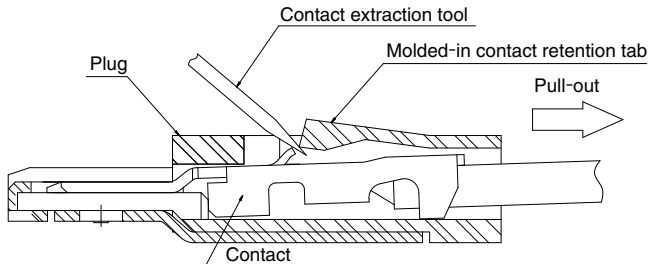
<p>1.Recommended temperature profile</p>	 <p>Note 1 : Up to 2 cycles of Reflow soldering is possible under the same conditions, provided that there is a return to normal temperature between the first and second cycle.</p> <p>Note 2 : The temperature profile indicates the board surface temperature at the point of contacts with the connector terminals.</p>
<p>2.Recommended manual soldering</p>	<p>300±10°C for 3 seconds</p>
<p>3.Recommended screen thickness and open area ratio</p>	<p>Thickness : 0.15mm Open area ratio : 100%</p>
<p>4.Board warpage</p>	<p>Maximum of 0.03mm at the connector center, with both ends of the connector as reference points.</p>
<p>5.Cleaning conditions</p>	<p>Refer to "User Guide for Wire-to-Board Connector".</p>
<p>6.Wire preparation and contact crimping</p>	<p>Refer to "User Guide for Wire-to-Board Connector". The crimp contact termination must be performed using specified tools. All dimensions and crimp conditions are listed in applicable Crimp Condition Table and Crimping Quality Standards Manual.</p>
<p>7.Crimped contact extraction</p>	<p>■ Insert the contact retention tool in the insulator body and carefully lift the molded-in retention tab while pulling on the wire at the same time (Fig. 1). Do not deflect the molded-in retention tab more than is needed to release the contact. The tab should return to its initial position after the contact is removed.</p> <p>Note : If the tab is not returning to it's initial position carefully push I back before inserting the crimped contact. Permanent breakage of the molded-in retention tab will require replacement of the entire plug.</p>  <p style="text-align: center;">Figure 1. Contact Extraction</p>

Apr.1.2026 Copyright 2026 HIROSE ELECTRIC CO., LTD. All Rights Reserved.

<p>8.Crimped contact insertion</p>	<p>Contact must be inserted horizontally oriented as shown on Fig. 2 Do NOT attempt to insert crimped contact in any other direction.</p> <div data-bbox="699 248 1406 465" data-label="Image"> </div> <p style="text-align: center;">Figure 2. Crimped Contact Insertion</p>
<p>9.Connector mating / unmating</p>	<p>Mating / unmating of the connectors should be done in the direction parallel to the receptacle's mounting surface. Do not attempt to mate/unmate in any other direction. Note : The connectors will self-guide themselves within the 20° angle, as shown in Fig. 3.</p> <div data-bbox="703 880 1396 1189" data-label="Image"> </div> <p style="text-align: center;">Figure 3. Angular mating / unmating</p>
<p>10.Precautions</p>	<p>Do not mate / unmate the connectors when the receptacle is NOT mounted on the PC board. Differences in color shade of molded components will not affect form, fit or function. Contact HRS if additional information is required.</p>

MEMO :

A series of horizontal dashed lines for taking notes.

Apr. 1. 2026 Copyright 2026 HIROSE ELECTRIC CO., LTD. All Rights Reserved.

MEMO :

A series of horizontal dashed lines for taking notes.

