

Jan.1.2026 Copyright 2026 HIROSE ELECTRIC CO., LTD. All Rights Reserved.  
In case of consideration for using Automotive equipment / device which demand high reliability, kindly contact our sales window correspondents.

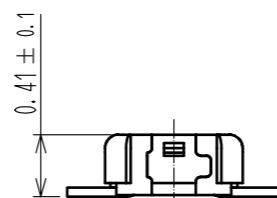

HRS DRAWING FOR REFERENCE

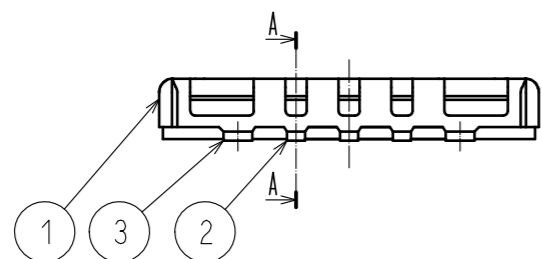
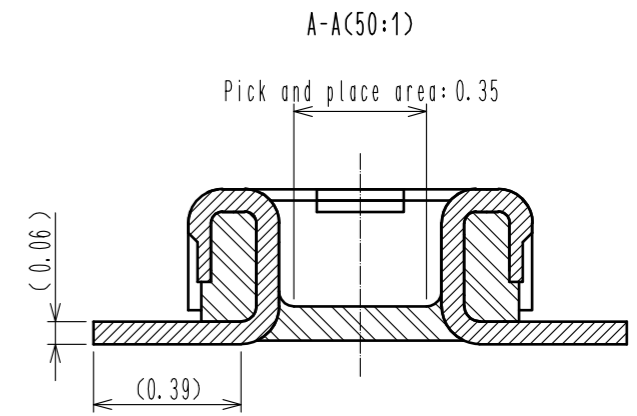
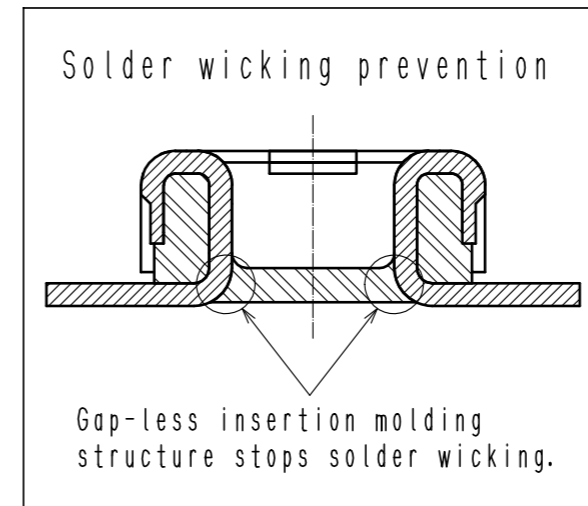
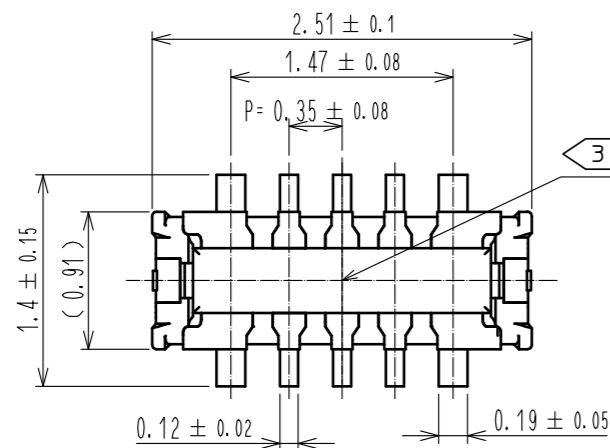
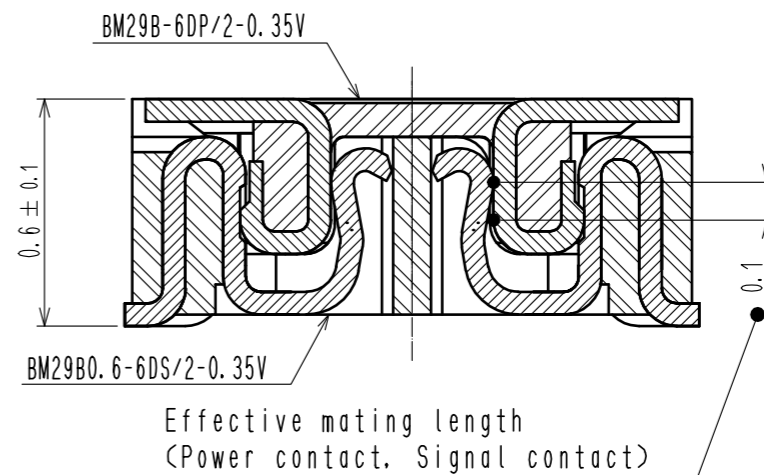

- △ NOTE 1 . All lead co-planarity will be 0.08mm MAX.  
 2 . Contact plating specifications  
 Contact area : Gold 0.05 μm MIN  
 SMT lead : Gold 0.05 μm MIN  
 Under plating : Nickel 1 μm MIN  
 (Surface : Sealing)  
 3 . Cavity number is indicated at approximate location.

3	PHOSPHOR BRONZE	2	7	PS	CLEAR. REINFORCEMENT COLLAR				
2	PHOSPHOR BRONZE	2	6	PS	BLACK. PLASTIC REEL				
1	LCP	UL94 V-0. BLACK	5	POLYESTER	CLEAR. COVER TAPE				
			4	PS	SMOKE GRAY. EMBOSSED CARRIER TAPE				
NO.	MATERIAL	FINISH . REMARKS	NO.	MATERIAL	FINISH . REMARKS				
UNITS	mm	SCALE	20 : 1	COUNT	1	DESCRIPTION OF REVISIONS	DESIGNED	CHECKED	DATE
						DIS-H-00019140	RT. OSAKI	RT. SHIMIZU	20230915
APPROVED : WR. FUKUCHI			20210423		DRAWING NO.		EDC-363653-53-01		
CHECKED : TS. MIYAZAKI			20210423		PART NO.		BM29B-6DP/2-0.35V(53)		
DESIGNED : RT. OSAKI			20210423		CODE NO.		CL0673-7004-0-53		
DRAWN : RT. OSAKI			20210423						

Jan.1.2026 Copyright 2026 HIROSE ELECTRIC CO., LTD. All Rights Reserved.  
 In case of consideration for using Automotive equipment / device which demand high reliability, kindly contact our sales window correspondents.

◆ Recommended PCB layout

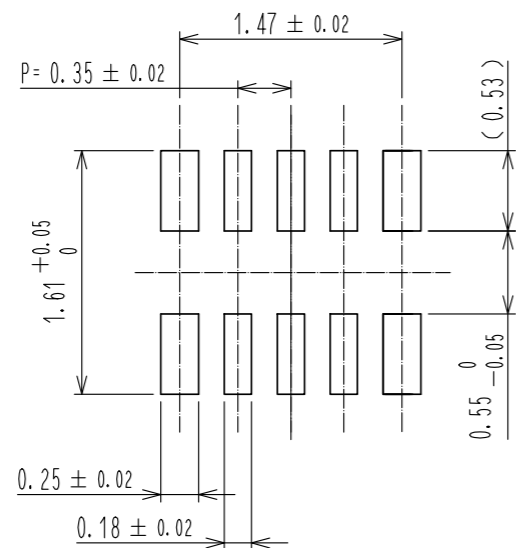

◆ Recommended metal mask dimensions  
 Metal mask thickness : 80 μm  
 (Open ratio : 80% for PCB layout)

◆ Recommended electrical circuit layout

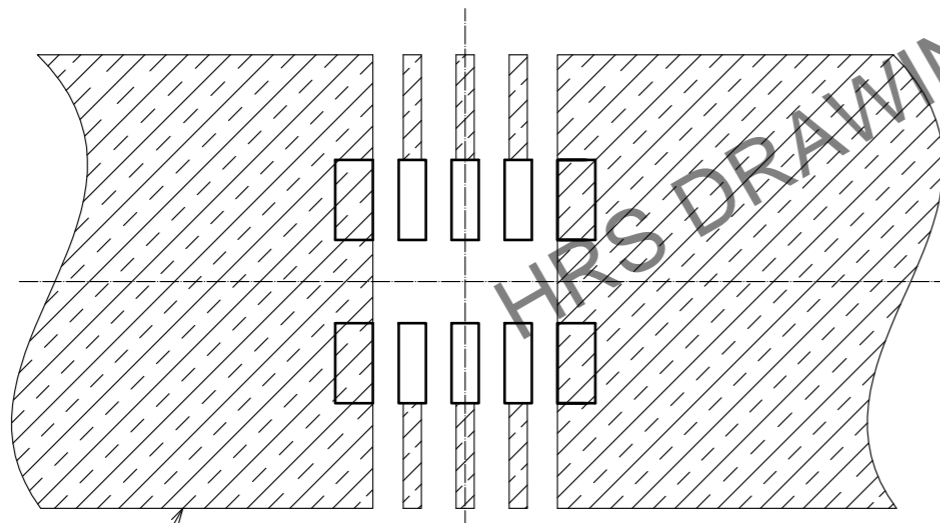

Electrical circuit

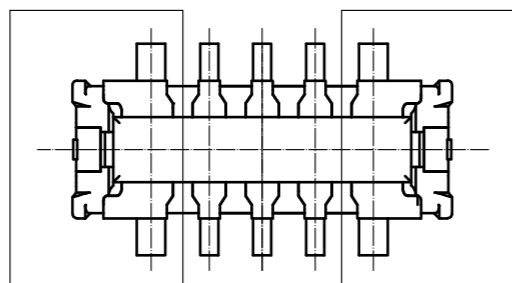

Power pin unit

4 Recommended reflow temperature profile using lead-free solder paste.

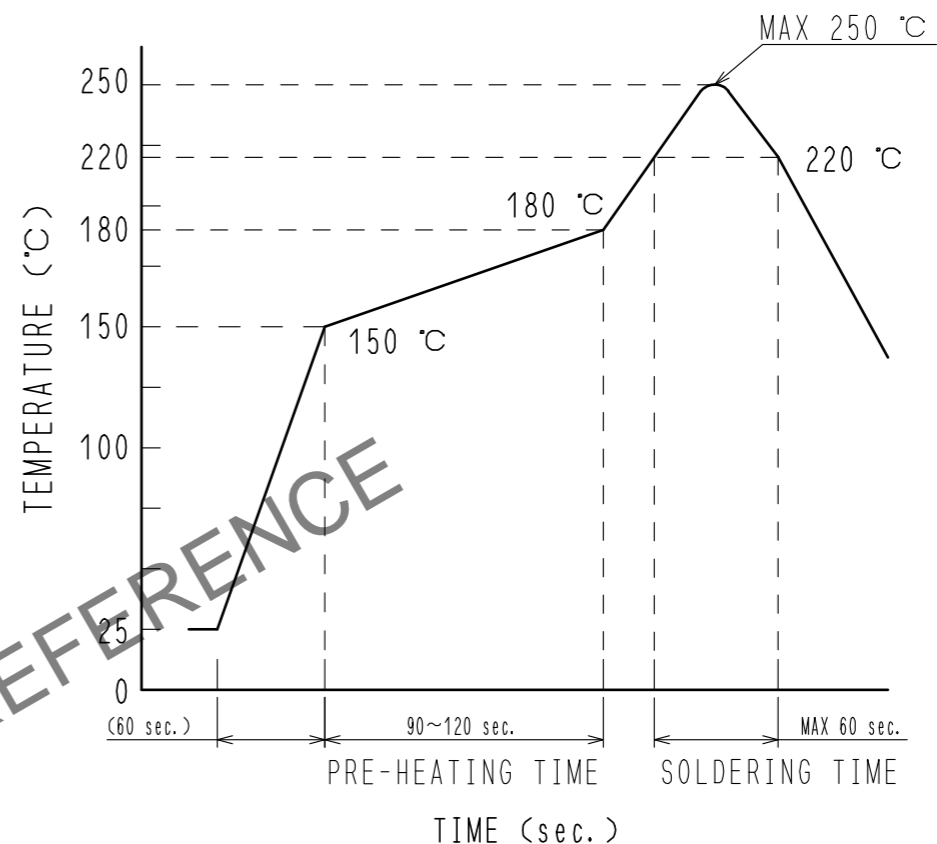

Reflow method: IR reflow  
 Number of reflow cycles: 2 cycles MAX.  
 1) Reflow time  
 Duration above 220°C: 60 sec MAX.  
 (Peak temperature: 250°C MAX)  
 2) Pre-heat time  
 Pre-heat temperature (MIN): 150°C  
 Pre-heat temperature (MAX): 180°C  
 Pre-heat time: 90-120 sec.

4 This temperature profile is based on the suggested metal mask and footprint. Please contact us if using different settings from our recommendation.

<b>HRS</b>	DRAWING NO.	EDC-363653-53-01
	PART NO.	BM29B-6DP/2-0.35V(53)
	CODE NO.	CL0673-7004-0-53
		2/4

Jan.1.2026 Copyright 2026 HIROSE ELECTRIC CO., LTD. All Rights Reserved.  
 In case of consideration for using Automotive equipment / device which demand high reliability, kindly contact our sales window correspondents.

Embossed carrier tape packaging (10:1)

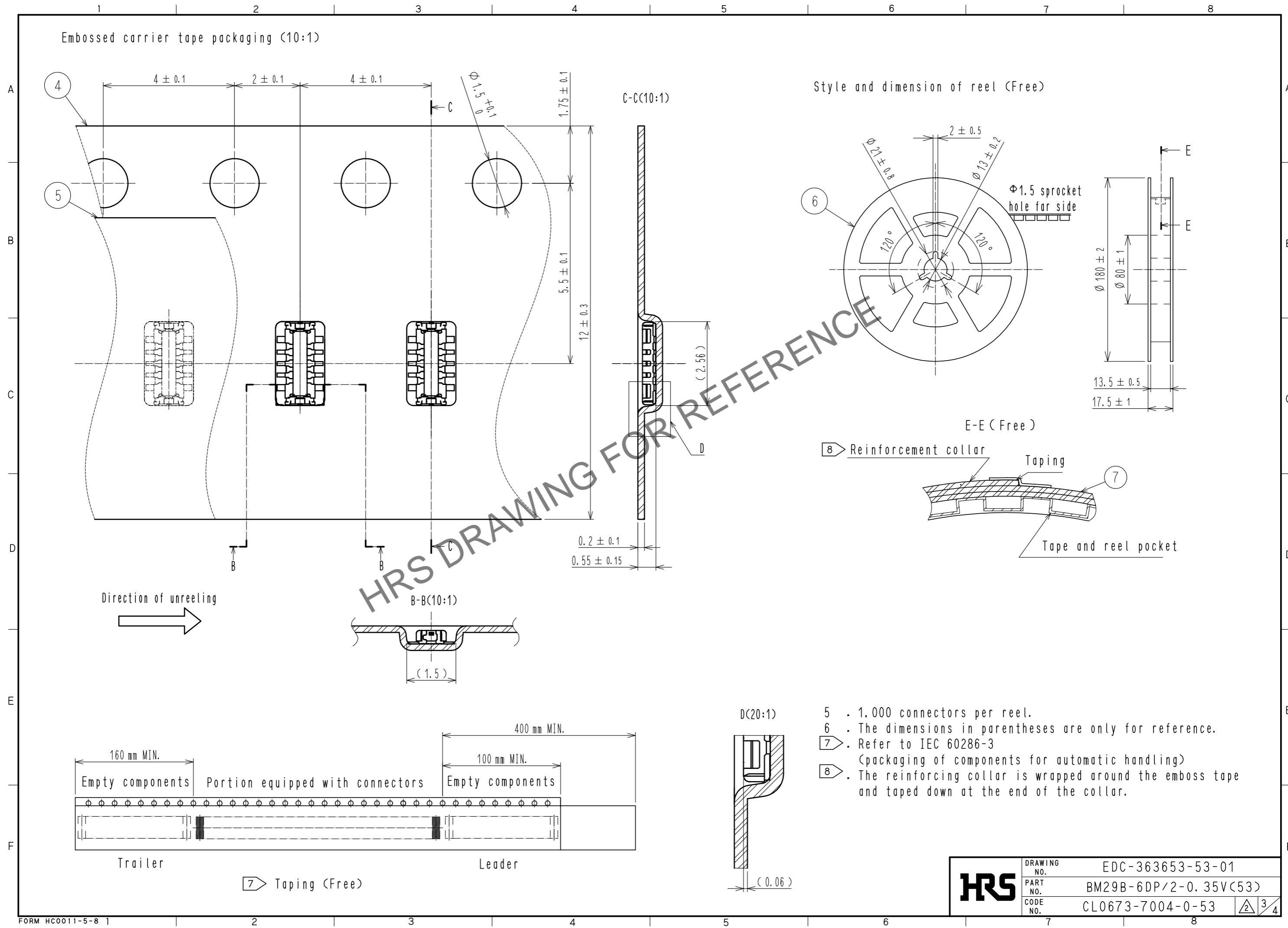

HRS DRAWING FOR REFERENCE

- 5 . 1,000 connectors per reel.
- 6 . The dimensions in parentheses are only for reference.
- 7 . Refer to IEC 60286-3  
(packaging of components for automatic handling)
- 8 . The reinforcing collar is wrapped around the emboss tape and taped down at the end of the collar.

<b>HRS</b>	DRAWING NO.	EDC-363653-53-01	
	PART NO.	BM29B-6DP/2-0.35V(53)	
	CODE NO.	CL0673-7004-0-53	3/4

Jan.1.2026 Copyright 2026 HIROSE ELECTRIC CO., LTD. All Rights Reserved.  
In case of consideration for using Automotive equipment / device which demand high reliability, kindly contact our sales window correspondents.

9. Please refer to the product guideline ETAD-H1016 for detail of connector handling.

The position between the connector and PAD

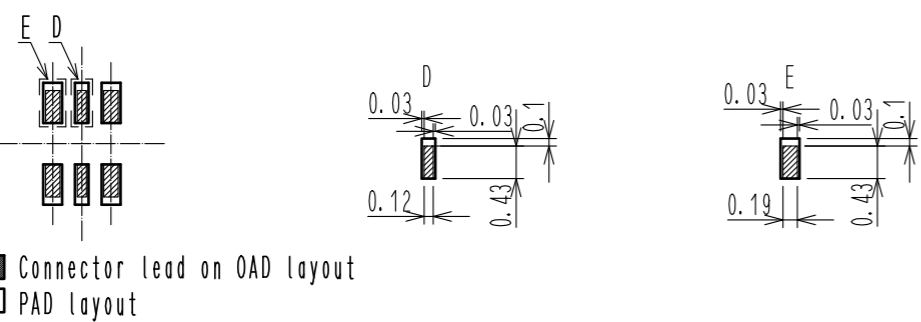

Mating method

Please mate the connector by hand.

Mating procedure

- (1) Find the alignment area to the connector in the appropriate mating position. This connector has an alignment chamber (guidance ribs) on receptacle side and "r" on plug side, so that the connector will be self-aligned. When the connector comes to the appropriate position. The connector goes into the aligned position. When aligned, it can be felt by hand.

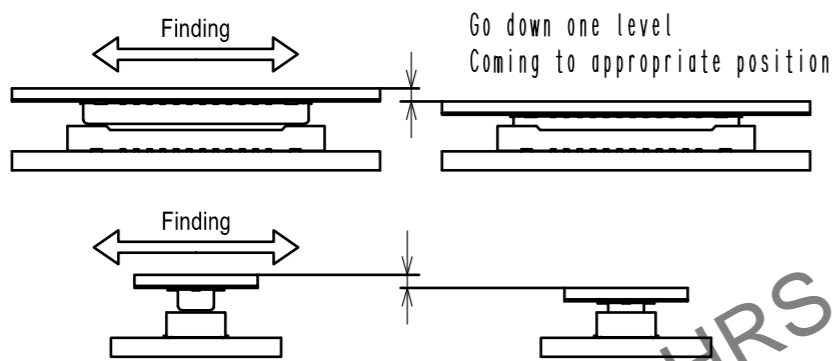

- (2) When guiding, the connectors are aligned parallel to each other, with longitudinal and lateral movements restricted. Mate them properly by applying force in this condition.



- (3) Make sure the connectors are mated correctly. If one side is floating or the connectors are mated in one direction, un-mate them once, and then mate them again, following the procedures above from the beginning.

Un-mating method

Please un-mate the connector by hand

- (1) Un-mate the connectors parallel to each other. However, if the connectors have high pin counts or thinner FPC and stiffener, it becomes more difficult to do so.

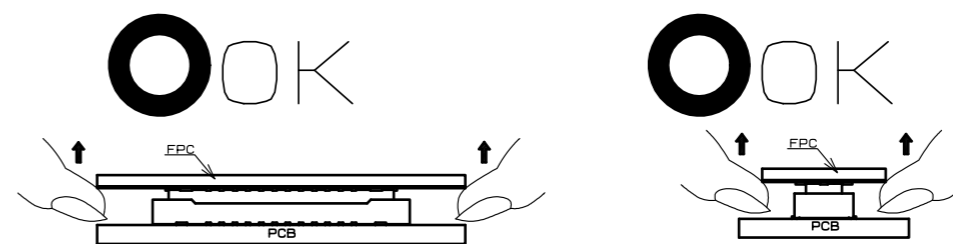

- (2) If the connector cannot be un-mated parallel it can be removed diagonally from the pitch direction. Be careful to do so since this action applies stress on the contact.

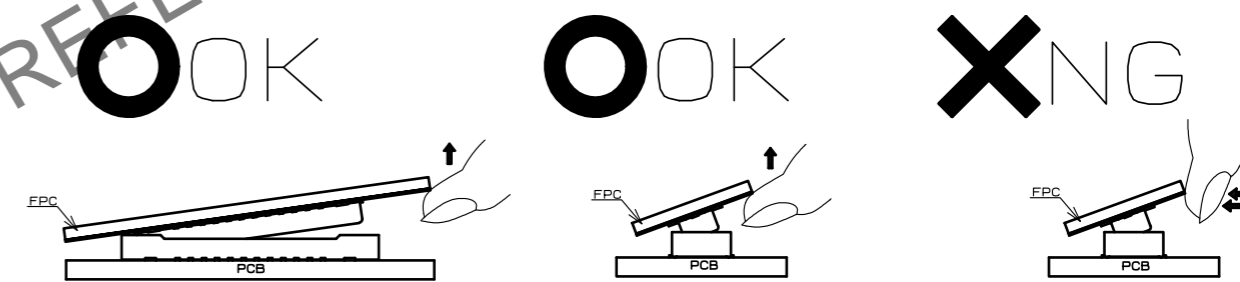

- (3) If the FPC is not rigid, The connector can be broken. Please check the action of the FPC to be used repeatedly at the time of trial production, be careful to un-mate them from the pitch direction, pulling it from the corner can also risk to putting stress on contacts.

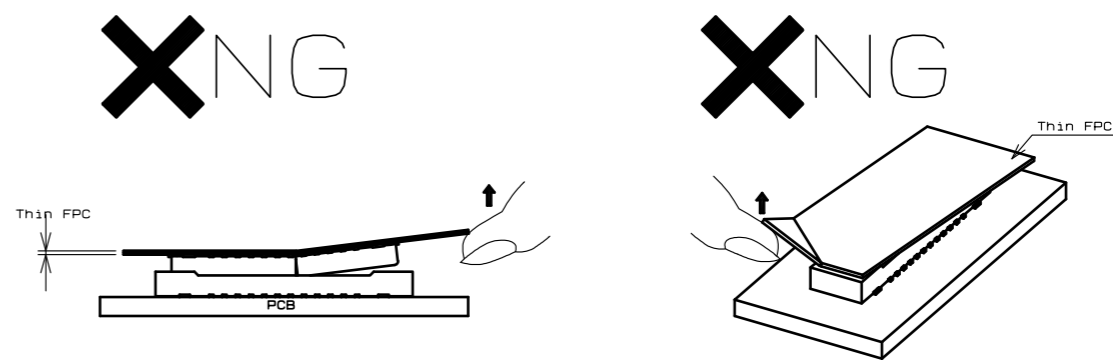

HRS DRAWING FOR REFERENCE

<b>HRS</b>	DRAWING NO.	EDC-363653-53-01	
	PART NO.	BM29B-6DP/2-0.35V(53)	
	CODE NO.	CL0673-7004-0-53	4/4