

PLASTIC R SERIES CONNECTORS

R SERIES



LEMO

Product safety notice

PLEASE READ AND FOLLOW ALL INSTRUCTIONS CAREFULLY AND CONSULT ALL RELEVANT NATIONAL AND INTERNATIONAL SAFETY REGULATIONS FOR YOUR APPLICATION. IMPROPER HANDLING, CABLE ASSEMBLY, OR WRONG USE OF CONNECTORS CAN RESULT IN HAZARDOUS SITUATIONS.

1. SHOCK AND FIRE HAZARD

Incorrect wiring, the use of damaged components, presence of foreign objects (such as metal debris), and / or residue (such as cleaning fluids), can result in short circuits, overheating, and / or risk of electric shock. Mated components should never be disconnected while live as this may result in an exposed electric arc and local overheating, resulting in possible damage to components.

2. HANDLING

Connectors and their components should be visually inspected for damage prior to installation and assembly. Suspect components should be rejected or returned to the factory for verification. Connector assembly and installation should only be carried out by properly trained personnel. Proper tools must be used during installation and / or assembly in order to obtain safe and reliable performance.





3. USE

Connectors with exposed contacts should never be live (or on the current supply side of a circuit). Under general conditions voltages above 30 VAC and 42 VDC are considered hazardous and proper measures should be taken to eliminate all risk of transmission of such voltages to any exposed metal part of the connector.

4. TEST AND OPERATING VOLTAGES

The maximum admissible operating voltage depends upon the national or international standards in force for the application in question. Air and creepage distances impact the operating voltage; reference values are indicated in the catalog however these may be influenced by PC board design and / or wiring harnesses. The test voltage indicated in the catalog is 75% of the mean breakdown voltage; the test is applied at 500 V/s and the test duration is 1 minute.

5. CE MARKING

CE marking   means that the appliance or equipment bearing it complies with the protection requirements of one or several European safety directives. CE marking   applies to complete products or equipment, **but not to electromechanical components, such as connectors.**

6. PRODUCT IMPROVEMENTS

The LEMO Group reserves the right to modify and improve to our products or specifications without providing prior notification.

7. **WARNING (Prop 65 State of California)**

Proposition 65 requires businesses to provide warnings to Californians about significant exposures to chemicals that cause cancer, birth defects or other reproductive harm. LEMO products are exempt from proposition 65 warnings because they are manufactured, marketed, and sold solely for commercial and industrial use. For further information, please visit <https://www.lemo.com/quality/LEMO-Prop-65-compliance-declaration.pdf>.

Disclaimers

LEMO works constantly to improve the quality of its products; the information and illustrations figuring in this document may therefore vary and are not binding. In any case, LEMO makes no specific warranty of merchantability, fitness for a particular purpose, third party components as such or included in assembly, non-infringement, title, accuracy, completeness, or security. The user is fully responsible for his products and applications using LEMO component.

In no event shall LEMO, its affiliates, officers, agents or employees be liable for any incidental, indirect, special or consequential damages in connection with the products or services provided by LEMO, including (without limitation) loss of profits or revenues, interruption of business, loss of use of the products or any associated equipment, materials, components or products, damages to associated equipment or in combination with other components, materials.

Reproduction of significant portions of LEMO information in LEMO data books or data sheets is permissible only if reproduction is without alteration and is accompanied by all associated warranties, conditions, limitations, and notices. LEMO is not responsible or liable for such altered documentation. Information of third parties may be subject to additional restrictions.

Table of Contents

General Production Program	page 2
Main Characteristics and Types	2
Series and Types	3
LEMO's Push-Pull Self-Latching Connection System	4
R Series Production Program	4
Series and Contact configuration	4
R Series Section	5
Interconnections	6
Model Description	6
Part Number Example	7
Part Selection Showing Internal Components	7
Housing Models	8-9
Alignment Key and Polarized Keying System	10
Crimp Contacts	11
Hybrid Overview	12
Inserts Multipole	13
Hybrid High Voltage + Low Voltage	14-15
Hybrid Coax & Low Voltage	16-17
Hybrid Fluidic & Low Voltage	18
Fluidic/Pneumatic Contacts	19-20
Housing Colors	21
Accessories	
Insulators for crimp contacts	22-23
Clamping and Bracketing	22
Inserts and Crimp contacts	23
Tooling	
Crimping tools	24-25
Positioners for crimp contact	24
Extractor for crimp contact	25
Panel Cut-Outs	
Mounting	26
PCB Drilling Pattern	
Fixed receptacle with straight print contacts	26
Technical Characteristics	
Outer Shell	27
Insulator	27
Electrical contact	28
Crimp contacts	29

General Production Program

Connectors

- Unipole from 2 to 150 Amps
- Coaxial 50 Ω and 75 Ω
- Coaxial 50 Ω (NIM-CAMAC)
- Coaxial 50 Ω for frequency \rightarrow 12 GHz
- Multicoaxial 50 and 75 Ω
- Multipole from 2 to 66 contacts
- Multipole up to 106 contacts
- High Voltage 3, 5, 8, 10, 15, 30 and 50 kV cc
- Multi High Voltage 3, 5, and 10 kV cc
- Triaxial 50 and 75 Ω
- Quadrax
- Hybrid High Voltage (HV) + Low Voltage (LV)
- Hybrid Coax + LV
- Hybrid Triax + LV
- Thermocouple
- Multithermocouple
- Fiber optic singlemode
- Fiber optic multimode
- Hybrid fiber optic + LV
- Hybrid fiber optic + coax + LV
- Fluidic
- Multifluidic
- Hybrid fluidic + LV
- Subminiature
- Miniature
- Plastic
- Printed circuit board
- Remote handling
- Watertight
- Sealed (pressure and/or vacuum)
- With plastic outer shell
- With aluminum outer shell
- With stainless steel outer shell
- With special radiation resistant insulator material
- With screw thread coupling for very high pressure
- With microswitch

Patch Panels

- For audio-mono applications: triax
- For audio-mono applications: 3 contacts
- For audio-stereo applications: quadrax
- For audio-stereo applications: 6 contacts
- For video applications: coax 75 Ω
- For video HDTV applications: 3 coax 75 Ω + 2LV

Patch Panels For fiber optic applications

Adapters For BNC, C, UHF, N, CINCH, GEN-RADIO connectors
For TNC, SMA connectors

Accessories

- Insulator for crimp contacts
- Crimp contacts
- Coaxial contacts
- Triaxial contacts
- Fiber optic contacts
- Fiber optic ferrules
- Caps
- Bend relief
- Heatshrink boot
- Insulating washers
- Double plastic panel washers
- Locking washers
- Tapered washers
- Hexagonal nuts
- Conical nuts
- Round nuts
- Notched nuts
- Earthing washers
- Lead-through with cable collet

Tooling





- Wrenches
- Assembly tool
- Pliers
- Taps
- Crimping tools
- Positioners
- Crimping dies
- Extractors
- Banding tool
- Retention testing tool for crimp contacts
- Fiber optic termination workstation
- Fiber optic polishing tools

On request

- Filtered connectors
- Connectors with special housing
- Hybrid special configuration
- Assembly onto cable

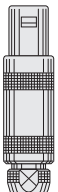
● Connectors, accessories and tools found in this catalog.

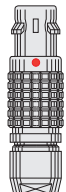
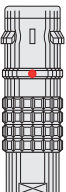
Main Characteristics and Types

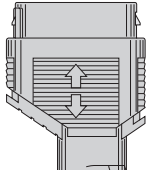
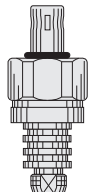
							
Series	STANDARD	WATERTIGHT	KEYED	KEYED WATERTIGHT	HARSH ENVIRONMENTS	RECTANGULAR	SCREW
	01 (Minax) 00 (NIM-CAMAC) 00 (unipole) 05 / R0 0S to 6S 0A / 4A 1D / 2C 1Y-3Y-6Y	0E to 6E 3T 4M	00 (multipole) 0B to 5B 2G / 5G	0K to 5K 2N to 5N	FF to 5F	RR / OR / 1R	03 0V to 5V 0W to 5W 2U to 5U 0M-1M-2M
Latching	Push-Pull						Screw
Key	Stepped insert (Half-Moon)		Key (G) or other key-way code		Key (N) or other key-way code	Key G or A	Key (G) or stepped insert (Half-Moon)
Shell	Metal or plastic	Metal	Metal or plastic	Metal		Plastic	Metal
Insert	Hermaphroditic or cylindrical		Cylindrical			Rectangular	Hermaphroditic or cylindrical
Contact	Solder or print		Solder, crimp or print		Crimp or print	Crimp or print	Solder (crimp or print)

Series and Types

	Series	Types																				
		Unipole	Coaxial 50 Ω	Coaxial 75 Ω	Multipole	High Voltage	Triaxial 50 Ω	Triaxial 75 Ω	Quadrax	Multi HV	Multi Coaxial	Hybrid HV+LV	Hybrid Coax+LV	Hybrid Triax+LV	Fiber Optic	Multi FO	Hybrid FO+LV	Fluidic	Multi fluidic	Hybrid fluid. +LV	Thermocouple	
Standard	01		●																			
	00	●	●				●											●				
	05					●																
	R0		●																			
	0A		●	●																		
	0S	●	●		●	●	●															●
	1S	●	●	●	●	●	●															●
	2S	●	●	●	●	●	●	●					●									●
	3S	●	●	●	●	●	●	●		●			●	●								
	4S	●	●	●	●	●	●	●		●	●		●	●								
	5S	●	●	●	●					●	●		●	●								
	6S				●						●		●	●								
	1D								●													
	2C		●		●																	
4A							●															
1Y-3Y-6Y					●																	
Watertight	0E	●	●		●	●	●															●
	1E	●	●	●	●	●	●															●
	2E	●	●	●	●	●	●					●										●
	3E	●	●	●	●	●	●		●			●	●									
	4E	●	●	●	●		●	●				●	●									
	5E	●			●				●	●		●	●									
	6E				●						●		●									
	3T			●				●														
4M						●	●															
Keyed	00				●										●							●
	0B				●										●			●				●
	1B				●							●										●
	2B				●				●	●		●	●	●			●	●				●
	3B				●					●	●	●	●	●		●	●		●	●		●
	4B				●				●	●	●	●	●	●		●	●		●	●		●
	5B				●				●	●	●	●	●	●		●	●		●	●		●
2G				●																		
5G								●														
Keyed watertight	0K				●										●			●				●
	1K				●							●										●
	2K				●					●	●	●	●	●			●					●
	3K			●	●					●	●	●	●	●		●	●		●	●		●
	4K				●				●	●	●	●	●	●		●	●		●	●		●
	5K				●				●	●	●	●	●	●		●	●		●	●		●
	FF to 5F				●																	
2N to 5N				●																		
Rectangular	RR				●								●									
	0R				●								●	●								●
	1R				●								●	●								●
Screw	03		●		●																	
	0V	●	●		●		●															●
	1V	●	●	●	●		●															●
	2V	●	●	●	●		●	●				●										●
	3V	●	●	●	●		●	●	●			●	●									
	4V	●	●	●	●		●	●				●	●									
	5V	●			●				●	●		●	●									
	0W to 5W				●					●	●	●	●	●			●					●
	2U to 5U				●										●	●	●					●
	0M to 2M				●																	

Note: ● = included in this catalog, ● = available but not included in this catalog.

LEMO's Push-Pull Self-Latching Connection System

This self-latching system is renowned worldwide for its easy and quick mating and unmating features. It provides absolute security against vibration, shock or pull on the cable, and facilitates operation in a very limited space.

The plug and the receptacle can be mated by simply pushing axially the outer shell of the plug.

Pulling on the cable or any other component of the plug than the outer release sleeve cannot break the connection.

The connector can be unmated by a single axial pull on the plug outer release sleeve.

R Series Production Program

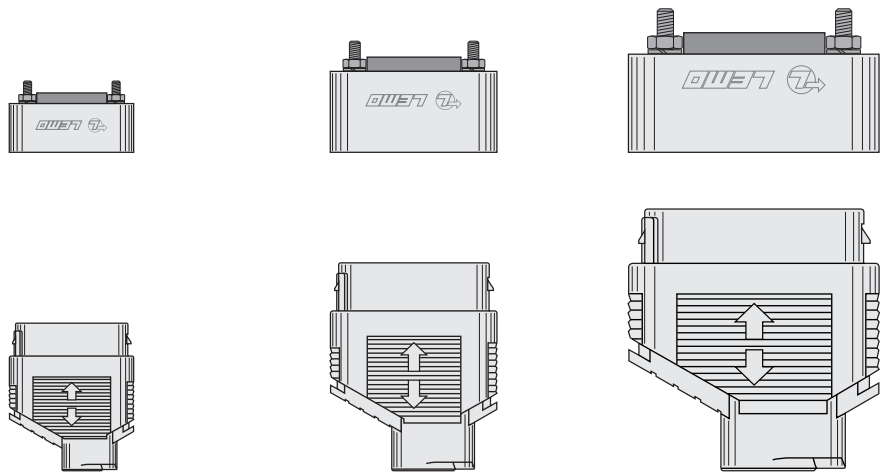

Series		RR	OR	1R
Cable \varnothing range (mm)	min.	1.0	2.4	3.7
	max.	4.0	6.2	9.2
Number of contacts (multipole)		13	10, 17, 37	28, 36, 67
Number of contacts (hybrid HV+LV)		–	4 HV + 4 LV, 2 HV + 13 LV	8 HV + 3 LV
Number of contacts (hybrid coax+LV)		1 coax + 4 LV	4 coax + 4 LV, 2 coax + 13 LV	8 coax + 3 LV
Number of contacts (hybrid fluidic+LV)		–	4 fluidic + 4 LV, 2 fluidic + 13 LV	8 fluidic + 3 LV

Note: «LV» stands for low voltage.

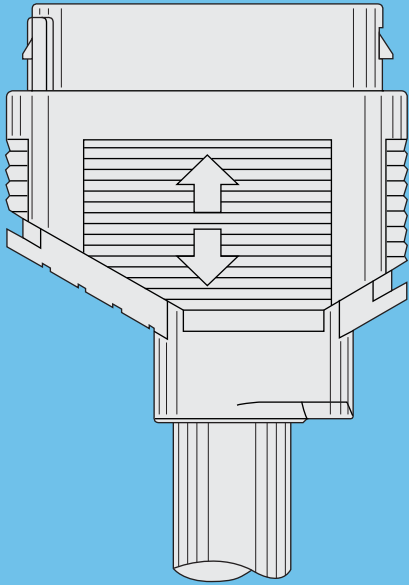
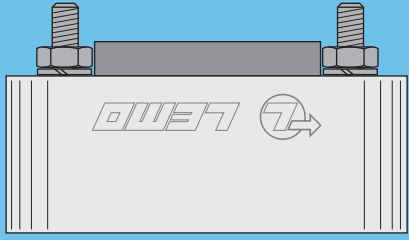

R SERIES

R Series

The R series is a rectangular connector with high pin density in a flat profile. It uses LEMO's well proven Push-Pull latching system for a smooth, hassle free connection. The ergonomic and flat profile offers high panel density, in a wide choice of colors for excellent visual aesthetics.

The R series is made of lightweight polyester resin Crastin® PBT from Dupont™. The high flexibility of its design enables various contact configuration, such as multipole, coaxial, high voltage and fluidic.

R series connectors provide the following main features:

- plastic shell for lightweight yet rugged structure
- push-pull latching enable fast and secure connections
- crimp or printed circuit contacts
- choice of 4 colors for aesthetics and quick identification
- high pin density for improved panel space
- 3 sizes and various models for design choices
- standard or hybrid pin configurations for flexibility
- thin footprint for reduced rack space and high density panel.

The R series, is initially designed to interconnect systems in medical application where aesthetics and safety is required. This connector series can also be used for test & measurement, aerospace and automotive testing, where an extensive number of contacts are needed in a limited space.

Plastic material used for manufacturing insulators is selected according to the required electric and thermal properties. The thermoplastic used is PEEK (Polyether-Etherketone) with the addition of glass fibers to improve mechanical characteristics and to increase dielectric strength.

Plastic housing models

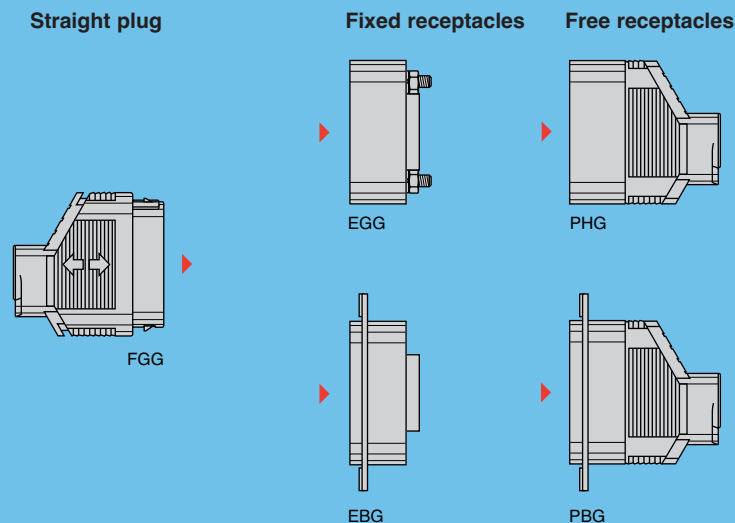

Part Numbering System

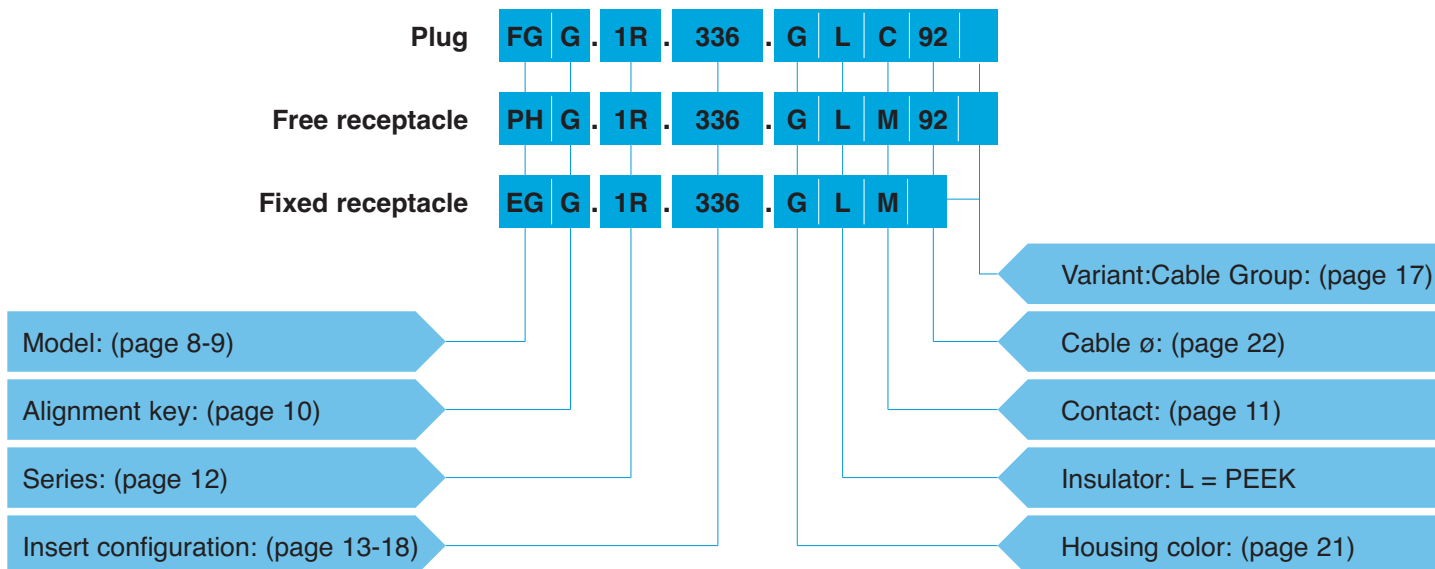

Part Number Example

Straight plug with cable collet:

FGG.1R.336.GLC92 = straight plug with key (G) and cable collet, 1R series, multipole type with 36 contacts, outer shell in gray PBT, PEEK insulator, male crimp contacts, collet for 9.2 mm maximum diameter cable.

Free receptacle:

PHG.1R.336.GLM92 = free receptacle with key (G) and cable collet, 1R series, multipole type with 36 contacts, outer shell in gray PBT, PEEK insulator, female crimp contacts, collet for 9.2 mm maximum diameter cable.

Fixed receptacle:

EGG.1R.336.GLM = fixed receptacle, nut fixing, with key (G), 1R series, multipole type with 36 contacts, outer shell in gray PBT, PEEK insulator, female crimp contacts.

Part Section Showing Internal Components

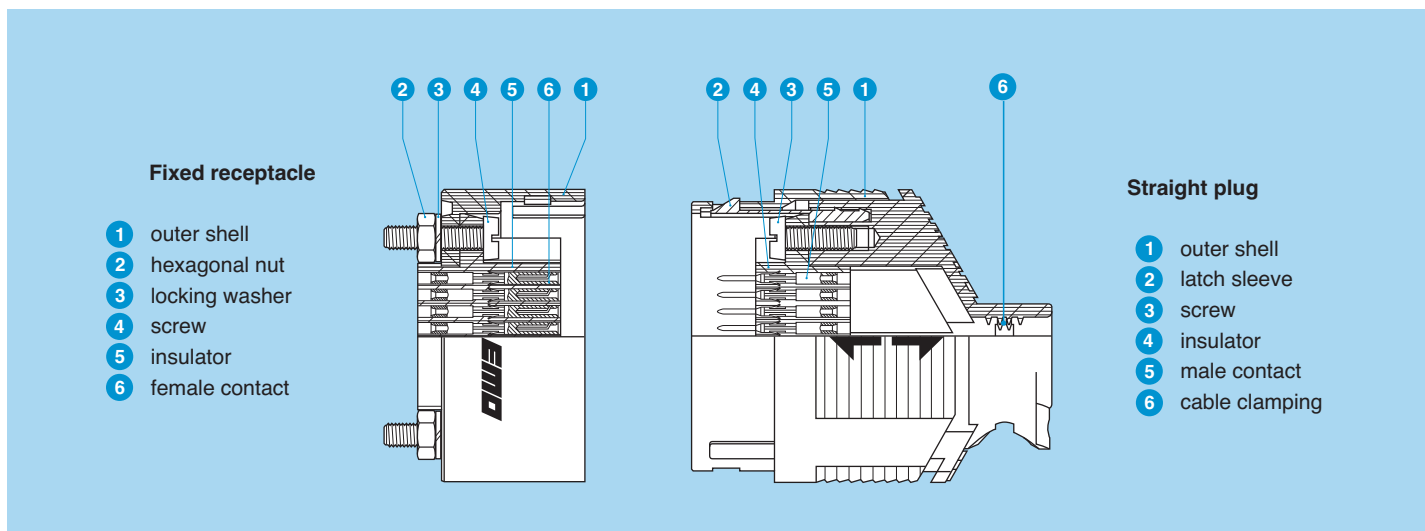



Housing models

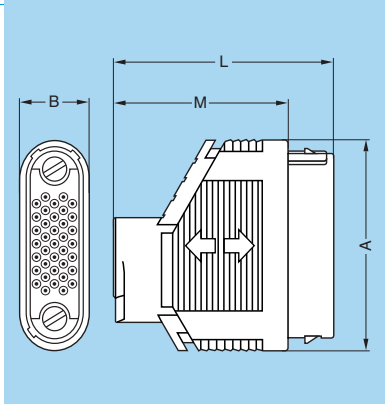

FGG Straight plug, key (G) or key (A), with cable collet

Reference		Dimensions (mm)			
Model	Series	A	B	L	M
FGG	RR	18.0	6.0	21.5	17.0
FGG	0R	24.5	9.0	30.5	23.5
FGG	1R	37.0	12.5	39.0	31.0

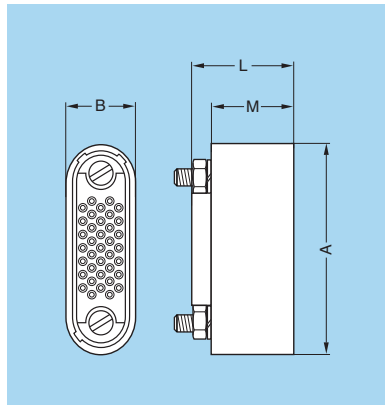

EGG Fixed receptacle, key (G) or key (A) with visible shell

Reference		Dimensions (mm)			
Model	Series	A	B	L	M
EGG	RR	18.0	6.0	12.0	7.0
EGG	0R	24.5	9.0	14.0	12.0
EGG	1R	37.0	12.5	18.0	14.5

P1 Panel cut-out page 26)

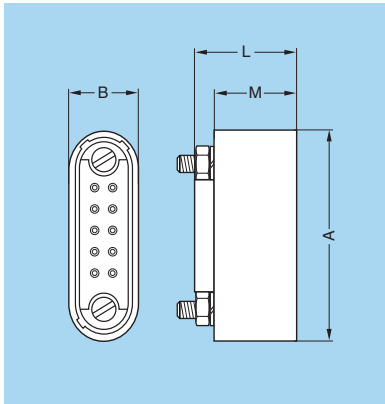
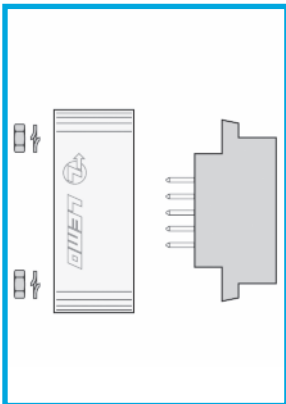

EGG Fixed receptacle, key (G) or key (A) with visible shell and contacts for printed circuit

Reference		Dimensions (mm)			
Model	Series	A	B	L	M
EGG	RR	18.0	6.0	12.0	7.0
EGG	0R	24.5	9.0	14.0	12.0
EGG	1R	37.0	12.5	18.0	14.5

P1 Panel cut-out page 26)

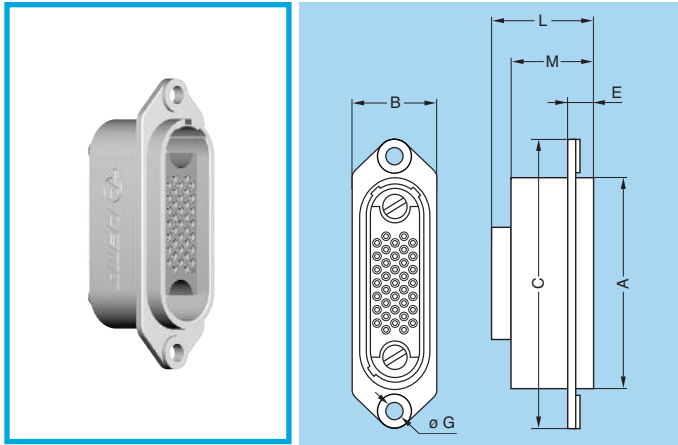

EBG Fixed receptacle, key (G) or key (A), with flange

Reference		Dimensions (mm)						
Model	Series	A	B	C	E	G	L	M
EBG	1R	37.0	15.0	51.0	4.5	3.2	19.5	14.5
EBG	0R	24.5	10.5	34	3.2	2.2	18.0	12.0

P2 Panel cut-out page 26

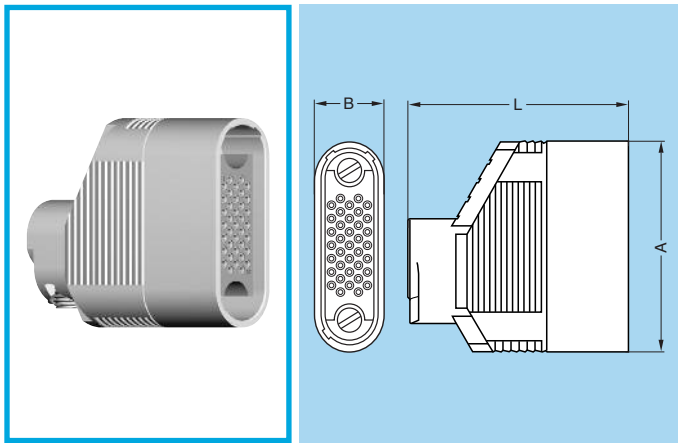

PHG Free receptacle, key (G) or key (A), with cable collet

Reference		Dimensions (mm)		
Model	Series	A	B	L
PHG	RR	18.0	6.0	22.3
PHG	0R	24.5	9.0	31.5
PHG	1R	37.0	12.5	39.0

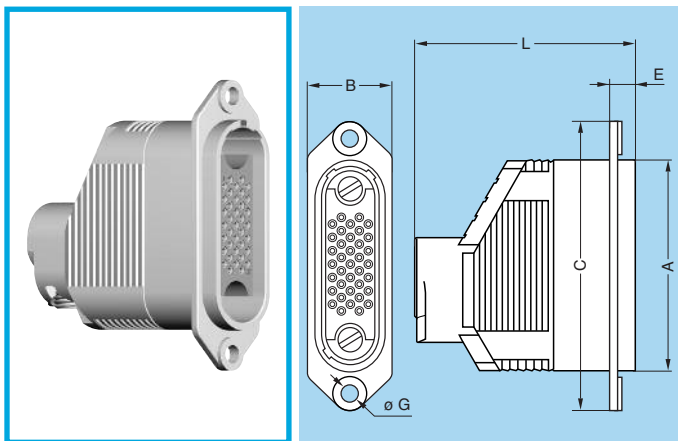

PBG Fixed receptacle, key (G) or key (A), with flange and cable collet

Reference		Dimensions (mm)						
Model	Series	A	B	C	E	G	L	
PBG	1R	37.0	15.0	51.0	4.5	3.2	39.0	
PBG	0R	24.5	10.5	34.5	3.2	2.2	31.5	

P2 Panel cut-out page 26



Alignment Key

Alignment Key and Polarized Keying System

R series connector model part numbers are composed of three letters. The LAST LETTER indicates the key position.

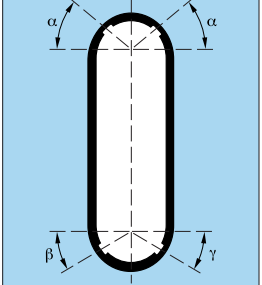
Front view of a receptacle 	Model	Nb of keys	Angles	Series			Contact type		Note
				RR	OR	1R	Plug	Receptacle	
				●●G	2	α	50°	50°	
●●A	1	β	30°	30°	30°	male	female	●	
●●A	2	α	42°	42°	42°	male	female	○	
●●A	1	γ	30°	30°	30°	male	female	○	

- First choice alternative
- Special order alternative



Crimp Contacts

Contacts for plugs, free or fixed receptacles

Ref.	Contact type	Ref.	Contact type
C	Male crimp (fig. 1) ¹⁾	P	Female crimp (fig. 2) ¹⁾
B	Male crimp (fig. 2) ¹⁾	U	Female crimp (fig. 2) ¹⁾
G	Male crimp (fig. 2) ¹⁾	N	Female straight print
M	Female crimp (fig. 1) ¹⁾		

Note: ¹⁾ there are two forms of crimp barrels. Please consult adjacent table for contact selection

Dimension of crimp barrels









Contact			Ref. contact type		Conductor			
ø A (mm)	ø C (mm)	Form per fig.	Male	Female	AWG		Section (mm ²)	
					min.	max.	min.	max.
0.5	0.45	1	C	M	32	28	0.035	0.09
					26	22	0.140	0.34
0.7	0.80	1	C	M	32	28	0.035	0.09
	0.45	2	B	P	24	20	0.250	0.50
0.9	1.10	1	C	M	26	22	0.140	0.34
	0.80	2	B	P	32	28	0.035	0.09
	0.45	2	G	U				

Contacts reference for plugs, free or fixed receptacles

Contact type	Reference		Contact			Conductor			
	Male	Female	ø A (mm)	ø C (mm)	Form per fig.	Stranded			
						AWG		Section (mm ²)	
min.	max.	min.	max.						
<p>Crimp</p>	C	M	0.5	0.45	1	32	28	0.035	0.09
	C	M	0.7	0.80	1	26	22 ¹⁾	0.140	0.34
	B	P		0.45	2	32	28	0.035	0.09
	C	M	0.9	1.10	1	24	20	0.250	0.50
	B	P		0.80	2	26	22 ¹⁾	0.140	0.34
	G	U		0.45	2	32	28	0.035	0.09
<p>Print</p>	-	N	C dimensions are detailed in the section on PCB drilling pattern. See page 26.						

Note: ¹⁾ for a given AWG, the diameter of some stranded conductor designs is larger than the crimp barrel diameter. Make sure that the maximum conductor diameter is smaller than ø C.

Hybrid Overview

Size	Ref	Number of LV Contacts	Diameter	Number of Hybrid Contact and Type	Insert
RR	804	4	0.5mm	1 coax, 50 ohm	
0R	004	4	0.7mm	4 pneumatic/fluidic 5 bars max pressure 3mm tube diameter	
0R	704	4	0.7mm	4 high voltage 2.7 kV rms (test volt) 7.5 kV dc (test volt)	
0R	804	4	0.7mm	4 coax, 50 ohms	
0R	813	13	0.7mm	2 coax, 50 ohm	
1R	003	8	0.9mm	8 pneumatic/fluidic 5 bars max pressure 3 mm tube diameter	
1R	703	3	0.9mm	8 high voltage 2.7 kV rms (test volt) 7.5 kV dc (test volt)	
1R	803	3	0.9mm	8 coax, 50 ohm	
1R	855	22 33	0.5mm 0.7mm	1 coax, 50 ohm	

Insert configuration

Multipole

	Male crimp contacts	Female crimp contacts	Reference	Number of contacts	ø A (mm)	Contact type			Crimp contact Test voltage (kV rms) ¹⁾ Contact-contact	Rated current (A) ¹⁾
						Crimp	Print (straight)	Print (elbow)		
RR			313	13	0.5	●	●	-	0.6	0.5
OR			310	10	0.9	●	●	-	1.5	3.5
			317	17	0.7	●	●	●	1.35	2.0
			337	37	0.5	●	●	-	0.6	0.5
1R			328	28	0.9	●	●	-	1.5	3.0
			336	36	0.7	●	●	-	1.5	2.5
			365	65	0.5	●	●	-	0.6	0.5
			367	67	0.5	●	●	-	0.6	0.5

www.lemo.com

13

Hybrid High Voltage + Low Voltage

		Reference	High Voltage (HV)			Low Voltage (LV)				
Male HV contacts	Female HV contacts		Number of contacts	Test voltage (kV dc)	Rated current (A)	Number of contacts	ø A (mm)	Crimp	Test voltage (kV rms) Contact-contact	Rated current (A)
0R		704	4	7.5	2.0	4	0.7	●	1.35	2.0
		713	2	7.5	2.0	13	0.7	●	1.35	3.0
1R		703	8	7.5	2.0	3	0.9	●	1.5	3.5

Plug/Receptacle includes HV contacts.

Male

FGG.0R.403.ZLME15

**HV contact
Contact HT**



Female

EGG.0R.403.ZLCE15

**HV contact
Contact HT**



Typical Assembly of High Voltage Contact

HV Contacts: Fit the HV sleeve onto the cable dielectric, check that all the HV conductor strands pass through the small hole.

Crimp the contact using tool DPC.91.701.V fitted with positioner

DCE.91.050.RVCM, set to position 3. Fit by turning the HV sub-assembly on the HV sleeve and push until it butts. The two insulators should be at the same level.

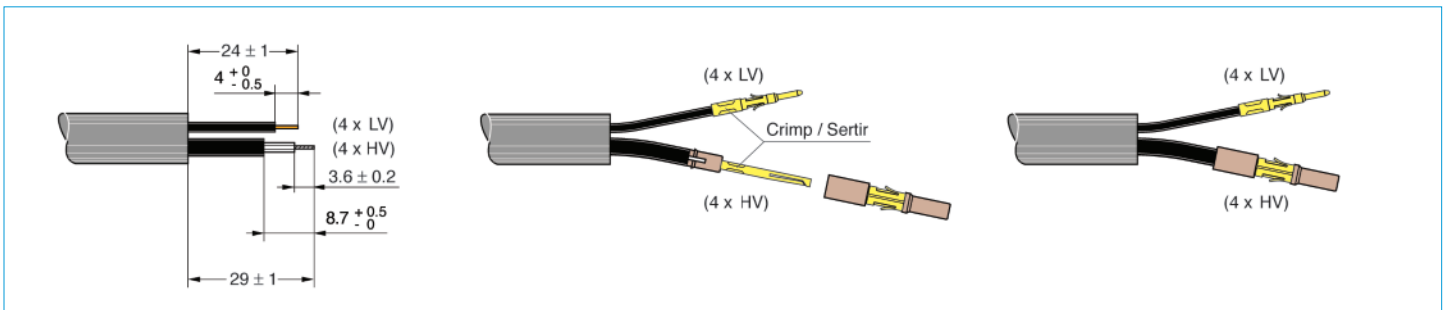

HV Contact	Conductor Range	26-28 AWG
HV Contact	Maximum Dielectric	1.5mm

Hybrid Coax + Low Voltage

		Reference	Coax				Low voltage (LV)					
Male coax contacts	Female coax contacts		Number of contacts	Impedance (Ω)	Type	Cable group	Number of contacts	ϕ A (mm)	Crimp contact	Test voltage (kV rms) ¹⁾	Rated current (A) ¹⁾	
RR			804	1	50	RR	1	4	0.5	●	0.6	0.5
OR			804	4	50	OR	1	4	0.7	●	1.35	2
			813	2	50	OR	1	13	0.7	●	1.35	2
1R			803	8	50	1R	1	3	0.9	●	1.5	3
			855	1	50	1R	1	22 33	0.5 0.7	● ●	0.6 1.35	0.5 2.0

Plug/Receptacle includes Coax contacts.

Male



Female



Typical assembly of coax contact (Coax types—RG-174/U, RG-188 A/U, RG-316/U, LMR-100A, MULTIFLEX_86) = Cable Group 1

Coax contacts: Fit the crimp ferrule onto the cable. Crimp the central contact using tool DPC.91.701.V fitted with positioner DCE.91.050.RVCM, set to position 3. Fit by turning the coax sub-assembly on the central contact until the stop is reached, check that the central contact is in the correct position in relation to the sub-assembly (0.5 mm), fold back the cable screen, place the crimp ferrule over the crimping area and complete the crimp using tool DPE.99.003.1K.

Male

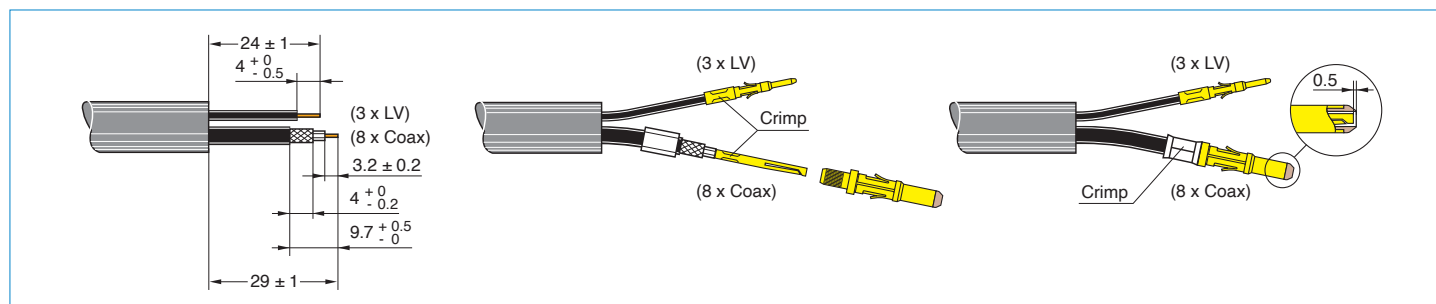

Female

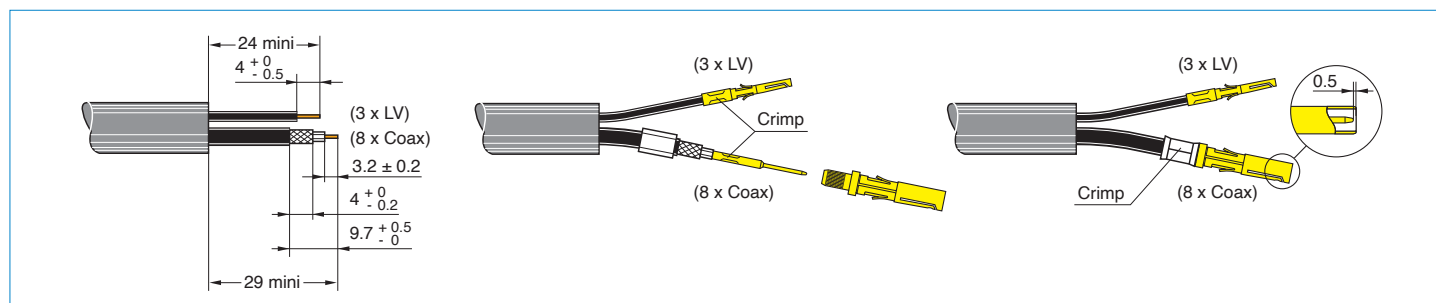

VSWR performance & recommended cable

Enable to transmit high frequency signal with low VSWR at a frequency up to 26.5 GHz when terminated with cable LMR-100A, MULTIFLEX_86 or equivalent.

Typical Performance

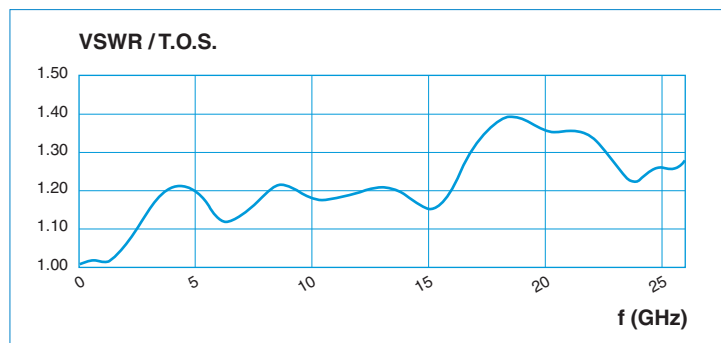

Hybrid Fluidic + Low Voltage

		Reference	Fluidic			Low voltage (LV)				
Male fluidic contacts	Female fluidic contacts		Number of contacts	Flow (l/min)	Operating pressure (bars)	Number of contacts	ø A (mm)	Crimp contact	Test voltage (kV rms) ¹⁾	Rated current (A) ¹⁾
0R		004	4	8	5	4	0.7	●	1.35	2.0
		013	2	8	5	13	0.7	●	1.35	2.0
1R		003	8	8	5	3	0.9	●	1.5	3.0

Plug includes FGG.0R.010.AZA05 (w/ valve) contacts.
 Receptacle includes EGG.0R.010.AZL05 (w/o valve) contacts.



Fluidic / Pneumatic Contacts

Fluidic / pneumatic male contact

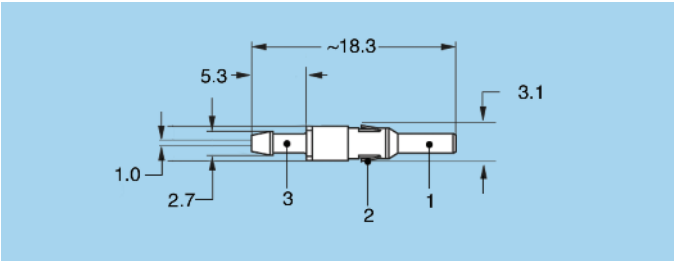

FGG.0R.010.AZA05 Male fluidic / pneumatic contact

Part number

FGG.0R.010.AZA05 (2.7mm hose barb and valve)

Note: 3 – Hose fitting/ barb, 2 – retaining clips, 1 – male sleeve

Fluidic / pneumatic male contact

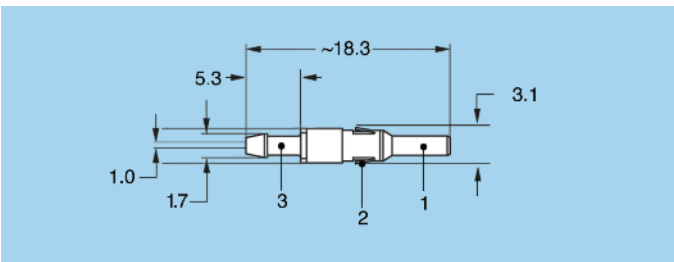
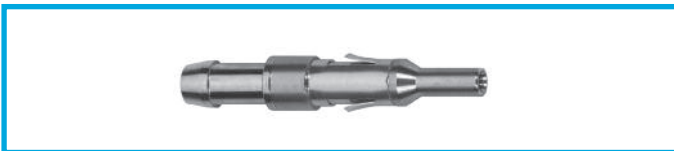

FGG.0R.010.AZL05 Male fluidic / pneumatic contact

Part number

FGG.0R.010.AZL05 (1.7mm hose barb and non-valve)

Note: 3 – Hose fitting/ barb, 2 – retaining clips, 1 – male sleeve



Fluidic / Pneumatic Contacts

Fluidic / pneumatic female contact

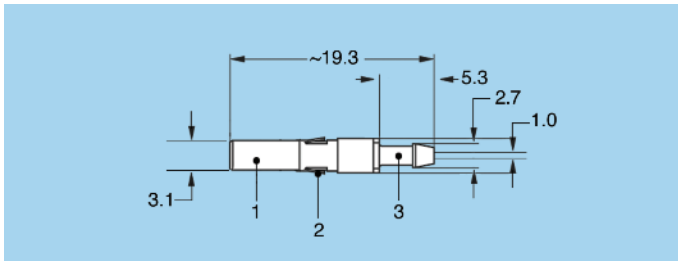
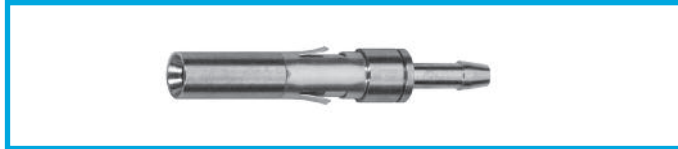

EGG.0R.010.AZA05 Female fluidic / pneumatic contact

Part number
EGG.0R.010.AZA05 (2.7mm hose barb and valve)

Note: 1 – female sleeve, 2 – retaining clips, 3 – Hose fitting/ barb,

Fluidic / pneumatic female contact

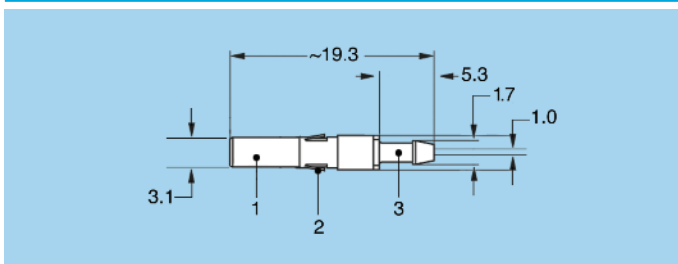
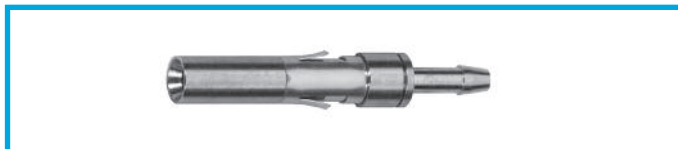

EGG.0R.010.AZL05 Female fluidic / pneumatic contact

Part number
EGG.0R.010.AZL05 (1.7mm hose barb and non-valve)

Note: 1 – female sleeve, 2 – retaining clips, 3 – Hose fitting/ barb,



Housings

Ref.	Color	RAL code
G	gray	7035
A	blue	6034
S	ochre	1028
V	green	6019

The exact color depends on manufacturing process and material pigments. For this reason some colors may differ from present RAL code.

Note: the connector shell material is Crastin® PBT.

Accessories

Collets



FGG Kit for cable clamping

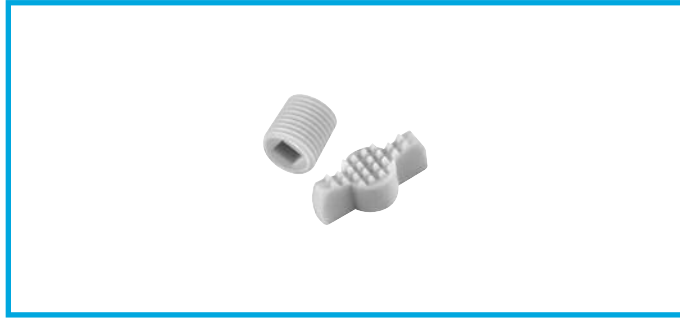

Part number	Series	Collet size	min.	max.
FGG.RR.740.IZG	RR	40	1.0	4.0
FGG.0R.762.IZG	0R	62	1.6	6.2
FGG.1R.792.IZG	1R	92	2.0	9.2

GEE Bracket

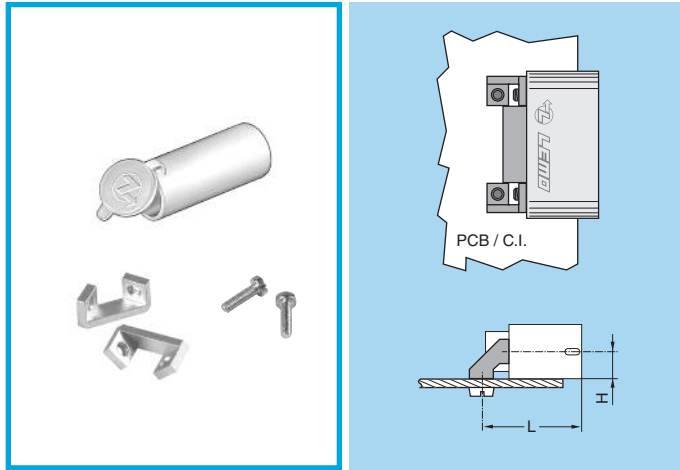

Part number	Series	Dimensions (mm)	
		L	H
GEE.RR.145.NZZ	RR	10.00	3.00
GEE.RR.146.NZZ		12.25	5.25
GEE.RR.147.NZZ		14.00	7.00
GEE.0R.145.NZZ	0R	16.50	4.50
GEE.0R.146.NZZ		18.25	6.25
GEE.0R.147.NZZ		22.50	10.50
GEE.1R.145.NZZ	1R	20.75	6.25
GEE.1R.146.NZZ		25.00	10.50
GEE.1R.147.NZZ		32.50	18.00

- Body material: Brass (UNS C 34500)
- Screws: Brass (UNS C 34500)

Spare parts



FGG-EGG Insulators for crimp contacts

	Type	Insulator part number	
		Male contact	Female contact
RR	313	FGG.RR.313.YL	EGG.RR.413.YL
OR	310	FGG.OR.310.YL	EGG.OR.410.YL
	317	FGG.OR.317.YL	EGG.OR.417.YL
	337	FGG.OR.337.YL	EGG.OR.437.YL
1R	328	FGG.1R.328.YL	EGG.1R.428.YL
	336	FGG.1R.336.YL	EGG.1R.436.YL
	365	FGG.1R.365.YL	EGG.1R.465.YL
	367	FGG.1R.367.YL	EGG.1R.467.YL

FGG-EGG Crimp contacts

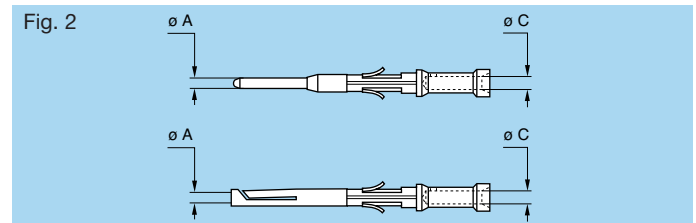
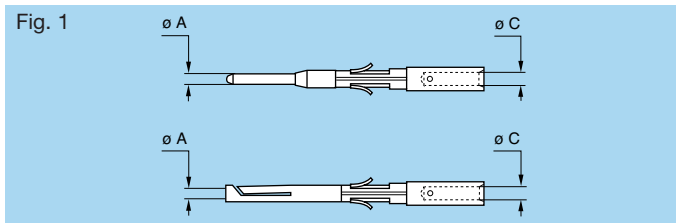

	Types	ø (mm)		Contact part number	
		ø A (mm)	ø C (mm)	Male	Female
RR	313	0.5	0.45	FGG.00.554.ZZC	EGG.00.654.ZZM
OR	310	0.9	1.10	FGG.0B.560.ZZC	EGG.0B.660.ZZM
	317	0.7	0.80	FGG.0B.555.ZZC	EGG.0B.655.ZZM
	337	0.5	0.45	FGG.00.554.ZZC	EGG.00.654.ZZM
1R	328	0.9	1.10	FGG.0B.560.ZZC	EGG.0B.660.ZZM
	336	0.7	0.80	FGG.0B.555.ZZC	EGG.0B.655.ZZM
	365/367	0.5	0.45	FGG.0B.554.ZZC	EGG.1B.654.ZZM

	Types	ø (mm)		Contact part number	
		ø A (mm)	ø C (mm)	Male	Female
OR	310	0.9	0.80	FGG.0B.561.ZZC	EGG.0B.661.ZZM
	310	0.9	0.45	FGG.0B.562.ZZC	EGG.0B.662.ZZM
	317	0.7	0.45	FGG.0B.556.ZZC	EGG.0B.656.ZZM
1R	328	0.9	0.80	FGG.0B.561.ZZC	EGG.0B.661.ZZM
	328	0.9	0.45	FGG.0B.562.ZZC	EGG.0B.662.ZZM
	336	0.7	0.45	FGG.0B.556.ZZC	EGG.0B.656.ZZM

Tooling

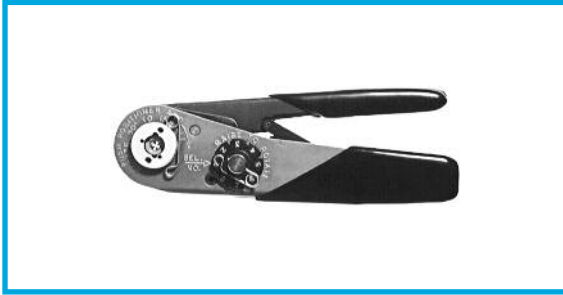

Manual crimping tools

Supplier	Part number
	contact \varnothing 0.5-0.7-0.9
LEMO	DPC.91.701.V ¹⁾
DANIELS	MH860 ¹⁾
ASTRO	616336 ¹⁾

¹⁾ According to specification MIL-C-22520/7-01.



DPE Manual crimping tool w/ die for coax contacts

Part number	Cable group
DPE.99.003.1K	1

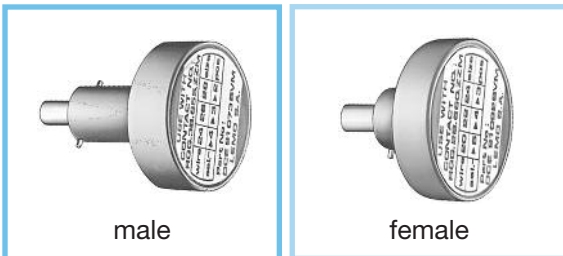

male

female

These positioners are suitable for use with both manual and pneumatic crimping tools according to the MIL-C-22520/7-01 standard.

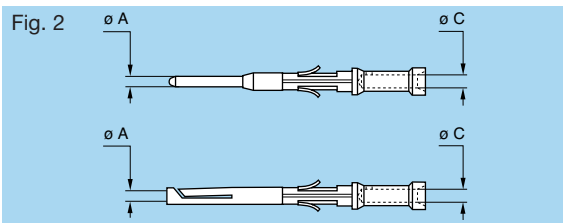
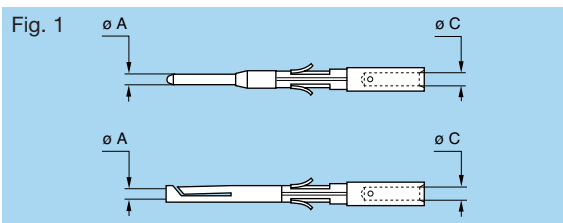

DCE Positioners for crimp contacts \varnothing 0.5-0.7 and 0.9 mm

	Connector + Contact					Positioners part number							
	Type	\varnothing A	\varnothing C	L ₁ (mm)	Conductor AWG	For male contact	For female contact						
RR	313	0.5	0.45	1	28-30-32	DCE.91.050.0VC	DCE.91.050.0VM						
						OR	310	0.9	1.10	1	20-22-24	DCE.91.090.BVC	DCE.91.090.BVM
								0.9	0.80	2	22-24-26	DCE.91.090.AVC	DCE.91.090.AVM
								0.9	0.45	2	28-30-32	DCE.91.070.BVC	DCE.91.070.BVM
317	0.7	0.80	1	22-24-26	DCE.91.070.BVC	DCE.91.070.BVM							
	0.7	0.45	2	28-30-32	DCE.91.050.0VC	DCE.91.050.0VM							
337	0.5	0.45	1	28-30-32	DCE.91.050.0VC	DCE.91.050.0VM							
1R	328	0.9	1.10	1	20-22-24	DCE.91.090.BVC	DCE.91.090.BVM						
						0.9	0.80	2	22-24-26	DCE.91.090.AVC	DCE.91.090.AVM		
										0.9	0.45	2	28-30-32
	336	0.7	0.80	1	22-24-26	DCE.91.070.BVC	DCE.91.070.BVM						
		0.7	0.45	2	28-30-32	DCE.91.050.0VC	DCE.91.051.BVM						
	365/367	0.5	0.45	1	28-30-32	DCE.91.050.BVC	DCE.91.051.BVM						

Note: a wide variation of strand number and diameter combinations are quoted as being AWG, some of which do not have a large enough cross section to guarantee a crimp as per either MIL-C-22520/1-01 or /7-01. Our technical department is at your disposal to study and propose a solution to all your applications.

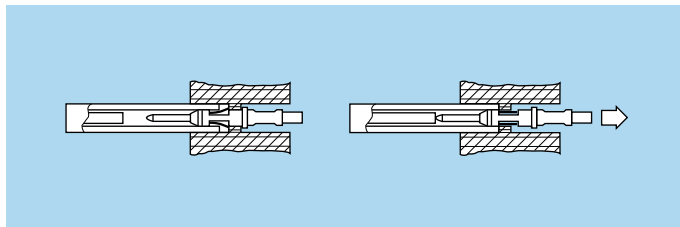
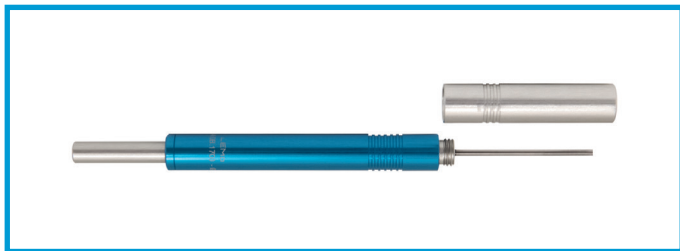

DCC Manual extractors for crimp contacts

	Connector		Extractor part number
	Type	Contact \varnothing A	
RR	313	0.5	DCC.05.02B.LAG
	310	0.9	DCC.09.05B.LAG
	317	0.7	DCC.07.04B.LAG
0R	337	0.5	DCC.05.02B.LAG
	328	0.9	DCC.09.05B.LAG
1R	336	0.7	DCC.07.04B.LAG
	365/367	0.5	DCC.05.02B.LAG

Note: this model is used for male and female contacts.

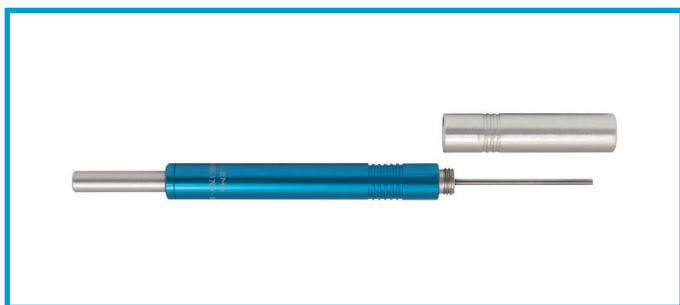

DCC Extraction tools for coax, HV or fluidic contacts

Part number	Series
DCC.91.C0R.LAG	0R-1R

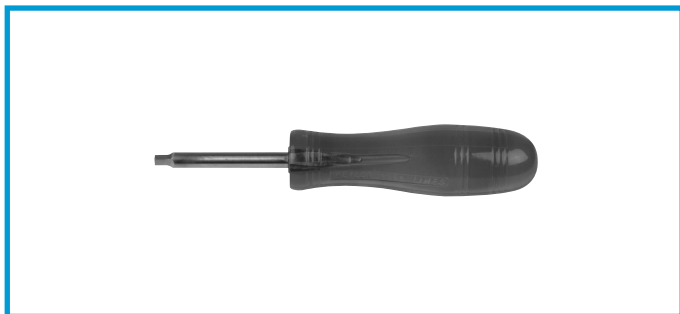

DCT Cable clamping tool

Part number	Series
DCT.91.165.PR	RR
DCT.91.205.PR	0R
DCT.91.205.PR	1R

Note: Recommended tightening torque: 0.2N.m

- Material: translucent plastic and steel



DCT Tightening tool for insulator alignment

Part number	Series
DCT.91.230.AK	RR

- Material: work tool steel

Panel cut-outs

P1 - EGG

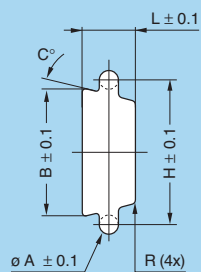

P2 - EBG, PBG

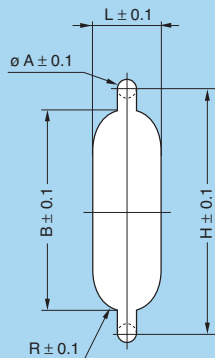

R series

Series	P1					P2					
	ø A	B	C	H	L	R	ø A	B	H	L	R
RR	1.7	7.8	5	11	3.5	-	-	-	-	-	-
OR	2.2	14.2	7	17	5.7	1.0	2.2	24.6	30	9.2	4.7
1R	3.2	22.2	10	25	8.5	1.2	3.2	37.4	45.0	12.8	6.4

PCB drilling pattern

Fixed receptacle with straight print contact (EGG models)

RR.313

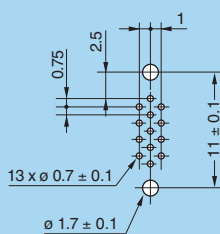

OR.310

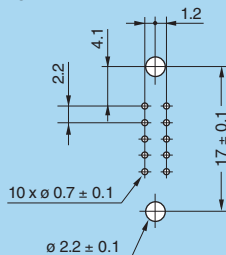

OR.317

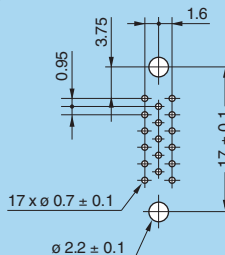

OR.337

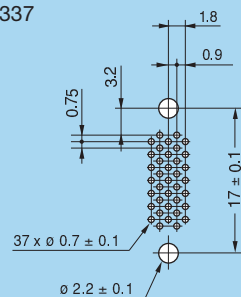

1R.328

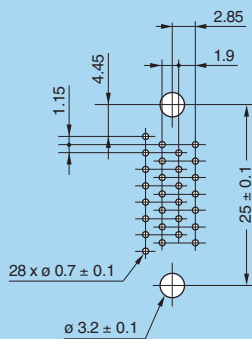

1R.336

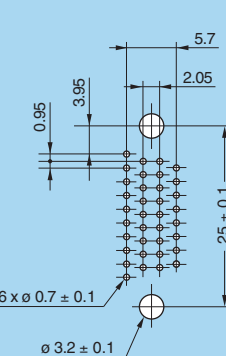

1R.365

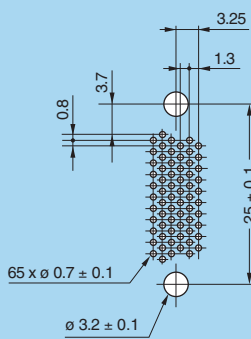

1R.367

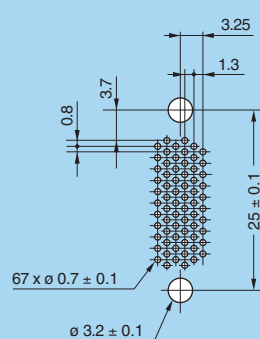

Fixed receptacle with straight print contact (EBG models)

1R.328

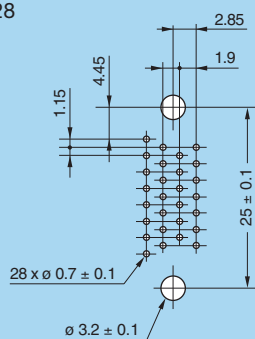

1R.336

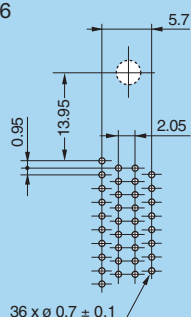

1R.365

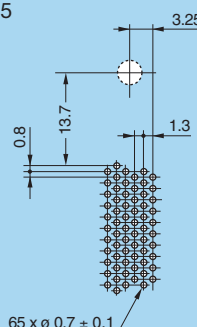

1R.855

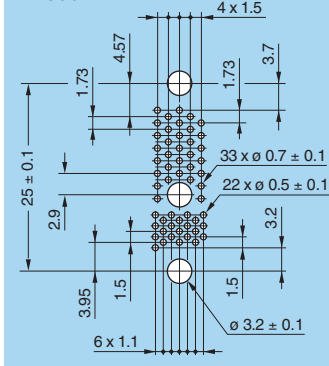

Technical characteristics

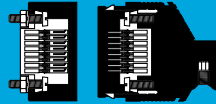

Outer shell

The R series is made of lightweight polyester resin Crastin® PBT from Dupont™ with metal latches.

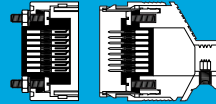

Insulator

The insulators are made of PEEK plastic. The insulators of the coax contact and the high voltage contact are Teflon™.

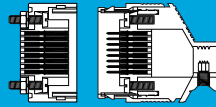

Electrical contact

Technical description

The secure reliable electromechanical connection achieved with LEMO female cylindrical contacts is mainly due to two important design features:

1. *Prod proof entry* on the mating side which ensures perfect concentric mating even with carelessly handled connectors.
2. *The pressure spring*, with good elasticity, maintains a constant even force on the male contact when mated. The leading edge of the pressure spring preserves the surface treatment (gold-plated) and prevents undue wear.

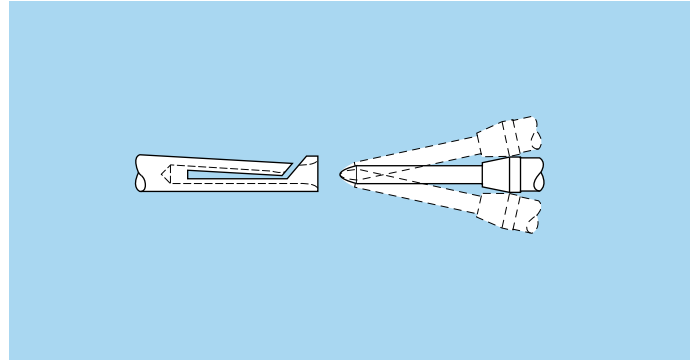

Contact material and treatment

LEMO female contacts are made of bronze beryllium (QQ-C-530) or bronze (UNS C 54400). These materials are chosen because of their high modulus of elasticity, their excellent electrical conductivity and a high mechanical strength.

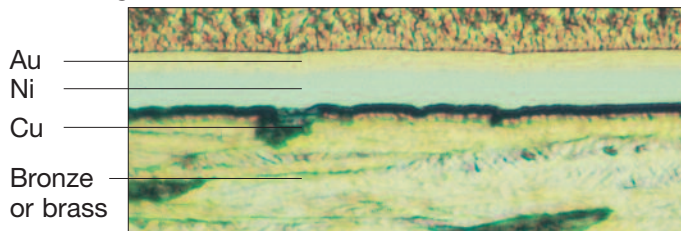

LEMO male solder and print contacts are made of brass (UNS C 38500). Male crimp contacts are made of brass (UNS C 34500) or annealed brass (UNS C 38500) with optimum hardness (HV) for crimping onto the wire.

Type	Material (standard)	Surf. treatment (µm)		
		Cu	Ni	Au ¹⁾
Male crimp	Brass (UNS C 34500)	0.5	3	1.0
	Brass (UNS C 38500)			
Male print	Brass (UNS C 38500)			
Female crimp	Bronze (UNS C 54400)	0.5	3	1.5
Female print	Cu-Be (FS QQ-C-530)			
Clips	Cu-Be (FS QQ-C-530)	-	-	-
	Stainless steel			
Wire ²⁾	Brass	-	3 ³⁾	-

Notes: the standard surface treatment are as follows:

- nickel: FS QQ-N-290A or MIL-C-26074C

- gold: ISO 4523.

¹⁾ minimum value

²⁾ for elbow print contacts

³⁾ treatment completed by 6 µm Sn-Pb tin-plating

Crimp contacts

The square form crimp method is used (MIL-C-22520F, class I, type 2) photo 1 for unipole contacts.

For multipole contacts the standard four identifier crimp method is used, MIL-C-22520F, class I, type 1), photo 2. The crimp method requires a controlled compression to obtain a symmetrical deformation of the conductor strand and of the contact material. The radial hole in the side of the contact makes it possible to check whether the conductor is correctly positioned within the contact. A good crimping is characterized by only slightly reduced conductor section and practically no gap.

For optimum crimping of bronze or brass contacts they are annealed to relieve internal stress and reduce material hardening during the crimping process. Only the crimping zone is annealed with the help of an induction heating machine designed by the LEMO Research and Development Department (see photo 3).

Advantages of crimping

- practical, quick contact fixing outside the insulator
- possible use at high temperature
- no risk of heating the insulator during the conductor-contact fixing
- high tensile strength

Crimp contacts are available in standard version (form 1) for mounting maximum size conductors. For some dimensions, these crimp contacts can be produced with reduced crimp barrels (form 2) for mounting reduced size conductors.

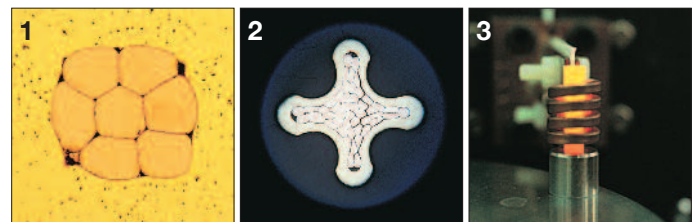

Crimp contacts

The crimp contacts can be with two forms: a standard crimp barrel for large conductors (see fig. 1) or with a reduced crimp barrel for smaller conductors (see fig. 2).

The range of cable dimensions that can be crimped into our contacts are indicated on the table on page 9.

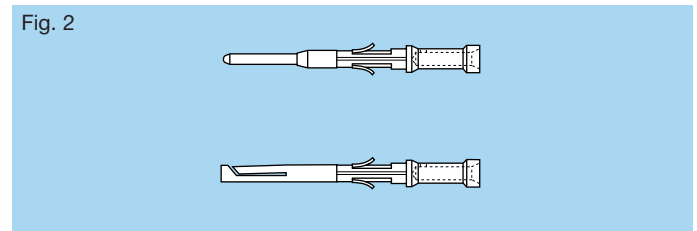
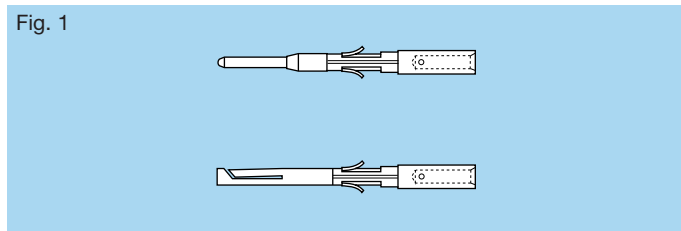



HEADQUARTERS
Switzerland

LEMO SA
Tel: +41 21 695 16 00
info@lemo.com

Subsidiaries & distributors



Online catalogue



lemo.com

