

## SFP-2.5G-FX-2KM-I

### 2.5GBase-FX SFP Transceiver

Hot Pluggable, +3.3V, Duplex LC, 1310nm, SMF, up to 2km, Industrial Temperature

#### FEATURES

- Up to 2.5Gbps data links
- 2km with 9/125µm SMF
- 1310nm DFB laser
- Duplex LC Connector
- Hot-pluggable SFP footprint
- Single 3.3V power supply
- Digital Diagnostic Monitor (DDM)
- Industrial Operating Temperature Range: -40 to 85°C
- RoHS compliant

#### APPLICATIONS

- SDH STM S-16.1, I-16
- SONET OC-48 IR-1, SR

#### DESCRIPTION

ATGBICS SFP-2.5G-FX-2KM-I is a small form factor pluggable (SFP) transceiver compatible with multi-sourcing agreement (MSA). It is suitable for single-mode fibre (SMF) communications in SDH STM S-16.1/I-16 and SONET OC-48 IR-1, SR.

## ABSOLUTE MAXIMUM RATING

Parameter	Symbol	Min.	Typical	Max.	Unit
Operating Temperature	T <sub>o</sub>	-40	-	85	°C
Storage Temperature	T <sub>s</sub>	-40	-	85	°C
Supply Voltage	V <sub>CC</sub>	-0.5	-	3.6	V

## RECOMMENDED OPERATING ENVIRONMENT

Parameter	Symbol	Min.	Typical	Max.	Unit
Operating Temperature	T <sub>o</sub>	-40	-	85	°C
Supply Voltage	V <sub>CC</sub>	3.15	3.3	3.45	V
Supply Current	I <sub>CC</sub>	-	-	300	mA
Data Rate		-	2.5	-	Gbps
Max Link Length on 9/125µm SMF	L <sub>max</sub>	-	-	2	km

## ELECTRICAL CHARACTERISTICS

Parameter	Symbol	Min.	Typical	Max.	Unit	Notes
<b>TRANSMITTER</b>						
Input Differential Impedance	Z <sub>in</sub>	90	100	110	Ω	
Data Input Swing Differential	V <sub>in</sub>	500	-	2400	mV	
Tx-Dis Disable	V <sub>d</sub>	2.0	-	V <sub>CC</sub>	V	
Tx-Dis Enable	V <sub>en</sub>	0	-	0.8	V	
TX-Fault (Fault)		2.0	-	V <sub>CC</sub> +0.3	V	
TX-Fault (Normal)		0	-	0.8	V	
<b>RECEIVER</b>						
Data Output Swing Differential	V <sub>out</sub>	370	-	2000	mV	
Rx-Los Fault	V <sub>lf</sub>	2.0	-	V <sub>CC</sub> +0.3	V	
Rx-Los Normal	V <sub>ln</sub>	0	-	0+0.8	V	

## OPTICAL PARAMETERS

Parameter	Symbol	Min.	Typical	Max.	Unit	Note
<b>TRANSMITTER</b>						
Centre Wavelength	$\lambda_c$	1270	1310	1370	nm	
Spectral Width (-20dB)	$\sigma$	-	-	1	nm	
Average Output Power	Pout	-5	-	0	dBm	
Extinction Ratio	ER	8	-	-	dB	
Optical Rise/Fall Time	tr/tf	-	-	1	ns	
<b>RECEIVER</b>						
Centre Wavelength	$\lambda_c$	1260	1310	1600	nm	
Receiver Sensitivity	PIN	-	-	-16	dBm	
Receiver Overload	PMAX	2	-	-	dBm	
LOS De-Assert	LOSD	-	-	-32	dBm	
LOS Assert	LOSA	-36	-	-	dBm	
LOS Hysteresis		0.5	-	-	dB	

## PIN DESCRIPTION

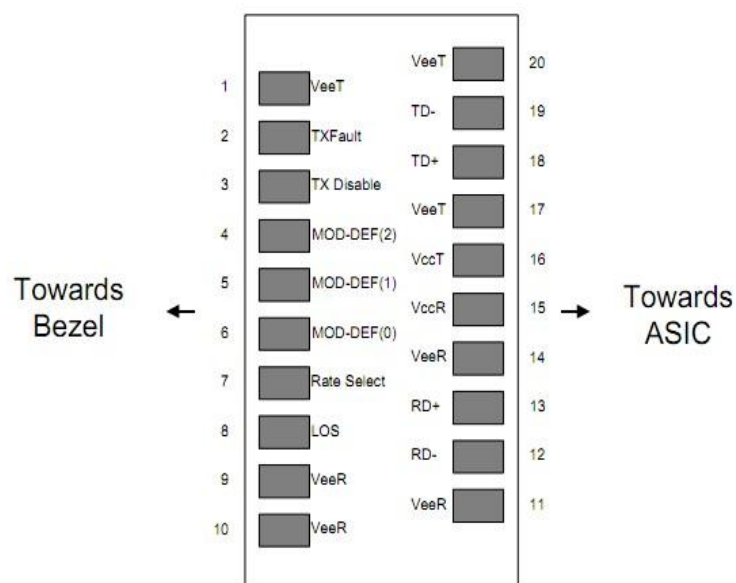

**Diagram of Host Board Connector Block Pin Numbers and Names**

## PIN FUNCTION DEFINITIONS

Pin	Name	Description	Notes
1	VEET	Transmitter Ground (Common with Receiver Ground)	1
2	TFAULT	Transmitter Fault.	
3	TDIS	Transmitter Disable. Laser output disabled on high or open.	2
4	MOD_DEF(2)	Module Definition 2. Data line for Serial ID.	3
5	MOD_DEF(1)	Module Definition 1. Clock line for Serial ID.	3
6	MOD_DEF(0)	Module Definition 0. Grounded within the module.	3
7	Rate Select	No connection required	
8	LOS	Loss of Signal indication. Logic 0 indicates normal operation.	4
9	VEER	Receiver Ground (Common with Transmitter Ground)	1
10	VEER	Receiver Ground (Common with Transmitter Ground)	1
11	VEER	Receiver Ground (Common with Transmitter Ground)	1
12	RD-	Receiver Inverted DATA out. AC Coupled.	
13	RD+	Receiver Non-inverted DATA out. AC Coupled.	
14	VEER	Receiver Ground (Common with Transmitter Ground)	1
15	VCCR	Receiver Power Supply	
16	VCCT	Transmitter Power Supply	
17	VEET	Transmitter Ground (Common with Receiver Ground)	1
18	TD+	Transmitter Non-Inverted DATA in. AC Coupled.	
19	TD-	Transmitter Inverted DATA in. AC Coupled.	
20	VEET	Transmitter Ground (Common with Receiver Ground)	1

### Notes:

1. Circuit ground is internally isolated from chassis ground.
2. Laser output disabled on TDIS >2.0V or open, enabled on TDIS <0.8V.
3. Should be pulled up with 4.7k - 10kOhms on host board to a voltage between 2.0V and 3.6V. MOD\_DEF(0) pulls line low to indicate module is plugged in.
4. LOS is open collector output. Should be pulled up with 4.7k -10kOhms on host board to a voltage between 2.0V and 3.6V. Logic 0 indicates normal operation; logic 1 indicates loss of signal.

# EEPROM

0~95
Serial ID Defined by SFP MSA (96 bytes)
96~127
Vendor Specific (32 bytes)
128~255
Reserved (128 bytes)

2 wire address 1010000X (A0h)

# DDM THRESHOLD

	Low Alarm	Low Warn	High Warn	High Alarm	Unit
Temperature	-45	-40	85	90	°C
Voltage	3	3.1	3.6	3.7	V
Tx Bias	3	4	125	130	mA
Tx Power	-8	-7	1	2	dBm
Rx Power	-23	-22	1	2	dBm

# RECOMMENDED CIRCUIT

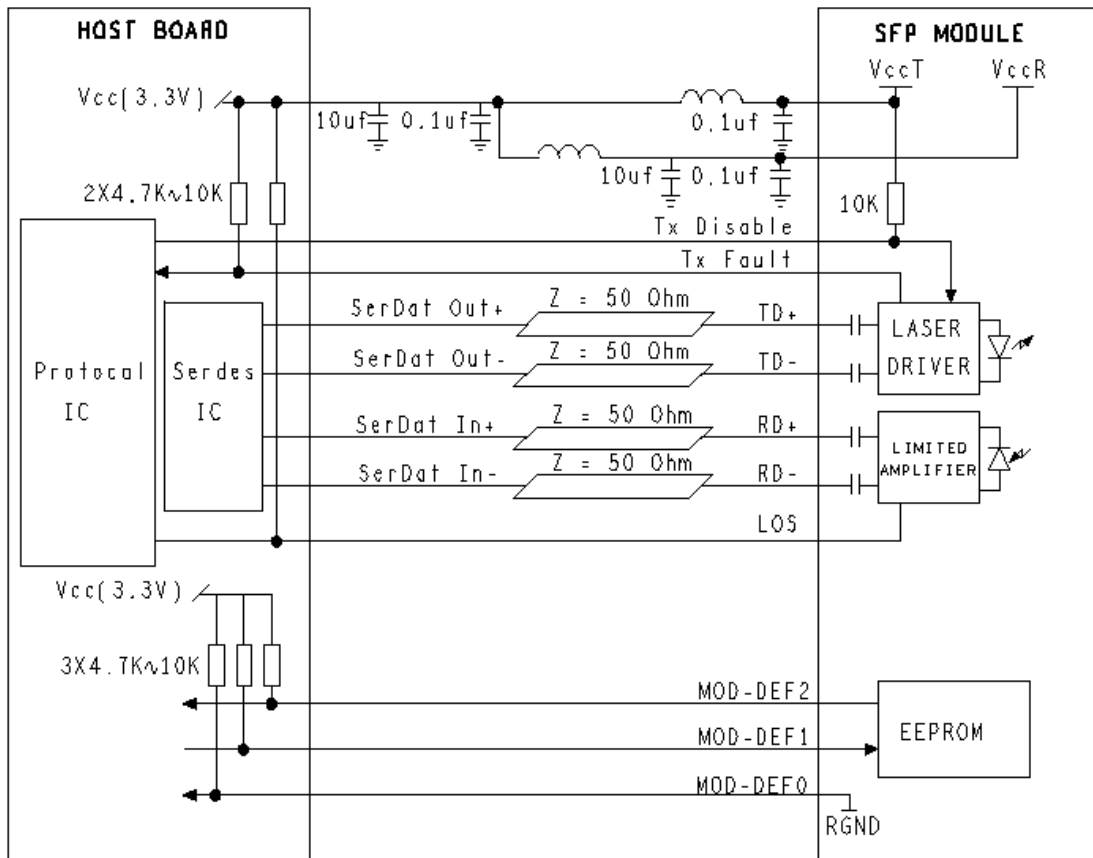

## MECHANICAL DIMENSIONS (UNIT: mm)

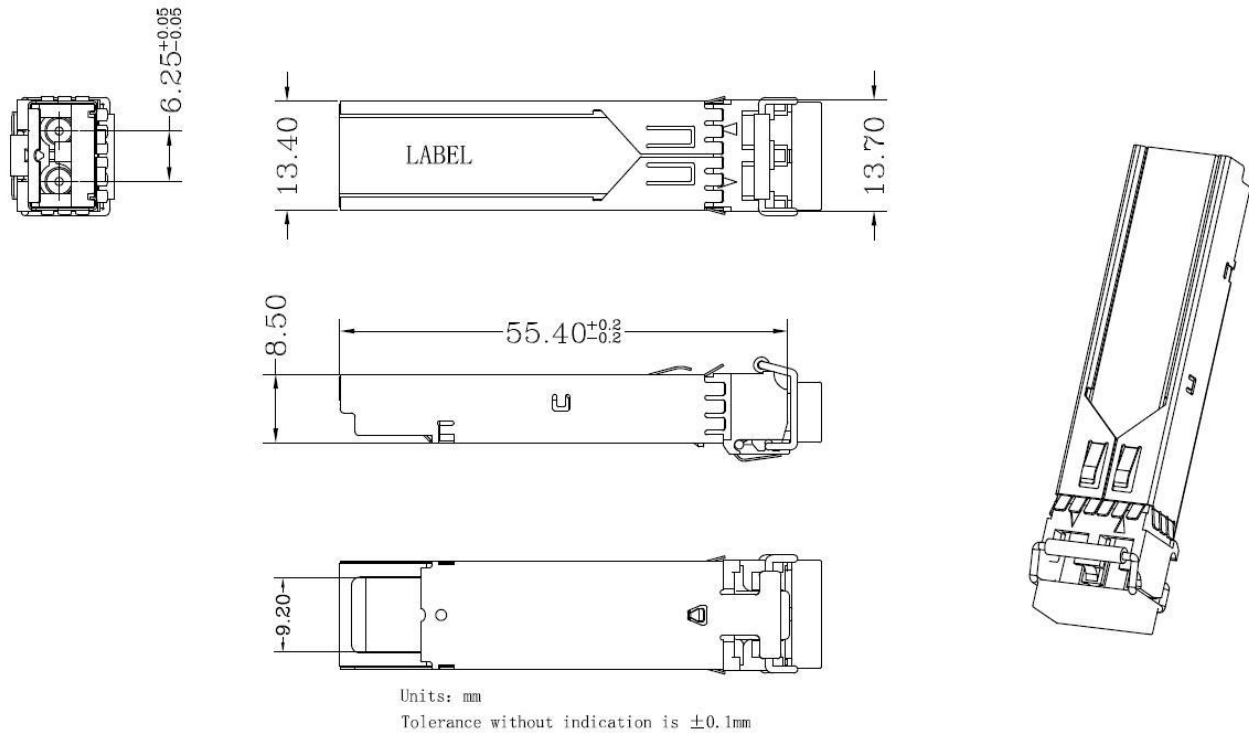

Mechanical Drawing

## REGULATORY COMPLIANCE

ATGBICS transceivers are Class 1 Laser Products compliant with FDA regulations and meet Class 1 eye safety requirements of EN 60825 and the electrical safety requirements of EN 60950.