



Main

Range of Product	Telemecanique Photoelectric sensors XU
Series name	Application
Electronic sensor type	Photo-electric sensor
Sensor name	XUY
Sensor design	Fork
Detection system	Thru beam
Emission	Infrared laser, modulated - class 1 IEC 825-1
Passage width	3.15 in (80 mm)
Passage depth	2.32 in (59 mm)
Material	Metal/plastic
Supply circuit type	DC
Wiring Technique	4-wire
Discrete output type	PNP and NPN
Discrete output function	1 NO or 1 NC programmable
Electrical connection	1 male connector M8, 4 pins
Product Specific Application	Detection of reference marks Detection of transparent object Detection on small conveyor Detection on vibrating rail
[Sn] nominal sensing distance	3.15 in (80 mm)

Complementary

Enclosure Material	Painted aluminium and polyamide/glass
Keypad Type	Green
Minimum object diameter for detection	0.00 in (0.05 mm)
Type of output signal	Discrete
Output Type	Solid state
Status LED	Adjustment mode and keypad locking 1 LED red) Output state 1 LED yellow)
[Us] rated supply voltage	12...24 V DC reverse polarity protection
Supply voltage limits	10...30 V DC
Switching capacity in mA	100 mA overload and short-circuit protection)
Switching frequency	10 kHz
Maximum voltage drop	<2 V closed state)
Current consumption	40 mA no-load
Load capacitance	330 nF
Time response	-20...20 µs
Setting-up	Sensitivity by numeric potentiometer
Net Weight	0.42 lb(US) (0.19 kg)

Environment

Product Certifications	CE cULus
Ambient Air Temperature for Operation	-4...140 °F (-20...60 °C)
Ambient Air Temperature for Storage	-22...176 °F (-30...80 °C)
Immunity to ambient light	10000 Lux natural light 5000 lux incandescent bulb
Vibration resistance	7 gn +/- 0.75 mm 10...55 Hz) IEC 60068-2-6

Shock resistance	30 gn 11 ms) IEC 60068-2-27
IP degree of protection	IP65 IEC 60529

Ordering and shipping details

Category	22481-SENSORS, PHOTOELECTRIC
Discount Schedule	DS2
GTIN	3389119006941
Returnability	No
Country of origin	FR

Packing Units

Unit Type of Package 1	PCE
Number of Units in Package 1	1
Package 1 Height	0.59 in (1.5 cm)
Package 1 Width	6.30 in (16.0 cm)
Package 1 Length	5.12 in (13.0 cm)
Package 1 Weight	3.46 oz (98.0 g)

Offer Sustainability

California proposition 65	WARNING: This product can expose you to chemicals including: Diisononyl phthalate (DINP), which is known to the State of California to cause cancer, and Di-isodecyl phthalate (DIDP), which is known to the State of California to cause birth defects or other reproductive harm. For more information go to www.P65Warnings.ca.gov
REACH Regulation	REACH Declaration
EU RoHS Directive	Pro-active compliance (Product out of EU RoHS legal scope) EU RoHS Declaration
Mercury free	Yes
RoHS exemption information	Yes

Contractual warranty

Warranty	18 months
----------	-----------

Dimensions

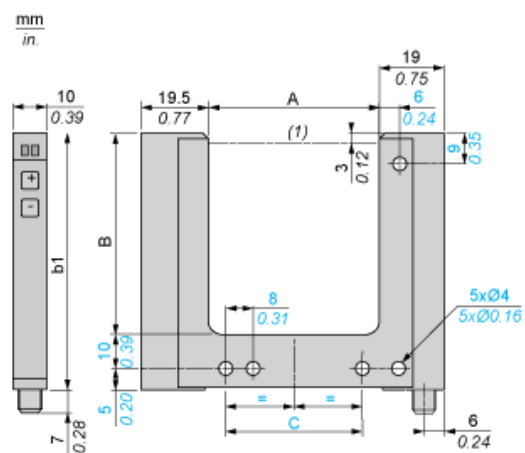

(1) Optical axis

Dimensions in mm

A	B	b1	C
80	59	74	70

Dimensions in in.

A	B	b1	C
3.15	2.32	2.91	2.76

Wiring Schemes

M8 Connector



- 1 : BN: Brown
- 2 : WH: White
- 3 : BU: Blue
- 4 : BK: Black

4-Wire, PNP/NPN Outputs



- BN : Brown
- WH : White
- BK : Black
- BU : Blue