

IS32LT3123 QUAD CHANNEL EXTERNAL NMOS FET HIGH CURRENT AUTOMOTIVE LED CONTROLLER WITH INTERNAL PWM DIMMING



DESCRIPTION

The IS32LT3123 is a quad channel linear controller capable of accurately regulating LED current with external NMOS FETs. It integrates PWM dimming for two LED brightness levels, such as “Stop” (full brightness) and “Tail” dim (PWM dimming) for RCL (Rear Combination Lamp) or DRL (Daytime Running Lamp) applications. A logic level at the PWMB pin is used to switch between the two brightness levels. A logic high provides the highest intensity output, while a logic low utilizes an internally generated PWM signal to reduce the intensity of the LEDs’ light output.

Multiple devices also can be connected in parallel in a master-slave structure for larger lighting applications.

For added system reliability, the IS32LT3123 integrates fault detection circuitry for LED open/short circuit, input over voltage and over temperature conditions. The FAULTB pin is dedicated to reporting fault conditions and the MODE pin can control the action of the device in case of a fault condition.

The IS32LT3123 also supports an external NTC resistor to monitor the LED string temperature. In case the temperature exceeds the setting threshold, the device will reduce the drive current to protect the LED string.

The IS32LT3123 package is an eTSSOP-24 with exposed pad for enhanced thermal dissipation.

QUICK START

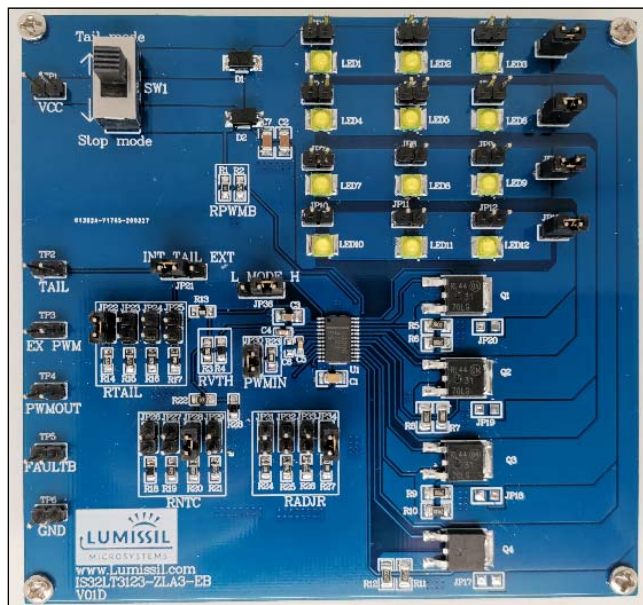

Figure 1 Photo of IS32LT3123 Evaluation Board

FEATURES

- Support for external low side NMOS FETs for high output current with independent current adjustment
- One resistor to simultaneously adjust all channels for LED binning
- 200mV reference feedback voltage for high efficiency
- $\pm 4\%$ current accuracy over $-40^{\circ}\text{C} \sim +125^{\circ}\text{C}$
- 5.0V to 40V supply voltage
- PWMB voltage input to select between full brightness and PWM dimming
- Flexible LED PWM dimming options
 - Internal PWM dimming set by resistors
 - ✓ Programmable duty cycle, 5%~95%
 - ✓ Programmable frequency, 100Hz~1kHz
 - External PWM signal input dimming
 - Analog voltage input for PWM dimming
- PWM slew rate control on each output to optimize EMI performance
- Robust fault protection
 - Fault reporting
 - ✓ LED string open/short
 - ✓ Thermal shutdown
 - LED string over temperature thermal rolloff
 - Input over voltage current derating
 - Controller junction over temperature thermal rolloff
- Multiple parallel IC operation for higher number of strings with fault condition and PWM dimming synchronization
- RoHS & Halogen-Free Compliance
- TSCA Compliance
- AEC-Q100 Qualified with Temperature Grade 1: -40°C to 125°C

RECOMMENDED EQUIPMENT

- 12V, 1A DC power supply

ABSOLUTE MAXIMUM RATINGS

- $\leq 24\text{V}$ power supply

Caution: Do not exceed the conditions listed above, otherwise the MOSFETs may be damaged due to overheat. IS32LT3123 is capable to support up to 40V input. However the MOSFETs without additional heatsink can overheat at high input voltages.

PROCEDURE

The IS32LT3123 demo board is fully assembled and tested. Follow the steps listed below to verify board operation.

Caution: Do not turn on the power supply until all connections are completed.

IS32LT3123 QUAD CHANNEL EXTERNAL NMOS FET HIGH CURRENT AUTOMOTIVE LED CONTROLLER WITH INTERNAL PWM DIMMING



- 1) Connect the negative terminal of power supply to GND header (TP6).
- 2) Connect the positive terminal of power supply to connector VCC header (TP1).
- 3) There are 4 onboard LED strings, one for each channel. Each string can be adjusted from 1 to 3 LEDs by jumpers, JP10~JP12 for channel 1, JP7~JP9 for channel 2, JP4~JP6 for channel 3 and JP1~JP3 for channel 4. Close the jumper to disable and open to enable the corresponding LED. If all jumpers of any channel are closed, the corresponding LED string will be shorted which can be used for LED string short fault simulation.
- 4) The maximum current is set at 200mA per channel by FB resistors (R5~12). JP31~JP34 are used to select resistor values which fine tune the peak currents.
- 5) For Tail mode (PWM dimming mode), the PWM is capable to modulate the average output current based on the above maximum current. The PWM dimming source can be either an internal or an external PWM:
 - a) To support the internal PWM dimming, connect the jumper JP21 to "INT" side and close one jumper of JP22~JP25 to select a different internal PWM duty cycle. JP21 and JP22~JP25 form a voltage divider to generate a PWM voltage from the VDD pin (5.25V typ). To adjust the internal PWM duty cycle with an external source, connect jumper JP21 to "EXT" side, open all jumpers (JP22~JP25), and apply an external analog voltage <3.7V to TP2.
 - b) To support external PWM dimming, connect jumper JP21 to "INT" side and open all jumpers JP22~JP25, and JP30. Apply an external PWM signal to TP3 to modulate the average output current. The recommended frequency of the external PWM signal is 100Hz~1kHz and the duty cycle range can be 0~100%.
- 6) The TP4 is the PWM signal output pin which can be used to drive other slave devices for synchronized PWM dimming. During internal PWM mode, TP4's output is the internal PWM generator. When in external PWM mode, TP4 outputs a signal synchronized with the signal on TP3.
- 7) The RNTC resistors are used to simulate the external NTC thermal rolloff function. Close one jumper of JP26~JP29 to reduce the output current by different levels.
- 8) The device supports various fault protections, including LED string open/short, VIN over voltage, device junction thermal rolloff, thermal shutdown and so on. Only LED string open/short or thermal shutdown will report as a fault, the FAULTB pin will pull low to report these fault conditions. Monitor FAULTB pin status on TP5.
- 9) The device supports two fault action modes, "one fail all fail" or "one fail all on", which can be set by the jumper JP36. Connect JP36 to "H" side for "one fail all fail" mode and "L" side for "one fail all on" mode.
- 10) The jumpers JP13~JP16 are used for LED string open fault simulation, JP16 for channel 1, JP15 for channel 2, JP14 for channel 3 and JP13 for channel 4. In normal operation, all should be closed. If need to open any LED string, open the corresponding jumper.
- 11) Turn on the power supply and LEDs will light up.
- 12) Use slider switch SW1 to select between "STOP" and "TAIL" modes.

Note: refer to the "TABLE 2 JUMPER/SWITCH SETTING" for more information on the jumpers' setting.

Caution: Since the output power is quite high while the DEMO board dimension is compact, the temperature of the components will be quite high. DO NOT touch the components during operation. In practice, some type of heatsinking should be considered, such as mount a larger heatsink and fill with thermal conductive glue for cooling to ensure thermal reliability.

ORDERING INFORMATION

Part No.	Temperature Range	Package
IS32LT3123-ZLA3-EB	-40°C to +125°C (Automotive)	eTSSOP-24, Lead-free

Table 1 Ordering Information

For pricing, delivery, and ordering information, please contact Lumissil's analog marketing team at analog@lumissil.com or (408) 969-6600.

Table 2 Jumper/Switch Setting

Jumper/Switch	Functions	Setting
JP1-JP12	Select the number of LEDs on each string	Close: Disable the corresponding LED Open: Enable the corresponding LED
JP13-JP16	Open LED string	Close: Enable the corresponding LED string Open: Open the corresponding LED string
JP21	TAIL pin setting	Connect to "INT" side: Connect the TAIL pin to the bias circuits on board Connect to "EXT" side: Leave the TAIL pin floating for the external analog voltage input
JP22-JP25	Set the internal PWM duty cycle <i>(Select single jumper to close and open the other three)</i>	Close JP22: 90% PWM duty cycle (typ.) Close JP23: 50% PWM duty cycle (typ.) Close JP24: 20% PWM duty cycle (typ.) Close JP25: 7% PWM duty cycle (typ.)
JP26-JP29	Simulate external NTC thermal rolloff function <i>(Select single jumper to close and open the other three)</i>	Close JP26: No rolloff Close JP27: V _{REF} decreased by about 10mV Close JP28: V _{REF} decreased by about 100mV Close JP29: V _{REF} decreased by about 133mV
JP31-JP34	Set the internal reference voltage <i>(Select single jumper to close and open the other three)</i>	Close JP31: V _{REF} =V _{REFMAX} =200mV (typ.) Close JP32: V _{REF} =180mV (typ.) Close JP33: V _{REF} =133mV (typ.) Close JP34: V _{REF} =100mV (typ.)
JP30	PWMIN pin setting	Close: Connect the PWMIN pin via a resistor to GND Open: Leave the PWMIN pin floating for the external PWM signal input
JP36	Select fault action mode	Connect to "L" side: "One fail all fail" mode Connect to "H" side: "One fail all on" mode
SW1	Select operation mode	Up: "TAIL" mode (PWM dimming) Down: "STOP" mode (Full brightness)

EVALUATION BOARD OPERATION

OUTPUT CURRENT SETTING

The IS32LT3123 provides 4 channels of low-side current drive via 4 external NMOS FETs. The negative feedback loops drive the GATES of NMOS FETs to maintain the current feedback voltage of FB pins equal to the internal reference voltage, V_{REF}. All channels share the same reference voltage source. So V_{REF} decides the output current. The regulated maximum LED current of each NMOS FET is individually set by its corresponding feedback resistor (R_{FB}). V_{REF} can be controlled by ADJR resistor (R_{ADJR}), NTC thermal rolloff protection, input over voltage protection and thermal rolloff protection actions. If R_{ADJR} ≥ 3kΩ and no protection actions, V_{REF} is maximum value, V_{REFMAX} (Typ. 0.2V). The feedback resistor value can be computed using the following:

$$R_{FB} = \frac{V_{REFMAX}}{I_{OUT_FULL}} \quad (1)$$

Where I_{OUT_FULL} is the output current at full brightness mode (without PWM dimming) in Amps and R_{FB} is in Ω.

CURRENT ADJUSTMENT BY ADJR

The ADJR pin is a dedicated pin for fine tuning the output current. Connecting a proper range value resistor, R_{ADJR}, from this pin to GND will adjust the output current, which can be used for LED binning or output power ranking purposes.

If R_{ADJR} value is greater than or equal to 3kΩ, the V_{REF} is clamped at maximum value, V_{REFMAX} (typ. 0.2V). The output current will be the maximum setting value, I_{OUT_FULL} in Equation (1).

If R_{ADJR} value is between 1kΩ and 3kΩ, the V_{REF} value is calculated by:

$$V_{REF} = \left(\frac{R_{ADJR} \times 1mA}{3V} \right) \times 0.2V \quad (3)$$

So the output current can be adjusted by this resistor:

$$I_{OUT_ADJR} = \frac{\left(\frac{R_{ADJR} \times 1mA}{3V} \right) \times 0.2V}{R_{FB}} \quad (4)$$

Where R_{ADJR} is in kΩ and R_{FB} is in Ω.

If the R_{ADJR} value is smaller than or equal to 1k Ω , V_{REF} is clamped at 0.067V (Typ.). Then the output current will be:

$$I_{OUT_ADJR} = \frac{0.067V}{R_{FB}} \quad (5)$$

LED THERMAL ROLLOFF PROTECTION BY NTC

IS32LT3123 is capable to implement LED over temperature current roll off protection in conjunction with an external NTC thermistor placed close to the LEDs. As Figure 31 in the datasheet, NTC pin voltage, V_{NTC} , is monitored and feedback to the Reference Voltage Generator circuit to adjust the internal reference voltage, V_{REF} . V_{NTC} will not affect V_{REF} until dropping below the NTC pin's voltage threshold, V_{NTC_TH} (typ. 2.2V). If $V_{NTC} \geq V_{NTC_TH}$, V_{REF} is clamped at the value set by R_{ADJR} . Once $V_{NTC} < V_{NTC_TH}$, the internal reference voltage is decided by V_{NTC} :

$$V_{REF_NTC} = V_{REF} - \frac{2.2V - V_{NTC}}{10} \quad (6)$$

Where, V_{REF} is set by R_{ADJR} value, as Equation (3) ~ (5). So the output current with NTC pin's adjustment will be:

$$I_{OUT_NTC} = \frac{V_{REF_NTC}}{R_{FB}} \quad (7)$$

INTERNAL PWM DIMMING MODE

When the TAIL pin is connected to a voltage below 3.7V (typ.), the IS32LT3123 will be in internal PWM dimming mode. As in Figure 1 of the datasheet. The integrated PWM generator is enabled and the voltage on TAIL pin determines the PWM duty cycle. The PWM duty cycle can be calculated as follows:

$$D_{PWM} = 160 \times \frac{V_{TAIL}}{V_{DD}} - 7.9 \quad (14)$$

Where, D_{PWM} is PWM duty cycle in %. V_{DD} and V_{TAIL} are in Volts.

To get better accuracy, it is recommended to derive V_{TAIL} using a precise resistor divider from V_{DD} (as R_{TAIL1} and R_{TAIL2} in Figure 1 of the datasheet, 1% accuracy resistors are recommended) and the recommended duty cycle setting range is 5%~95%. The lower duty cycle results in lower output current accuracy. A 1nF X7R type ceramic capacitor, C_{TAIL} , should be added and placed close to TAIL pin for noise decoupling. The output current is modulated by the PWM duty cycle:

$$I_{OUT_PWM} = I_{OUT_FULL} \times D_{PWM} \quad (15)$$

If $R_{ADJR} < 3K\Omega$, the output current will be:

$$I_{OUT_PWM} = I_{OUT_ADJR} \times D_{PWM} \quad (16)$$

When the duty cycle is set by the TAIL pin, the PWM frequency is programmed by a single resistor, R_{FPWM} , connected from PWMIN pin to GND. The PWM frequency can be set in a range of 100Hz~1kHz. Since the output current has slew rate control for EMI consideration, the lower PWM frequency will get better output accuracy. The resistor value can be calculated as follows:

$$R_{FPWM} = \frac{5380}{f_{PWM} - 20.7} \quad (17)$$

Where, f_{PWM} is desired PWM frequency in Hz and R_{FPWM} is in k Ω .

An external voltage on the TAIL pin instead of the resistor divider can be used for analog input PWM dimming.

EXTERNAL PWM DIMMING MODE

When the TAIL pin is tied to V_{DD} directly, the IS32LT3123 will be in external PWM dimming mode. As in Figure 2 of the datasheet. The integrated PWM generator is disabled. An external PWM signal on PWMIN pin can modulate the output current based on the duty cycle. The recommended frequency range of the external PWM signal is 100Hz~1kHz and the duty cycle can be from 0 to 100%. Since the output current has slew rate control for EMI consideration, a lower frequency PWM will get better dimming contrast ratio. The calculation of output current is identical as Equation (15) and (16). Note that the PWMIN pin is high impedance input in external PWM dimming mode.

FAULT PROTECTION AND REPORTING

For robust system reliability, the IS32LT3123 integrates detection circuitry to protect various fault conditions and report the fault conditions on the FAULTB pin which can be monitored by an external host. The fault protections include LED string open/short, VIN over voltage, controller junction thermal rolloff, LED thermal rolloff and thermal shutdown. Refer to Table 3. The FAULTB pin is open drain structure with both input and output capability. The FAULTB pin is not allowed to float. An external resistor, R_{FAULTB} , connected to VDD pin must be added to pull up FAULTB pin above 2V for normal operation. The recommended resistor value is 47k Ω . The FAULTB pin will go low when the device detects a fault condition.

As an input pin (MODE pin high), externally pulling FAULTB pin low will disable the output. For lighting systems with multiple IS32LT3123 controllers which require the complete lighting system be shut down when a fault is detected, the FAULTB pin can be used in a parallel connection as shown in Figure 4 of the datasheet. A fault output by one device will pull low the FAULTB pins of the other parallel connected devices and simultaneously turn them off. This satisfies the "one fail all fail" operating requirement.

IS32LT3123 QUAD CHANNEL EXTERNAL NMOS FET HIGH CURRENT AUTOMOTIVE LED CONTROLLER WITH INTERNAL PWM DIMMING



Table 3 Fault Condition

Protection Type	Detect Condition	FAULTB	MODE=V _{DD} (one fail all fail)				MODE=GND (one fail all on)			
			PWMOUT	Faulty String	Other Strings	Recover	PWMOUT	Faulty String	Other Strings	Recover
Short LED	$(V_{IN}-V_{DETX}) < V_{SCV}$	Pulled low	Pulled low	Keep on with 100% duty cycle irrespective of any PWM mode.	Turn off	Fault condition removed	Normal	The LEDs will be off due to shorted, however the current in the NMOS FET will be normal.	Normal	Fault condition removed
		This fault is detected after all GATE _x high and completion of reference ramp. When detected, the fault remains active independent of GATE status.								
Open LED	$V_{IN} > V_{INOC_TH}$ and $V_{DETX} < V_{OCV}$	Pulled low	Pulled low	Keep on with 100% duty cycle irrespective of any PWM mode.	Turn off	Fault condition removed	Normal	The LEDs will be off due to open, however the corresponding GATE pin will be high.	Normal	Fault condition removed
Controller Thermal Rolloff	T_J exceeds 145°C	Normal	Normal	All string current derates based on junction temperature.		T_J drops below 145°C	Normal	All string current derates based on junction temperature.		T_J drops below 145°C
V _{IN} Over Voltage	$V_{IN} > V_{INOV_TH}$	Normal	Normal	All string current derates based on supply voltage.		$V_{IN} \leq V_{INOV_TH}$	Normal	All string current derates based on supply voltage.		$V_{IN} \leq V_{INOV_TH}$
Thermal Shutdown	T_J exceeds 170°C	Pulled low	Pulled low	All string turn off		T_J drops below 140°C	Normal	All string turn off		T_J drops below 140°C
LED String Thermal Rolloff	$V_{NTC} < V_{NTC_TH}$	Normal	Normal	All string current derates based on NTC pin voltage.		$V_{NTC} \geq V_{NTC_TH}$	Normal	All string current derates based on NTC pin voltage.		$V_{NTC} \geq V_{NTC_TH}$

IS32LT3123 QUAD CHANNEL EXTERNAL NMOS FET HIGH CURRENT AUTOMOTIVE LED CONTROLLER WITH INTERNAL PWM DIMMING

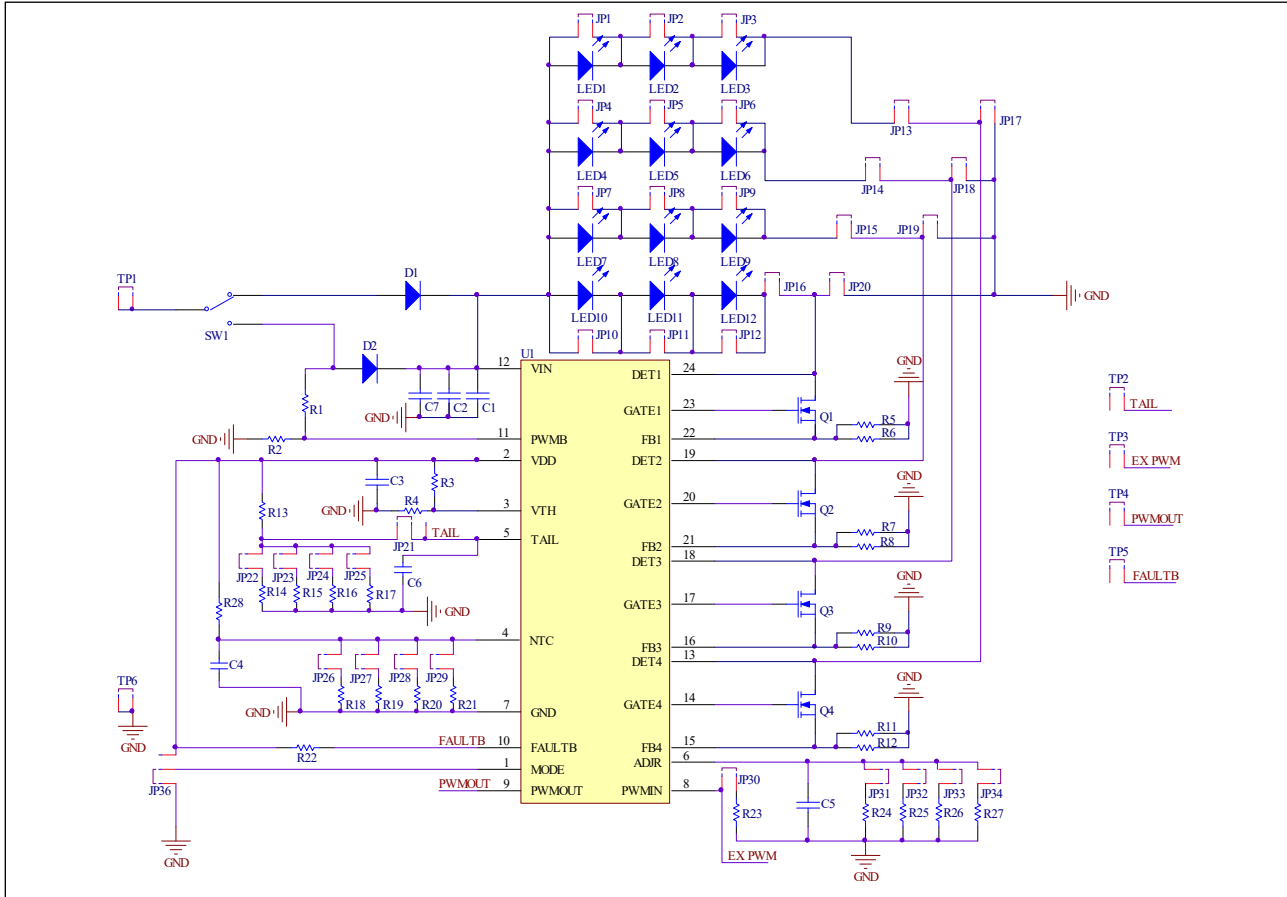

Figure 2 IS32LT3123 Application Schematic

IS32LT3123 QUAD CHANNEL EXTERNAL NMOS FET HIGH CURRENT AUTOMOTIVE LED CONTROLLER WITH INTERNAL PWM DIMMING



BILL OF MATERIALS

Name	Symbol	Description	Qty	Supplier	Part No.
NC	C6,JP17~JP20				
LED Driver	U1	Constant current LED driver	1	Lumissil	IS32LT3123
Capacitor	C1	CAP,100nF,50V,±10%,SMD	1	Yageo	AC0603KR8BB104
Capacitor	C2,C7	CAP,1µF,50V,±10%,SMD	2	Yageo	C0805KKX7R8BB105
Capacitor	C3	CAP,1µF,25V,±10%,SMD	1	Yageo	AC1206KKX7R9BB105
Capacitor	C4	CAP,1nF,50V,±10%,SMD	1	Yageo	AC0603KPX79BB102
Capacitor	C5	CAP,10nF,50V,±10%,SMD	1	Yageo	AC0603KPX79BB103
Resistor	R1,R4, R18,R28	RES,10kR,0805,±1%,SMD	4	Yageo	AC0805JR-0710KL
Resistor	R2,R22	RES,47kR,0805,±1%,SMD	2	Yageo	AC0805JR-0747KL
Resistor	R3	RES,20kR,0805,±1%,SMD	1	Yageo	AC0805JR-0720KL
Resistor	R5, R6, R7, R8, R9, R10, R11, R12	RES,2R,1206,±1%,SMD	8	Yageo	AC1206FR-072RL
Resistor	R13	RES,39kR,0805,±1%,SMD	1	Yageo	RC0805JR-0739KL
Resistor	R14	RES,62kR,0805,±1%,SMD	1	Yageo	RC0805JR-0762KL
Resistor	R15	RES,22kR,0805,±1%,SMD	1	Yageo	RC0805JR-0722KL
Resistor	R16	RES,8.2kR,0805,±1%,SMD	1	Yageo	AC0805FR-078K2L
Resistor	R17	RES,3.9kR,0805,±1%,SMD	1	Yageo	AC0805FR-073K9L
Resistor	R19	RES,6.8kR,0805,±1%,SMD	1	Yageo	AC0805FR-076K8L
Resistor	R20	RES,3kR,0805,±1%,SMD	1	Yageo	AC0805FR-073KL
Resistor	R21, R26	RES,2kR,0805,±1%,SMD	2	Yageo	AC0805FR-072KL
Resistor	R23	RES,33kR,0805,±1%,SMD	1	Yageo	RC0805JR-0733KL
Resistor	R24	RES,3.6kR,0805,±1%,SMD	1	Yageo	AC0805FR-073K6L
Resistor	R25	RES,2.7kR,0805,±1%,SMD	1	Yageo	AC0805FR-072K7L
Resistor	R27	RES,1.5kR,0805,±1%,SMD	1	Yageo	AC0805FR-071K5L
NFET	Q1~Q4	60V/9A,N-Channel MOS	4	ONsemi	NTD3055L170
Diode	D1, D2	3A,60V	2	ONsemi	SS36
LED	LED1~LED12	White LED,1W,V _F =3.2V	12		
Switch	SW1	SPDT,13mm×6.5mm,1A	1		
Header	JP1~JP16, JP22~JP34	2 pin headers	29		
Header	JP21,JP36	3 pin headers	2		

Bill of Materials refers to Figure 2 above.

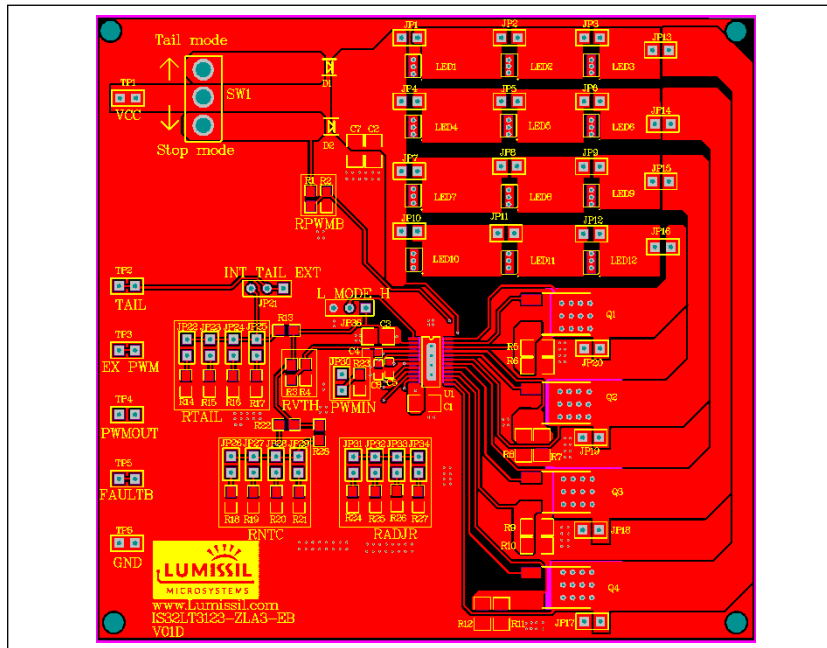

Figure 3 Board PCB Layout - Top Layer

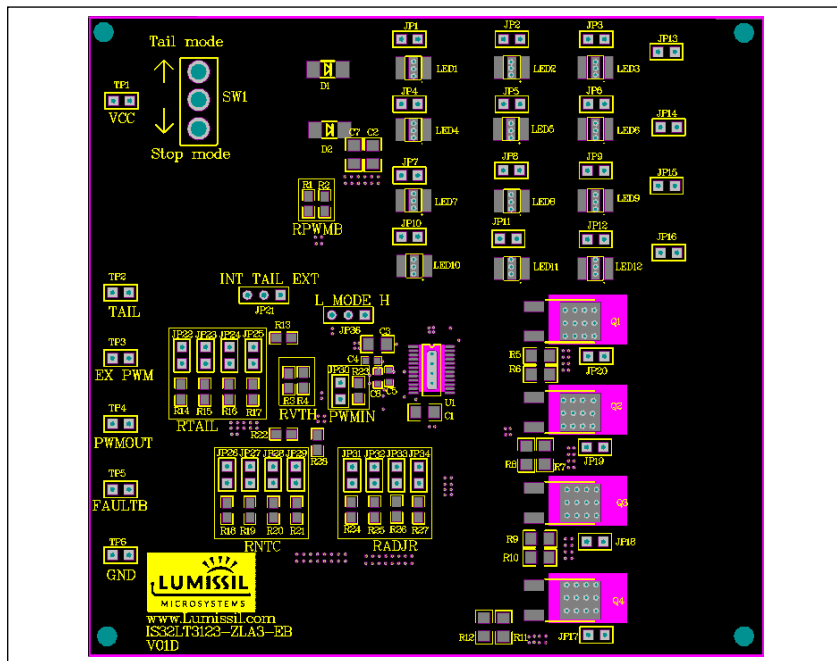

Figure 4 Board Component Placement Guide - Top Layer

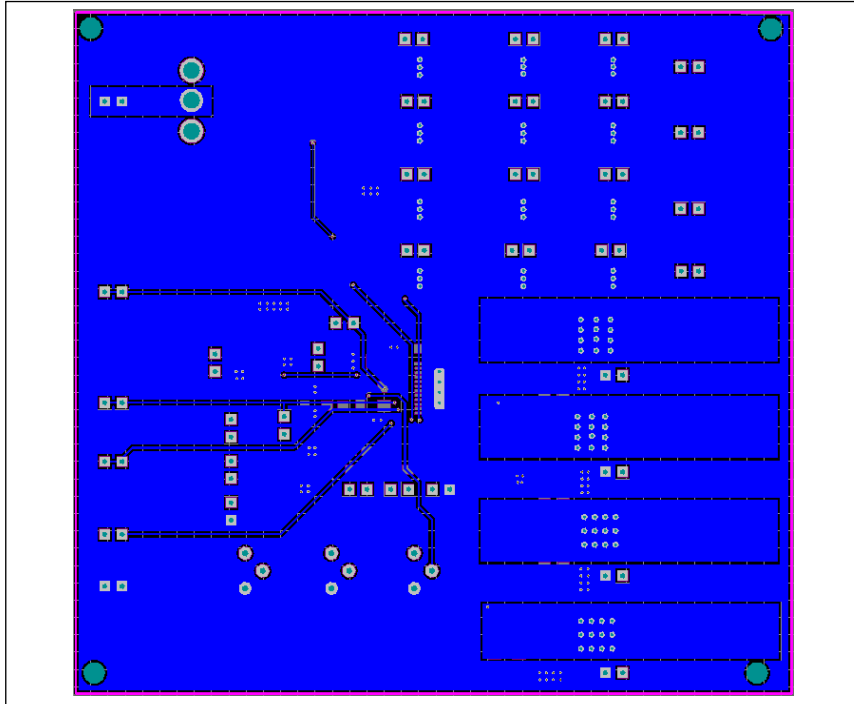

Figure 5 Board PCB Layout - Bottom Layer

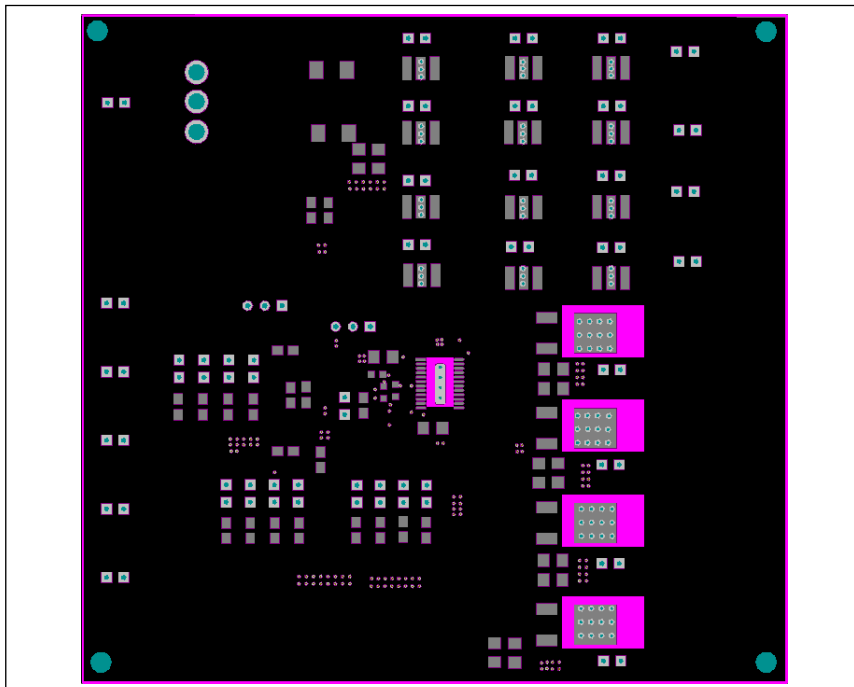

Figure 6 Board Component Placement Guide - Bottom Layer

Copyright © 2024 Lumissil Microsystems. All rights reserved. Lumissil Microsystems reserves the right to make changes to this specification and its products at any time without notice. Lumissil Microsystems assumes no liability arising out of the application or use of any information, products or services described herein. Customers are advised to obtain the latest version of this device specification before relying on any published information and before placing orders for products.

Lumissil Microsystems does not recommend the use of any of its products in life support applications where the failure or malfunction of the product can reasonably be expected to cause failure of the life support system or to significantly affect its safety or effectiveness. Products are not authorized for use in such applications unless Lumissil Microsystems receives written assurance to its satisfaction, that:

- a.) the risk of injury or damage has been minimized;
- b.) the user assume all such risks; and
- c.) potential liability of Lumissil Microsystems is adequately protected under the circumstances

IS32LT3123 QUAD CHANNEL EXTERNAL NMOS FET HIGH CURRENT AUTOMOTIVE LED CONTROLLER WITH INTERNAL PWM DIMMING



REVISION HISTORY

Revision	Detail Information	Date
A	Initial release	2020.04.14
B	Update to new Lumissil logo, AECQ and add RoHS	2024.12.12