



direct-on-line starter, 3RM1, 500 V, 0.09 - 0.75 kW, 0.4 - 2 A, 110-230 V AC, spring-loaded terminal (push-in)

product brand name	SIRIUS
product category	Motor starter
product designation	Direct-on-line starter
design of the product	with electronic overload protection
product type designation	3RM1
General technical data	
equipment version according to IEC 60947-4-2	3
product function	Direct-on-line starter
<ul style="list-style-type: none"> intrinsic device protection 	Yes
<ul style="list-style-type: none"> for power supply reverse polarity protection 	No
suitability for operation device connector 3ZY12	No
power loss [W] for rated value of the current	
<ul style="list-style-type: none"> at AC in hot operating state per pole 	0.1 W
<ul style="list-style-type: none"> without load current share typical 	5.06 W
insulation voltage rated value	500 V
overvoltage category	III
surge voltage resistance rated value	6 kV
maximum permissible voltage for protective separation	
<ul style="list-style-type: none"> between main and auxiliary circuit 	500 V
<ul style="list-style-type: none"> between control and auxiliary circuit 	250 V
shock resistance	6 g / 11 ms
vibration resistance	1 ... 6 Hz, 15 mm; 20 m/s ² , 500 Hz
operating frequency maximum	1 1/s
reference code according to IEC 81346-2	Q
Substance Prohibitance (Date)	03/01/2017
SVHC substance name	Lead CAS-No. 7439-92-1 Lead monoxide (lead oxide) CAS-No. 1317-36-8 2-methyl-1-(4-methylthiophenyl)-2-morpholinopropan-1-one CAS-No. 71868-10-5 Melamine CAS-No. 108-78-1 6,6'-di-tert-butyl-2,2'-methylenedi-p-cresol CAS-No. 119-47-1
Net Weight	0.285 kg
product function	
<ul style="list-style-type: none"> direct start 	Yes
<ul style="list-style-type: none"> reverse starting 	No
product function short circuit protection	No
Electromagnetic compatibility	
EMC emitted interference according to IEC 60947-1	class A
EMC immunity according to IEC 60947-1	Class A
conducted interference	

<ul style="list-style-type: none"> • due to burst according to IEC 61000-4-4 • due to conductor-earth surge according to IEC 61000-4-5 • due to conductor-conductor surge according to IEC 61000-4-5 • due to high-frequency radiation according to IEC 61000-4-6 	3 kV / 5 kHz 2 kV 1 kV 10 V
field-based interference according to IEC 61000-4-3	10 V/m
electrostatic discharge according to IEC 61000-4-2	4 kV contact discharge / 8 kV air discharge
conducted HF interference emissions according to CISPR11	Class B for domestic, business and commercial environments; Class A for industrial environments at 110 V DC
field-bound HF interference emission according to CISPR11	Class B for domestic, business and commercial environments; Class A for industrial environments at 110 V DC
Safety related data	
product function suitable for safety function	No
suitability for use	
<ul style="list-style-type: none"> • safety-related switching on • safety-related switching OFF 	No No
test wear-related service life necessary	No
ISO 13849	
overdimensioning according to ISO 13849-2 necessary	No
Electrical Safety	
protection class IP on the front according to IEC 60529	IP20
touch protection on the front according to IEC 60529	finger-safe
Main circuit	
number of poles for main current circuit	3
design of the switching contact	Hybrid
design of the switching contact as NO contact for signaling function	OUT, electronic, 24 V DC, 15 mA
adjustable current response value current of the current-dependent overload release	0.4 ... 2 A
minimum load [%]	20 %; from set rated current
type of the motor protection	solid-state
operating voltage rated value	48 ... 500 V
relative symmetrical tolerance of the operating voltage	10 %
operating frequency 1 rated value	50 Hz
operating frequency 2 rated value	60 Hz
relative symmetrical tolerance of the operating frequency	10 %
operational current	
<ul style="list-style-type: none"> • at AC at 400 V rated value • at AC-3 at 400 V rated value • at AC-53a at 400 V at ambient temperature 40 °C rated value 	2 A 2 A 2 A
ampacity when starting maximum	16 A
operating power for 3-phase motors at 400 V at 50 Hz	0.09 ... 0.75 kW
Inputs/ Outputs	
input voltage at digital input at DC rated value	110 V
input voltage at digital input at AC rated value	110 V
input current at digital input	
<ul style="list-style-type: none"> • for signal <1> at DC • with signal <0> at DC 	1.5 mA 0.25 mA
input current at digital input with signal <0> at AC	
<ul style="list-style-type: none"> • at 110 V • at 230 V 	0.2 mA 0.4 mA
input current at digital input for signal <1> at AC	
<ul style="list-style-type: none"> • at 110 V • at 230 V 	1.1 mA 2.3 mA
number of CO contacts for auxiliary contacts	1
operational current of auxiliary contacts at AC-15 at 230 V maximum	3 A
operational current of auxiliary contacts at DC-13 at 24 V maximum	1 A

Control circuit/ Control	
type of voltage of the control supply voltage	AC/DC
control supply voltage at AC	
• at 50 Hz rated value	110 ... 230 V
• at 60 Hz rated value	110 ... 230 V
relative negative tolerance of the control supply voltage at AC at 60 Hz	15 %
relative positive tolerance of the control supply voltage at AC at 60 Hz	10 %
control supply voltage 1 at AC	
• at 50 Hz	110 ... 230 V
• at 60 Hz	110 ... 230 V
control supply voltage frequency	
• 1 rated value	50 Hz
• 2 rated value	60 Hz
relative negative tolerance of the control supply voltage at DC	15 %
relative positive tolerance of the control supply voltage at DC	10 %
control supply voltage 1 at DC rated value	110 V
operating range factor control supply voltage rated value at DC	
• initial value	0.85
• full-scale value	1.1
operating range factor control supply voltage rated value at AC at 50 Hz	
• initial value	0.85
• full-scale value	1.1
operating range factor control supply voltage rated value at AC at 60 Hz	
• initial value	0.85
• full-scale value	1.1
control current at AC	
• at 110 V in standby mode of operation	16 mA
• at 230 V in standby mode of operation	9 mA
• at 110 V when switching on	55 mA
• at 230 V when switching on	33 mA
• at 110 V during operation	36 mA
• at 230 V during operation	22 mA
control current at DC	
• in standby mode of operation	6 mA
• during operation	30 mA
inrush current peak	
• at AC at 110 V	1 200 mA
• at AC at 230 V	2 900 mA
• at AC at 110 V at switching on of motor	1 200 mA
• at AC at 230 V at switching on of motor	2 900 mA
duration of inrush current peak	
• at AC at 110 V	1 ms
• at AC at 230 V	1 ms
• at AC at 110 V at switching on of motor	1 ms
• at AC at 230 V at switching on of motor	1 ms
power loss [W] in auxiliary and control circuit	
• in switching state OFF	
— with bypass circuit	2.1 W
• in switching state ON	
— with bypass circuit	5.06 W
Response times	
ON-delay time	60 ... 90 ms
OFF-delay time	60 ... 90 ms
Power Electronics	

operational current	
<ul style="list-style-type: none"> • at 40 °C rated value • at 50 °C rated value • at 55 °C rated value • at 60 °C rated value 	<p>2 A</p> <p>2 A</p> <p>2 A</p> <p>2 A</p>
Installation/ mounting/ dimensions	
mounting position	vertical, horizontal, standing (observe derating)
fastening method	screw and snap-on mounting onto 35 mm DIN rail
height	100 mm
width	22.5 mm
depth	141.5 mm
required spacing	
<ul style="list-style-type: none"> • with side-by-side mounting <ul style="list-style-type: none"> — forwards — backwards — upwards — downwards — at the side • for grounded parts <ul style="list-style-type: none"> — forwards — backwards — upwards — at the side — downwards 	<p>0 mm</p> <p>0 mm</p> <p>50 mm</p> <p>50 mm</p> <p>0 mm</p> <p>0 mm</p> <p>0 mm</p> <p>50 mm</p> <p>3.5 mm</p> <p>50 mm</p>
Ambient conditions	
installation altitude at height above sea level maximum	4 000 m
ambient temperature	
<ul style="list-style-type: none"> • during operation • during storage • during transport 	<p>-25 ... +60 °C</p> <p>-40 ... +70 °C</p> <p>-40 ... +70 °C</p>
environmental category during operation according to IEC 60721	3K6 (no ice formation, only occasional condensation), 3C3 (no salt mist), 3S2 (sand must not get into the devices), 3M6
relative humidity during operation	10 ... 95 %
air pressure according to SN 31205	900 ... 1 060 hPa
Communication/ Protocol	
protocol is supported	
<ul style="list-style-type: none"> • PROFINET IO protocol • PROFI-safe protocol 	<p>No</p> <p>No</p>
product function bus communication	No
protocol is supported AS-Interface protocol	No
Connections/ Terminals	
type of electrical connection	spring-loaded terminals (push-in) for main circuit, spring-loaded terminals (push-in) for control circuit
<ul style="list-style-type: none"> • for main current circuit • for auxiliary and control circuit 	<p>spring-loaded terminals (push-in)</p> <p>spring-loaded terminals (push-in)</p>
wire length for motor unshielded maximum	100 m
type of connectable conductor cross-sections for main contacts	
<ul style="list-style-type: none"> • solid • finely stranded with core end processing • finely stranded without core end processing 	<p>1x (0.5 ... 4 mm²)</p> <p>1x (0.5 ... 2.5 mm²)</p> <p>1x (0.5 ... 4 mm²)</p>
connectable conductor cross-section for main contacts	
<ul style="list-style-type: none"> • solid or stranded • finely stranded with core end processing • finely stranded without core end processing 	<p>0.5 ... 4 mm²</p> <p>0.5 ... 2.5 mm²</p> <p>0.5 ... 4 mm²</p>
connectable conductor cross-section for auxiliary contacts	
<ul style="list-style-type: none"> • solid or stranded • finely stranded with core end processing • finely stranded without core end processing 	<p>0.5 ... 1.5 mm²</p> <p>0.5 ... 1 mm²</p> <p>0.5 ... 1.5 mm²</p>
type of connectable conductor cross-sections	

<ul style="list-style-type: none"> • for auxiliary contacts <ul style="list-style-type: none"> — solid — finely stranded with core end processing — finely stranded without core end processing • for AWG cables for auxiliary contacts 	1x (0.5 ... 1.5 mm ²), 2x (0.5 ... 1.5 mm ²) 1x (0,5 ... 1,0 mm ²), 2x (0,5 ... 1,0 mm ²) 1x (0.5 ... 1.5 mm ²), 2x (0.5 ... 1.5 mm ²) 1x (20 ... 16), 2x (20 ... 16)
AWG number as coded connectable conductor cross section for main contacts	20 ... 12
AWG number as coded connectable conductor cross section for auxiliary contacts	20 ... 16

UL/CSA ratings

yielded mechanical performance [hp]	
<ul style="list-style-type: none"> • for single-phase AC motor <ul style="list-style-type: none"> — at 230 V rated value • for 3-phase AC motor <ul style="list-style-type: none"> — at 200/208 V rated value — at 220/230 V rated value — at 460/480 V rated value 	0.125 hp 0.333 hp 0.333 hp 0.75 hp
operational current at AC at 480 V according to UL 508	2 A

Approvals Certificates

General Product Approval	EMV
---------------------------------	-----



EMV	Test Certificates	other	Railway
-----	-------------------	-------	---------



[Type Test Certificates/Test Report](#)

[Confirmation](#)

[Confirmation](#)



[Special Test Certificate](#)

Environment

[Environmental Confirmations](#)

Further information

Information on the packaging

<https://support.industry.siemens.com/cs/ww/en/view/109813875>

Information for data generation and storage

<https://support.industry.siemens.com/cs/ww/en/view/109995012>

Information- and Downloadcenter (Catalogs, Brochures,...)

<https://www.siemens.com/ic10>

Industry Mall (Online ordering system)

<https://mall.industry.siemens.com/mall/en/en/Catalog/product?mlfb=3RM1002-2AA14>

Cax online generator

<https://support.automation.siemens.com/WW/CAXorder/default.aspx?lang=en&mlfb=3RM1002-2AA14>

Service&Support (Manuals, Certificates, Characteristics, FAQs,...)

<https://support.industry.siemens.com/cs/ww/en/ps/3RM1002-2AA14>

Image database (product images, 2D dimension drawings, 3D models, device circuit diagrams, EPLAN macros, ...)

https://www.automation.siemens.com/bilddb/cax_de.aspx?mlfb=3RM1002-2AA14&lang=en

Characteristic curves

[https://curves.simaris.siemens.com/curves/<mmp_prod_noCOMP="HAUPT"></mmp_prod_no>](https://curves.simaris.siemens.com/curves/<mmp_prod_noCOMP=)

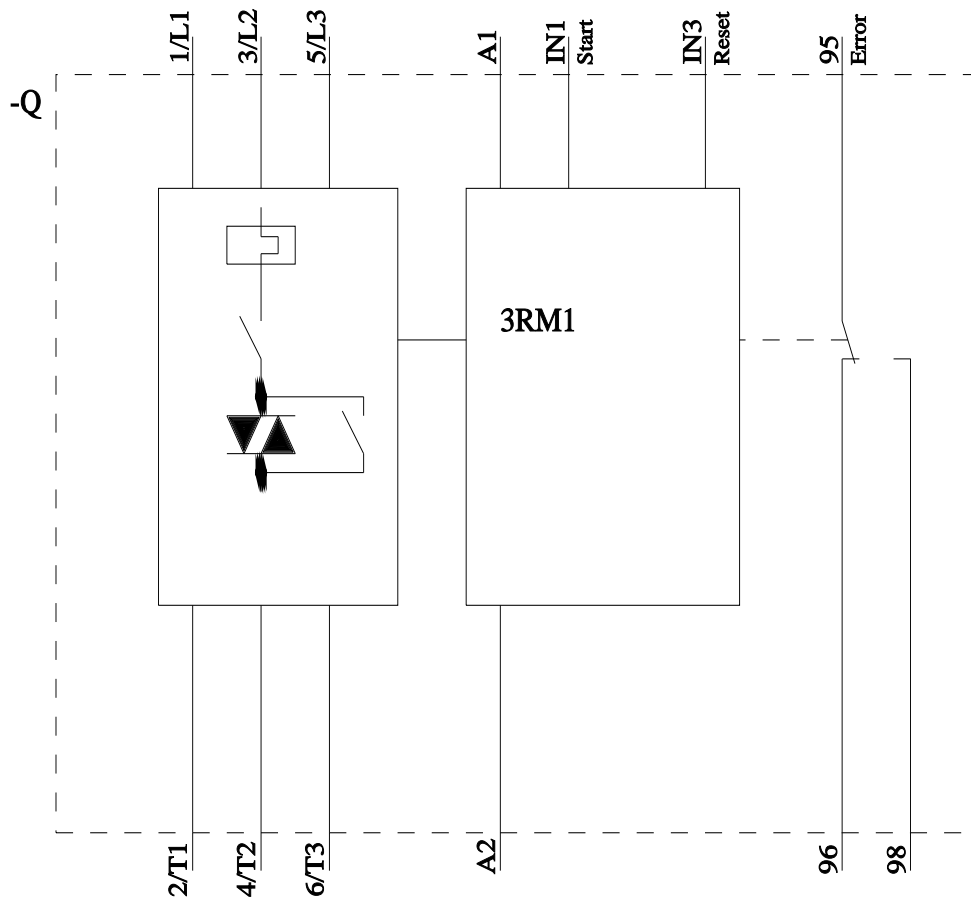
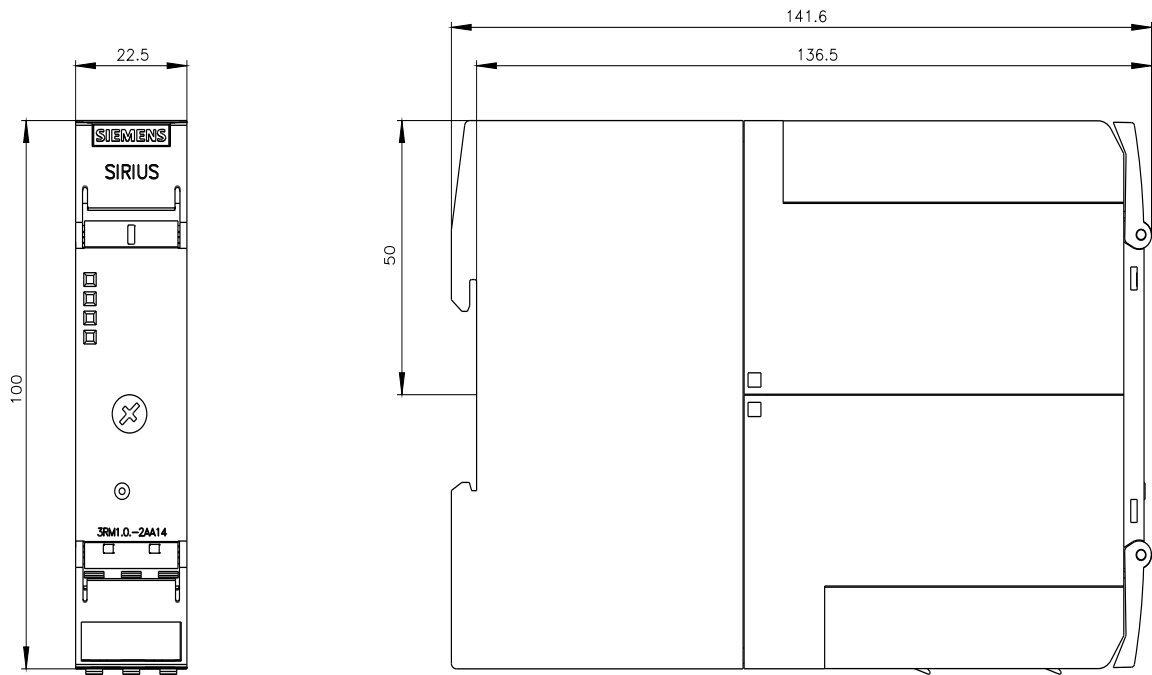

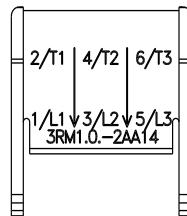
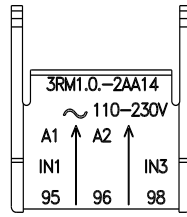
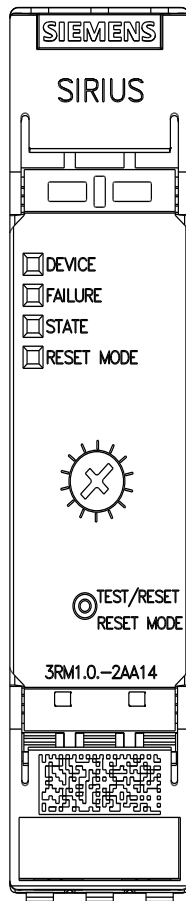

last modified:

4/23/2026 