



phase-out type solid-state contactor 3-phase 3RF2 AC 51 / 22 A / 40 °C 48-600 V / 4-30 V DC 2-phase controlled screw terminal blocking voltage 1200 V

product brand name	SIRIUS
product designation	solid-state contactor
design of the product	2-pole controlled
product type designation	3RF24
manufacturer's article number	
<ul style="list-style-type: none"> _2 of the accessories that can be ordered 	3RF2900-0EA18
product designation	
<ul style="list-style-type: none"> _2 of the accessories that can be ordered 	converter
General technical data	
product function	zero-point switching
power loss [W] for rated value of the current	
<ul style="list-style-type: none"> at AC in hot operating state 	44 W
<ul style="list-style-type: none"> at AC in hot operating state per pole 	14.67 W
<ul style="list-style-type: none"> without load current share typical 	0.9 W
insulation voltage rated value	600 V
degree of pollution	3
surge voltage resistance of main circuit rated value	6 kV
protection class IP	IP20
protection class IP on the front according to IEC 60529	IP20
shock resistance according to IEC 60068-2-27	15 g / 11 ms
vibration resistance according to IEC 60068-2-6	2 g
reference code according to IEC 81346-2	Q
Substance Prohibitance (Date)	07/01/2006
SVHC substance name	Lead CAS-No. 7439-92-1 Lead monoxide (lead oxide) CAS-No. 1317-36-8 2-methyl-1-(4-methylthiophenyl)-2-morpholinopropan-1-one CAS-No. 71868-10-5 Melamine CAS-No. 108-78-1 Dibutylbis(pentane-2,4-dionato-O,O')tin CAS-No. 22673-19-4
Net Weight	0.338 kg
Main circuit	
number of poles for main current circuit	3
number of NO contacts for main contacts	2
number of NC contacts for main contacts	0
type of voltage of the operating voltage	AC
operating voltage	
<ul style="list-style-type: none"> at AC 	
<ul style="list-style-type: none"> at 50 Hz rated value 	48 ... 600 V
<ul style="list-style-type: none"> at 60 Hz rated value 	48 ... 600 V
operating frequency rated value	50 ... 60 Hz

relative symmetrical tolerance of the operating frequency	10 %
operating range relative to the operating voltage at AC	
• at 50 Hz	40 ... 660 V
• at 60 Hz	40 ... 660 V
operational current	
• at AC-1 at 400 V rated value	22 A
• at AC-51 rated value	22 A
• at AC-51 according to IEC 60947-4-3	15 A
• according to UL 508 rated value	15 A
operational current minimum	500 mA
rate of voltage rise at the thyristor for main contacts maximum permissible	1 000 V/ μ s
blocking voltage at the thyristor for main contacts maximum permissible	1 200 V
reverse current of the thyristor	10 mA
derating temperature	40 °C
surge current resistance rated value	600 A
I²t value maximum	1 800 A ² ·s
Control circuit/ Control	
type of voltage of the control supply voltage	DC
control supply voltage 1 at DC rated value maximum permissible	30 V
control supply voltage 1 at DC	4 ... 30 V
control supply voltage at DC	
• initial value for signal <1> detection	4 V
• full-scale value for signal <0> recognition	1 V
symmetrical line frequency tolerance	5 Hz
control current at minimum control supply voltage	
• at DC	22 mA
control current at DC rated value	30 mA
ON-delay time	1 ms; additionally max. one half-wave
Installation/ mounting/ dimensions	
fastening method side-by-side mounting	Yes
fastening method	screw fixing and snap-on mounting on standard mounting rail 35 mm according to IEC 60715
design of the thread of the screw for securing the equipment	M4
height	100 mm
width	45 mm
depth	117 mm
Connections/ Terminals	
product component removable terminal for auxiliary and control circuit	Yes
type of electrical connection	
• for main current circuit	screw-type terminals
• for auxiliary and control circuit	screw-type terminals
type of connectable conductor cross-sections	
• for main contacts	
— solid	2x (1.5 ... 2.5 mm ²), 2x (2.5 ... 6 mm ²)
— finely stranded with core end processing	2x (1 ... 2.5 mm ²), 2x (2.5 ... 6 mm ²), 1x 10 mm ²
• for AWG cables for main contacts	2x (14 ... 10)
connectable conductor cross-section for main contacts	
• solid or stranded	0.5 ... 2.5 mm ²
• finely stranded with core end processing	0.5 ... 1.5 mm ²
• finely stranded without core end processing	0.5 ... 2.5 mm ²
type of connectable conductor cross-sections	
• for auxiliary and control contacts	
— solid	1x (0.5 ... 2.5 mm ²), 2x (0.5 ... 1 mm ²)
— finely stranded with core end processing	1x (0.5 ... 2.5 mm ²), 2x (0.5 ... 1 mm ²)
— finely stranded without core end processing	1x (0.5 ... 2.5 mm ²), 2x (0.5 ... 1 mm ²)

<ul style="list-style-type: none"> for AWG cables for auxiliary and control contacts 	1x (20 ... 12)
AWG number as coded connectable conductor cross section for main contacts	14 ... 10
tightening torque	
<ul style="list-style-type: none"> for main contacts with screw-type terminals 	2 ... 2.5 N·m
<ul style="list-style-type: none"> for auxiliary and control contacts with screw-type terminals 	0.5 ... 0.6 N·m
tightening torque [lbf·in]	
<ul style="list-style-type: none"> for main contacts with screw-type terminals 	18 ... 22 lbf·in
<ul style="list-style-type: none"> for auxiliary and control contacts with screw-type terminals 	7.5 ... 5.3 lbf·in
design of the thread of the connection screw	
<ul style="list-style-type: none"> for main contacts 	M4
<ul style="list-style-type: none"> of the auxiliary and control contacts 	M3
stripped length of the cable	
<ul style="list-style-type: none"> for main contacts 	10 mm
<ul style="list-style-type: none"> for auxiliary and control contacts 	7 mm
UL/CSA ratings	
operational current according to UL 508 rated value	15 A
Electrical Safety	
touch protection on the front according to IEC 60529	finger-safe, for vertical contact from the front
Ambient conditions	
installation altitude at height above sea level maximum	1 000 m
ambient temperature	
<ul style="list-style-type: none"> during operation 	-25 ... +60 °C
<ul style="list-style-type: none"> during storage 	-55 ... +80 °C
Electromagnetic compatibility	
conducted interference	
<ul style="list-style-type: none"> due to burst according to IEC 61000-4-4 	2 kV / 5 kHz, behavior criterion 2
<ul style="list-style-type: none"> due to conductor-earth surge according to IEC 61000-4-5 	2 kV, behavior criterion 2
<ul style="list-style-type: none"> due to conductor-conductor surge according to IEC 61000-4-5 	1 kV, behavior criterion 2
<ul style="list-style-type: none"> due to high-frequency radiation according to IEC 61000-4-6 	140 dBuV in the frequency range 0.15 ... 80 MHz, behavior criterion 1
electrostatic discharge according to IEC 61000-4-2	4 kV contact discharging / 8 kV air discharging, behavior criterion 2
conducted HF interference emissions according to CISPR11	Class A for industrial environment
field-bound HF interference emission according to CISPR11	Class A for industrial environment
Short-circuit protection, design of the fuse link	
manufacturer's article number	
<ul style="list-style-type: none"> of full range R fuse link for semiconductor protection at NH design usable 	3NE1814-0
<ul style="list-style-type: none"> of full range R fuse link for semiconductor protection at cylindrical design usable 	5SE1320: Maximum operating voltage 400 V!
<ul style="list-style-type: none"> of back-up R fuse link for semiconductor protection at NH design usable 	3NE8015-1
<ul style="list-style-type: none"> of back-up R fuse link for semiconductor protection at cylindrical design 10 x 38 mm usable 	3NC1032
<ul style="list-style-type: none"> of back-up R fuse link for semiconductor protection at cylindrical design 14 x 51 mm usable 	3NC1450
<ul style="list-style-type: none"> of back-up R fuse link for semiconductor protection at cylindrical design 22 x 58 mm usable 	3NC2250
manufacturer's article number of the gG fuse at NH design usable	
<ul style="list-style-type: none"> up to 460 V 	3NA3805: These fuses have a smaller rated current than the semiconductor relays
Approvals Certificates	
Environment	General Product Approval

[Environmental Confirmations](#)





[Type Test Certificates/Test Report](#)

[Confirmation](#)

[Miscellaneous](#)

[Confirmation](#)



Further information

Information on the packaging

<https://support.industry.siemens.com/cs/ww/en/view/109813875>

Information for data generation and storage

<https://support.industry.siemens.com/cs/ww/en/view/109995012>

Information- and Downloadcenter (Catalogs, Brochures,...)

<https://www.siemens.com/ic10>

Industry Mall (Online ordering system)

<https://mall.industry.siemens.com/mall/en/en/Catalog/product?mlfb=3RF2420-1AB45>

Cax online generator

<https://support.automation.siemens.com/WW/CAXorder/default.aspx?lang=en&mlfb=3RF2420-1AB45>

Service&Support (Manuals, Certificates, Characteristics, FAQs,...)

<https://support.industry.siemens.com/cs/ww/en/ps/3RF2420-1AB45>

Image database (product images, 2D dimension drawings, 3D models, device circuit diagrams, EPLAN macros, ...)

https://www.automation.siemens.com/bilddb/cax_de.aspx?mlfb=3RF2420-1AB45&lang=en

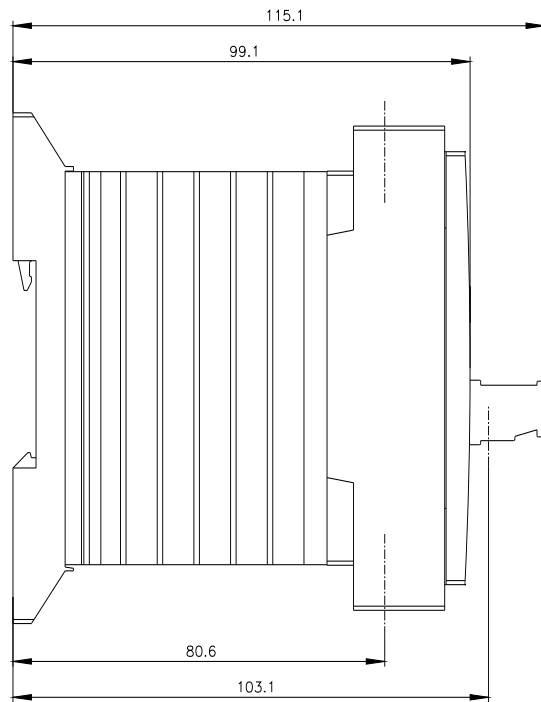
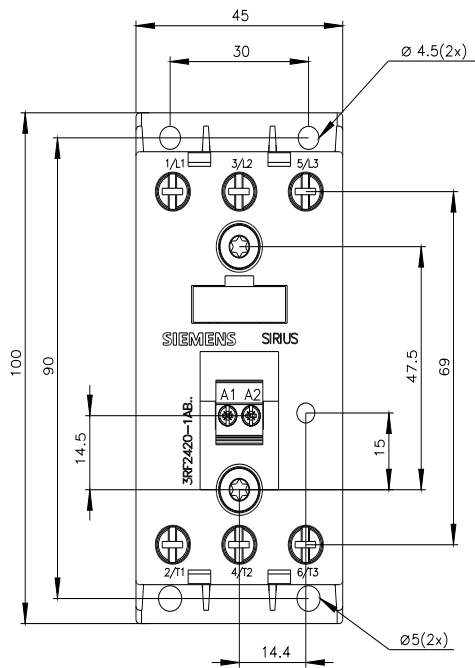

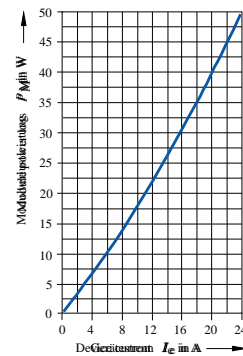
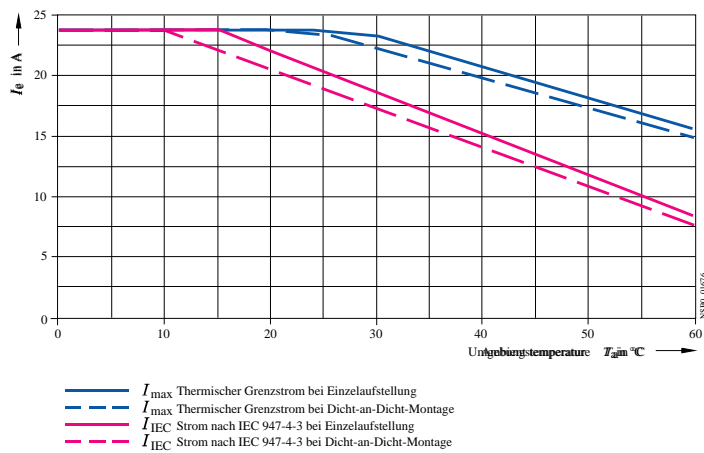
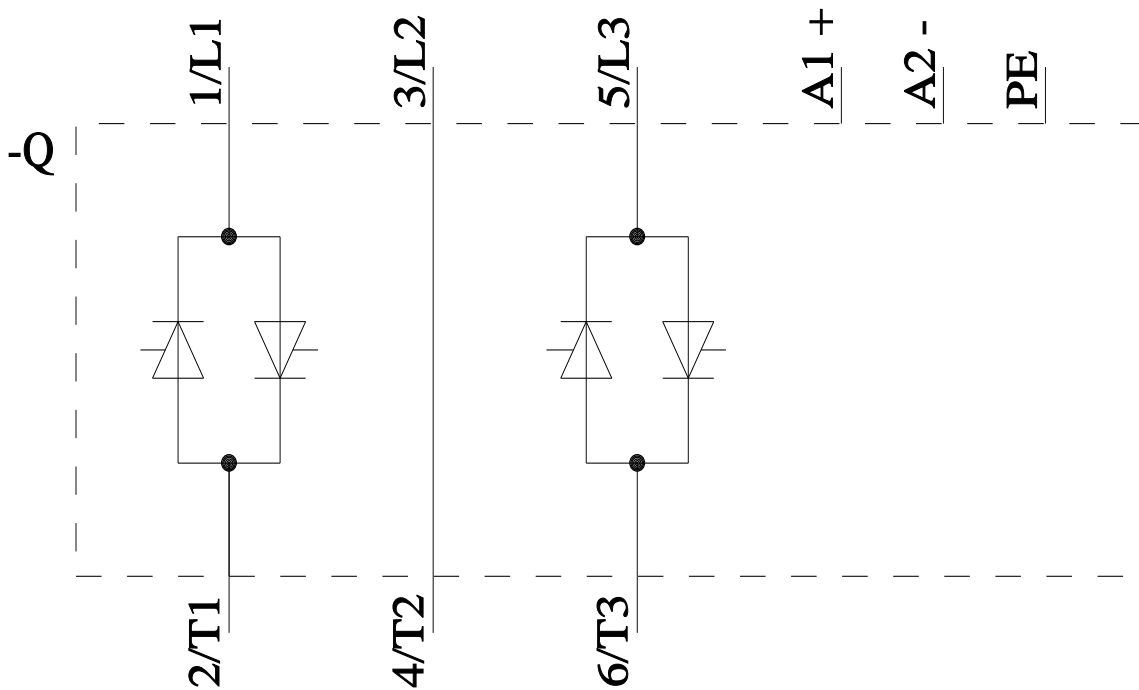

last modified:

4/4/2026