



Solid-state contactor 3-phase 3RF2 AC 51 / 10 A / 40 °C 48-600 V / 230 V AC 2-phase controlled screw terminal Blocking voltage 1200 V

product brand name	SIRIUS
product designation	solid-state contactor
design of the product	2-pole controlled
product type designation	3RF24
General technical data	
product function	zero-point switching
power loss [W] for rated value of the current	
• at AC in hot operating state	23 W
• at AC in hot operating state per pole	7.67 W
• without load current share typical	3.5 W
insulation voltage rated value	600 V
degree of pollution	3
surge voltage resistance of main circuit rated value	6 kV
protection class IP	IP20
protection class IP on the front according to IEC 60529	IP20
shock resistance according to IEC 60068-2-27	15g / 11 ms
vibration resistance according to IEC 60068-2-6	2g
reference code according to IEC 81346-2	Q
Substance Prohibitance (Date)	07/01/2006
SVHC substance name	Lead - 7439-92-1 Lead monoxide (lead oxide) - 1317-36-8 Dibutylbis(pentane-2,4-dionato-O,O')tin - 22673-19-4
Net Weight	0.294 kg
Main circuit	
number of poles for main current circuit	3
number of NO contacts for main contacts	2
number of NC contacts for main contacts	0
type of voltage of the operating voltage	AC
operating voltage	
• at AC	
— at 50 Hz rated value	48 ... 600 V
— at 60 Hz rated value	48 ... 600 V
operating frequency rated value	50 ... 60 Hz
relative symmetrical tolerance of the operating frequency	10 %
operating range relative to the operating voltage at AC	
• at 50 Hz	40 ... 660 V
• at 60 Hz	40 ... 660 V
operational current	
• at AC-1 at 400 V rated value	10.5 A
• at AC-51 rated value	10.5 A

<ul style="list-style-type: none"> at AC-51 according to IEC 60947-4-3 according to UL 508 rated value 	7 A 7 A
operational current minimum	100 mA
rate of voltage rise at the thyristor for main contacts maximum permissible	500 V/μs
blocking voltage at the thyristor for main contacts maximum permissible	1 200 V
reverse current of the thyristor	10 mA
derating temperature	40 °C
surge current resistance rated value	200 A
I²t value maximum	200 A ² ·s
Control circuit/ Control	
type of voltage of the control supply voltage	AC
control supply voltage 1 at AC <ul style="list-style-type: none"> at 50 Hz at 60 Hz 	180 ... 230 V 180 ... 230 V
control supply voltage frequency <ul style="list-style-type: none"> 1 rated value 2 rated value 	45 Hz 66 Hz
control supply voltage at AC <ul style="list-style-type: none"> at 50 Hz full-scale value for signal<0> recognition at 60 Hz full-scale value for signal<0> recognition 	40 V 180 V
control supply voltage <ul style="list-style-type: none"> at AC initial value for signal <1> detection 	180 V
symmetrical line frequency tolerance	5 Hz
control current at minimum control supply voltage <ul style="list-style-type: none"> at AC 	2 mA
control current at AC rated value	15 mA
ON-delay time	40 ms; additionally max. one half-wave
Installation/ mounting/ dimensions	
fastening method side-by-side mounting	Yes
fastening method	screw fixing and snap-on mounting on standard mounting rail 35 mm according to IEC 60715
design of the thread of the screw for securing the equipment	M4
height	95 mm
width	45 mm
depth	96.5 mm
Connections/ Terminals	
product component removable terminal for auxiliary and control circuit	Yes
type of electrical connection <ul style="list-style-type: none"> for main current circuit for auxiliary and control circuit 	screw-type terminals screw-type terminals
type of connectable conductor cross-sections <ul style="list-style-type: none"> for main contacts <ul style="list-style-type: none"> — solid — finely stranded with core end processing for AWG cables for main contacts 	2x (1.5 ... 2.5 mm ²), 2x (2.5 ... 6 mm ²) 2x (1 ... 2.5 mm ²), 2x (2.5 ... 6 mm ²), 1x 10 mm ² 2x (14 ... 10)
connectable conductor cross-section for main contacts <ul style="list-style-type: none"> solid or stranded finely stranded with core end processing 	1.5 ... 6 mm ² 1 ... 10 mm ²
type of connectable conductor cross-sections <ul style="list-style-type: none"> for auxiliary and control contacts <ul style="list-style-type: none"> — solid — finely stranded with core end processing — finely stranded without core end processing for AWG cables for auxiliary and control contacts 	1x (0.5 ... 2.5 mm ²), 2x (0.5 ... 1 mm ²) 1x (0.5 ... 2.5 mm ²), 2x (0.5 ... 1 mm ²) 1x (0.5 ... 2.5 mm ²), 2x (0.5 ... 1 mm ²) 1x (20 ... 12)
AWG number as coded connectable conductor cross section for main contacts	14 ... 10

tightening torque	
<ul style="list-style-type: none"> for main contacts with screw-type terminals for auxiliary and control contacts with screw-type terminals 	<p>2 ... 2.5 N·m</p> <p>0.5 ... 0.6 N·m</p>
tightening torque [lbf·in]	
<ul style="list-style-type: none"> for main contacts with screw-type terminals for auxiliary and control contacts with screw-type terminals 	<p>18 ... 22 lbf·in</p> <p>7.5 ... 5.3 lbf·in</p>
design of the thread of the connection screw	
<ul style="list-style-type: none"> for main contacts of the auxiliary and control contacts 	<p>M4</p> <p>M3</p>
stripped length of the cable	
<ul style="list-style-type: none"> for main contacts for auxiliary and control contacts 	<p>10 mm</p> <p>7 mm</p>

Electrical Safety

protection class IP on the front according to IEC 60529	IP20
--	------

touch protection on the front according to IEC 60529	finger-safe, for vertical contact from the front
---	--

Ambient conditions

installation altitude at height above sea level maximum	1 000 m
---	---------

ambient temperature	
<ul style="list-style-type: none"> during operation during storage 	<p>-25 ... +60 °C</p> <p>-55 ... +80 °C</p>

Electromagnetic compatibility

conducted interference	
<ul style="list-style-type: none"> due to burst according to IEC 61000-4-4 due to conductor-earth surge according to IEC 61000-4-5 due to conductor-conductor surge according to IEC 61000-4-5 due to high-frequency radiation according to IEC 61000-4-6 	<p>2 kV / 5 kHz, behavior criterion 2</p> <p>2 kV, behavior criterion 2</p> <p>1 kV, behavior criterion 2</p> <p>140 dBuV in the frequency range 0.15 ... 80 MHz, behavior criterion 1</p>

electrostatic discharge according to IEC 61000-4-2	4 kV contact discharging / 8 kV air discharging, behavior criterion 2
---	---

conducted HF interference emissions according to CISPR11	Class A for industrial environment
---	------------------------------------

field-bound HF interference emission according to CISPR11	Class A for industrial environment
--	------------------------------------

Short-circuit protection, design of the fuse link

<p>manufacturer's article number</p> <ul style="list-style-type: none"> of full range R fuse link for semiconductor protection at NH design usable of full range R fuse link for semiconductor protection at cylindrical design usable of back-up R fuse link for semiconductor protection at NH design usable of back-up R fuse link for semiconductor protection at cylindrical design 10 x 38 mm usable of back-up R fuse link for semiconductor protection at cylindrical design 14 x 51 mm usable of back-up R fuse link for semiconductor protection at cylindrical design 22 x 58 mm usable 	<p>3NE1813-0</p> <p>5SE1310: Maximum operating voltage 400 V!</p> <p>3NE8015-1</p> <p>3NC1016</p> <p>3NC1420</p> <p>3NC2220</p>
--	---

<p>manufacturer's article number of the gG fuse at NH design usable</p> <ul style="list-style-type: none"> up to 460 V 	<p>3NA3801: These fuses have a smaller rated current than the semiconductor relays</p>
---	--

Approvals Certificates

Environment	General Product Approval
--------------------	---------------------------------



[Environmental Confirmations](#)



Test Certificates	other
--------------------------	--------------



Further information

Information on the packaging

<https://support.industry.siemens.com/cs/ww/en/view/109813875>

Information for data generation and storage

<https://support.industry.siemens.com/cs/ww/en/view/109995012>

Information- and Downloadcenter (Catalogs, Brochures,...)

<https://www.siemens.com/ic10>

Industry Mall (Online ordering system)

<https://mall.industry.siemens.com/mall/en/en/Catalog/product?mlfb=3RF2410-1AB55>

Cax online generator

<https://support.automation.siemens.com/WW/CAXorder/default.aspx?lang=en&mlfb=3RF2410-1AB55>

Service&Support (Manuals, Certificates, Characteristics, FAQs,...)

<https://support.industry.siemens.com/cs/ww/en/ps/3RF2410-1AB55>

Image database (product images, 2D dimension drawings, 3D models, device circuit diagrams, EPLAN macros, ...)

https://www.automation.siemens.com/bilddb/cax_de.aspx?mlfb=3RF2410-1AB55&lang=en

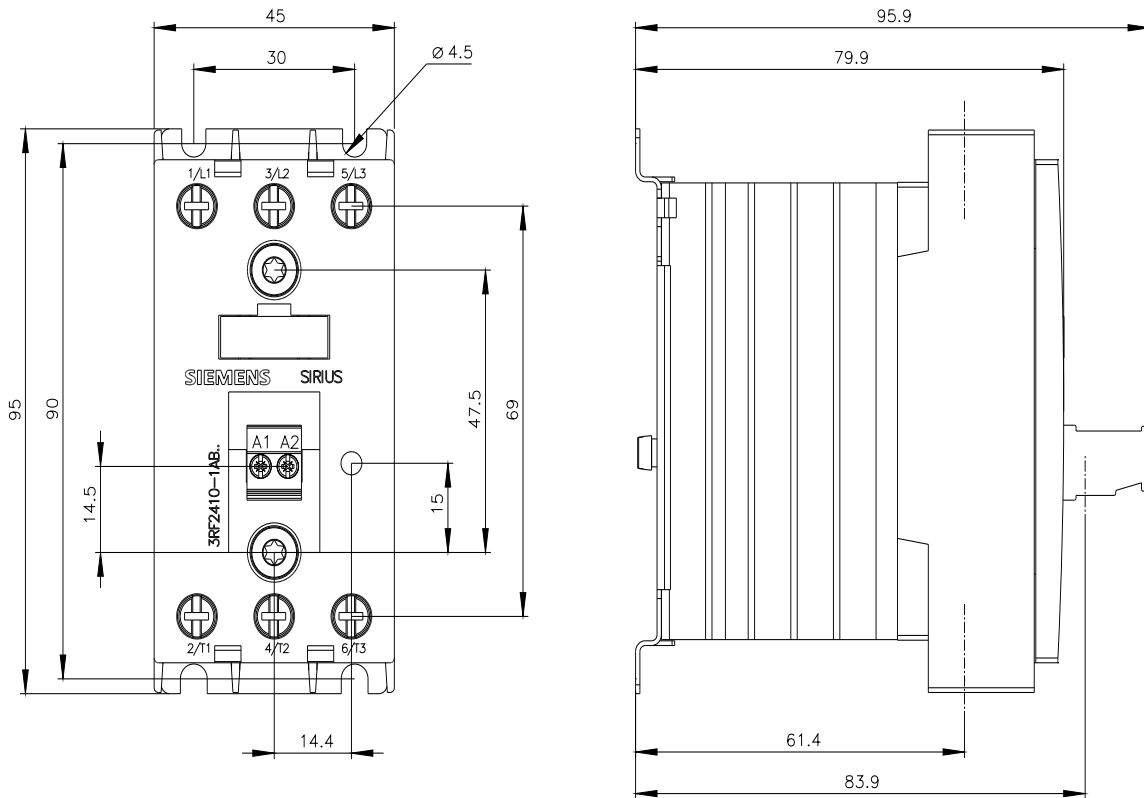

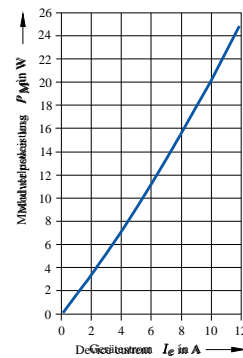
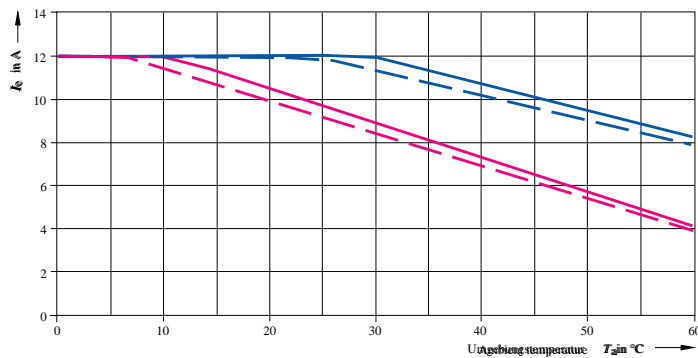

- I_{max} Thermischer Grenzstrom bei Einzelaufstellung
- - - I_{max} Thermischer Grenzstrom bei Dicht-an-Dicht-Montage
- I_{IEC} Strom nach IEC 947-4-3 bei Einzelaufstellung
- - - I_{IEC} Strom nach IEC 947-4-3 bei Dicht-an-Dicht-Montage

last modified:

2/10/2026