



RP604x Series

Ultra-low Quiescent Current ($I_Q = 0.3 \mu\text{A}$), 300 mA, Buck-Boost DC/DC Converter

No. EA-415-251006

OVERVIEW

The RP604x is a buck-boost converter featuring a minimum supply current and a high efficiency at low-load. The device operates at the low operating quiescent current ($I_Q = 0.3 \mu\text{A}$) to make the most of battery life for the battery driver operated intermittently.

KEY BENEFITS

- The low supply current ($I_Q = 0.3 \mu\text{A}$) can achieve making battery life longer and battery's size-reduction.
- Wide range of input voltage (1.8 V to 5.5 V) can support for every battery from a coin-type battery to a USB port.
- Selectable package: WLCSP-20-P2 or DFN(PL)2730-12

KEY SPECIFICATIONS

- Input Voltage: 1.8 V to 5.5 V
- Output Voltage: 1.6 V to 5.2 V, 0.1 V step
- Output Voltage Accuracy: $\pm 1.5\%$
- Maximum Output Current: 300 mA at Buck
- Built-in Driver On-resistance (RP604Z, $V_{IN} = 3.6 \text{ V}$): PMOS = Typ.0.12 Ω , NMOS = Typ. 0.12 Ω
- Operating Quiescent Current (I_Q): 0.3 μA
- Standby Current: 0.01 μA
- Protection Features: UVLO, OVP, LX Peak Current, and Thermal Shutdown

TYPICAL CHARACTERISTICS

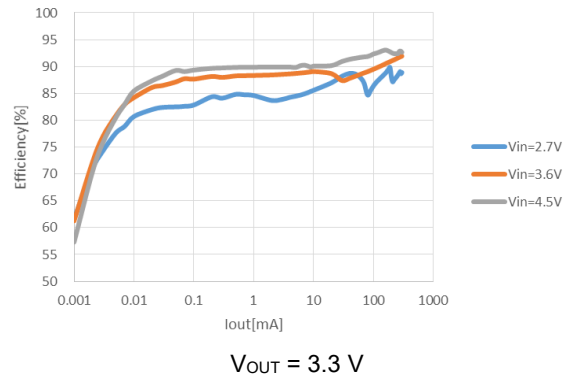

PACKAGES

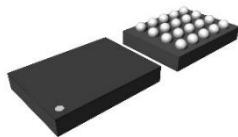

WLCSP-20-P2
1.71 x 2.315 x 0.40⁽¹⁾ mm
(¹) maximum dimension

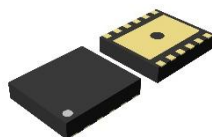

DFN(PL)2730-12
2.70 x 3.00 x 0.6⁽¹⁾ mm
(¹) maximum dimension

OPTIONAL FUNCTIONS

The auto-discharge function and the set output voltage (V_{SET}) are user-selectable options.

Product Name	Auto-discharge Function	V_{SET}
RP604xxx1A	Disable	1.6 V to 5.2 V (0.1 V step)
RP604xxx1B	Enable	

APPLICATIONS

- Wearable Appliances: SmartWatch, SmartBand, Healthcare
- Li-ion/Coin Battery-used Equipment
- Low-power Wireless Communication Equipment: Bluetooth® Low Energy, ZigBee, WiSunm, ANT
- Low-power Devices for CPU, Memory, Sensor Device, Energy Harvesting

SELECTION GUIDE

The set output voltage, the auto-discharge function⁽¹⁾ and the package are user-selectable options.

Selection Guide

Product Name	Package	Quantity per Reel	Pb Free	Halogen Free
RP604Zxx1\$-E2-F	WLCSP-20-P2	5,000 pcs	Yes	Yes
RP604Zxx1\$-E2-T	WLCSP-20-P2	5,000 pcs	Yes	Yes
RP604Kxx1\$-TR	DFN(PL)2730-12	5,000 pcs	Yes	Yes

xx: Specify the set output voltage (V_{SET}) within the range of 1.6 V (16) to 5.2 V (52) in 0.1 V steps.

\$: Specify the auto-discharge function.

Version	Auto-discharge Function	V_{SET}
A	Disable	1.6 V to 5.2 V
B	Enable	

BLOCK DIAGRAM

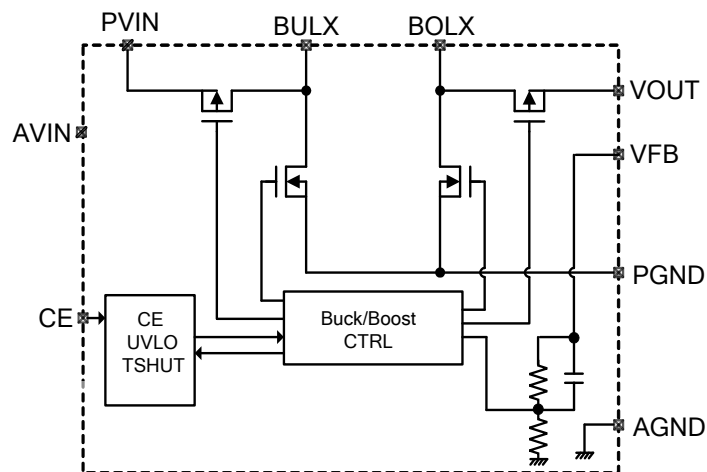

RP604xxx1A/ RP604xxx1B Block Diagram

⁽¹⁾ Auto-discharge function quickly lowers the output voltage to 0 V, when the chip enable signal is switched from the active mode to the standby mode, by releasing the electrical charge accumulated in the external capacitor.

PIN DESCRIPTIONS



WLCSP-20-P2 Pin Configuration

WLCSP-20-P2 Pin Description

Pin No.	Pin Name	Description
A5, B5, C5	VOUT	Output Voltage Pin
A4, B4, C4	BOLX	Boost Switching Output Pin
A3, B3, C3, D3	PGND	Power GND Pin
A2, B2, C2	BULX	Buck Switching Output Pin
A1, B1, C1	PVIN	Power Input Voltage Pin
D1	AVIN	Analog Power Input Voltage Pin
D2	CE	Chip Enable Pin, Active-high
D4	AGND	Analog GND Pin
D5	VFB	Output Voltage Feedback Pin

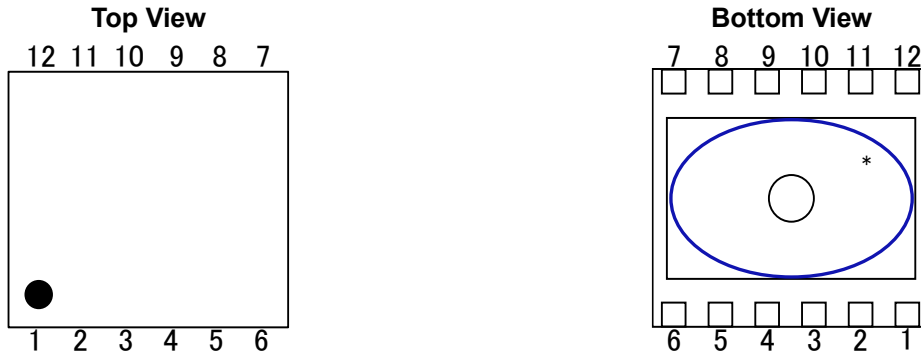

DFN(PL)2730-12 Pin Configuration

DFN(PL)2730-12 Pin Description

Pin No.	Pin Name	Description
1	AVIN	Analog Power Input Voltage Pin
2	CE	Chip Enable Pin, Active-high
3	PGND	Power GND Pin
4	PGND	Power GND Pin
5	AGND	Analog GND Pin
6	VFB	Output Voltage Feedback Pin
7	VOUT	Output Voltage Pin
8	BOLX	Boost Switching Output Pin
9	PGND	Power GND Pin
10	PGND	Power GND Pin
11	BULX	Buck Switching Output Pin
12	PVIN	Power Input Voltage Pin

* The tab on the bottom of the package shown by blue circle is a substrate potential (GND). It is recommended that this tab be connected to the ground plane on the board but it is possible to leave the tab floating.

ABSOLUTE MAXIMUM RATINGS

Absolute Maximum Ratings

(GND = 0 V)

Symbol	Parameter		Rating	Unit	
V_{IN}	A/PVIN Pin Voltage		-0.3 to 6.5	V	
V_{BULX}	BULX Pin Voltage		-0.3 to $V_{IN} + 0.3$	V	
V_{BOLX}	BOLX Pin Voltage		-0.3 to $V_{OUT} + 0.3$	V	
V_{CE}	CE Pin Voltage		-0.3 to 6.5	V	
V_{OUT}	VOUT Pin Voltage		-0.3 to 6.5	V	
V_{FB}	VFB Pin Voltage		-0.3 to 6.5	V	
I_{LX}	BULX/BOLX Pin Output Current		900	mA	
P_D	Power Dissipation ⁽¹⁾	WLCSP-20-P2	JEDEC STD. 51-9	1490	mW
		DFN(PL)2730-12	JEDEC STD. 51-7	3100	mW
T_j	Junction Temperature Range		-40 to 125	°C	
T_{stg}	Storage Temperature Range		-55 to 125	°C	

ABSOLUTE MAXIMUM RATINGS

Electronic and mechanical stress momentarily exceeded absolute maximum ratings may cause permanent damage and may degrade the life time and safety for both device and system using the device in the field. The functional operation at or over these absolute maximum ratings are not assured.

RECOMMENDED OPERATING CONDITIONS

Recommended Operating Conditions

Symbol	Parameter	Rating	Unit
V_{IN}	Input Voltage	1.8 to 5.5	V
T_a	Operating Temperature Range	-40 to 85	°C

RECOMMENDED OPERATING CONDITIONS

All of electronic equipment should be designed that the mounted semiconductor devices operate within the recommended operating conditions. The semiconductor devices cannot operate normally over the recommended operating conditions, even if they are used over such conditions by momentary electronic noise or surge. And the semiconductor devices may receive serious damage when they continue to operate over the recommended operating conditions.

⁽¹⁾ Refer to *POWER DISSIPATION* for detailed information.

ELECTRICAL CHARACTERISTICS

The specifications surrounded by are guaranteed by design engineering at $-40^{\circ}\text{C} \leq T_a \leq 85^{\circ}\text{C}$.

RP604Z/K Electrical Characteristics

($T_a = 25^{\circ}\text{C}$)

Symbol	Parameter	Test Conditions/Comments	Min.	Typ.	Max.	Unit
V_{OUT}	Output Voltage	$V_{\text{IN}} = V_{\text{CE}} = 3.6 \text{ V}$	x 0.985		x 1.015	V
I_{Q}	Operating Quiescent Current	$V_{\text{IN}} = V_{\text{CE}} = V_{\text{OUT}} = 3.6 \text{ V}$, $V_{\text{SET}} = 3.3 \text{ V}$ at rest		0.3		μA
I_{STANDBY}	Standby Current	$V_{\text{IN}} = 5.5 \text{ V}$, $V_{\text{CE}} = 0 \text{ V}$		0.01	1	μA
I_{CEH}	CE Pin Input Current, High	$V_{\text{IN}} = V_{\text{CE}} = 5.5 \text{ V}$	-0.025	0	0.025	μA
I_{CEL}	CE Pin Input Current, Low	$V_{\text{IN}} = 5.5 \text{ V}$, $V_{\text{CE}} = 0 \text{ V}$	-0.025	0	0.025	μA
I_{VOUTH}	VFB Pin Input Current, High	$V_{\text{IN}} = V_{\text{FB}} = 5.5 \text{ V}$, $V_{\text{CE}} = 0 \text{ V}$	-0.025	0	0.025	μA
I_{VOUTL}	VFB Pin Input Current, Low	$V_{\text{IN}} = 5.5 \text{ V}$, $V_{\text{CE}} = V_{\text{FB}} = 0 \text{ V}$	-0.025	0	0.025	μA
V_{OVP}	OVP Threshold Voltage	$V_{\text{IN}} = 3.6 \text{ V}$, rising (detection)		6.0		V
		$V_{\text{IN}} = 3.6 \text{ V}$, falling (release)		5.5		V
R_{DISN}	Auto-discharge NMOS On-resistance ⁽¹⁾	$V_{\text{IN}} = 3.6 \text{ V}$, $V_{\text{CE}} = 0 \text{ V}$		100		Ω
V_{CEH}	CE Pin Input Voltage, High	$V_{\text{IN}} = 5.5 \text{ V}$	1.0			V
V_{CEL}	CE Pin Input Voltage, Low	$V_{\text{IN}} = 2.0 \text{ V}$			0.4	V
R_{ONP}	PMOS On-resistance	RP604Z $V_{\text{IN}} = 3.6 \text{ V}$, $I_{\text{LX}} = -100 \text{ mA}$		0.12		Ω
		RP604K $V_{\text{IN}} = 3.6 \text{ V}$, $I_{\text{LX}} = -100 \text{ mA}$		0.15		Ω
R_{ONN}	NMOS On-resistance	RP604Z $V_{\text{IN}} = 3.6 \text{ V}$, $I_{\text{LX}} = -100 \text{ mA}$		0.12		Ω
		RP604K $V_{\text{IN}} = 3.6 \text{ V}$, $I_{\text{LX}} = -100 \text{ mA}$		0.15		Ω
T_{TSD}	Thermal Shutdown Threshold Temperature	T_{j} , rising (detection)		140		$^{\circ}\text{C}$
T_{TSR}		T_{j} , falling (release)		100		$^{\circ}\text{C}$
t_{START}	Soft-start Time	$V_{\text{IN}} = V_{\text{CE}} = 3.6 \text{ V}$		20		ms
I_{LXLIM}	LX Current Limit	$V_{\text{IN}} = V_{\text{CE}} = 3.6 \text{ V}$	600	900		mA
V_{UVLOF}	UVLO Threshold Voltage	$V_{\text{IN}} = V_{\text{CE}}$, falling (detection)	1.40	1.50	1.65	V
V_{UVLOR}		$V_{\text{IN}} = V_{\text{CE}}$, rising (release)	1.55	1.65	1.80	V

All test items listed under Electrical Characteristics are done under the pulse load condition ($T_{\text{j}} \approx T_a = 25^{\circ}\text{C}$). Unless otherwise noted, the test runs with "Open-loop Control" ($\text{GND} = 0 \text{ V}$).

⁽¹⁾ RP604xxx1B only

Product-specific Electrical Characteristics (Ta = 25° C)

Product Name	V _{OUT} [V]		
	Min.	Typ.	Max.
RP604x161x	1.576	1.600	1.624
RP604x171x	1.675	1.700	1.725
RP604x181x	1.773	1.800	1.827
RP604x191x	1.872	1.900	1.928
RP604x201x	1.970	2.000	2.030
RP604x211x	2.069	2.100	2.131
RP604x221x	2.167	2.200	2.233
RP604x231x	2.266	2.300	2.334
RP604x241x	2.364	2.400	2.436
RP604x251x	2.463	2.500	2.537
RP604x261x	2.561	2.600	2.639
RP604x271x	2.660	2.700	2.740
RP604x281x	2.758	2.800	2.842
RP604x291x	2.857	2.900	2.943
RP604x301x	2.955	3.000	3.045
RP604x311x	3.054	3.100	3.146
RP604x321x	3.152	3.200	3.248
RP604x331x	3.251	3.300	3.349
RP604x341x	3.349	3.400	3.451
RP604x351x	3.448	3.500	3.552
RP604x361x	3.546	3.600	3.654
RP604x371x	3.645	3.700	3.755
RP604x381x	3.743	3.800	3.857
RP604x391x	3.842	3.900	3.958
RP604x401x	3.940	4.000	4.060
RP604x411x	4.039	4.100	4.161
RP604x421x	4.137	4.200	4.263
RP604x431x	4.236	4.300	4.364
RP604x441x	4.334	4.400	4.466
RP604x451x	4.433	4.500	4.567
RP604x461x	4.531	4.600	4.669
RP604x471x	4.630	4.700	4.770
RP604x481x	4.728	4.800	4.871
RP604x491x	4.827	4.900	4.973
RP604x501x	4.925	5.000	5.074
RP604x511x	5.024	5.100	5.176
RP604x521x	5.122	5.200	5.277

THEORY OF OPERATION

Soft-start Time

Starting-up with CE Pin

The IC starts to operate when the CE pin voltage (V_{CE}) exceeds the threshold voltage. The threshold voltage is preset between CE "H" input voltage (V_{CEH}) and CE "L" input voltage (V_{CEL}). After the start-up of the IC, soft-start circuit starts to operate. Then, after a certain period of time, the reference voltage (V_{REF}) in the IC gradually increases up to the specified value. Switching starts when V_{REF} reaches the preset voltage, and after that the output voltage rises accompanying V_{REF} 's increase. Soft-start time (t_{START}) starts when soft-start circuit is activated, and ends when the reference voltage reaches the specified voltage. Soft start time is not always equal to the turn-on speed of the DC/DC converter. Note that the turn-on speed could be affected by the power supply capacity, the output current, the inductance value and the C_{OUT} value.

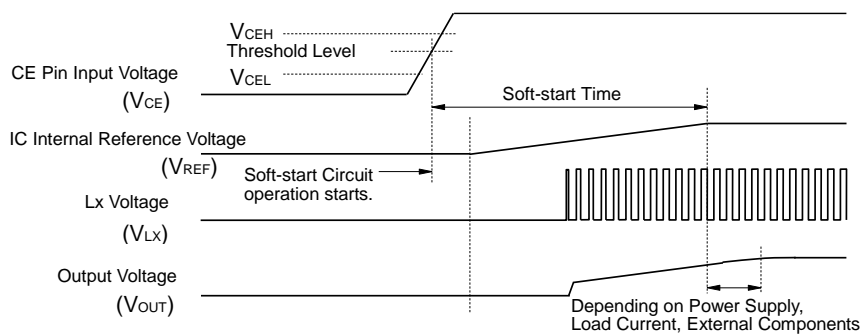

Timing Chart: Starting-up with CE Pin

Starting-up with Power Supply

After the power-on, when V_{IN} exceeds the UVLO released voltage (V_{UVLOR}), the IC starts to operate. Then, soft-start circuit starts to operate and after a certain period of time, V_{REF} gradually increases up to the specified value. Switching starts when V_{REF} reaches the preset voltage, and after that the output voltage rises accompanying V_{REF} 's increase. Soft-start time starts when soft-start circuit is activated, and ends when V_{REF} reaches the specified voltage. Note that the turn-on speed of V_{OUT} could be affected by the power supply capacity, the output current, the inductance value, the C_{OUT} value and the turn-on speed of V_{IN} determined by C_{IN} .

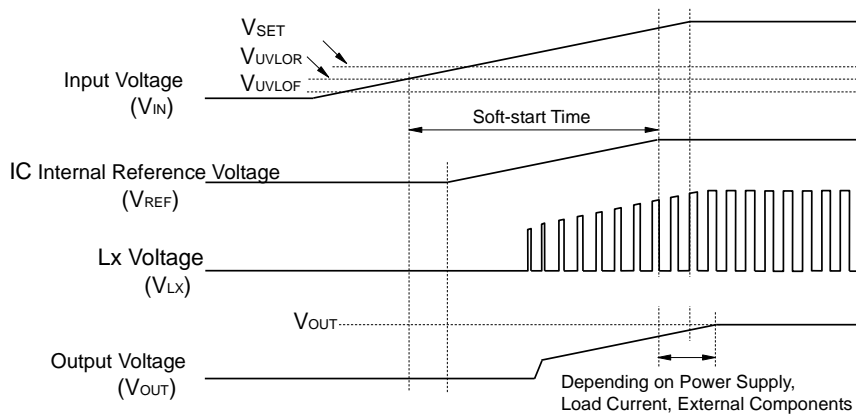

Timing Chart: Starting-up with Power Supply

Undervoltage Lockout (UVLO) Circuit

If the V_{IN} becomes lower than the UVLO detector threshold (V_{UVLOF}), the UVLO circuit starts to operate, V_{REF} stops, and P-channel and N-channel built-in switch transistors turn “OFF”. As a result, V_{OUT} drops according to the C_{OUT} capacitance value and the load. To restart the operation, V_{IN} needs to be higher than V_{UVLOR} .

Overvoltage Protection (OVP) Circuit

If the V_{OUT} becomes higher than the OVP detector threshold (V_{OVP}), the OVP circuit starts to operate, P-channel and N-channel built-in switch transistors turn “OFF”. As a result, V_{OUT} drops according to the C_{OUT} capacitance value and the load.

Overcurrent Protection Circuit

Overcurrent protection circuit supervises the inductor peak current (the peak current flowing through Pch Tr (SW1) in each switching cycle, and if the current exceeds the BULX current limit (I_{LXLIM}), it turns off Pch Tr (SW1). I_{LXLIM} of the RP604x is set to Typ. 0.9 A.

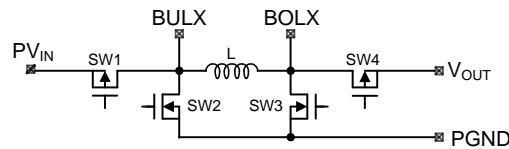

Simplified Diagram of Output Switches

VFM Mode

The VFM (Variable Frequency Modulation) mode is adopted as a switching method to achieve a high efficiency under light load conditions. A switching frequency varies depending on values of input voltage (V_{IN}), output voltage (V_{OUT}), and output current (I_{OUT}). Check the actual characteristics to avoid the switching noise.

A switching starts when V_{OUT} drops below the lower-limit reference voltage (V_{REFL}). When V_{OUT} exceeds the upper-limit reference voltage (V_{REFH}), a constant voltage is output by a hysteresis control which stops the switching.

In order to operate within the rated characteristic of inductor and avoid the deteriorated band frequency of DC superimposed characteristics, when the inductor current (I_L) exceeds LX current limit (I_{LXLIM}), the operation shifts to off-cycle. And when I_L drops below the valley current limit (I_{LXVAL}), the operation shifts to on-cycle.

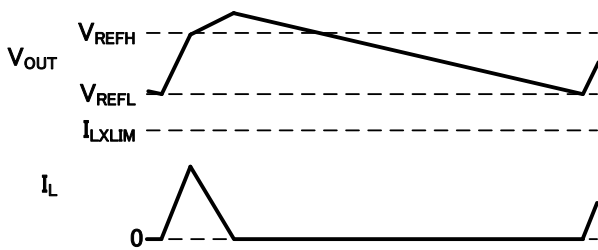

No Load

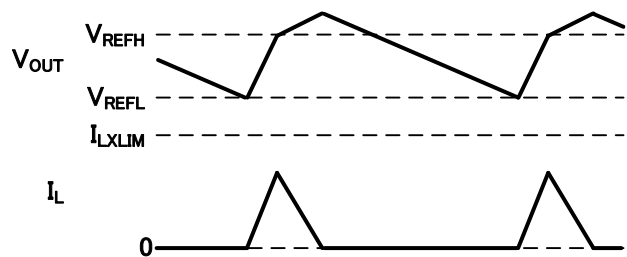

Light Load

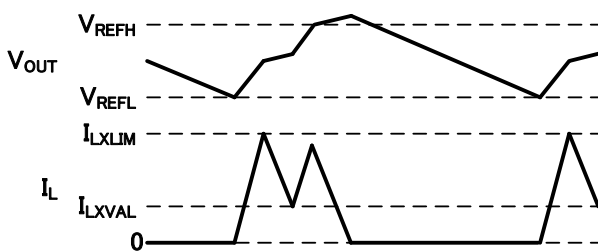

Medium Load

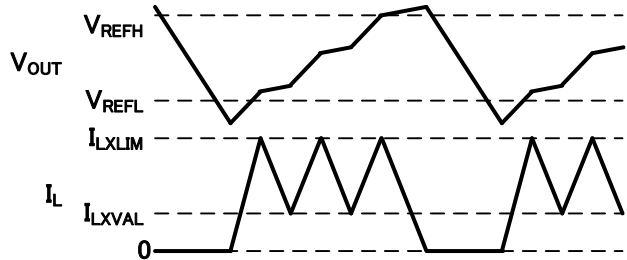

Heavy Load

APPLICATION INFORMATION

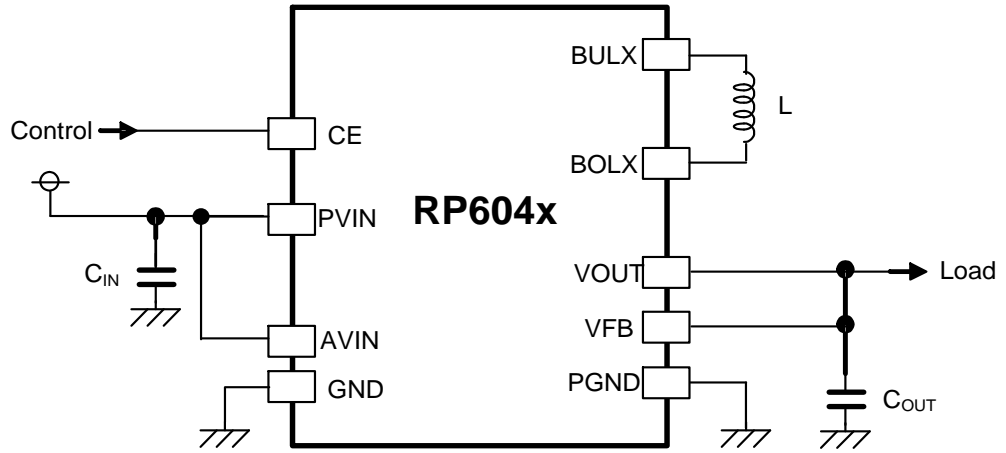

RP604x Typical Application Circuit

Recommended External Components

Symbol	Description
C _{IN}	10 μF or more, Ceramic Capacitor
C _{OUT}	22 μF, Ceramic Capacitor
L	2.2 μH, Inductor

TECHNICAL NOTES

The performance of a power source circuit using this device is highly dependent on a peripheral circuit. A peripheral component or the device mounted on PCB should not exceed a rated voltage, a rated current or a rated power. When designing a peripheral circuit, please be fully aware of the following points. Refer to *PCB Layout* below.

- Use ceramic capacitors with a low equivalent series resistance (ESR), considering the bias characteristics and input/ output voltage.
- When the built-in switches are turned off, the inductor may generate a spike-shaped high voltage. Use the high-breakdown voltage capacitor (C_{OUT}) which output voltage is 1.5 times or more than the set output voltage.
- Use an inductor that has a low DC resistance, has an enough tolerable current and is less likely to cause magnetic saturation. If the inductance value is extremely small, the peak current of L_X may increase. When the peak current of L_X reaches to the L_X limit current (I_{LXLIM}), overcurrent protection circuit starts to operate. When selecting the inductor, consider the peak current of LX pin (I_{LXMAX}).
- When an intermediate voltage other than V_{IN} or GND is input to the CE pin, a supply current may be increased with a through current of a logic circuit in the IC. The CE pin is neither pulled up nor pulled down, therefore an operation is not stable at open.

PCB Layout

RP604Z (Package: WLCSP-20-P2) PCB Layout

Topside

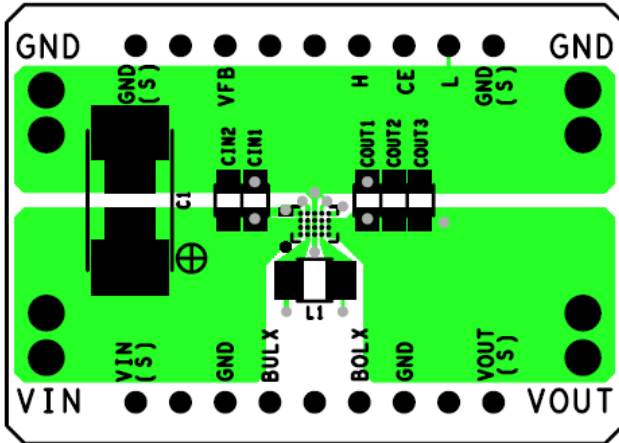

Backside

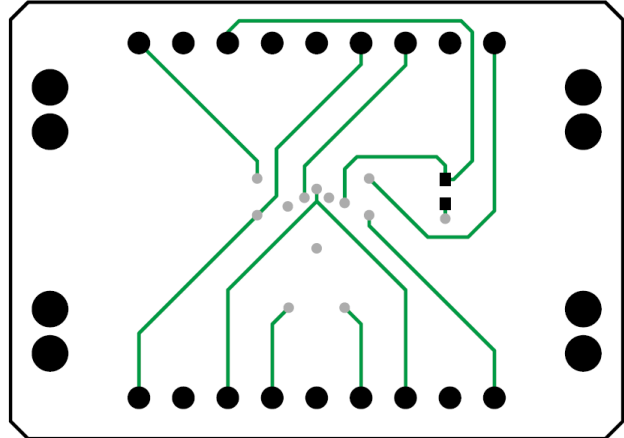

RP604K (Package: DFN(PL)2730-12) PCB Layout

Topside

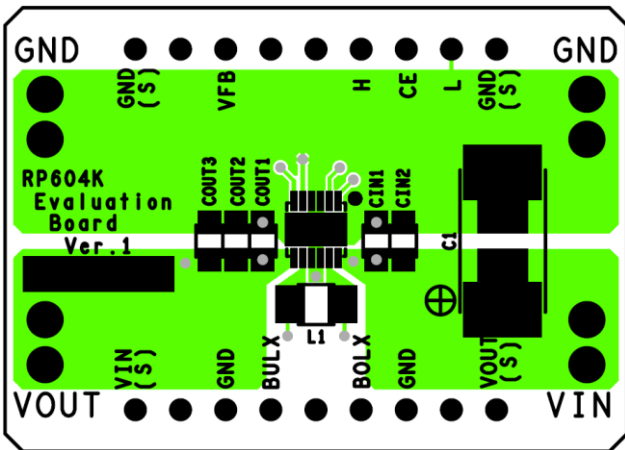

Backside

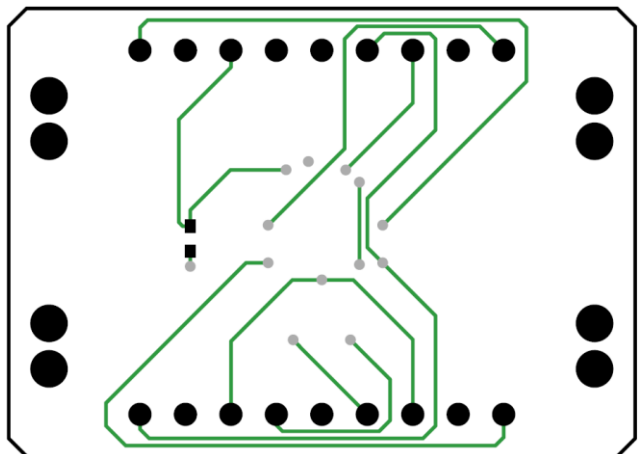

TYPICAL CHARACTERISTICS

Note: Typical Characteristics are intended to be used as reference data; they are not guaranteed.

1) Output Current vs. Efficiency with Different Input Voltages

RP604Z331x

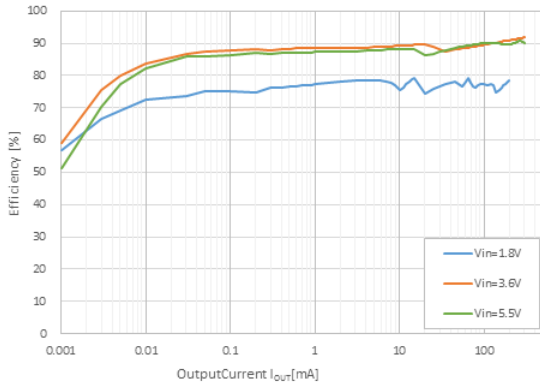

2) Output Current vs. Output Voltage with Different Input Voltages

RP604Z331x

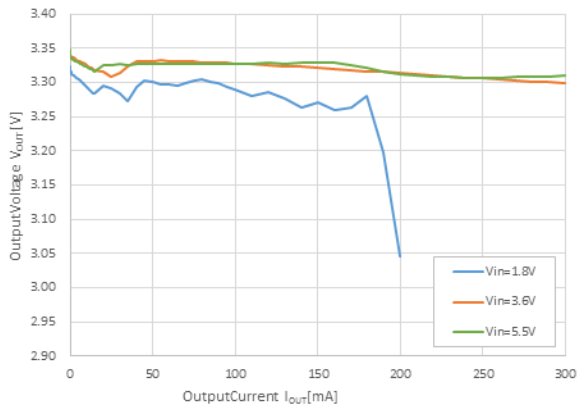

3) Temperature vs. Standby Current

RP604Z331x, $V_{IN} = 5.5 V$

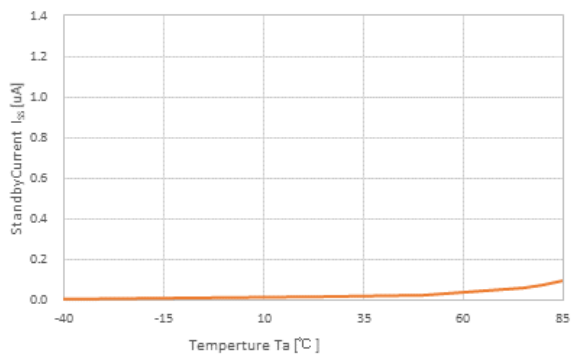

4) Input Voltage vs. Output Current

RP604Z161x, $I_{OUT} = (I_{IN} = 300 \text{ mA})$

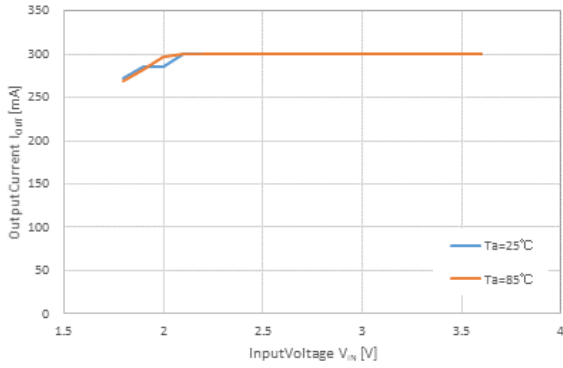

RP604Z331x, $I_{OUT} = (I_{IN} = 300 \text{ mA})$

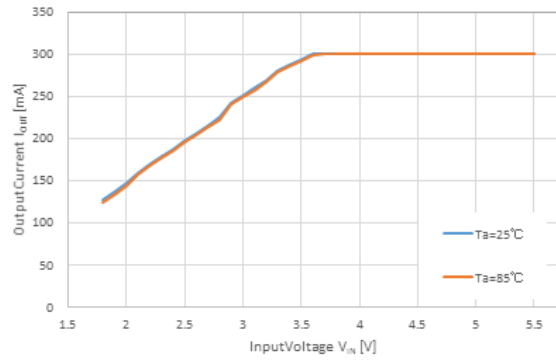

RP604Z521x, $I_{OUT} = (I_{IN} = 300 \text{ mA})$

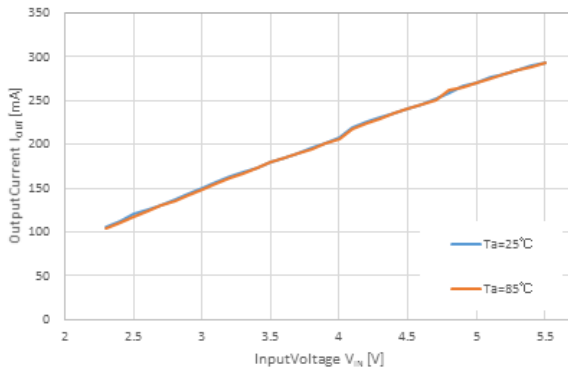

5) Output Ripple vs. Output Current

RP604Z331x

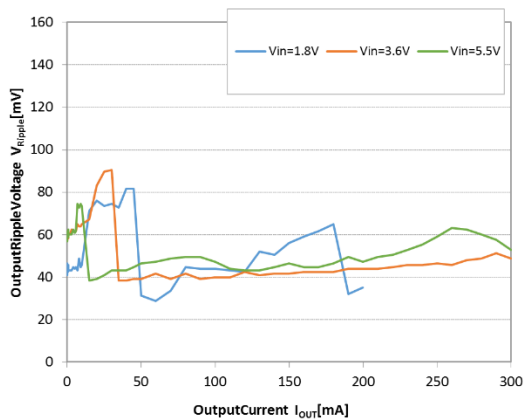

6) Input Voltage vs. Output Voltage

RP604Z331X, $I_{OUT} = 1 \text{ mA}$

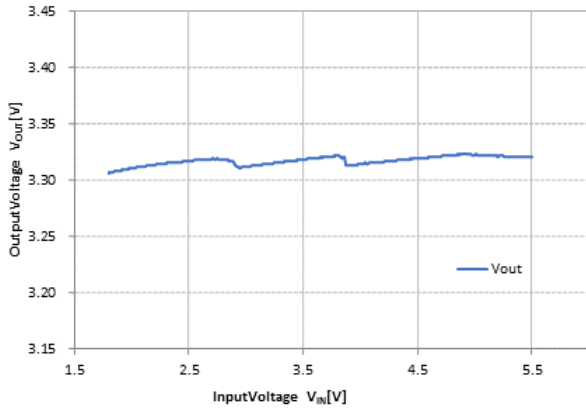

RP604Z331X, $I_{OUT} = 100 \text{ mA}$

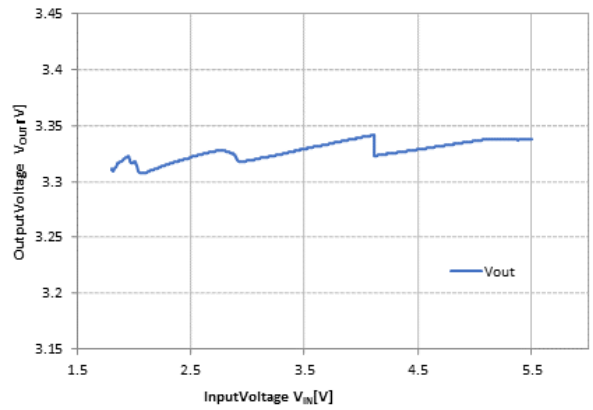

7) Starting-up/ Shutting-down Waveform with CE Pin

RP604Z331X, $I_{OUT} = 0 \text{ mA}$

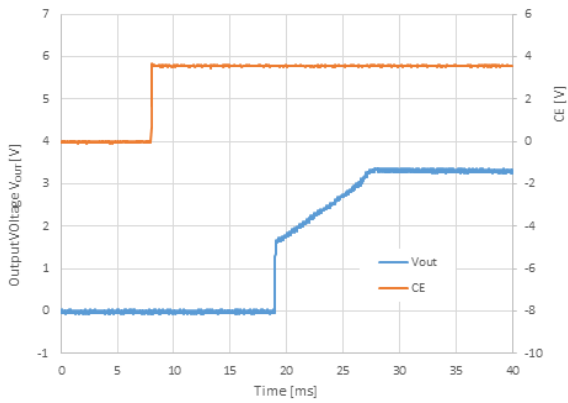

RP604Z331B, $I_{OUT} = 0 \text{ mA}$

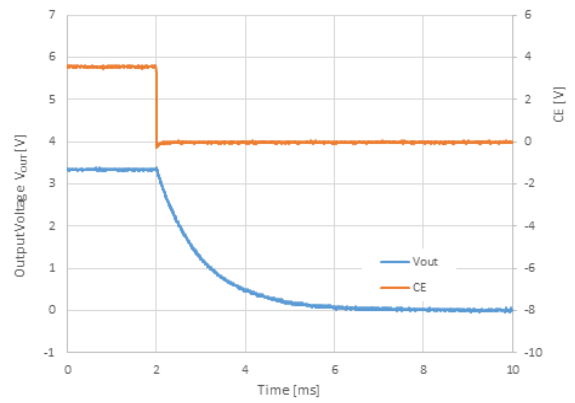

8) V_{OUT} Waveform

RP604Z331X, $V_{IN} = 3.6 \text{ V}$, $I_{OUT} = 10 \text{ mA}$

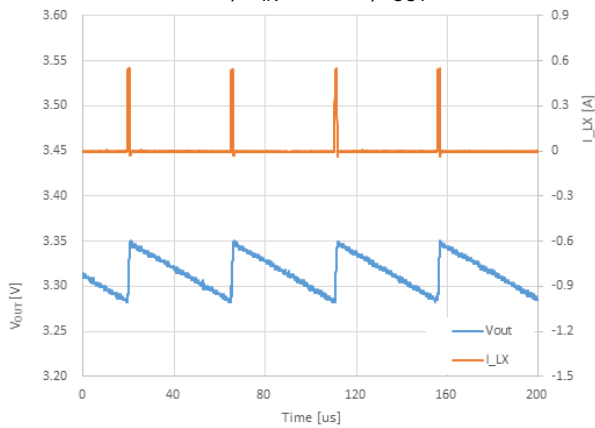

RP604Z331X, $V_{IN} = 3.6 \text{ V}$, $I_{OUT} = 100 \text{ mA}$

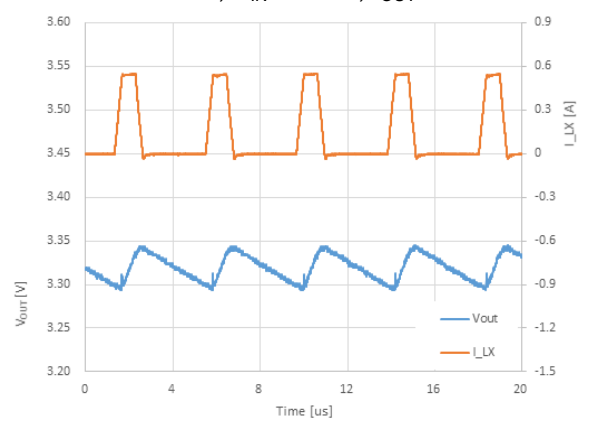

9) Load Transient Response

RP604Z331x, $V_{IN} = 3.6\text{ V}$, $I_{OUT} = 0.01\text{ mA} \leftrightarrow 100\text{ mA}$

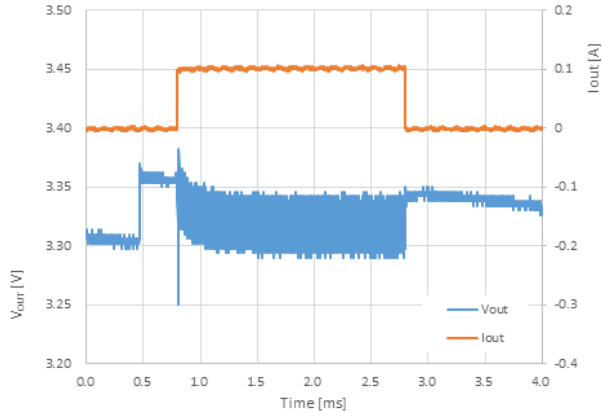

10) Input Transient Response

RP604Z331x, $V_{IN} = 2.5\text{ V} \leftrightarrow 4.5\text{ V}$, $I_{OUT} = 1\text{ mA}$

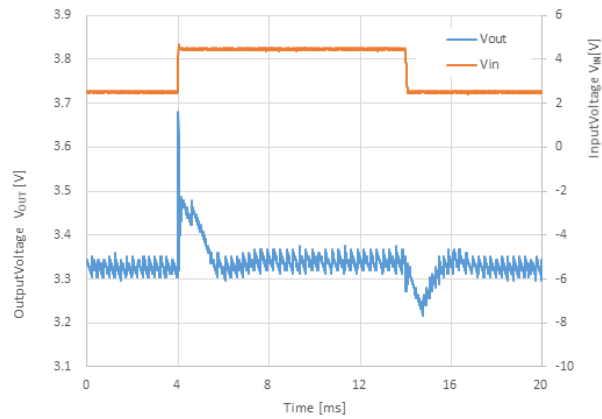

RP604Z331x, $V_{IN} = 2.5\text{ V} \leftrightarrow 4.5\text{ V}$, $I_{OUT} = 100\text{ mA}$

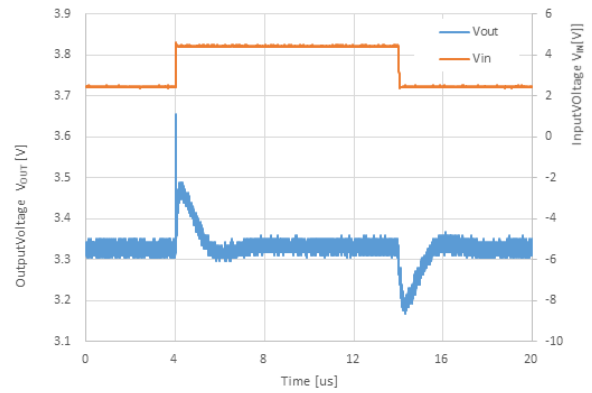

11) Temperature vs. Supply Current

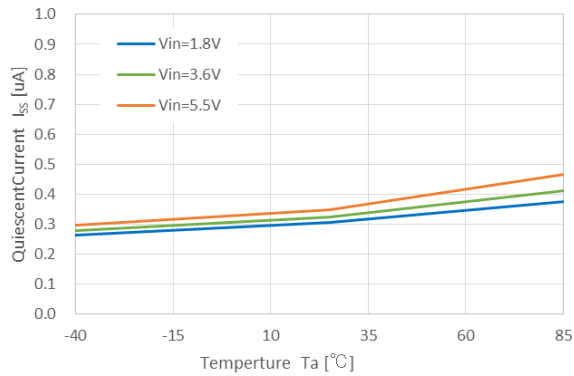

POWER DISSIPATION

WLCSP-20-P2

PD-WLCSP-20-P2-(85125)-JE-A

The power dissipation of the package is dependent on PCB material, layout, and environmental conditions. The following measurement conditions are based on JEDEC STD. 51-9.

Measurement Conditions

Item	Measurement Conditions
Environment	Mounting on Board (Wind Velocity = 0 m/s)
Board Material	Glass Cloth Epoxy Plastic (Four-Layer Board)
Board Dimensions	101.5 mm x 114.5 mm x 1.6 mm
Copper Ratio	Outer Layers (First and Fourth Layers): 60% Inner Layers (Second and Third Layers): 100%

Measurement Result

($T_a = 25^\circ\text{C}$, $T_{j\text{max}} = 125^\circ\text{C}$)

Item	Measurement Result
Power Dissipation	1490 mW
Thermal Resistance (θ_{ja})	$\theta_{ja} = 67^\circ\text{C/W}$

θ_{ja} : Junction-to-Ambient Thermal Resistance

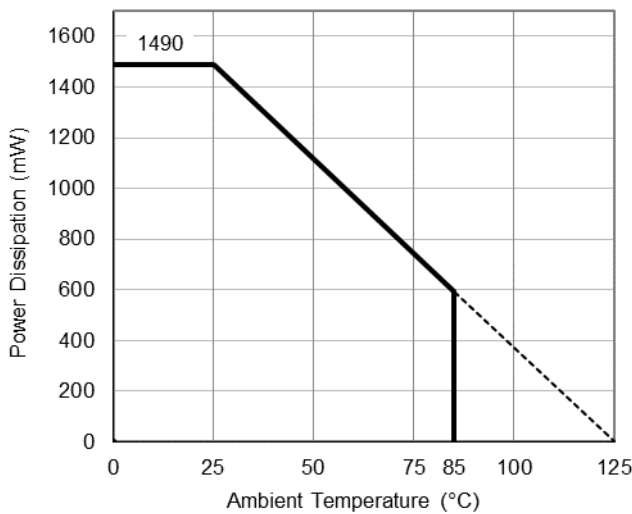

Power Dissipation vs. Ambient Temperature

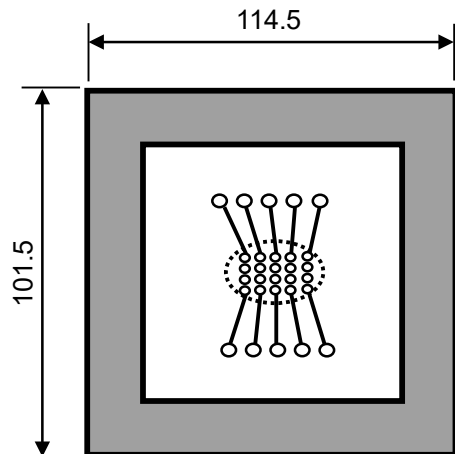

Measurement Board Pattern

PACKAGE DIMENSIONS

WLCSP-20-P2

DM-WLCSP-20-P2-JE-B

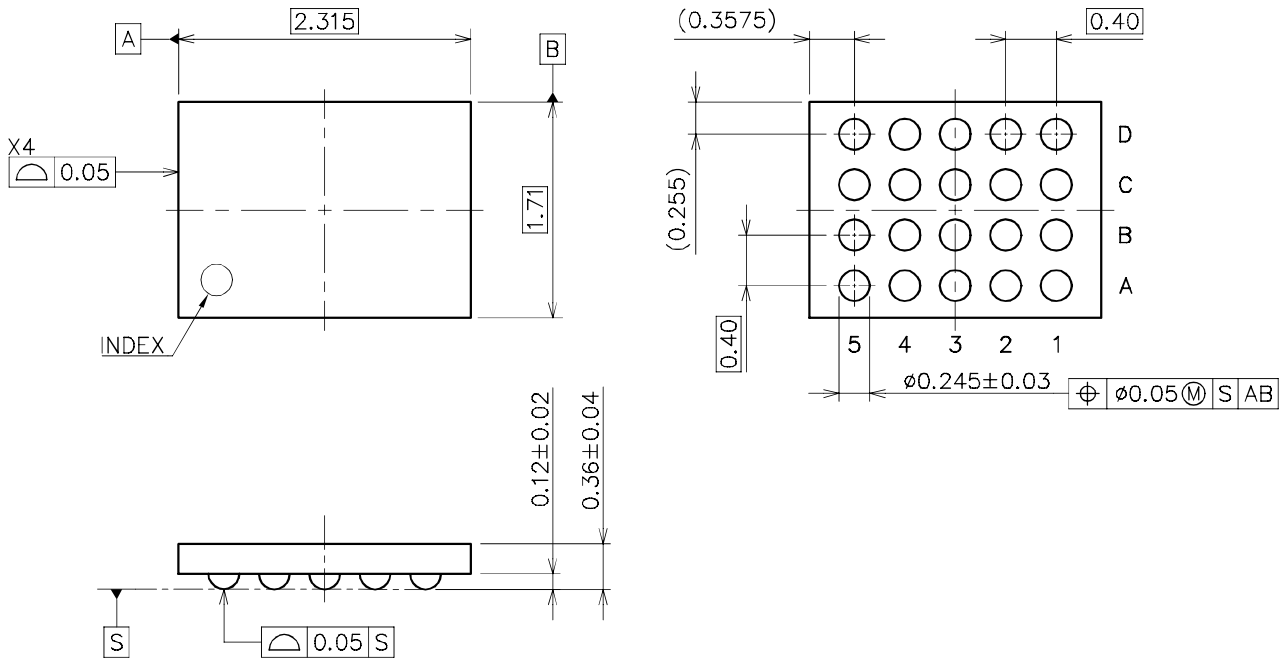

WLCSP-20-P2 Package Dimensions (Unit: mm)

PART MARKINGS

RP604Z

MK-RP604Z-JE-B

①②: Product Code ... Refer to *Part Marking List*

③④: Lot Number ... Alphanumeric Serial Number

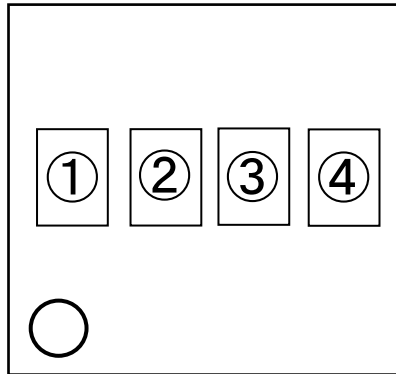

WLCSP-20-P2 Part Markings

NOTICE

There can be variation in the marking when different AOI (Automated Optical Inspection) equipment is used. In the case of recognizing the marking characteristic with AOI, please contact our sales or our distributor before attempting to use AOI.

RP604Z Part Marking List

Product Name	①②
RP604Z291A	P3
RP604Z331A	P7

Product Name	①②
RP604Z291B	V3
RP604Z331B	V7

Visual Inspection Criteria

WLCSP

VI-160823

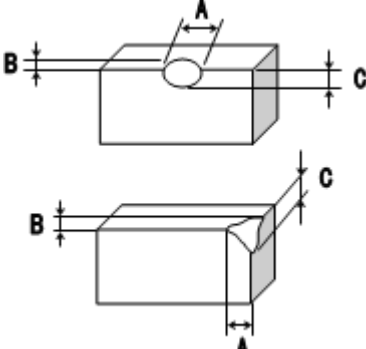
No.	Inspection Items	Inspection Criteria	Figure
1	Package chipping	$A \geq 0.2\text{mm}$ is rejected $B \geq 0.2\text{mm}$ is rejected $C \geq 0.2\text{mm}$ is rejected And, Package chipping to Si surface and to bump is rejected.	
2	Si surface chipping	$A \geq 0.2\text{mm}$ is rejected $B \geq 0.2\text{mm}$ is rejected $C \geq 0.2\text{mm}$ is rejected But, even if $A \geq 0.2\text{mm}$, $B \leq 0.1\text{mm}$ is acceptable.	
3	No bump	No bump is rejected.	
4	Marking miss	To reject incorrect marking, such as another product name marking or another lot No. marking.	
5	No marking	To reject no marking on the package.	
6	Reverse direction of marking	To reject reverse direction of marking character.	
7	Defective marking	To reject unreadable marking. (Microscope: X15/ White LED/ Viewed from vertical direction)	
8	Scratch	To reject unreadable marking character by scratch. (Microscope: X15/ White LED/ Viewed from vertical direction)	
9	Stain and Foreign material	To reject unreadable marking character by stain and foreign material. (Microscope: X15/ White LED/ Viewed from vertical direction)	

POWER DISSIPATION

DFN(PL)2730-12

PD-DFN(PL)2730-12-(85125)-JE-B

The power dissipation of the package is dependent on PCB material, layout, and environmental conditions. The following measurement conditions are based on JEDEC STD. 51.

Measurement Conditions

Item	Measurement Conditions
Environment	Mounting on Board (Wind Velocity = 0 m/s)
Board Material	Glass Cloth Epoxy Plastic (Four-Layer Board)
Board Dimensions	76.2 mm × 114.3 mm × 0.8 mm
Copper Ratio	Outer Layer (First Layer): Less than 95% of 50 mm Square Inner Layers (Second and Third Layers): Approx. 100% of 50 mm Square Outer Layer (Fourth Layer): Approx. 100% of 50 mm Square
Through-holes	φ 0.3 mm × 32 pcs

Measurement Result

(Ta = 25°C, Tjmax = 125°C)

Item	Measurement Result
Power Dissipation	3100 mW
Thermal Resistance (θ_{ja})	$\theta_{ja} = 32^{\circ}\text{C/W}$
Thermal Characterization Parameter (ψ_{jt})	$\psi_{jt} = 8^{\circ}\text{C/W}$

θ_{ja} : Junction-to-Ambient Thermal Resistance

ψ_{jt} : Junction-to-Top Thermal Characterization Parameter

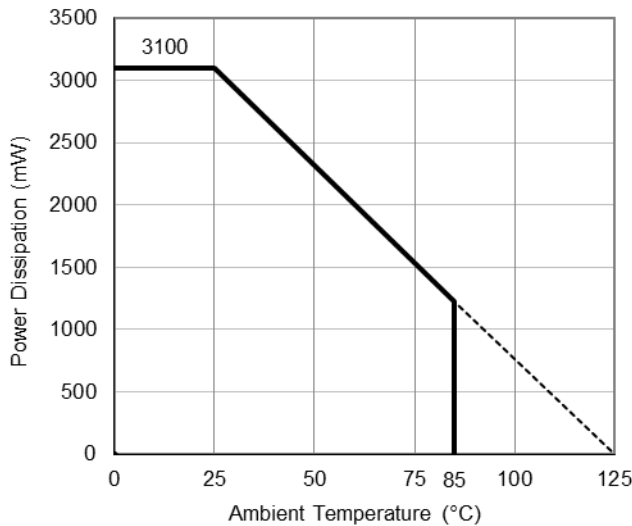

Power Dissipation vs. Ambient Temperature

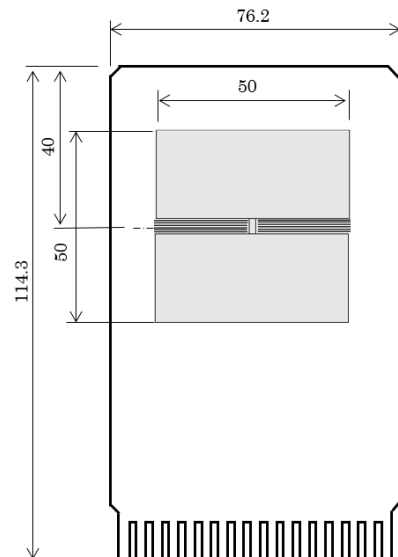

Measurement Board Pattern

RP604Zxx1x-E2-F is discontinued product.

PART MARKINGS

RP604K

MK-RP604K-JE-B

①②③④: Product Code ··· Refer to *Part Marking List*

⑤⑥: Lot Number ··· Alphanumeric Serial Number

12 11 10 9 8 7

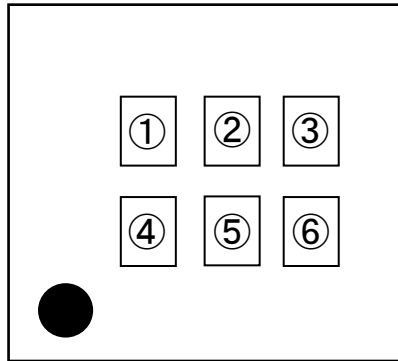

1 2 3 4 5 6

DFN(PL)2730-12 Part Markings

NOTICE

There can be variation in the marking when different AOI (Automated Optical Inspection) equipment is used. In the case of recognizing the marking characteristic with AOI, please contact our sales or our distributor before attempting to use AOI.

PART MARKINGS

RP604K

MK-RP604K-JE-B

RP604K Part Marking List

Product Name	①②③④	Product Name	①②③④
RP604K161A	FR00	RP604K161B	FS00
RP604K171A	FR01	RP604K171B	FS01
RP604K181A	FR02	RP604K181B	FS02
RP604K191A	FR03	RP604K191B	FS03
RP604K201A	FR04	RP604K201B	FS04
RP604K211A	FR05	RP604K211B	FS05
RP604K221A	FR06	RP604K221B	FS06
RP604K231A	FR07	RP604K231B	FS07
RP604K241A	FR08	RP604K241B	FS08
RP604K251A	FR09	RP604K251B	FS09
RP604K261A	FR10	RP604K261B	FS10
RP604K271A	FR11	RP604K271B	FS11
RP604K281A	FR12	RP604K281B	FS12
RP604K291A	FR13	RP604K291B	FS13
RP604K301A	FR14	RP604K301B	FS14
RP604K311A	FR15	RP604K311B	FS15
RP604K321A	FR16	RP604K321B	FS16
RP604K331A	FR17	RP604K331B	FS17
RP604K341A	FR18	RP604K341B	FS18
RP604K351A	FR19	RP604K351B	FS19
RP604K361A	FR20	RP604K361B	FS20
RP604K371A	FR21	RP604K371B	FS21
RP604K381A	FR22	RP604K381B	FS22
RP604K391A	FR23	RP604K391B	FS23
RP604K401A	FR24	RP604K401B	FS24
RP604K411A	FR25	RP604K411B	FS25
RP604K421A	FR26	RP604K421B	FS26
RP604K431A	FR27	RP604K431B	FS27
RP604K441A	FR28	RP604K441B	FS28
RP604K451A	FR29	RP604K451B	FS29
RP604K461A	FR30	RP604K461B	FS30
RP604K471A	FR31	RP604K471B	FS31
RP604K481A	FR32	RP604K481B	FS32
RP604K491A	FR33	RP604K491B	FS33
RP604K501A	FR34	RP604K501B	FS34
RP604K511A	FR35	RP604K511B	FS35
RP604K521A	FR36	RP604K521B	FS36

1. The products and the product specifications described in this document are subject to change or discontinuation of production without notice for reasons such as improvement. Therefore, before deciding to use the products, please refer to our sales representatives for the latest information thereon.
2. The materials in this document may not be copied or otherwise reproduced in whole or in part without the prior written consent of us.
3. This product and any technical information relating thereto are subject to complementary export controls (so-called KNOW controls) under the Foreign Exchange and Foreign Trade Law, and related politics ministerial ordinance of the law. (Note that the complementary export controls are inapplicable to any application-specific products, except rockets and pilotless aircraft, that are insusceptible to design or program changes.) Accordingly, when exporting or carrying abroad this product, follow the Foreign Exchange and Foreign Trade Control Law and its related regulations with respect to the complementary export controls.
4. The technical information described in this document shows typical characteristics and example application circuits for the products. The release of such information is not to be construed as a warranty of or a grant of license under our or any third party's intellectual property rights or any other rights.
5. The products listed in this document are intended and designed for use as general electronic components in standard applications (office equipment, telecommunication equipment, measuring instruments, consumer electronic products, amusement equipment etc.). Those customers intending to use a product in an application requiring extreme quality and reliability, for example, in a highly specific application where the failure or misoperation of the product could result in human injury or death should first contact us.
 - Aerospace Equipment
 - Equipment Used in the Deep Sea
 - Power Generator Control Equipment (nuclear, steam, hydraulic, etc.)
 - Life Maintenance Medical Equipment
 - Fire Alarms / Intruder Detectors
 - Vehicle Control Equipment (automotive, airplane, railroad, ship, etc.)
 - Various Safety Devices
 - Traffic control system
 - Combustion equipment

In case your company desires to use this product for any applications other than general electronic equipment mentioned above, make sure to contact our company in advance. Note that the important requirements mentioned in this section are not applicable to cases where operation requirements such as application conditions are confirmed by our company in writing after consultation with your company.

6. We are making our continuous effort to improve the quality and reliability of our products, but semiconductor products are likely to fail with certain probability. In order to prevent any injury to persons or damages to property resulting from such failure, customers should be careful enough to incorporate safety measures in their design, such as redundancy feature, fire containment feature and fail-safe feature. We do not assume any liability or responsibility for any loss or damage arising from misuse or inappropriate use of the products.
7. The products have been designed and tested to function within controlled environmental conditions. Do not use products under conditions that deviate from methods or applications specified in this datasheet. Failure to employ the products in the proper applications can lead to deterioration, destruction or failure of the products. We shall not be responsible for any bodily injury, fires or accident, property damage or any consequential damages resulting from misuse or misapplication of the products.
8. **Quality Warranty**
 - 8-1. **Quality Warranty Period**

In the case of a product purchased through an authorized distributor or directly from us, the warranty period for this product shall be one (1) year after delivery to your company. For defective products that occurred during this period, we will take the quality warranty measures described in section 8-2. However, if there is an agreement on the warranty period in the basic transaction agreement, quality assurance agreement, delivery specifications, etc., it shall be followed.
 - 8-2. **Quality Warranty Remedies**

When it has been proved defective due to manufacturing factors as a result of defect analysis by us, we will either deliver a substitute for the defective product or refund the purchase price of the defective product.

Note that such delivery or refund is sole and exclusive remedies to your company for the defective product.
 - 8-3. **Remedies after Quality Warranty Period**

With respect to any defect of this product found after the quality warranty period, the defect will be analyzed by us. On the basis of the defect analysis results, the scope and amounts of damage shall be determined by mutual agreement of both parties. Then we will deal with upper limit in Section 8-2. This provision is not intended to limit any legal rights of your company.
9. Anti-radiation design is not implemented in the products described in this document.
10. The X-ray exposure can influence functions and characteristics of the products. Confirm the product functions and characteristics in the evaluation stage.
11. WLCSP products should be used in light shielded environments. The light exposure can influence functions and characteristics of the products under operation or storage.
12. Warning for handling Gallium and Arsenic (GaAs) products (Applying to GaAs MMIC, Photo Reflector). These products use Gallium (Ga) and Arsenic (As) which are specified as poisonous chemicals by law. For the prevention of a hazard, do not burn, destroy, or process chemically to make them as gas or power. When the product is disposed of, please follow the related regulation and do not mix this with general industrial waste or household waste.
13. Please contact our sales representatives should you have any questions or comments concerning the products or the technical information.



Nisshinbo Micro Devices Inc.

Official website

<https://www.nisshinbo-microdevices.co.jp/en/>

Purchase information

<https://www.nisshinbo-microdevices.co.jp/en/buy/>