

100 mA Ultra-Low Supply Current Voltage Regulator

No. EA-399-251006

OVERVIEW

RP118x is a voltage regulator featuring 0.2 μA ultra-low supply current. This device is ideal for a wearable equipment and IoT which require a long service life and a miniaturization of a battery.

KEY BENEFITS

- Achieves a low supply current (0.2 μA) and contributes to a long-life and a miniaturized battery.
- Provides a small package to achieve the smallest possible footprint solution on boards where area is limited.

KEY SPECIFICATIONS

- Supply Current Typ. 0.2 μA
- Standby Current Typ. 0.002 μA
- Output Voltage Accuracy $\pm 0.8\%$
- Input Voltage Range (Maximum Rating) 1.7 V to 5.5 V (6.5 V)
- Output Voltage Range 1.2 V to 3.6 V (0.1 V step)
- Built-in Fold Back Protection Circuit Typ. 50 mA (Current at short mode)
- Ceramic capacitors recommended to be used 1.0 μF or more
- Dropout Voltage Typ. 0.1 V ($I_{\text{OUT}} = 100 \text{ mA}$, $V_{\text{SET}} = 2.8 \text{ V}$)
- Operating mode Automatic mode (Automatically shifts between fast response mode and low power mode)

TYPICAL APPLICATIONS

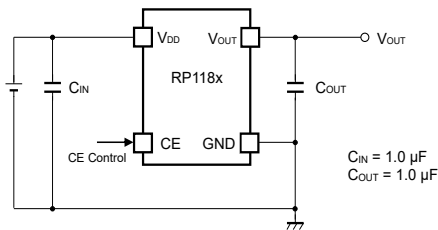

PACKAGE

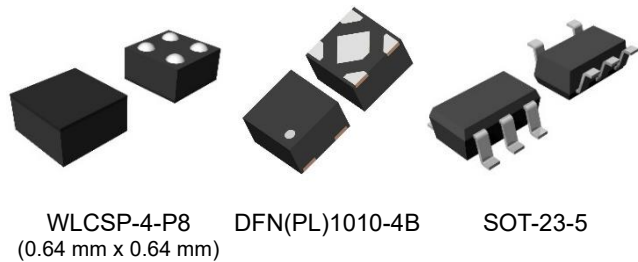

SELECTION GUIDE

Product Name	Package
RP118Zxx1*-TR-F	WLCSP-4-P8
RP118Kxx1*-TR	DFN(PL)1010-4B
RP118Nxx1*-TR-FE	SOT-23-5

*: Select auto-discharge function

Version	CE pin	Auto-discharge
B	Active-high	Disable
D	Active-high	Auto-discharge

xx: Set output voltage (V_{SET}) is selectable from 1.2 V to 3.6 V in 0.1 V step.

APPLICATIONS

- Wearable equipment such as SmartWatch, SmartBand, and health monitoring
- Li-ion battery-used equipment and coin cell-used equipment
- Low power RF such as *Bluetooth*® Low Energy, Zigbee, WiSun, ANT
- Low power CPU, memory, sensor devices, and energy harvesting

SELECTION GUIDE

The set output voltage, the auto-discharge function, and the package for the ICs are user-selectable options.

Selection Guide

Product Name	Package	Quantity per Reel	Pb Free	Halogen Free
RP118Zxx1*-TR-F	WLCSP-4-P8	5,000 pcs	Yes	Yes
RP118Kxx1*-TR	DFN(PL)1010-4B	10,000 pcs	Yes	Yes
RP118Nxx1*-TR-FE	SOT-23-5	3,000 pcs	Yes	Yes

xx: Set output voltage (V_{SET}) is selectable from 1.2 V (12) to 3.6 V (36) in 0.1 V step.

The voltage in 0.05 V step is shown as follows.

1.85 V: RP118x181*5

*: Select auto-discharge function

Version	CE pin	Auto-discharge
B	Active-high	Disable
D	Active-high	Auto-discharge

BLOCK DIAGRAM

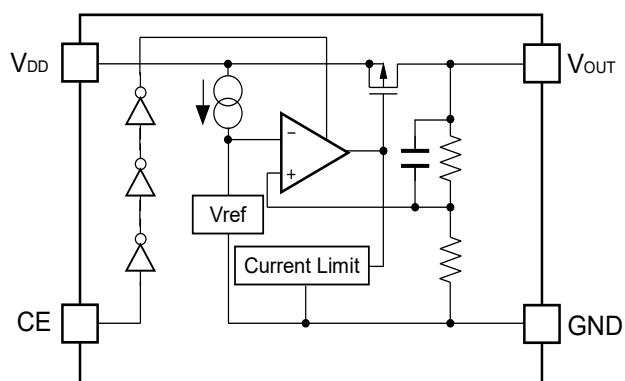

RP118xxx1B Block Diagram

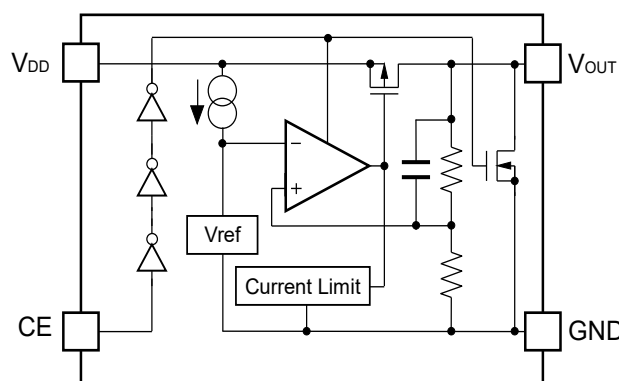

RP118xxx1D Block Diagram

PIN DESCRIPTION

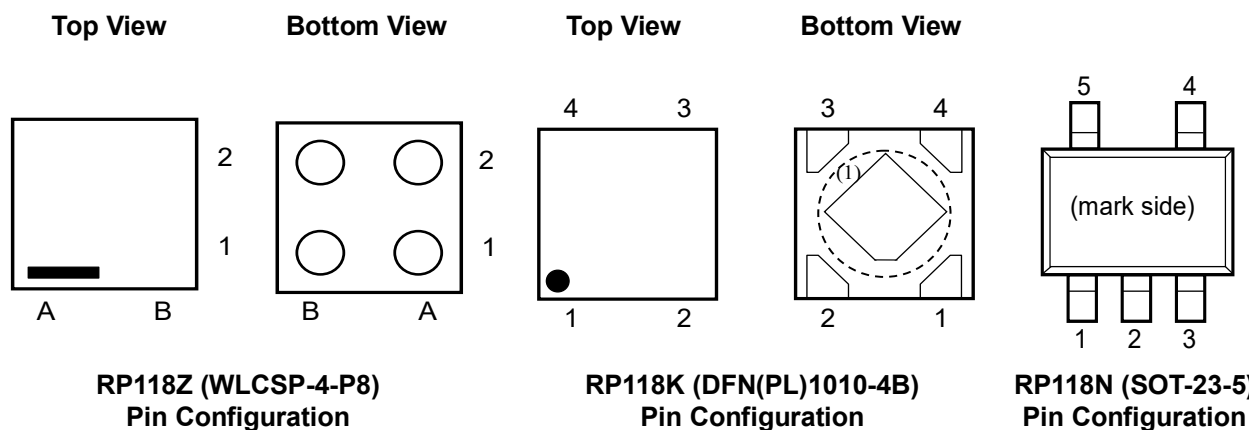

WLCSP-4-P8 Pin Description

Pin No	Symbol	Pin Description
A1	VDD	Input Pin
A2	VOUT	Output Pin
B1	CE	Chip Enable Pin (Active-high)
B2	GND	Ground Pin

DFN(PL)1010-4B Pin Description

Pin No	Symbol	Description
1	VOUT	Output Pin
2	GND	Ground Pin
3	CE	Chip Enable Pin (Active-high)
4	VDD	Input Pin

SOT-23-5 Pin Description

Pin No	Symbol	Pin Description
1	VDD	Input Pin
2	GND	Ground Pin
3	CE	Chip Enable Pin (Active-high)
4	NC	No connection
5	VOUT	Output Pin

⁽¹⁾ The tab on the bottom of the package enhances thermal performance and is electrically connected to GND (substrate level). It is recommended that the tab be connected to the ground plane on the board, or otherwise be left floating.

ABSOLUTE MAXIMUM RATINGS

Absolute Maximum Ratings

Symbol	Item	Rating	Unit	
V_{IN}	Input Voltage	-0.3 to 6.5	V	
V_{CE}	CE Pin Input Voltage	-0.3 to 6.5	V	
V_{OUT}	VOUT Pin Voltage	-0.3 to $V_{IN} + 0.3$	V	
I_{OUT}	Output Current	130	mA	
P_D	Power Dissipation ⁽¹⁾	WLCSP-4-P8, JEDEC STD. 51-9 Test Land Pattern	470	mW
		DFN(PL)1010-4B, JEDEC STD. 51-7 Test Land Pattern	510	mW
		SOT-23-5, JEDEC STD. 51-7 Test Land Pattern	660	mW
T_j	Junction Temperature Range	-40 to 125	°C	
T_{stg}	Storage Temperature Range	-55 to 125	°C	

ABSOLUTE MAXIMUM RATINGS

Electronic and mechanical stress momentarily exceeded absolute maximum ratings may cause the permanent damages and may degrade the life time and safety for both device and system using the device in the field. The functional operation at or over these absolute maximum ratings is not assured.

RECOMMENDED OPERATING CONDITIONS

Recommended Operating Conditions

Symbol	Item	Rating	Unit
V_{IN}	Input Voltage	1.7 to 5.5	V
T_a	Operating Temperature Range	-40 to 85	°C

RECOMMENDED OPERATING CONDITIONS

All of electronic equipment should be designed that the mounted semiconductor devices operate within the recommended operating conditions. The semiconductor devices cannot operate normally over the recommended operating conditions, even if when they are used over such conditions by momentary electronic noise or surge. And the semiconductor devices may receive serious damage when they continue to operate over the recommended operating conditions.

⁽¹⁾ Refer to *POWER DISSIPATION* for detailed information.

ELECTRICAL CHARACTERISTICS

$V_{IN} = V_{SET} + 1.0\text{ V}$, $I_{OUT} = 1.5\text{ mA}$, $C_{IN} = C_{OUT} = 1.0\text{ }\mu\text{F}$, unless otherwise noted.

The specifications surrounded by are guaranteed by design engineering at $-40^{\circ}\text{C} \leq T_a \leq 85^{\circ}\text{C}$.

RP118xxx1B/D Electrical Characteristics

($T_a = 25^{\circ}\text{C}$)

Symbol	Parameter	Test Conditions/Comments	Min.	Typ.	Max.	Unit	
V_{OUT}	Output Voltage (Fast Response Mode)	$T_a = 25^{\circ}\text{C}$	$V_{SET} > 2.0\text{ V}$	x 0.992		x 1.008	V
			$V_{SET} \leq 2.0\text{ V}$	-16		16	mV
		$-40^{\circ}\text{C} \leq T_a \leq 85^{\circ}\text{C}$	$V_{SET} > 2.0\text{ V}$	x 0.987		x 1.013	V
			$V_{SET} \leq 2.0\text{ V}$	-26		26	mV
I_{OUT}	Output Current		100			mA	
$\frac{\Delta V_{OUT}}{\Delta I_{OUT}}$	Load Regulation	$1\text{ }\mu\text{A} \leq I_{OUT} \leq 1.5\text{ mA}$	$V_{SET} > 2.0\text{ V}$	x 0.99		x 1.01	V
			$V_{SET} \leq 2.0\text{ V}$	-20		20	mV
		$1.5\text{ mA} \leq I_{OUT} \leq 100\text{ mA}$	-40	2	40	mV	
V_{DIF}	Dropout Voltage	$I_{OUT} = 100\text{ mA}$	Refer to <i>PRODUCT-SPECIFIC ELECTRICAL CHARACTERISTICS</i>				
I_{SS}	Supply Current	$V_{CE} = V_{IN}$, $I_{OUT} = 0\text{ mA}$		0.2	0.42	μA	
					0.5	μA	
$I_{STANDBY}$	Standby Current	$V_{CE} = 0\text{ V}$		0.002	0.055	μA	
I_{OUTH}	Fast Response Mode switch-over current	$I_{OUT} = \text{Light load to Heavy load}$ $V_{IN} = 5.0\text{ V}$			1.5	mA	
I_{OUTL}	Low Power Mode switch-over current	$I_{OUT} = \text{Heavy load to Light load}$ $V_{IN} = 5.0\text{ V}$	0.08			mA	
$\frac{\Delta V_{OUT}}{\Delta V_{IN}}$	Line Regulation	$V_{SET} + 0.5\text{ V} \leq V_{IN} \leq 5.5\text{ V}$		0.02	0.2	%/V	
I_{SC}	Short-circuit Current Limit	$V_{OUT} = 0\text{ V}$		50		mA	
V_{CEH}	CE Pin Input Voltage, high		1.0			V	
V_{CEL}	CE Pin Input Voltage, low				0.4	V	
R_{LOW}	LOW Output NMOS On-state Resistance (RP118xxx1D only)	$V_{IN} = 4.0\text{ V}$, $V_{CE} = 0\text{ V}$		50		Ω	

All test items listed under Electrical Characteristics are done under the pulse load condition ($T_j \approx T_a = 25^{\circ}\text{C}$).

The specifications surrounded by are guaranteed by design engineering at $-40^{\circ}\text{C} \leq T_a \leq 85^{\circ}\text{C}$.

Product-specific Electrical Characteristics

Product Name	V _{OUT} [V]						V _{DIF} [V]	
	T _a = 25°C			-40°C ≤ T _a ≤ 85°C			Typ.	Max.
	Min.	Typ.	Max.	Min.	Typ.	Max.		
RP118x121x	1.184	1.200	1.216	1.174	1.200	1.226	0.640	0.975
RP118x121x5	1.234	1.250	1.266	1.224	1.250	1.276		
RP118x131x	1.284	1.300	1.316	1.274	1.300	1.326	0.560	0.890
RP118x141x	1.384	1.400	1.416	1.374	1.400	1.426	0.490	0.770
RP118x151x	1.484	1.500	1.516	1.474	1.500	1.526	0.410	0.660
RP118x161x	1.584	1.600	1.616	1.574	1.600	1.626	0.340	0.560
RP118x171x	1.684	1.700	1.716	1.674	1.700	1.726	0.280	0.435
RP118x181x	1.784	1.800	1.816	1.774	1.800	1.826	0.230	0.380
RP118x181x5	1.834	1.850	1.866	1.824	1.850	1.876		
RP118x191x	1.884	1.900	1.916	1.874	1.900	1.926	0.200	0.320
RP118x201x	1.984	2.000	2.016	1.974	2.000	2.026	0.150	0.285
RP118x211x	2.084	2.100	2.116	2.073	2.100	2.127		
RP118x221x	2.183	2.200	2.217	2.172	2.200	2.228	0.130	0.230
RP118x231x	2.282	2.300	2.318	2.271	2.300	2.329		
RP118x241x	2.381	2.400	2.419	2.369	2.400	2.431	0.110	0.180
RP118x251x	2.480	2.500	2.520	2.468	2.500	2.532		
RP118x261x	2.580	2.600	2.620	2.567	2.600	2.633	0.100	0.160
RP118x271x	2.679	2.700	2.721	2.665	2.700	2.735		
RP118x281x	2.778	2.800	2.822	2.764	2.800	2.836	0.100	0.160
RP118x291x	2.877	2.900	2.923	2.863	2.900	2.937		
RP118x301x	2.976	3.000	3.024	2.961	3.000	3.039	0.090	0.145
RP118x311x	3.076	3.100	3.124	3.060	3.100	3.140		
RP118x321x	3.175	3.200	3.225	3.159	3.200	3.241	0.090	0.145
RP118x331x	3.274	3.300	3.326	3.258	3.300	3.342		
RP118x341x	3.373	3.400	3.427	3.356	3.400	3.444	0.090	0.145
RP118x351x	3.472	3.500	3.528	3.455	3.500	3.545		
RP118x361x	3.572	3.600	3.628	3.554	3.600	3.646	0.090	0.145

APPLICATION INFORMATION

Typical Application

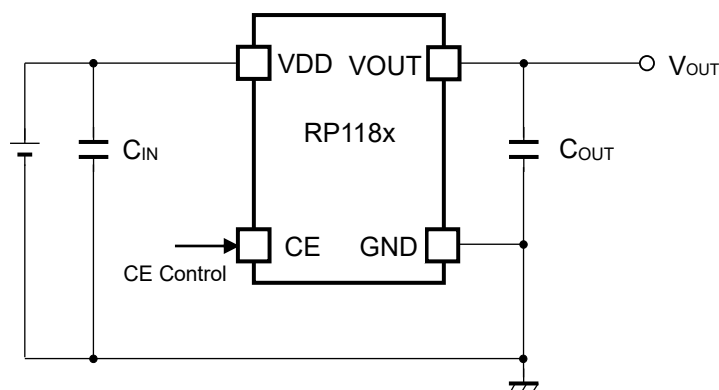

RP118x Typical Application

External Components

Symbol	Description
C_{IN}	Ceramic Capacitor 1.0 μ F MURATA GRM155R61A105KE15
C_{OUT}	Ceramic Capacitor 1.0 μ F MURATA GRM155R61A105KE15

Technical Notes on the External Components

- In this device, phase compensation is provided to secure stable operation even when the load current is varied. For this purpose, use a 1.0 μ F or more output capacitor (C_{OUT}). In case of using a tantalum type capacitor with a large ESR (Equivalent Series Resistance), the output might become unstable. Evaluate your circuit including consideration of frequency characteristics.
- Ensure the VDD and GND lines are sufficiently robust. If their impedances are too high, noise pickup or unstable operation may result. Connect a 1.0 μ F or more input capacitor (C_{IN}) between the VDD and GND pins with shortest-distance wiring. Also, connect an output capacitor (C_{OUT}) between the VOUT and GND pins with shortest-distance wiring.

TECHNICAL NOTES

- When an intermediate voltage other than V_{IN} or GND is input to the CE pin, a supply current may be increased with a through current of a logic circuit in the IC. The CE pin is neither pulled up nor pulled down, therefore an operation is not stable at open.

TYPICAL CHARACTERISTICS

Typical Characteristics are intended to be used as reference data; they are not guaranteed.

1) Output Voltage vs. Temperature (C_{IN} = Ceramic 1.0 μ F, C_{OUT} = Ceramic 1.0 μ F)

RP118x121x, V_{IN} = 2.2 V, I_{OUT} = 1 mA

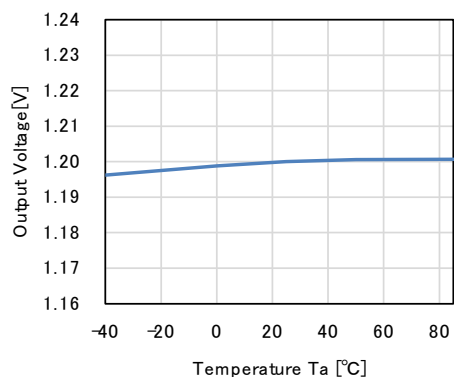

RP118x181x, V_{IN} = 2.8 V, I_{OUT} = 1 mA

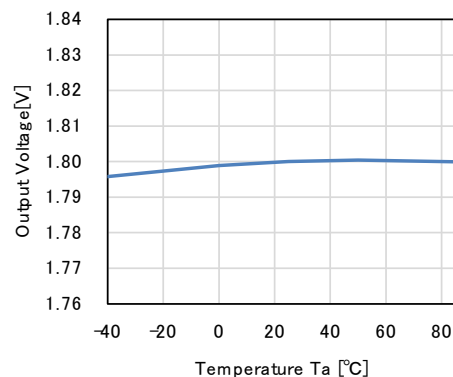

RP118x281x, V_{IN} = 3.8 V, I_{OUT} = 1 mA

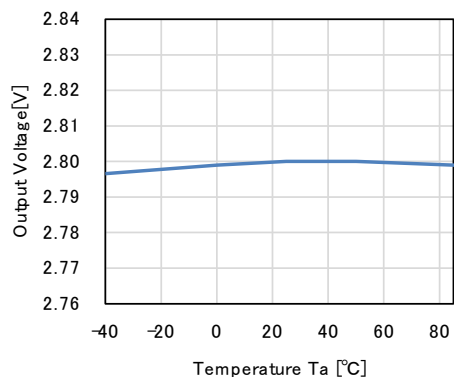

RP118x361x, V_{IN} = 4.6 V, I_{OUT} = 1 mA

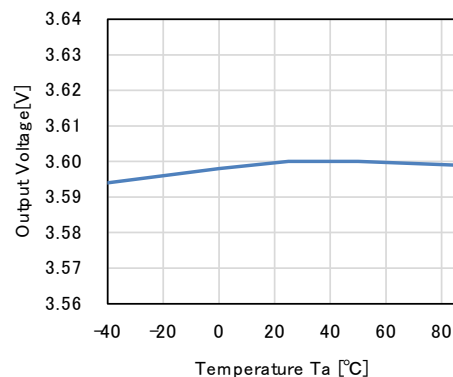

2) Supply Current vs. Temperature (C_{IN} = Ceramic 1.0 μ F, C_{OUT} = Ceramic 1.0 μ F)

RP118x121x, V_{IN} = 2.2 V

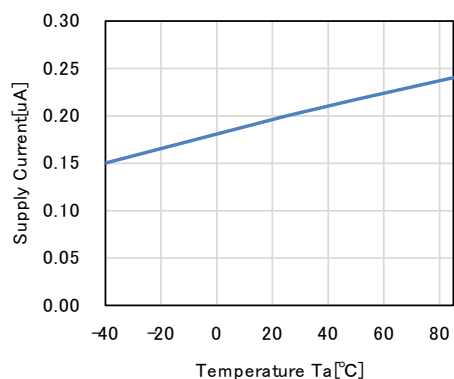

RP118x181x, V_{IN} = 2.8 V

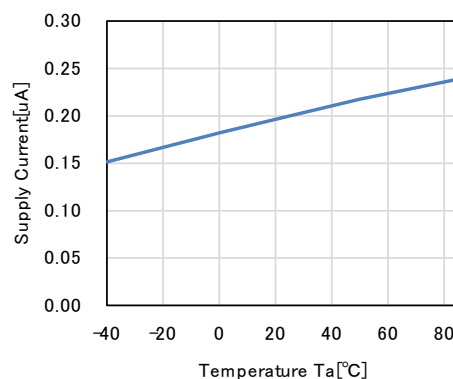

* Typical characteristics at I_{OUT} = 1 mA are evaluated in a fast response mode.

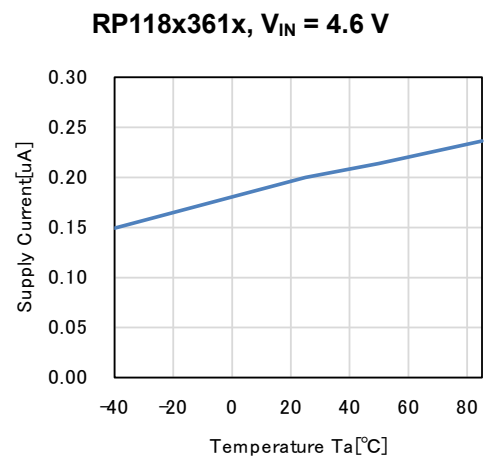
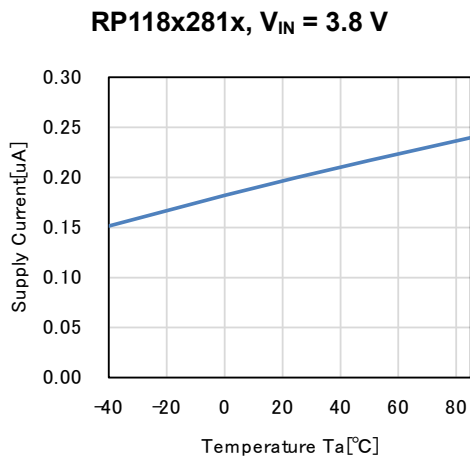

3) Dropout Voltage vs. Temperature ($C_{IN} = \text{Ceramic } 1.0\ \mu\text{F}$, $C_{OUT} = \text{Ceramic } 1.0\ \mu\text{F}$)

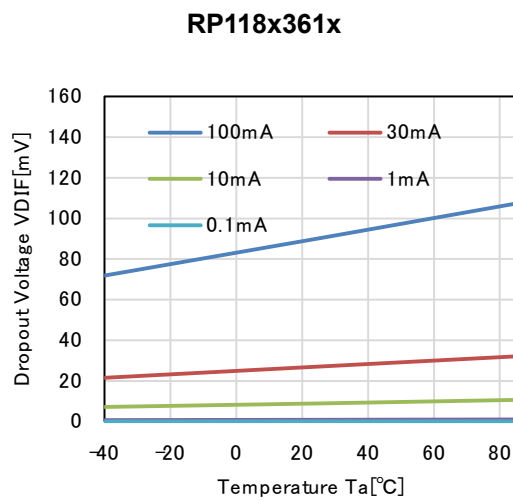
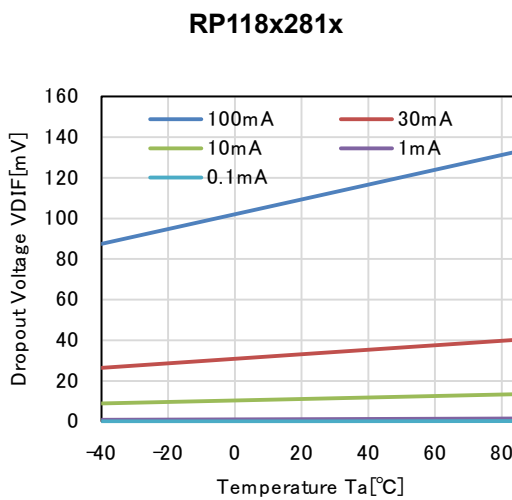
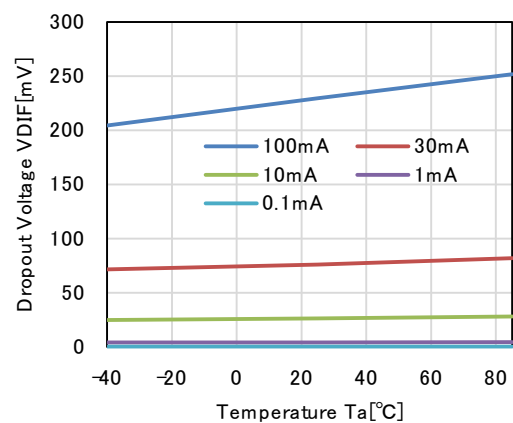
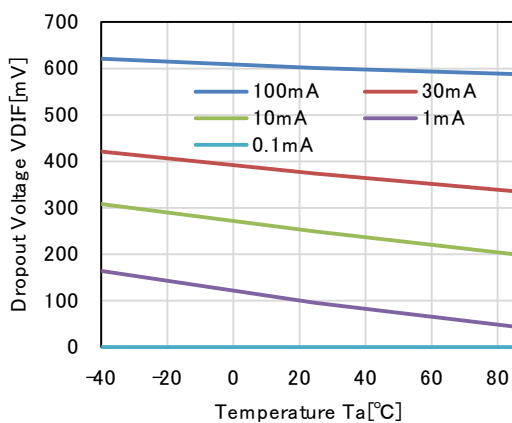

* Typical characteristics at $I_{OUT} = 1\text{ mA}$ are evaluated in a fast response mode.

4) Dropout Voltage vs Output Current ($C_{IN} = \text{Ceramic } 1.0 \mu\text{F}$, $C_{OUT} = \text{Ceramic } 1.0 \mu\text{F}$)
RP118x121x **RP118x181x**

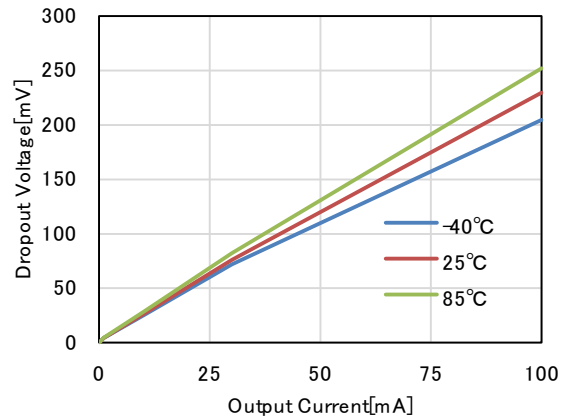
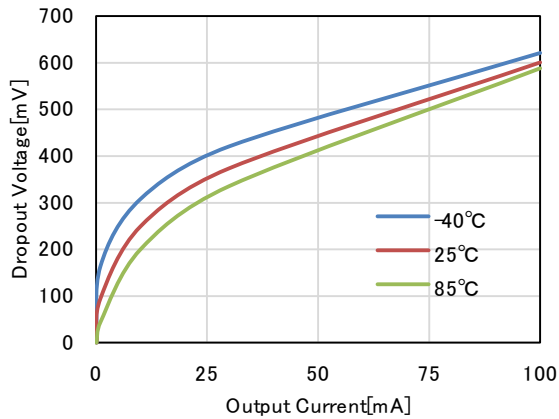

RP118x281x

RP118x361x

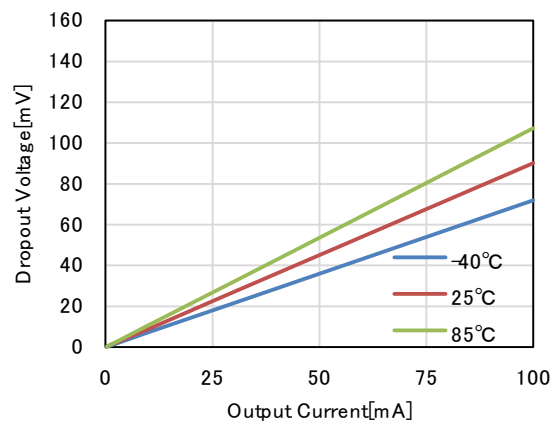
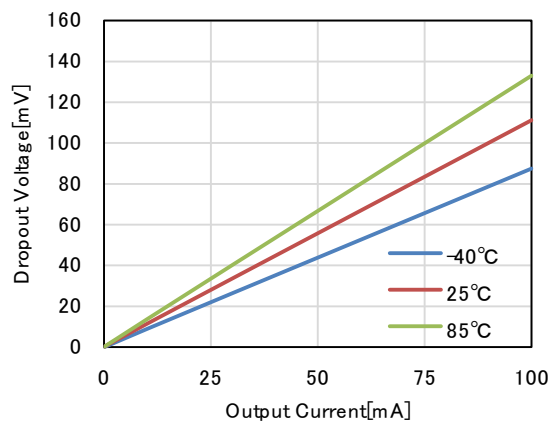

5) Dropout Voltage vs Set Output Voltage ($C_{IN} = \text{Ceramic } 1.0 \mu\text{F}$, $C_{OUT} = \text{Ceramic } 1.0 \mu\text{F}$, $T_a = 25^\circ\text{C}$)

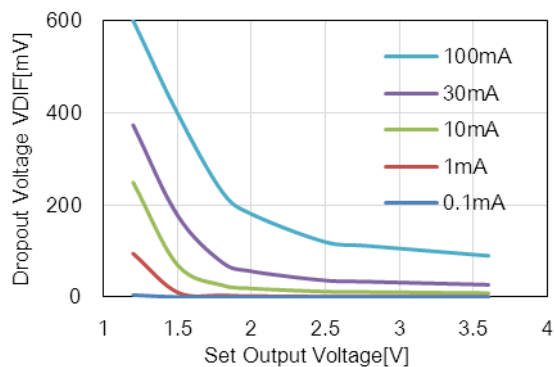

* Typical characteristics at $I_{OUT} = 1 \text{ mA}$ are evaluated in a fast response mode.

6) Output Voltage vs. Output Current (C_{IN} = Ceramic 1.0 μ F, C_{OUT} = Ceramic 1.0 μ F, T_a = 25°C)

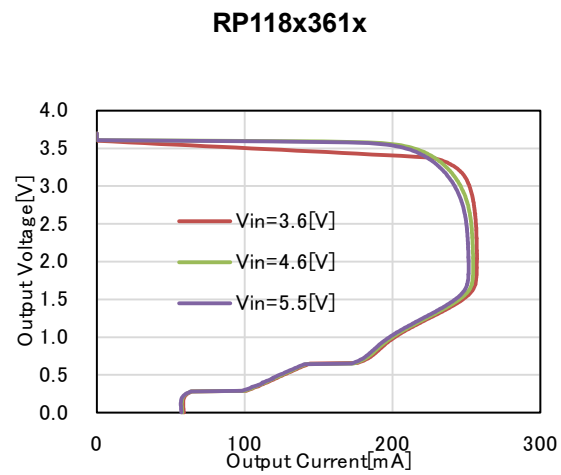
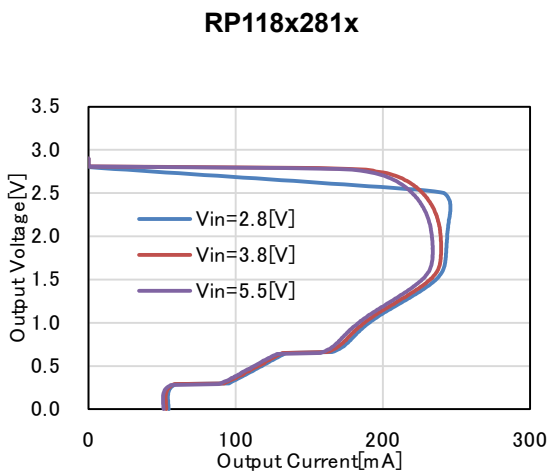
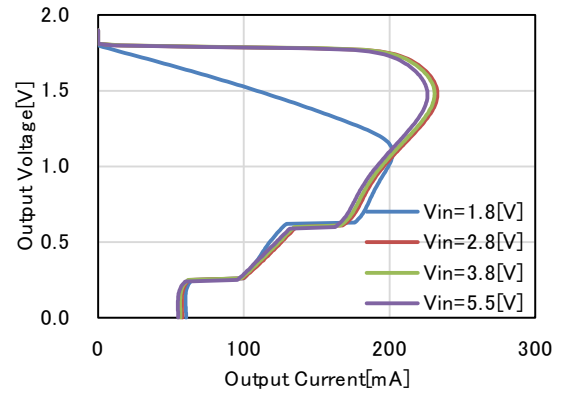
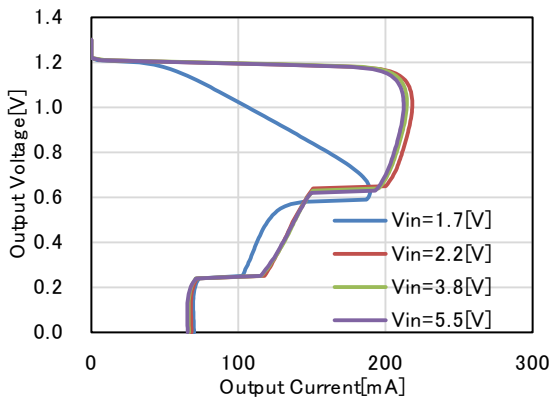

7) Output Voltage vs. Input Voltage (C_{IN} = Ceramic 1.0 μ F, C_{OUT} = Ceramic 1.0 μ F, T_a = 25°C)

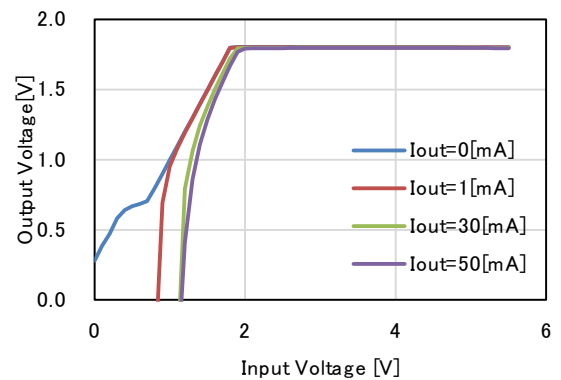
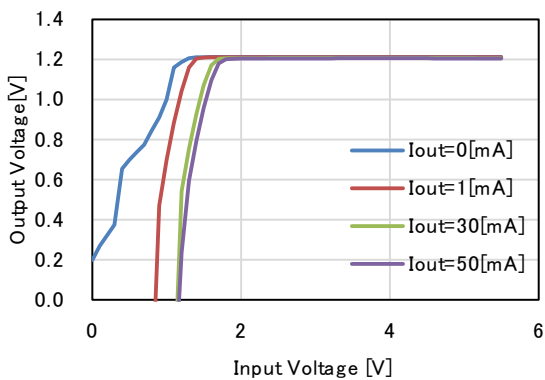

* Typical characteristics at $I_{OUT} = 1$ mA are evaluated in a fast response mode.

RP118x281x

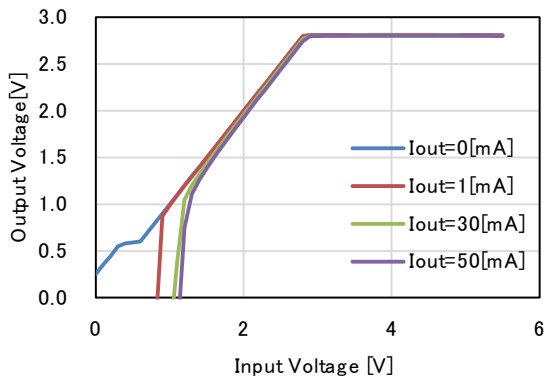

RP118x361x

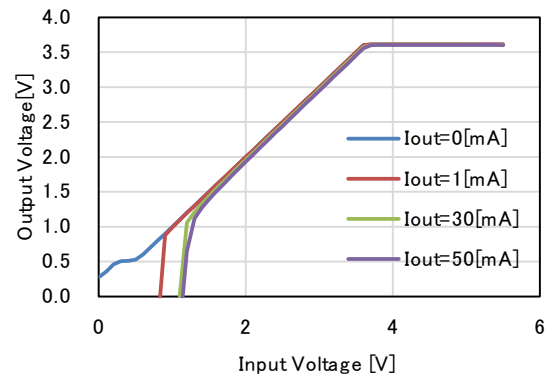

8) Supply Current vs. Input Voltage (C_{IN} = Ceramic 1.0 μ F, C_{OUT} = Ceramic 1.0 μ F, T_a = 25°C)
RP118x121x

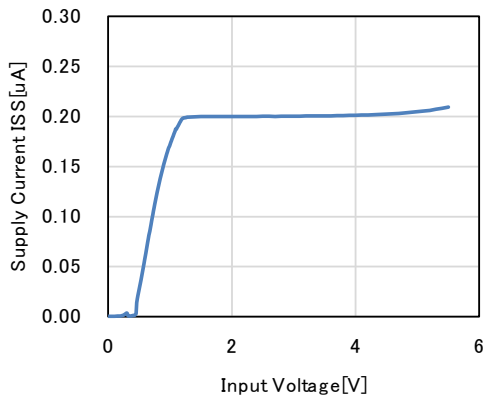

RP118x181x
(10 μ A/div)

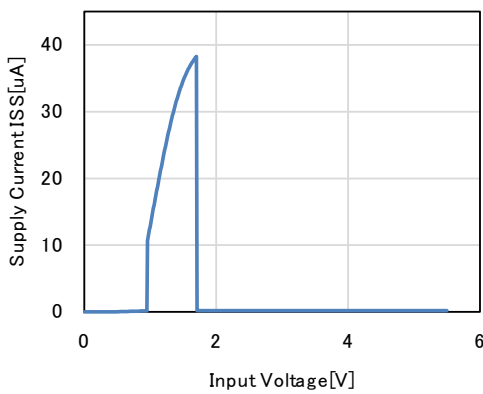

RP118x181x
(0.05 μ A/div)

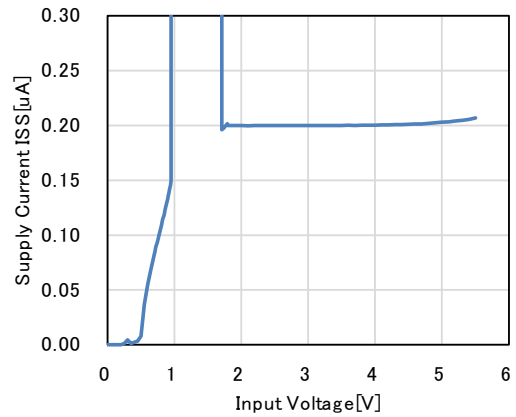

* Typical characteristics at $I_{OUT} = 1$ mA are evaluated in a fast response mode.

RP118x281x
(10 $\mu\text{A}/\text{div}$)

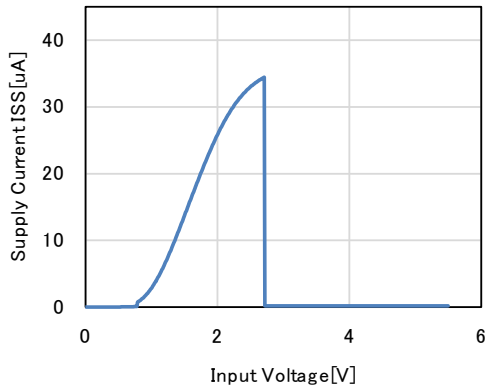

RP118x281x
(0.05 $\mu\text{A}/\text{div}$)

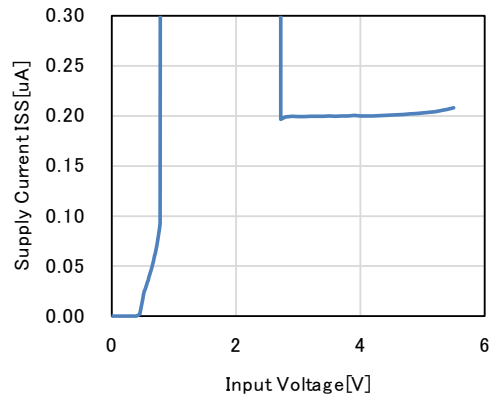

RP118x361x
(10 $\mu\text{A}/\text{div}$)

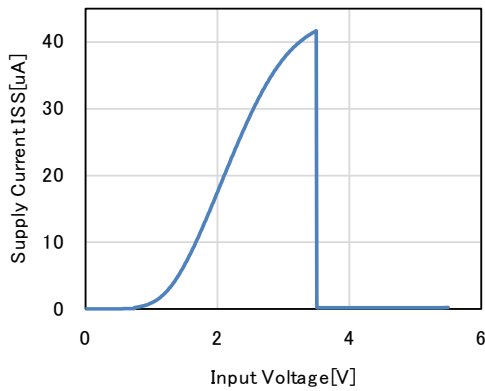

RP118x361x
(0.05 $\mu\text{A}/\text{div}$)

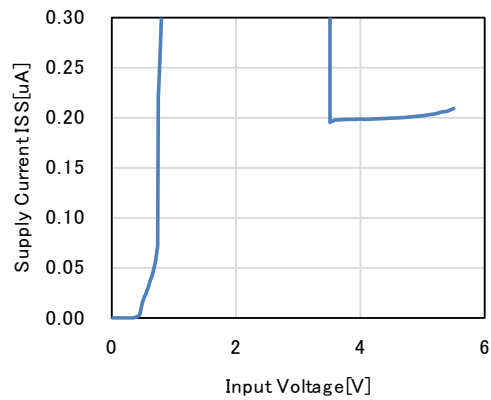

9) Supply Current vs. Output Current ($C_{\text{IN}} = \text{Ceramic } 1.0 \mu\text{F}$, $C_{\text{OUT}} = \text{Ceramic } 1.0 \mu\text{F}$, $T_a = 25^\circ\text{C}$)

RP118x121x

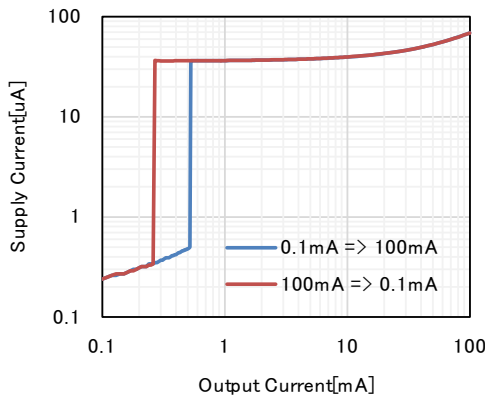

RP118x181x

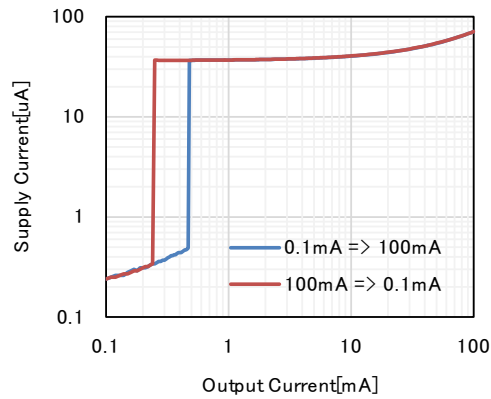

* Typical characteristics at $I_{\text{OUT}} = 1 \text{ mA}$ are evaluated in a fast response mode.

RP118x281x

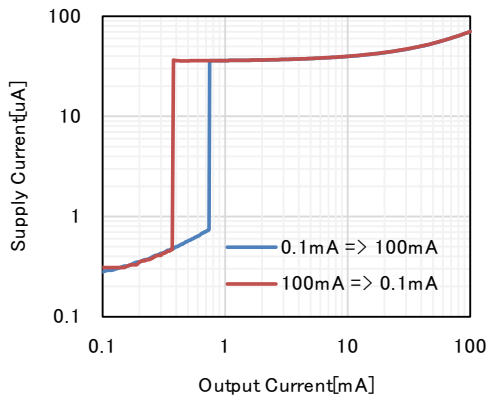

RP118x361x

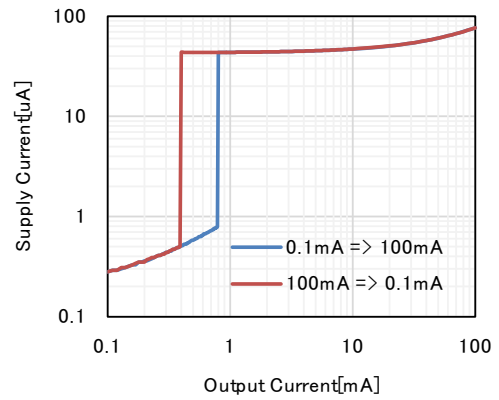

10) Ripple Rejection vs. Frequency (C_{IN} = none, C_{OUT} = Ceramic 1.0 μ F, T_a = 25°C)

RP118x121x, V_{IN} = 2.2 V

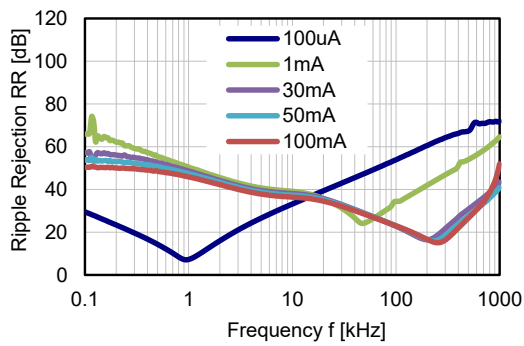

RP118x181x, V_{IN} = 2.8 V

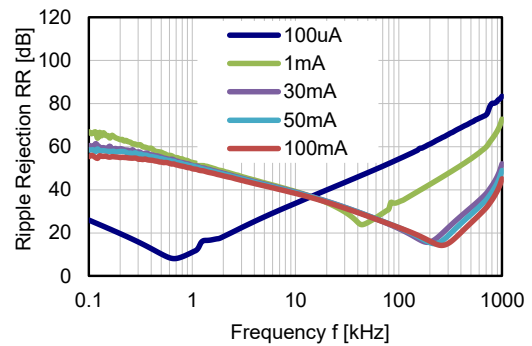

RP118x281x, V_{IN} = 3.8 V

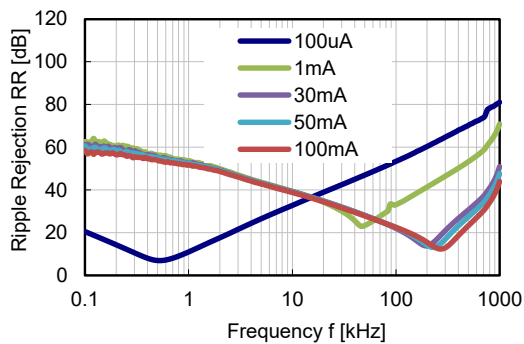

RP118x361x, V_{IN} = 4.6 V

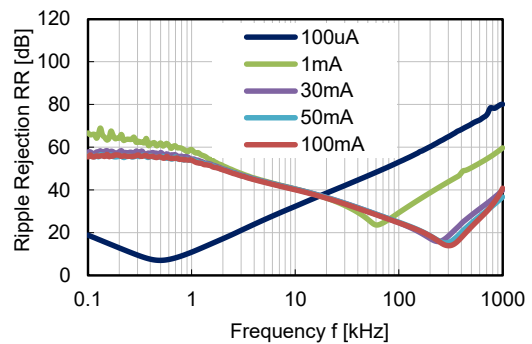

* Typical characteristics at I_{OUT} = 1 mA are evaluated in a fast response mode.

11) Ripple Rejection vs. Input Bias Voltage (C_{IN} = none, C_{OUT} = Ceramic 1.0 μ F, T_a = 25°C)
 RP118x121x, I_{OUT} = 100 μ A RP118x181x, I_{OUT} = 100 μ A

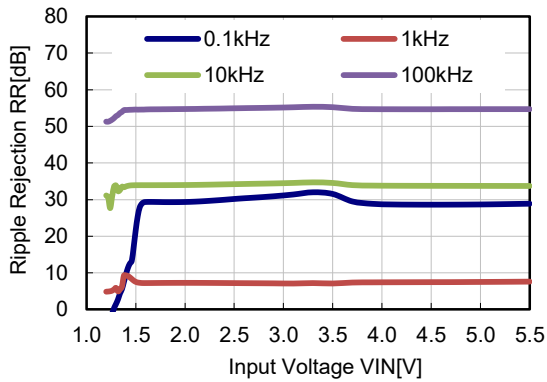

RP118x281x, I_{OUT} = 100 μ A

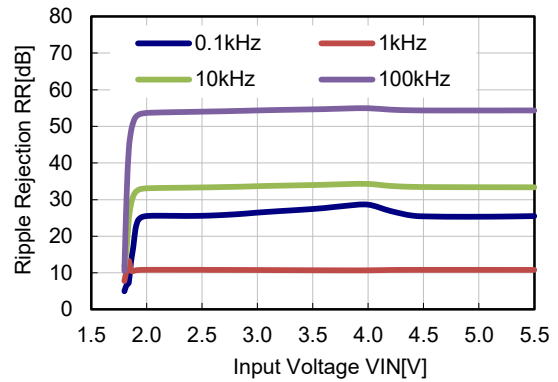

RP118x361x, I_{OUT} = 100 μ A

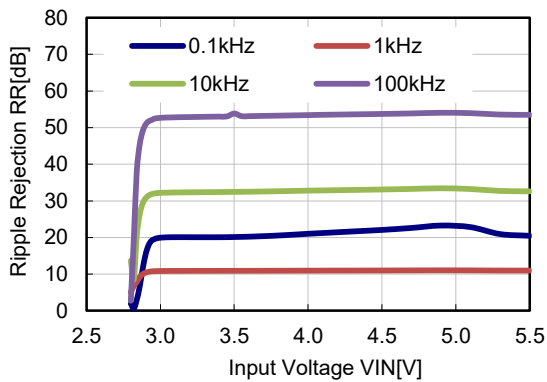

RP118x121x, I_{OUT} = 30 mA

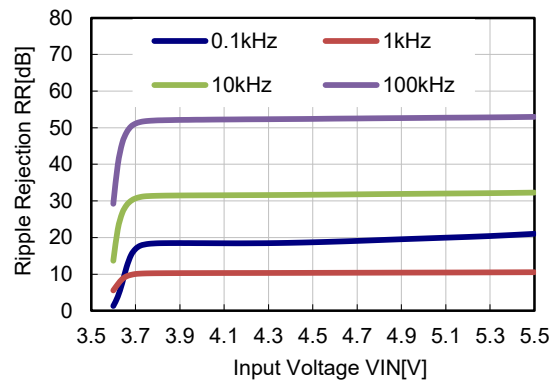

RP118x181x, I_{OUT} = 30 mA

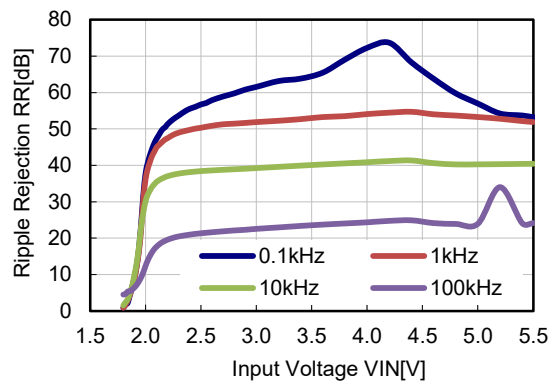
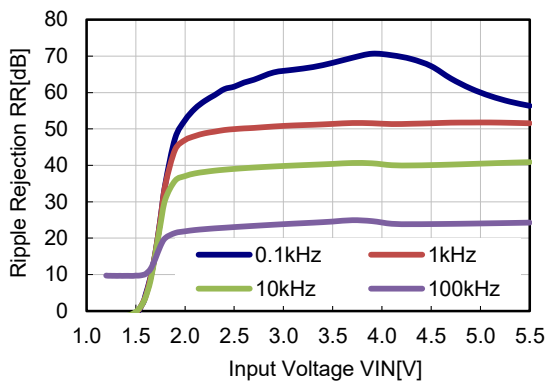

* Typical characteristics at $I_{OUT} = 1 mA$ are evaluated in a fast response mode.

RP118x281x, I_{OUT} = 30 mA

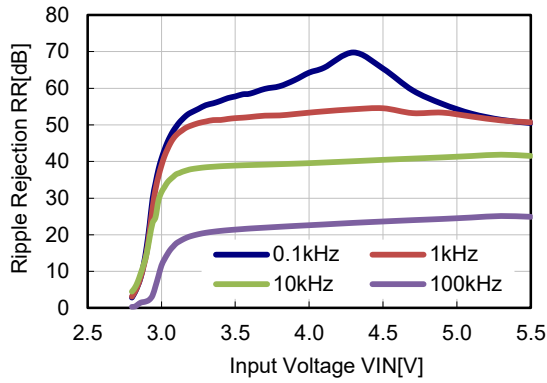

RP118x361x, I_{OUT} = 30 mA

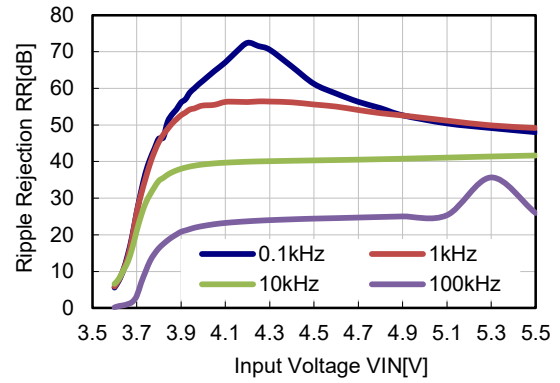

12) Input Transient Response (C_{IN} = Ceramic 0.1 μF, C_{OUT} = Ceramic 1.0 μF, Ta = 25°C)
 RP118x121x, I_{OUT} = 100 μA, t_R = t_F = 5 μs RP118x121x, I_{OUT} = 30 mA, t_R = t_F = 5 μs

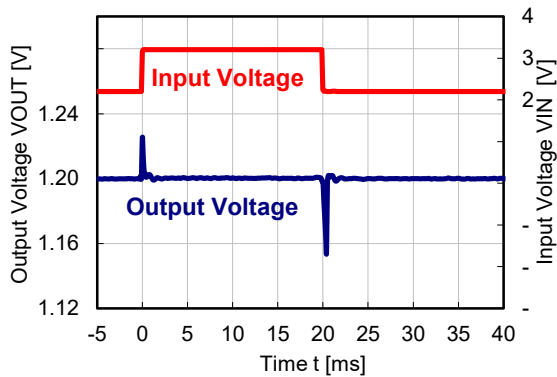

RP118x181x, I_{OUT} = 100 μA, t_R = t_F = 5 μs

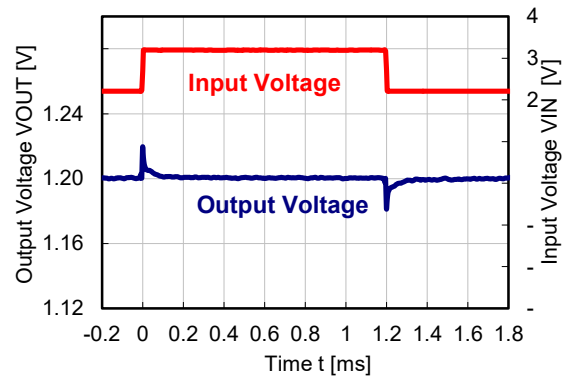

RP118x181x, I_{OUT} = 30 mA, t_R = t_F = 5 μs

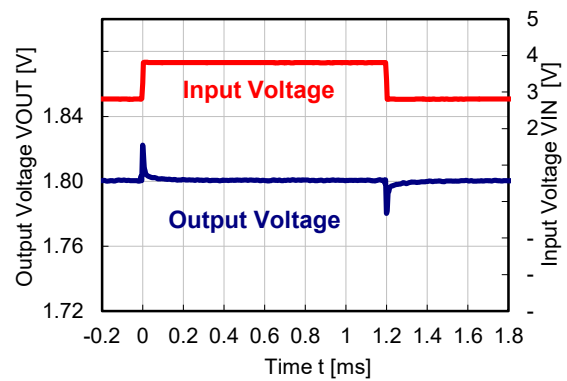
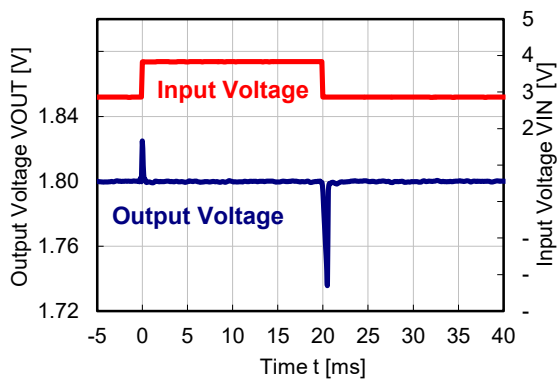

* Typical characteristics at I_{OUT} = 1 mA are evaluated in a fast response mode.

RP118x281x, $I_{OUT} = 100 \mu A$, $t_R = t_F = 5 \mu s$

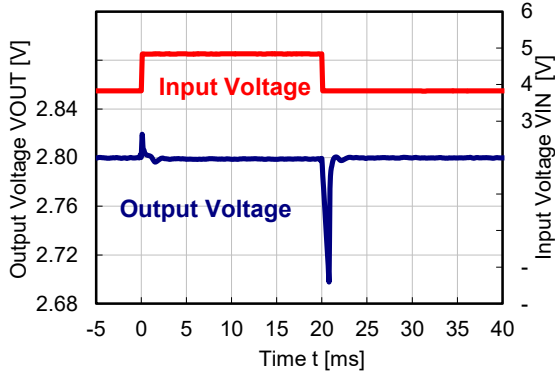

RP118x281x, $I_{OUT} = 30 mA$, $t_R = t_F = 5 \mu s$

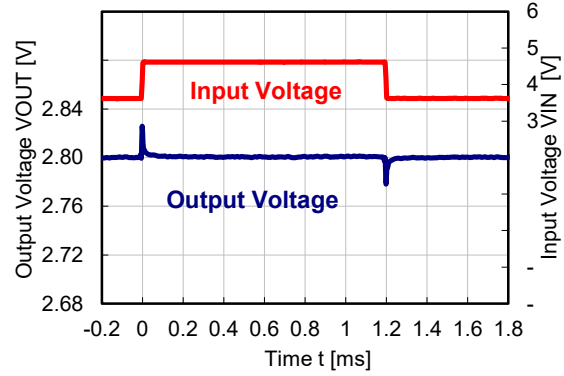

RP118x361x, $I_{OUT} = 100 \mu A$, $t_R = t_F = 5 \mu s$

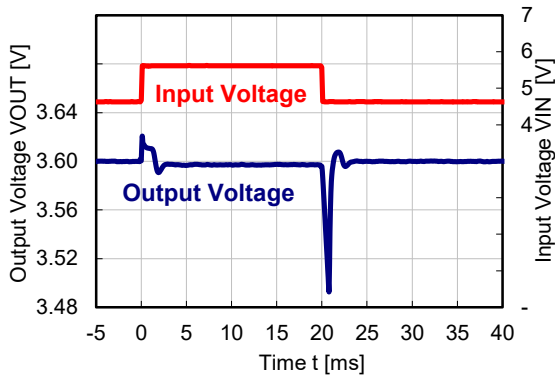

RP118x361x, $I_{OUT} = 30 mA$, $t_R = t_F = 5 \mu s$

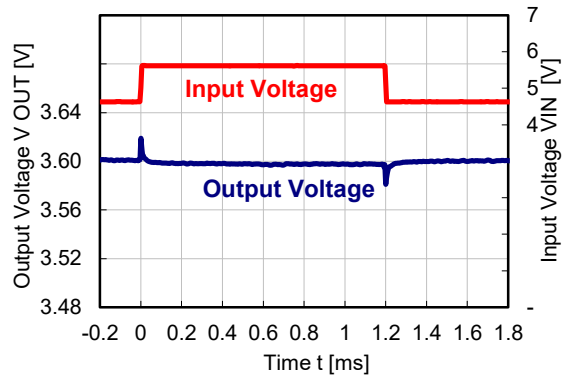

13) Load Transient Response ($C_{IN} = \text{Ceramic } 1.0 \mu F$, $C_{OUT} = \text{Ceramic } 1.0 \mu F$, $T_a = 25^\circ C$)

RP118x121x

$V_{IN} = 2.2 V$, $I_{OUT} = 1 \mu A \Leftrightarrow 10 mA$, $t_R = t_F = 5 \mu s$

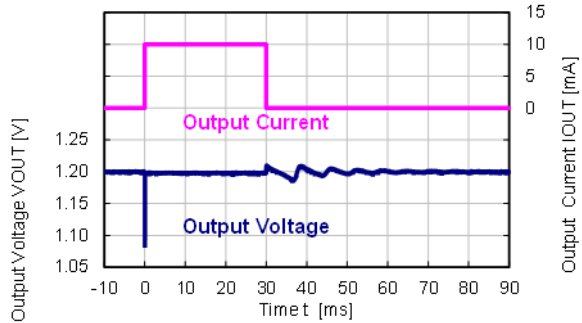

$V_{IN} = 2.2 V$, $I_{OUT} = 1 mA \Leftrightarrow 10 mA$, $t_R = t_F = 5 \mu s$

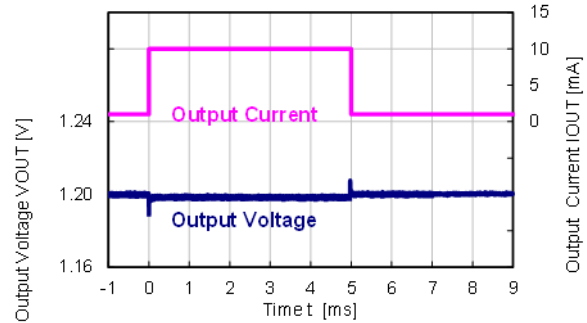

* Typical characteristics at $I_{OUT} = 1 mA$ are evaluated in a fast response mode.

$V_{IN} = 2.2\text{ V}$, $I_{OUT} = 10\text{ mA} \Leftrightarrow 30\text{ mA}$, $t_R = t_F = 5\text{ }\mu\text{s}$

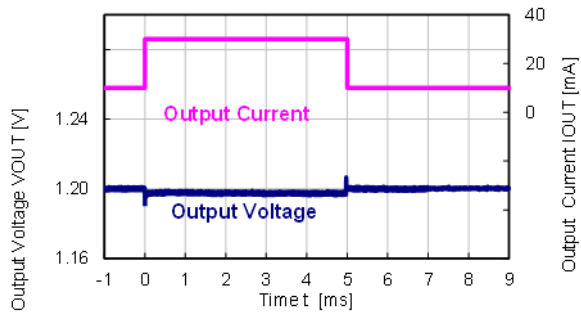

RP118x181x

$V_{IN} = 2.8\text{ V}$, $I_{OUT} = 1\text{ }\mu\text{A} \Leftrightarrow 10\text{ mA}$, $t_R = t_F = 5\text{ }\mu\text{s}$

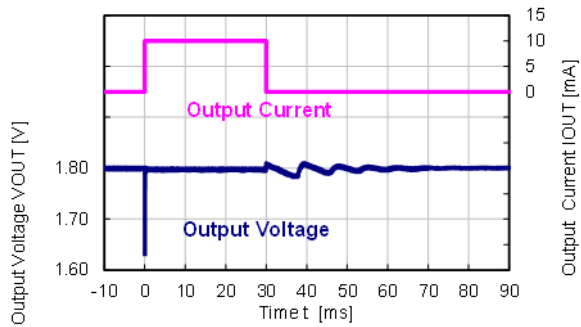

$V_{IN} = 2.8\text{ V}$, $I_{OUT} = 1\text{ mA} \Leftrightarrow 10\text{ mA}$, $t_R = t_F = 5\text{ }\mu\text{s}$

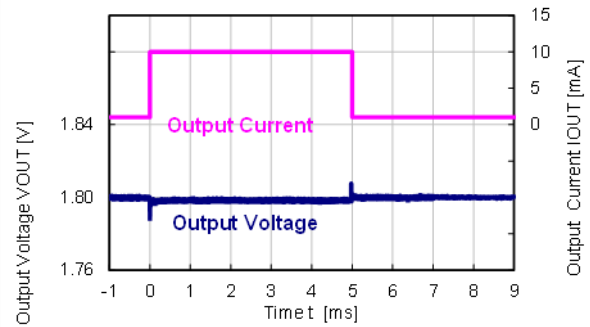

$V_{IN} = 2.8\text{ V}$, $I_{OUT} = 10\text{ mA} \Leftrightarrow 30\text{ mA}$, $t_R = t_F = 5\text{ }\mu\text{s}$

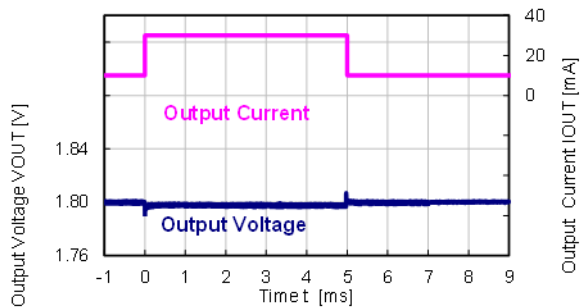

RP118x281x

$V_{IN} = 3.8\text{ V}$, $I_{OUT} = 1\text{ }\mu\text{A} \Leftrightarrow 10\text{ mA}$, $t_R = t_F = 5\text{ }\mu\text{s}$

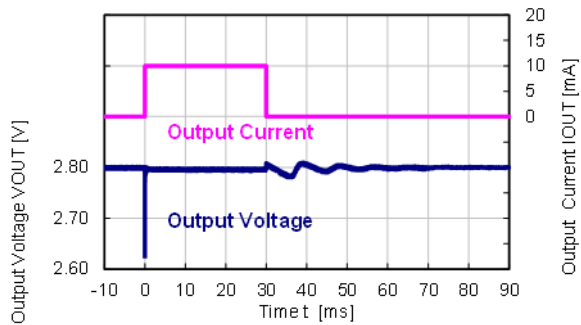

$V_{IN} = 3.8\text{ V}$, $I_{OUT} = 1\text{ mA} \Leftrightarrow 10\text{ mA}$, $t_R = t_F = 5\text{ }\mu\text{s}$

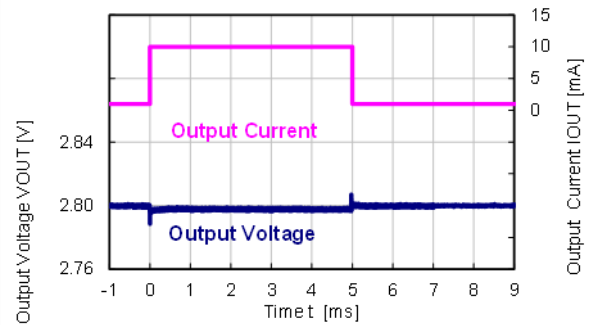

* Typical characteristics at $I_{OUT} = 1\text{ mA}$ are evaluated in a fast response mode.

$V_{IN} = 3.8\text{ V}$, $I_{OUT} = 10\text{ mA} \Leftrightarrow 30\text{ mA}$, $t_R = t_F = 5\ \mu\text{s}$

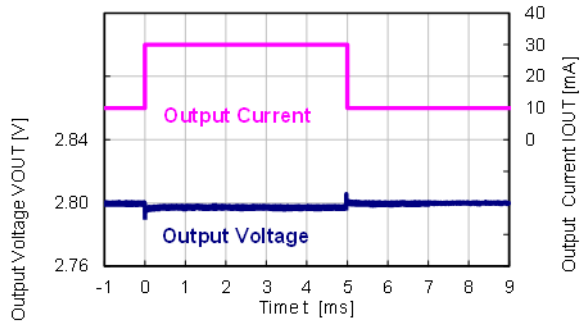

RP118x361x

$V_{IN} = 4.6\text{ V}$, $I_{OUT} = 1\ \mu\text{A} \Leftrightarrow 10\text{ mA}$, $t_R = t_F = 5\ \mu\text{s}$

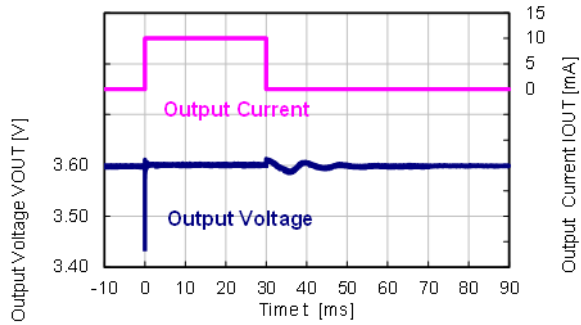

$V_{IN} = 4.6\text{ V}$, $I_{OUT} = 1\text{ mA} \Leftrightarrow 10\text{ mA}$, $t_R = t_F = 5\ \mu\text{s}$

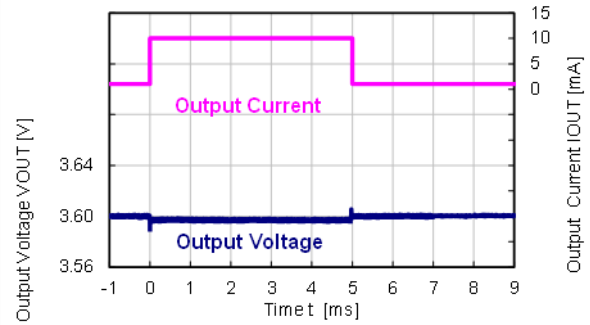

$V_{IN} = 4.6\text{ V}$, $I_{OUT} = 10\text{ mA} \Leftrightarrow 30\text{ mA}$, $t_R = t_F = 5\ \mu\text{s}$

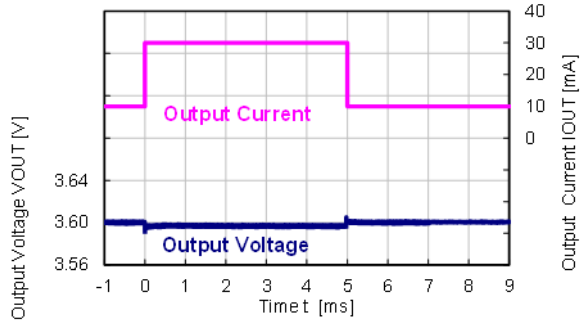

* Typical characteristics at $I_{OUT} = 1\text{ mA}$ are evaluated in a fast response mode.

14) Turn On Speed with CE pin (C_{IN} = Ceramic 1.0 μ F, C_{OUT} = Ceramic 1.0 μ F, T_a = 25°C)

RP118x121x

$V_{IN} = 2.2\text{ V}$, $V_{CE} = 0\text{ V} \Rightarrow 2.2\text{ V}$

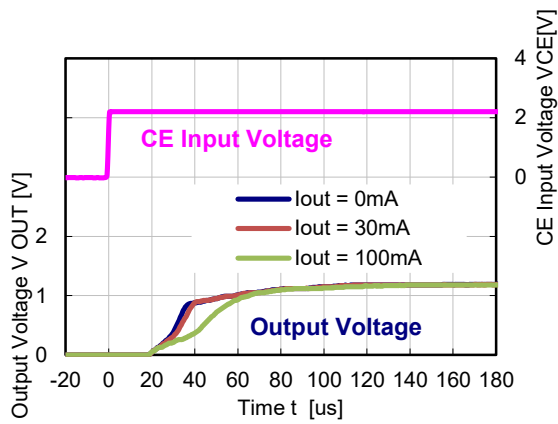

RP118x181x

$V_{IN} = 2.8\text{ V}$, $V_{CE} = 0\text{ V} \Rightarrow 2.8\text{ V}$

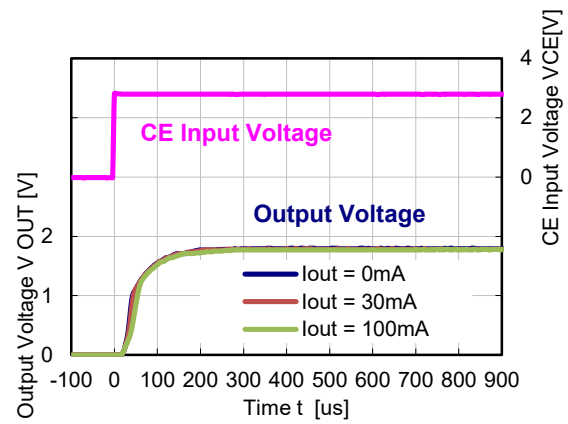

RP118x281x

$V_{IN} = 3.8\text{ V}$, $V_{CE} = 0\text{ V} \Rightarrow 3.8\text{ V}$

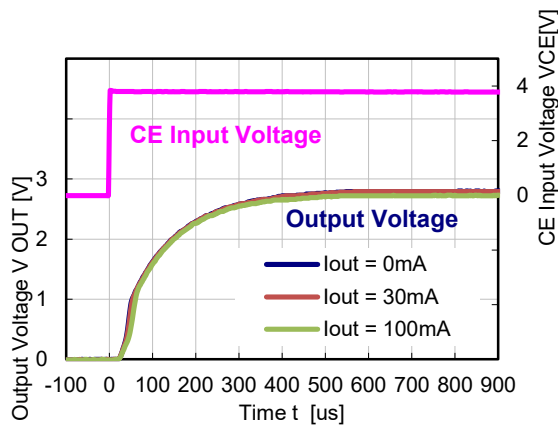

RP118x361x

$V_{IN} = 4.6\text{ V}$, $V_{CE} = 0\text{ V} \Rightarrow 4.6\text{ V}$

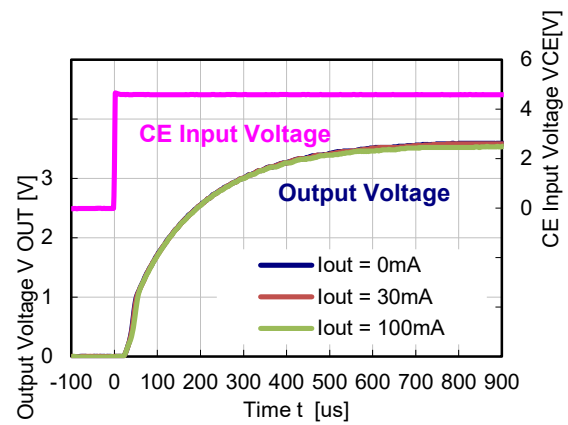

* Typical characteristics at $I_{OUT} = 1\text{ mA}$ are evaluated in a fast response mode.

15) Turn OFF Speed with CE pin ($C_{IN} = \text{Ceramic } 1.0 \mu\text{F}$, $C_{OUT} = \text{Ceramic } 1.0 \mu\text{F}$, $T_a = 25^\circ\text{C}$)

RP118x121D

$V_{IN} = 2.2 \text{ V}$, $V_{CE} = 2.2 \text{ V} \Rightarrow 0 \text{ V}$

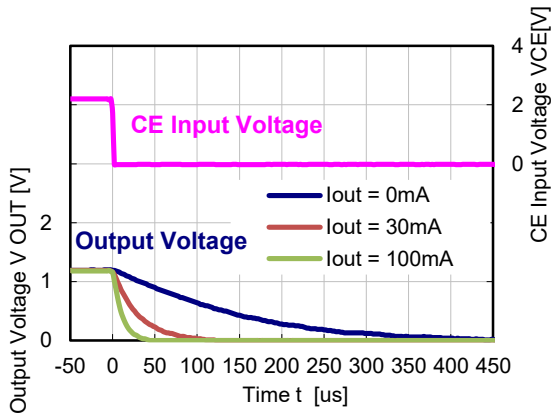

RP118x281D

$V_{IN} = 3.8 \text{ V}$, $V_{CE} = 3.8 \text{ V} \Rightarrow 0 \text{ V}$

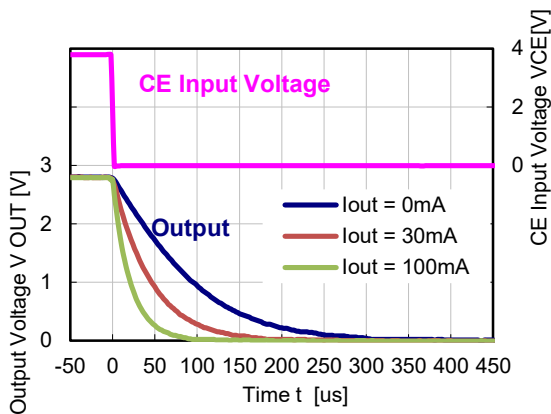

RP118x181D

$V_{IN} = 2.8 \text{ V}$, $V_{CE} = 2.8 \text{ V} \Rightarrow 0 \text{ V}$

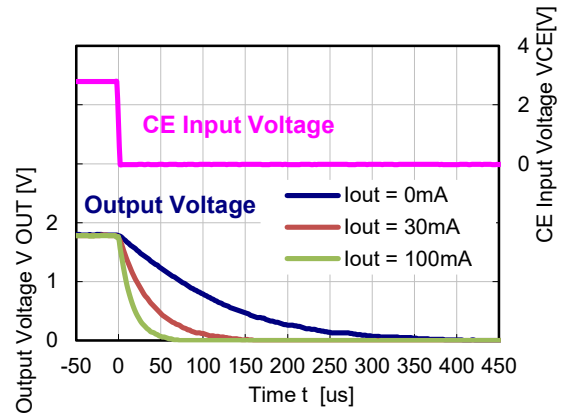

RP118x361D

$V_{IN} = 4.6 \text{ V}$, $V_{CE} = 4.6 \text{ V} \Rightarrow 0 \text{ V}$

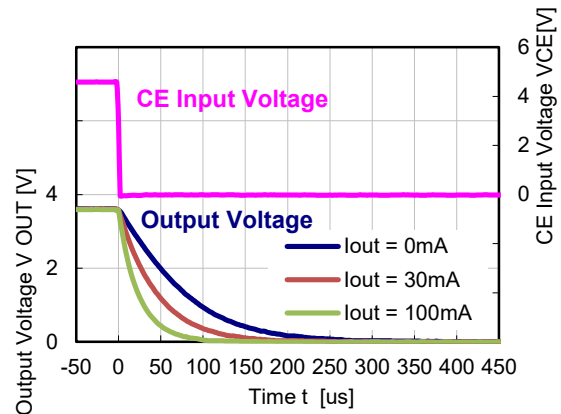

* Typical characteristics at $I_{OUT} = 1 \text{ mA}$ are evaluated in a fast response mode.

16) Inrush Current at turning on ($C_{IN} = \text{none}$, $T_a = 25^\circ\text{C}$)

RP118x121x

$V_{IN} = 2.2\text{ V}$, $V_{CE} = 0\text{ V} \Rightarrow 2.2\text{ V}$

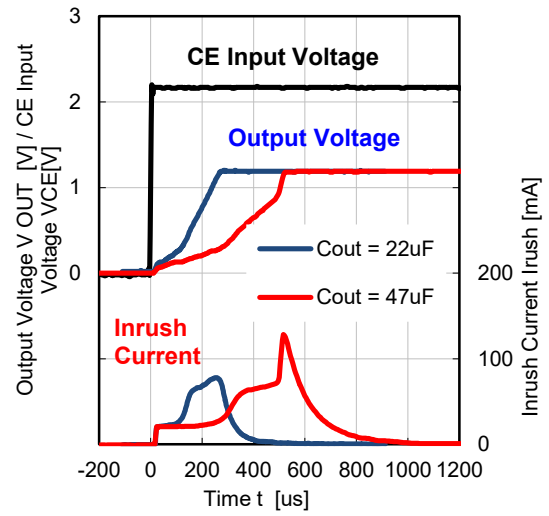
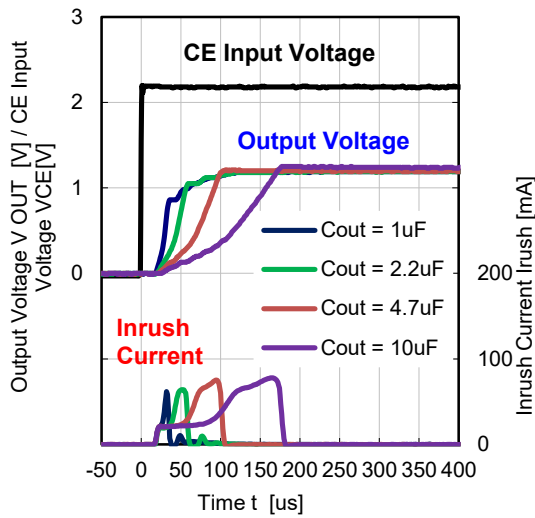

RP118x181x

$V_{IN} = 2.8\text{ V}$, $V_{CE} = 0\text{ V} \Rightarrow 2.8\text{ V}$

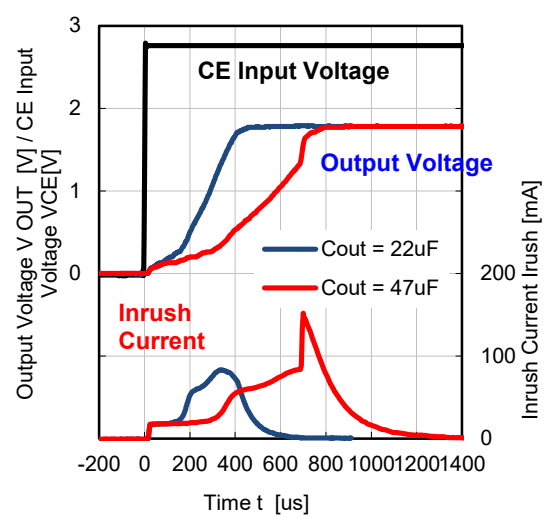
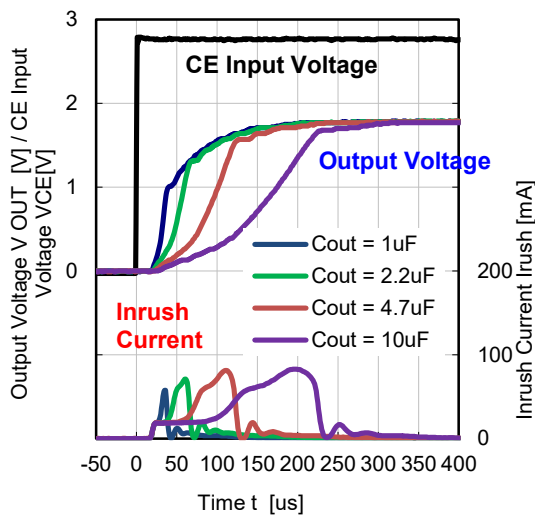

* Typical characteristics at $I_{OUT} = 1\text{ mA}$ are evaluated in a fast response mode.

RP118x281x

$V_{IN} = 3.8\text{ V}, V_{CE} = 0\text{ V} \Rightarrow 3.8\text{ V}$

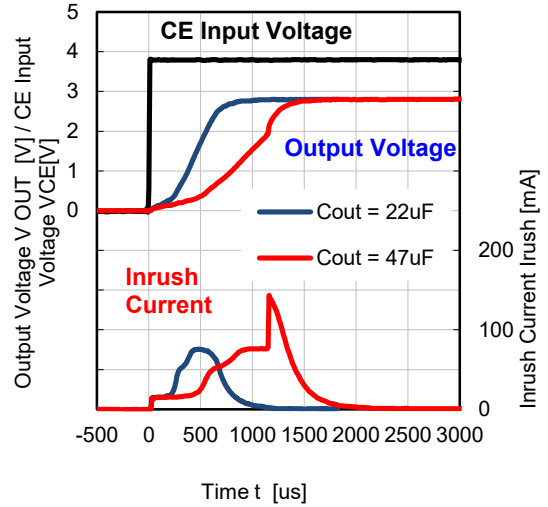
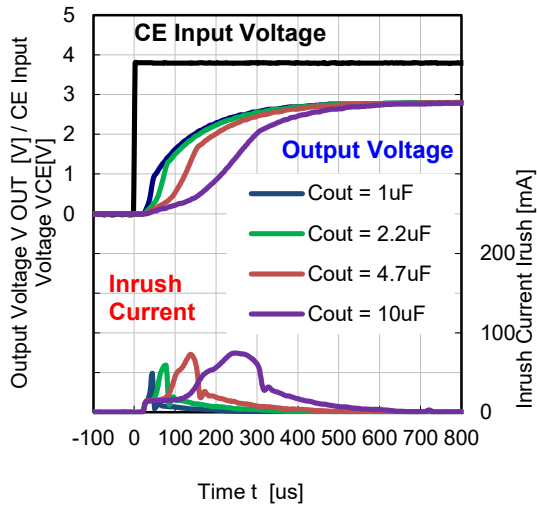

RP118x361x

$V_{IN} = 4.6\text{ V}, V_{CE} = 0\text{ V} \Rightarrow 4.6\text{ V}$

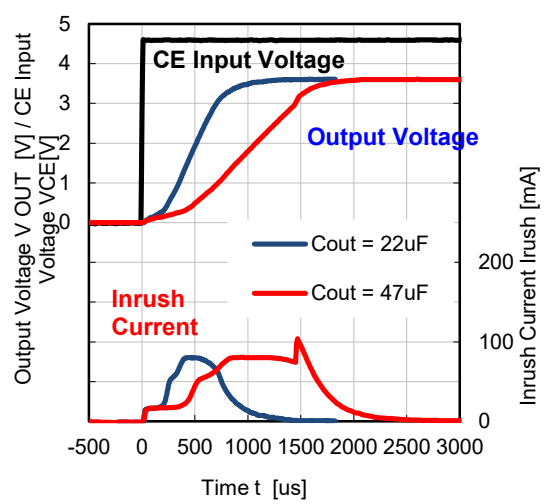
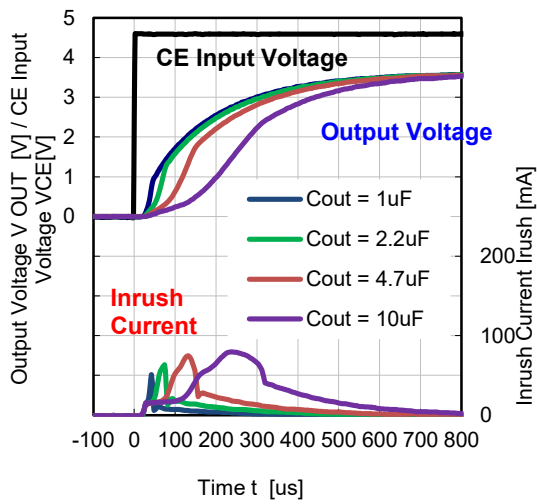

* Typical characteristics at $I_{OUT} = 1\text{ mA}$ are evaluated in a fast response mode.

ESR vs. Output Current

It is recommended that a ceramic type capacitor be used for this device. However, other types of capacitors having lower ESR can also be used. The relation between the output current (I_{OUT}) and the ESR of output capacitor is shown below.

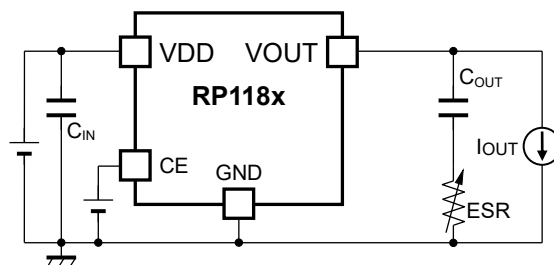

Measurement conditions

Frequency Band : 10 Hz to 2 MHz

Temperature : -40°C to 85°C

C_{IN} , C_{OUT} : Ceramic $1.0\ \mu\text{F}$

RP118x121x
 $V_{IN} = 1.7\ \text{V to } 5.5\ \text{V}$

RP118x181x
 $V_{IN} = 1.8\ \text{V to } 5.5\ \text{V}$

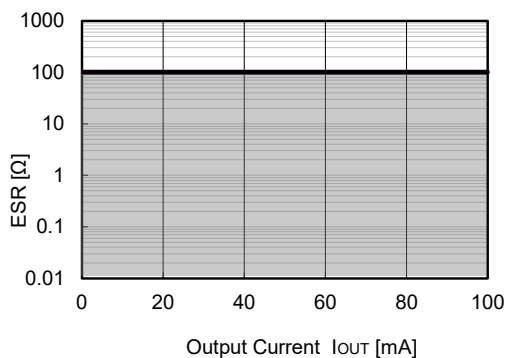

RP118x281x
 $V_{IN} = 2.8\ \text{V to } 5.5\ \text{V}$

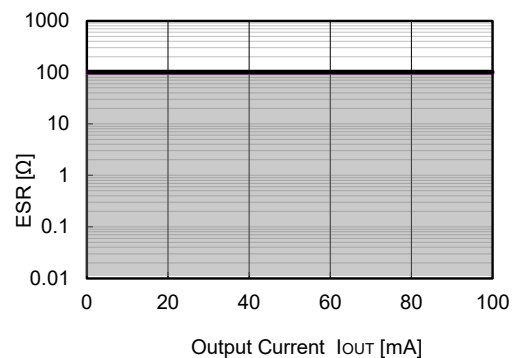

RP118x361x
 $V_{IN} = 3.6\ \text{V to } 5.5\ \text{V}$

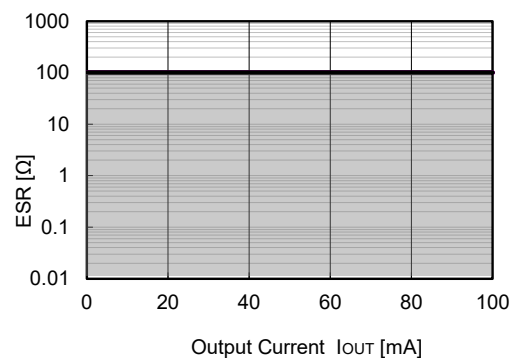
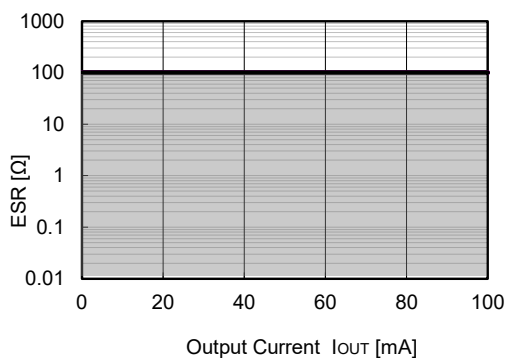

The power dissipation of the package is dependent on PCB material, layout, and environmental conditions. The following measurement conditions are based on JEDEC STD. 51-9.

Measurement Conditions

Item	Measurement Conditions
Environment	Mounting on Board (Wind Velocity = 0 m/s)
Board Material	Glass Cloth Epoxy Plastic (Four-Layer Board)
Board Dimensions	101.5 mm x 114.5 mm x 1.6 mm
Copper Ratio	Outer Layer (First Layer): 60% Inner Layers (Second and Third Layers): 100% Outer Layer (Fourth Layer): 60%

Measurement Result

(Ta = 25°C, Tjmax = 125°C)

Item	Measurement Result
Power Dissipation	470 mW
Thermal Resistance (θ_{ja})	$\theta_{ja} = 212^{\circ}\text{C/W}$

θ_{ja} : Junction-to-Ambient Thermal Resistance

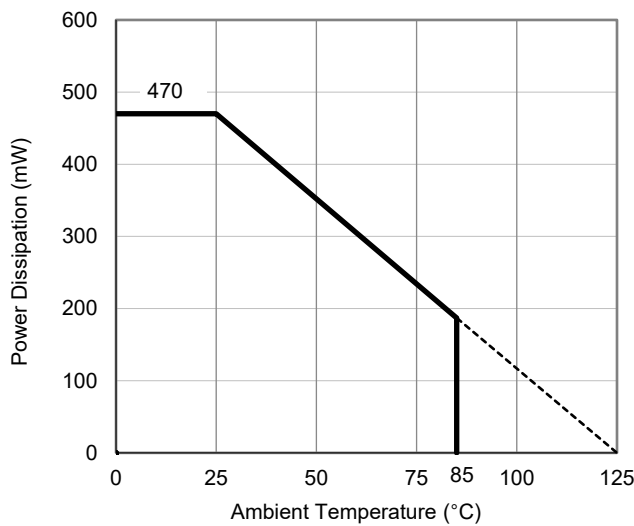

Power Dissipation vs. Ambient Temperature

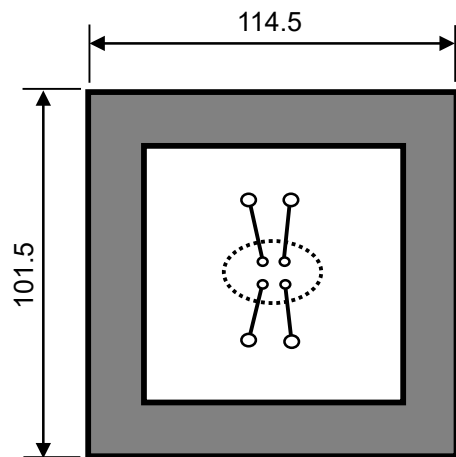

Measurement Board Pattern

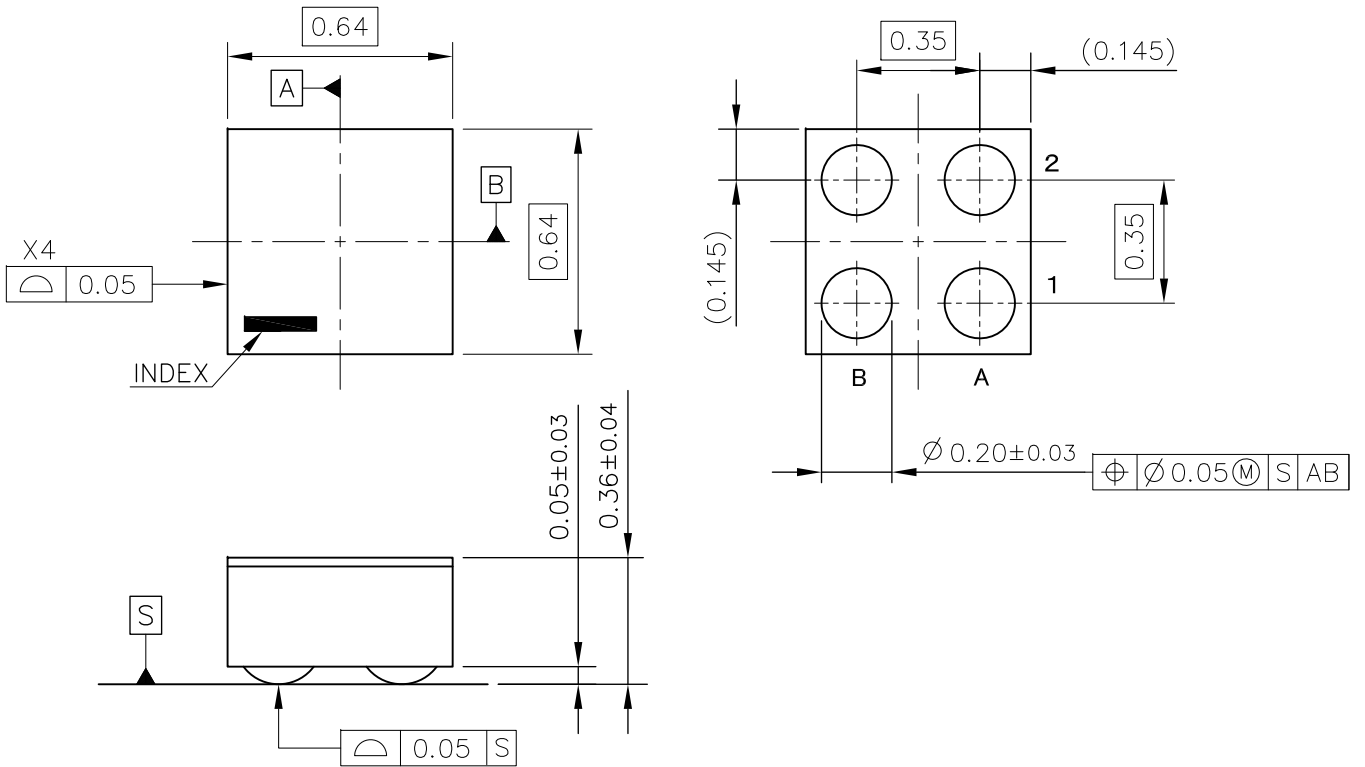

WLCSP-4-P8 Package Dimensions (Unit: mm)

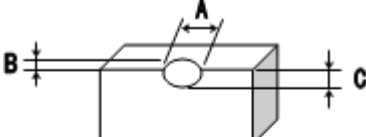
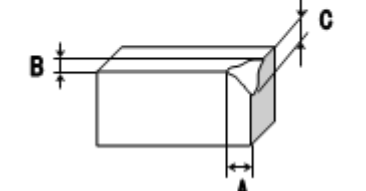
No.	Inspection Items	Inspection Criteria	Figure
1	Package chipping	<p>$A \geq 0.2\text{mm}$ is rejected $B \geq 0.2\text{mm}$ is rejected $C \geq 0.2\text{mm}$ is rejected And, Package chipping to Si surface and to bump is rejected.</p>	
2	Si surface chipping	<p>$A \geq 0.2\text{mm}$ is rejected $B \geq 0.2\text{mm}$ is rejected $C \geq 0.2\text{mm}$ is rejected But, even if $A \geq 0.2\text{mm}$, $B \leq 0.1\text{mm}$ is acceptable.</p>	
3	No bump	No bump is rejected.	
4	Marking miss	To reject incorrect marking, such as another product name marking or another lot No. marking.	
5	No marking	To reject no marking on the package.	
6	Reverse direction of marking	To reject reverse direction of marking character.	
7	Defective marking	To reject unreadable marking. (Microscope: X15/ White LED/ Viewed from vertical direction)	
8	Scratch	To reject unreadable marking character by scratch. (Microscope: X15/ White LED/ Viewed from vertical direction)	
9	Stain and Foreign material	To reject unreadable marking character by stain and foreign material. (Microscope: X15/ White LED/ Viewed from vertical direction)	

①②: Lot Number ··· Alphanumeric Serial Number

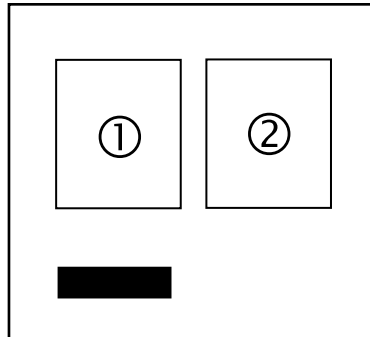

RP118Z (WLCSP-4-P8) Part Markings

NOTICE

There can be variation in the marking when different AOI (Automated Optical Inspection) equipment is used. In the case of recognizing the marking characteristic with AOI, please contact our sales or distributor before attempting to use AOI.

RP118Z Part Marking List

Product Name	① ②
RP118Z121B	Lot No
RP118Z161B	Lot No
RP118Z181B	Lot No
RP118Z301B	Lot No
RP118Z331B	Lot No
RP118Z121B5	Lot No

Product Name	① ②
RP118Z121D	Lot No
RP118Z161D	Lot No
RP118Z181D	Lot No
RP118Z301D	Lot No
RP118Z331D	Lot No
RP118Z121D5	Lot No

The power dissipation of the package is dependent on PCB material, layout, and environmental conditions. The following measurement conditions are based on JEDEC STD. 51.

Measurement Conditions

Item	Measurement Conditions
Environment	Mounting on Board (Wind Velocity = 0 m/s)
Board Material	Glass Cloth Epoxy Plastic (Four-Layer Board)
Board Dimensions	76.2 mm × 114.3 mm × 0.8 mm
Copper Ratio	Outer Layer (First Layer): Less than 95% of 50 mm Square Inner Layers (Second and Third Layers): Approx. 100% of 50 mm Square Outer Layer (Fourth Layer): Approx. 100% of 50 mm Square
Through-holes	φ 0.2 mm × 21 pcs

Measurement Result

(Ta = 25°C, Tjmax = 125°C)

Item	Measurement Result
Power Dissipation	510 mW
Thermal Resistance (θ_{ja})	$\theta_{ja} = 194^{\circ}\text{C/W}$
Thermal Characterization Parameter (ψ_{jt})	$\psi_{jt} = 120^{\circ}\text{C/W}$

θ_{ja} : Junction-to-Ambient Thermal Resistance

ψ_{jt} : Junction-to-Top Thermal Characterization Parameter

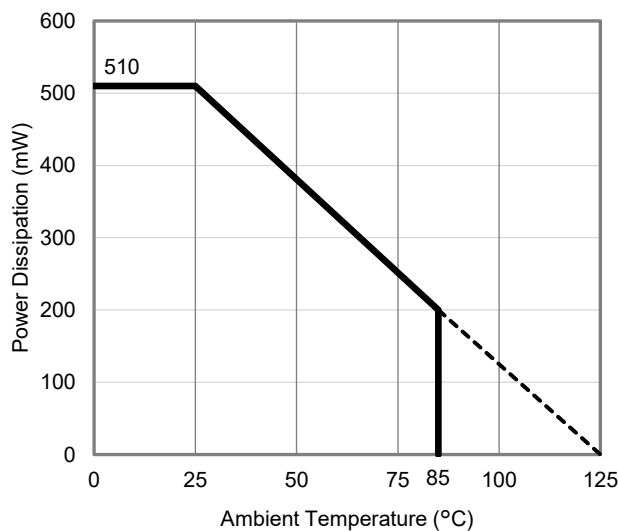

Power Dissipation vs. Ambient Temperature

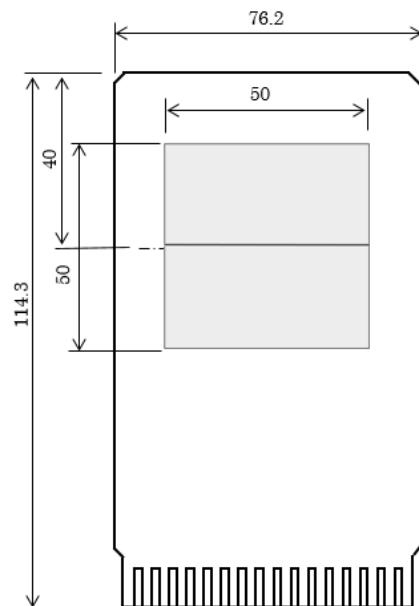

Measurement Board Pattern

PACKAGE DIMENSIONS

DFN(PL)1010-4B

DM-DFN(PL)1010-4B-JE-C

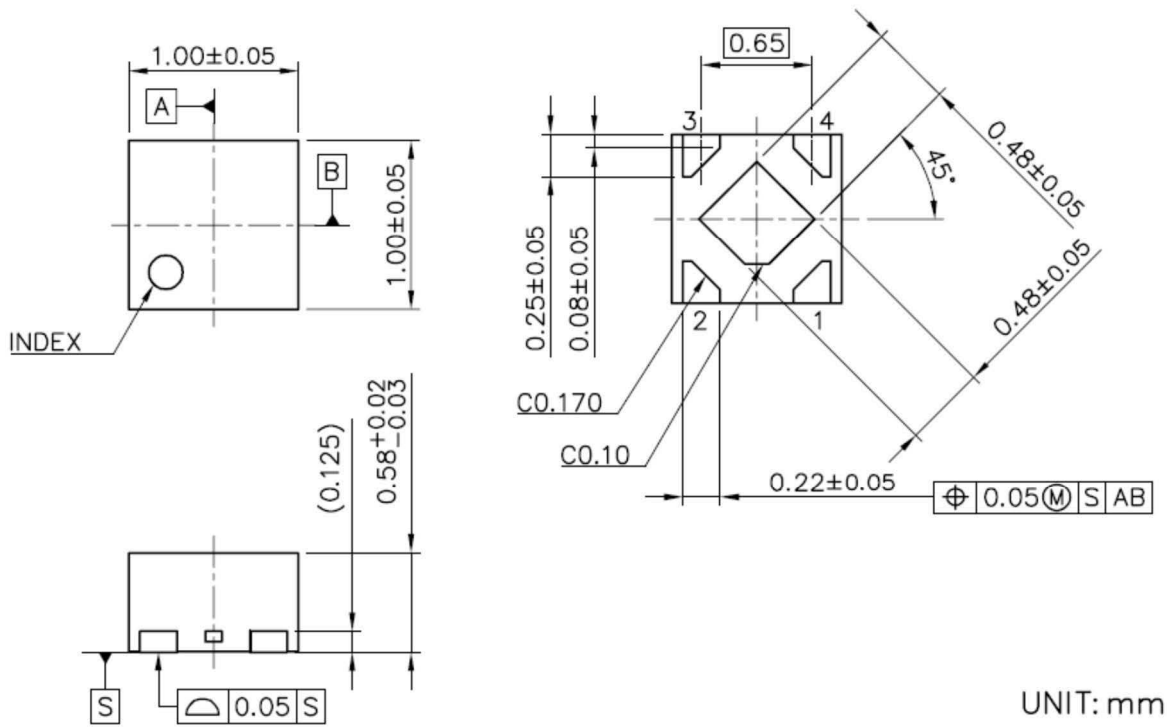

UNIT: mm

DFN(PL)1010-4B Package Dimensions

①②: Product Code ... Refer to *Part Marking List*

③④: Lot Number ... Alphanumeric Serial Number

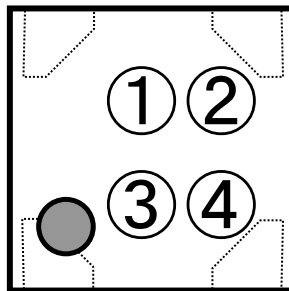

DFN(PL)1010-4B Part Markings

NOTICE

There can be variation in the marking when different AOI (Automated Optical Inspection) equipment is used. In the case of recognizing the marking characteristic with AOI, please contact our sales or distributor before attempting to use AOI.

RP118K Part Marking List**RP118Kxx1B**

Product Name	①	②
RP118K121B	A	0
RP118K131B	A	1
RP118K141B	A	2
RP118K151B	A	3
RP118K161B	A	4
RP118K171B	A	5
RP118K181B	A	6
RP118K191B	A	7
RP118K201B	A	8
RP118K211B	A	9
RP118K221B	B	0
RP118K231B	B	1
RP118K241B	B	2
RP118K251B	B	3
RP118K261B	B	4
RP118K271B	B	5
RP118K281B	B	6
RP118K291B	B	7
RP118K301B	B	8
RP118K311B	B	9
RP118K321B	C	0
RP118K331B	C	1
RP118K341B	C	2
RP118K351B	C	3
RP118K361B	C	4
RP118K181B5	C	5
RP118K121B5	C	6

RP118Kxx1D

Product Name	①	②
RP118K121D	D	0
RP118K131D	D	1
RP118K141D	D	2
RP118K151D	D	3
RP118K161D	D	4
RP118K171D	D	5
RP118K181D	D	6
RP118K191D	D	7
RP118K201D	D	8
RP118K211D	D	9
RP118K221D	E	0
RP118K231D	E	1
RP118K241D	E	2
RP118K251D	E	3
RP118K261D	E	4
RP118K271D	E	5
RP118K281D	E	6
RP118K291D	E	7
RP118K301D	E	8
RP118K311D	E	9
RP118K321D	F	0
RP118K331D	F	1
RP118K341D	F	2
RP118K351D	F	3
RP118K361D	F	4
RP118K181D5	F	5
RP118K121D5	F	6

The power dissipation of the package is dependent on PCB material, layout, and environmental conditions. The following measurement conditions are based on JEDEC STD. 51-7.

Measurement Conditions

Item	Measurement Conditions
Environment	Mounting on Board (Wind Velocity = 0 m/s)
Board Material	Glass Cloth Epoxy Plastic (Four-Layer Board)
Board Dimensions	76.2 mm × 114.3 mm × 0.8 mm
Copper Ratio	Outer Layer (First Layer): Less than 95% of 50 mm Square Inner Layers (Second and Third Layers): Approx. 100% of 50 mm Square Outer Layer (Fourth Layer): Approx. 100% of 50 mm Square
Through-holes	φ 0.3 mm × 7 pcs

Measurement Result

(Ta = 25°C, Tjmax = 125°C)

Item	Measurement Result
Power Dissipation	660 mW
Thermal Resistance (θja)	θja = 150°C/W
Thermal Characterization Parameter (ψjt)	ψjt = 51°C/W

θja: Junction-to-Ambient Thermal Resistance

ψjt: Junction-to-Top Thermal Characterization Parameter

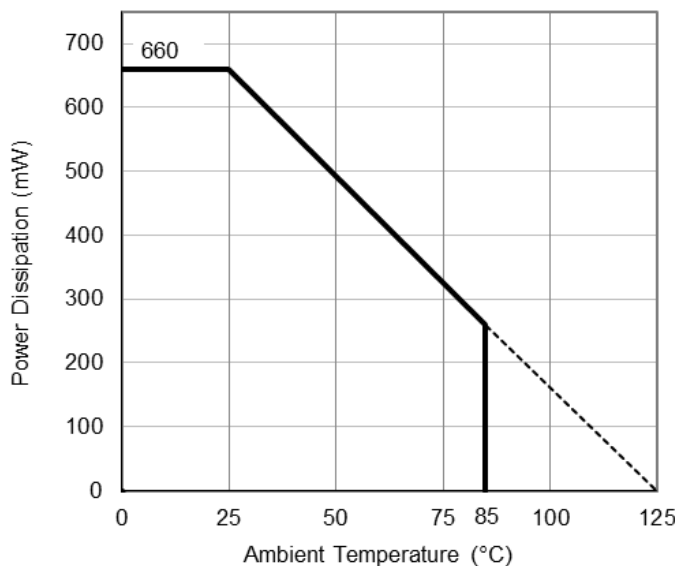

Power Dissipation vs. Ambient Temperature

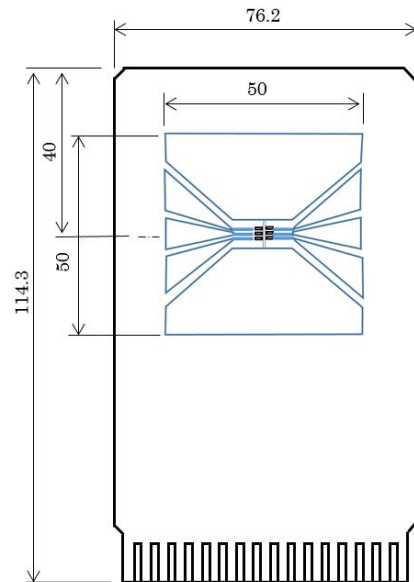

Measurement Board Pattern

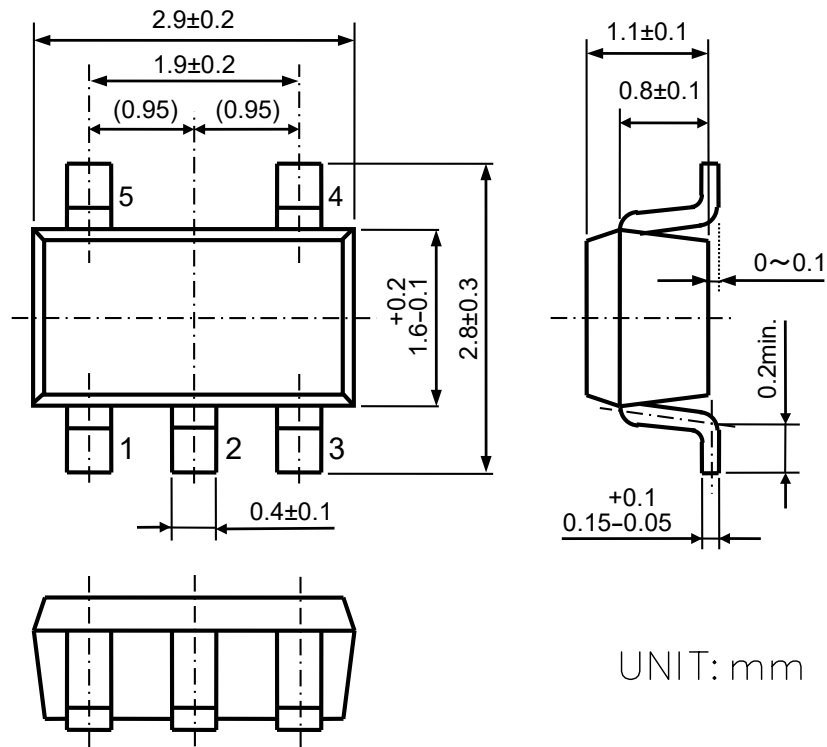

SOT-23-5 Package Dimensions

①②③: Product Code ... Refer to *Part Marking List*

④⑤: Lot Number ... Alphanumeric Serial Number

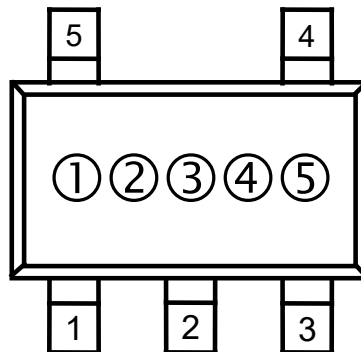

RP118N (SOT-23-5) Part Markings

NOTICE

There can be variation in the marking when different AOI (Automated Optical Inspection) equipment is used. In the case of recognizing the marking characteristic with AOI, please contact our sales or distributor before attempting to use AOI.

RP118N Part Marking List

Product Name	①	②	③
RP118N121B	E	A	0
RP118N131B	E	A	1
RP118N141B	E	A	2
RP118N151B	E	A	3
RP118N161B	E	A	4
RP118N171B	E	A	5
RP118N181B	E	A	6
RP118N181B5	E	A	7
RP118N191B	E	A	8
RP118N201B	E	A	9
RP118N211B	E	B	0
RP118N221B	E	B	1
RP118N231B	E	B	2
RP118N241B	E	B	3
RP118N251B	E	B	4
RP118N261B	E	B	5
RP118N271B	E	B	6
RP118N281B	E	B	7
RP118N291B	E	B	8
RP118N301B	E	B	9
RP118N311B	E	C	0
RP118N321B	E	C	1
RP118N331B	E	C	2
RP118N341B	E	C	3
RP118N351B	E	C	4
RP118N361B	E	C	5
RP118N121B5	E	C	6

Product Name	①	②	③
RP118N121D	E	D	0
RP118N131D	E	D	1
RP118N141D	E	D	2
RP118N151D	E	D	3
RP118N161D	E	D	4
RP118N171D	E	D	5
RP118N181D	E	D	6
RP118N181D5	E	D	7
RP118N191D	E	D	8
RP118N201D	E	D	9
RP118N211D	E	F	0
RP118N221D	E	F	1
RP118N231D	E	F	2
RP118N241D	E	F	3
RP118N251D	E	F	4
RP118N261D	E	F	5
RP118N271D	E	F	6
RP118N281D	E	F	7
RP118N291D	E	F	8
RP118N301D	E	F	9
RP118N311D	E	G	0
RP118N321D	E	G	1
RP118N331D	E	G	2
RP118N341D	E	G	3
RP118N351D	E	G	4
RP118N361D	E	G	5
RP118N121D5	E	G	6

1. The products and the product specifications described in this document are subject to change or discontinuation of production without notice for reasons such as improvement. Therefore, before deciding to use the products, please refer to our sales representatives for the latest information thereon.
2. The materials in this document may not be copied or otherwise reproduced in whole or in part without the prior written consent of us.
3. This product and any technical information relating thereto are subject to complementary export controls (so-called KNOW controls) under the Foreign Exchange and Foreign Trade Law, and related politics ministerial ordinance of the law. (Note that the complementary export controls are inapplicable to any application-specific products, except rockets and pilotless aircraft, that are insusceptible to design or program changes.) Accordingly, when exporting or carrying abroad this product, follow the Foreign Exchange and Foreign Trade Control Law and its related regulations with respect to the complementary export controls.
4. The technical information described in this document shows typical characteristics and example application circuits for the products. The release of such information is not to be construed as a warranty of or a grant of license under our or any third party's intellectual property rights or any other rights.
5. The products listed in this document are intended and designed for use as general electronic components in standard applications (office equipment, telecommunication equipment, measuring instruments, consumer electronic products, amusement equipment etc.). Those customers intending to use a product in an application requiring extreme quality and reliability, for example, in a highly specific application where the failure or misoperation of the product could result in human injury or death should first contact us.
 - Aerospace Equipment
 - Equipment Used in the Deep Sea
 - Power Generator Control Equipment (nuclear, steam, hydraulic, etc.)
 - Life Maintenance Medical Equipment
 - Fire Alarms / Intruder Detectors
 - Vehicle Control Equipment (automotive, airplane, railroad, ship, etc.)
 - Various Safety Devices
 - Traffic control system
 - Combustion equipment

In case your company desires to use this product for any applications other than general electronic equipment mentioned above, make sure to contact our company in advance. Note that the important requirements mentioned in this section are not applicable to cases where operation requirements such as application conditions are confirmed by our company in writing after consultation with your company.

6. We are making our continuous effort to improve the quality and reliability of our products, but semiconductor products are likely to fail with certain probability. In order to prevent any injury to persons or damages to property resulting from such failure, customers should be careful enough to incorporate safety measures in their design, such as redundancy feature, fire containment feature and fail-safe feature. We do not assume any liability or responsibility for any loss or damage arising from misuse or inappropriate use of the products.
7. The products have been designed and tested to function within controlled environmental conditions. Do not use products under conditions that deviate from methods or applications specified in this datasheet. Failure to employ the products in the proper applications can lead to deterioration, destruction or failure of the products. We shall not be responsible for any bodily injury, fires or accident, property damage or any consequential damages resulting from misuse or misapplication of the products.
8. **Quality Warranty**
 - 8-1. **Quality Warranty Period**

In the case of a product purchased through an authorized distributor or directly from us, the warranty period for this product shall be one (1) year after delivery to your company. For defective products that occurred during this period, we will take the quality warranty measures described in section 8-2. However, if there is an agreement on the warranty period in the basic transaction agreement, quality assurance agreement, delivery specifications, etc., it shall be followed.
 - 8-2. **Quality Warranty Remedies**

When it has been proved defective due to manufacturing factors as a result of defect analysis by us, we will either deliver a substitute for the defective product or refund the purchase price of the defective product.

Note that such delivery or refund is sole and exclusive remedies to your company for the defective product.
 - 8-3. **Remedies after Quality Warranty Period**

With respect to any defect of this product found after the quality warranty period, the defect will be analyzed by us. On the basis of the defect analysis results, the scope and amounts of damage shall be determined by mutual agreement of both parties. Then we will deal with upper limit in Section 8-2. This provision is not intended to limit any legal rights of your company.
9. Anti-radiation design is not implemented in the products described in this document.
10. The X-ray exposure can influence functions and characteristics of the products. Confirm the product functions and characteristics in the evaluation stage.
11. WLCSP products should be used in light shielded environments. The light exposure can influence functions and characteristics of the products under operation or storage.
12. Warning for handling Gallium and Arsenic (GaAs) products (Applying to GaAs MMIC, Photo Reflector). These products use Gallium (Ga) and Arsenic (As) which are specified as poisonous chemicals by law. For the prevention of a hazard, do not burn, destroy, or process chemically to make them as gas or power. When the product is disposed of, please follow the related regulation and do not mix this with general industrial waste or household waste.
13. Please contact our sales representatives should you have any questions or comments concerning the products or the technical information.



Nisshinbo Micro Devices Inc.

Official website

<https://www.nisshinbo-microdevices.co.jp/en/>

Purchase information

<https://www.nisshinbo-microdevices.co.jp/en/buy/>