

One-cell Li-ion Battery Protection IC with High-accuracy Overcurrent Detection and Selectable RESET Function

NO.EA-525-221115

OVERVIEW

The R5613L is a one-cell Li-ion / polymer battery protection IC providing overcharge, overdischarge and charge-/discharge-overcurrent detections. Major features of this device include charge-/discharge-overcurrent detectors with high-accuracy of ± 1.0 mV and the RST pin function which can switch for an external MOSFET to either a RESET or a forced-standby state.

KEY BENEFITS

- Lower-resistance of Sense Resistor by Overcurrent Detector with Lower-voltage and High-accuracy: Achieving Heat Reduction on Board
- Low Consumption Current and Low Standby Current: Achieving Longer Driving Time with A Battery of Small Capacity
- Switching to RESET or Forced-standby State by RST Pin: Allowed External Control of Load

KEY SPECIFICATIONS

- Supply Current
 - Normal Mode: Typ. 2.5 μ A / Max. 4.8 μ A
(Only when selected 0 V Battery Charging "Inhibition" and Discharge Overcurrent Detection with Two-level),
Typ. 2.0 μ A / Max. 4.0 μ A
(Except for the above selection)
 - Standby Mode: Max.0.2 μ A (V_{DET2} : Auto Release type)
Max.0.04 μ A (V_{DET2} : Latch type)
- Detector Selectable Range and Accuracy
 - Overcharge detection voltage (V_{DET1}): 4.2 V to 4.7 V, ± 20 mV,
 - Overdischarge detection voltage (V_{DET2}): 2.1 V to 3.2 V, ± 35 mV
 - Discharge overcurrent detection voltage1 (V_{DET31}):
0.0070 V to 0.0300 V, ± 1 mV
 - Discharge overcurrent detection voltage2 (V_{DET32}):
0.011 V to 0.060 V, ± 2 mV
 - Charge overcurrent detection voltage (V_{DET4}):
-0.0070 V to -0.0300 V, ± 1 mV
 - Short-circuit detection voltage (V_{SHORT1}):
0.030 V $\leq V_{SHORT1} \leq 0.120$ V, ± 4 mV
0.120 V $< V_{SHORT1} \leq 0.200$ V, ± 5 mV
- RST Pin Function type selectable: RESET / Forced-standby type
- 0 V Battery Charging: Permission / Inhibition
0 V Charge Inhibition Voltage: 1.000 / 1.200 / 1.500 / 2.200 / 2.350 V
- Overcharge / Overdischarge Release Voltage Type selectable:
Auto Release / Latch
- Discharge Overcurrent Release Voltage Type selectable:
Auto Release1 ($V_- = V_{DD} \times 0.8$ V) / Auto Release2 ($V_- = 0.1$ V) / Latch
- Discharge Overcurrent Detection having two-level voltage detection (V_{DET31}/V_{DET32}) selectable: Enable / Disable

TYPICAL APPLICATION CIRCUIT

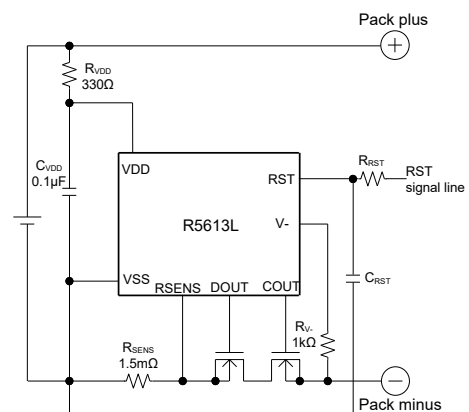

PACKAGE

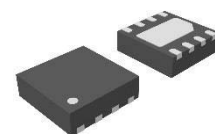

DFN1616-8B

1.6 mm x 1.6 mm x 0.4 mm

APPLICATIONS

- Smart Phone, Tablet PC
- Game, Hearing Aid

SELECTION GUIDE

Set Output Voltages, Delay Times, and Optional Functions are user-selectable.

Selection Guide

Product Name	Package	Quantity per Reel	Pb Free	Halogen Free
R5613Lxxx\$*-TR	DFN1616-8B	5,000 pcs	Yes	Yes

xxx: Specify a code that combines the following set output voltages. Refer to *Product Code List* for details.

Overcharge Detection Voltage (V_{DET1}): 4.2 V to 4.7 V in 5 mV step
 Overcharge Release Voltage (V_{REL1}): 4.0 V to 4.5 V in 5 mV step
 Overdischarge Detection Voltage (V_{DET2}) ⁽¹⁾: 2.1 V to 3.2 V in 50 mV step
 Overdischarge Release Voltage (V_{REL2}): 2.3 V to 3.2 V in 50 mV step
 Discharge Overcurrent Detection Voltage 1 (V_{DET31}) ⁽²⁾: 0.0070 V to 0.0300 V in 0.5 mV step
 Discharge Overcurrent Detection Voltage 2 (V_{DET32}) ⁽²⁾: 0.011 V to 0.060 V in 0.5 mV step
 Short-Circuit Detection Voltage (V_{SHORT1}) ⁽²⁾: 0.030 V to 0.200 V in 0.5 mV step
 Charge Overcurrent Detection Voltage (V_{DET4}): -0.0070 V to -0.0300 V in 0.5mV step
 0 V Charge Inhibition Voltage (V_{NOCHG}): 1.000 V / 1.200 V / 1.500 V / 2.200 V / 2.350 V
 RST Pin Function Detection Voltage (V_{RDET}): 0.800 V / 1.200 V

\$: Specify a code that combines the following delay times. Refer to *Delay Time Code Table* for details.

Overcharge Detection / Release Delay Time (t_{VDET1} / t_{VREL1})
 Overdischarge Detection / Release Delay Time (t_{VDET2} / t_{VREL2})
 Discharge Overcurrent Delay Time1/2 (t_{VDET31} / t_{VDET32})
 Discharge Overcurrent Release Delay Time (t_{VREL3})
 Charge Overcurrent Detection / Release Delay Time (t_{VDET4} / t_{VREL4})
 Reset Detection / Release Delay Time (t_{RST} / t_{RREL})

Delay Time Code Table

Code	t_{VDET1} [ms]	t_{VREL1} [ms]	t_{VDET2} [ms]	t_{VREL2} [ms]	t_{VDET31} [ms]	t_{VDET32} [ms]	t_{VREL3} [ms]	t_{VDET4} [ms]	t_{VREL4} [ms]	t_{SHORT} [ms]	t_{RST} [ms]	t_{RREL} [ms]
A	1024	1.2	64	1.2	3584	16	8.5	17	4	0.28	50	32
D	1024	16	32	1.2	4096	12	8.5	17	4	0.28	50	48
E	1024	16	20	1.2	12	-	8.5	17	4	0.28	50	32
F	1024	16	20	1.2	5120	12	8.5	17	4	0.28	50	48
G	1024	16	128	1.2	16	-	8.5	9	4	0.28	50	32

⁽¹⁾ In the case of 0 V Charging Prohibition (R5613LxxxxD/E/G), set the set output voltage of V_{DET2} to meet $V_{DET2} > V_{NOCHG}$ in consideration of their output voltage accuracy.

⁽²⁾ When selecting each set output voltage of V_{DET31} , V_{DET32} and V_{SHORT1} , keep from overlapping among them in consideration of their output voltage accuracy. Especially, V_{SHORT1} should be higher than 7.5 mV from V_{DET31} and V_{DET32} .

*: Specify a code that combines the following functions. Refer to *Function Code Table* for details.

Function Code Table

Code	RST Pin Function	RST Pin Function Detection Voltage (V_{RDET})	Overcharge Release	Overdischarge Release	Discharge Overcurrent		0 V Battery Charging	0 V Battery Charging Inhibition Voltage (V_{NOCHG})
					Release	Detection (V_{DET32})		
A	RESET	1.200 V	Auto Release	Auto Release	Auto Release1	Available	Permission	—
C	RESET	1.200 V	Auto Release	Auto Release	Auto Release1	Unavailable	Permission	—
D	RESET	1.200 V	Auto Release	Auto Release	Auto Release1	Unavailable	Inhibition	1.000 V to 2.200 V
E	Forced-standby	0.800 V	Latch	Latch	Auto Release2	Available	Inhibition	1.000 V to 2.200 V
G	Forced-standby	0.800 V	Latch	Latch	Latch	Unavailable	Inhibition	2.350 V
J	Forced-standby	0.800 V	Latch	Latch	Latch	Unavailable	Inhibition	1.500 V

Product Code List

Product Code Table

Product Name	Set Voltage [V]								
	V _{DET1}	V _{REL1}	V _{DET2}	V _{REL2}	V _{DET31}	V _{DET32}	V _{SHORT1}	V _{DET4}	V _{NOCHG}
R5613L101AA	4.445	4.295	2.350	2.550	0.0105	0.0150	0.0400	-0.0150	—
R5613L106AA	4.475	4.325	2.350	2.550	0.0105	0.0150	0.0400	-0.0150	—
R5613L108AA	4.445	4.295	2.350	2.550	0.0150	0.0195	0.0420	-0.0150	—
R5613L112AA	4.475	4.325	2.350	2.550	0.0150	0.0200	0.0560	-0.0190	—
R5613L102DE	4.280	—	2.900	—	0.0100	0.0150	0.0500	-0.0100	2.200
R5613L111DE	4.275	—	2.900	—	0.0300	0.0180	0.1750	-0.0130	2.200
R5613L116DE	4.250	—	2.600	—	0.0300	0.0120	0.0500	-0.0070	1.500
R5613L103EC	4.445	4.295	2.350	2.550	0.0105	—	0.0400	-0.0150	—
R5613L114EC	4.275	4.075	2.300	2.500	0.0175	—	0.0840	-0.0150	—
R5613L104ED	4.445	4.295	2.350	2.550	0.0105	—	0.0400	-0.0150	1.200
R5613L110ED	4.280	4.240	2.300	2.500	0.0200	—	0.0600	-0.0200	1.200
R5613L102FE	4.280	—	2.900	—	0.0100	0.0150	0.0500	-0.0100	2.200
R5613L107GG	4.450	—	3.200	—	0.0150	—	0.0400	-0.0150	2.350
R5613L109GG	4.285	—	2.750	—	0.0100	—	0.1000	-0.0100	2.350
R5613L113GG	4.240	—	3.100	—	0.0225	—	0.0300	-0.0160	2.350
R5613L115GG	4.375	—	2.750	—	0.0220	—	0.0500	-0.0160	2.350
R5613L117GG	4.480	—	2.750	—	0.0300	—	0.0700	-0.0225	2.350
R5613L119GG	4.450	—	3.100	—	0.0200	—	0.0400	-0.0150	2.350
R5613L120GJ	4.450	—	3.100	—	0.0200	—	0.0400	-0.0150	1.500

Please contact our sales representatives if required a combination of delay time and function codes other than the above combinations: AA, DE, EC, ED, FE, GG, and GJ.

BLOCK DIAGRAMS

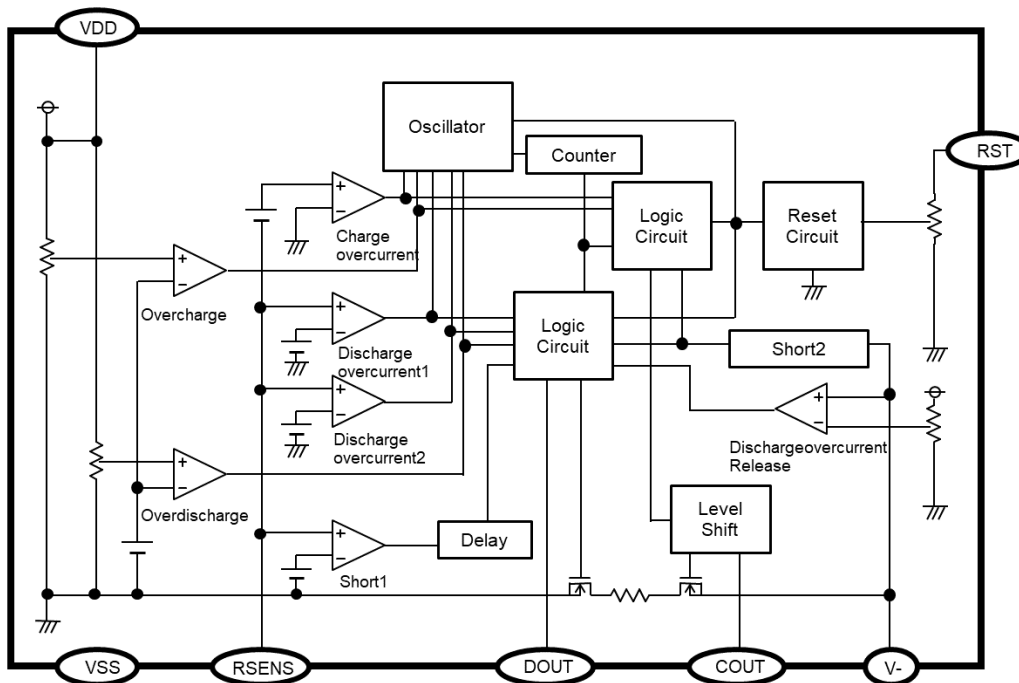

R5613L (RESET type) Block Diagram

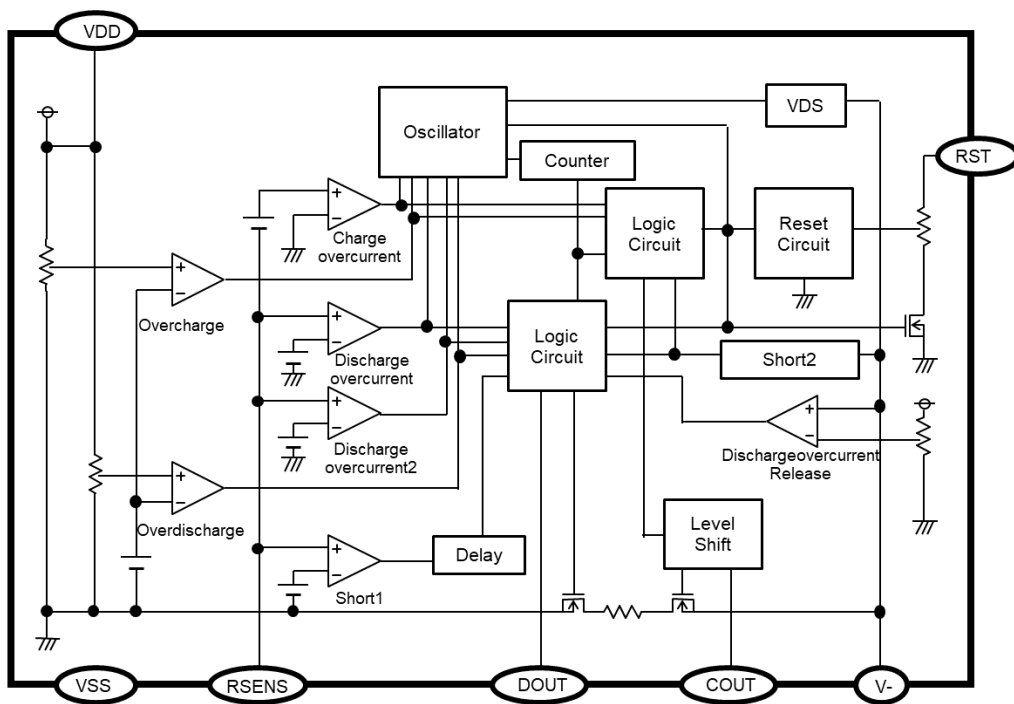

R5613L (Forced-standby type) Block Diagram

PIN DESCRIPTION

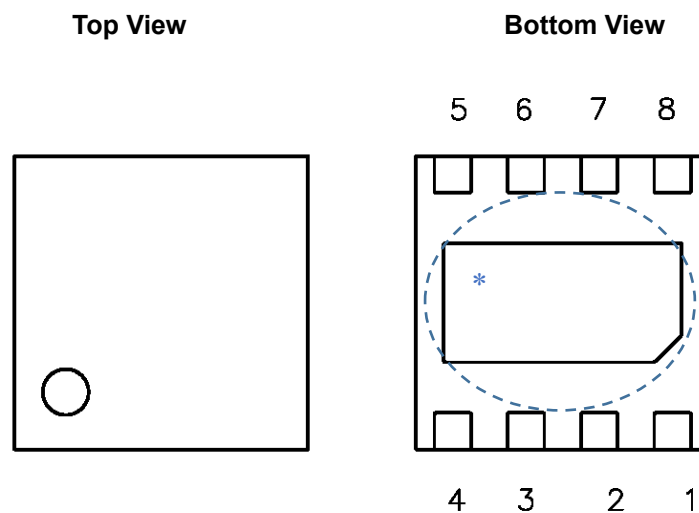

R5613L (DFN1616-8B) Pin Configuration

R5613L Pin Description

Pin No	Symbol	Pin Description
1	RST	RESET / Forced-Standby state input pin
2	V-	Charge negative input pin
3	COUT	Charge detection output pin, CMOS output
4	DOUT	Discharge detection output pin, CMOS output
5	VSS	Ground pin for the IC
6	VDD	Power supply pin, the substrate level of the IC
7	RSENS	Overcurrent detection input pin
8	NC	No connection

* The tab on the bottom of the package is substrate level (V_{DD}). It is recommended that the tab be connected to the VDD pin on the board, or otherwise be left floating.

ABSOLUTE MAXIMUM RATINGS(Ta = 25°C, V_{SS} = 0V)

Symbol	Item	Rating	Unit
V _{DD}	Supply voltage	-0.3 to 12	V
V-	V- pin input voltage	V _{DD} -30 to V _{DD} +0.3	V
V _{RSENS}	RSENS pin input voltage	V _{SS} -0.3 to V _{DD} +0.3	V
V _{RST}	RST pin input voltage	V _{SS} -0.3 to V _{DD} +0.3	V
V _{COUT}	COUT pin output voltage	V _{DD} -30 to V _{DD} +0.3	V
V _{DOUT}	DOUT pin output voltage	V _{SS} -0.3 to V _{DD} +0.3	V
P _D	Power Dissipation	Refer to Appendix "Power Dissipation"	
T _j	Junction Temperature Range	-40 to 125	°C
T _{stg}	Storage Temperature Range	-55 to 125	°C

ABSOLUTE MAXIMUM RATINGS

Electronic and mechanical stress momentarily exceeded absolute maximum ratings may cause permanent damage and may degrade the lifetime and safety for both device and system using the device in the field. The functional operations at or over these absolute maximum ratings are not assured.

RECOMMENDED OPERATING CONDITION

Symbol	Item	Rating	Unit
V _{DD}	Operating Input Voltage	1.5 to 5.0	V
T _a	Operating Temperature Range	-40 to 85	°C

RECOMMENDED OPERATING CONDITIONS

All of electronic equipment should be designed that the mounted semiconductor devices operate within the recommended operating conditions. The semiconductor devices cannot operate normally over the recommended operating conditions, even if they are used over such conditions by momentary electronic noise or surge. And the semiconductor devices may receive serious damage when they continue to operate over the recommended operating conditions.

ELECTRICAL CHARACTERISTICS

R5613LxxxXX Electrical Characteristics

(Ta = 25°C)

Symbol	Parameter	Conditions	Min.	Typ.	Max.	Unit	Circuit (1)	
V _{DD1}	Operating input voltage	V _{DD} -V _{SS}	1.5		5.0	V	A	
V _{STCHG}	Minimum charging voltage for 0 V battery charger (2)	V _{DD} -V ₋ , V _{DD} -V _{SS} = 0V			1.8	V	A	
V _{NOCHG}	0 V battery charging inhibition voltage (3)	V _{DD} -V _{SS} V _{DD} -V ₋ = 4V	V _{NOCHG} ≤ 1.500V	V _{NOCHG} -0.25	V _{NOCHG}	V _{NOCHG} +0.25	V	A
			V _{NOCHG} = 2.200V	2.000	2.200	2.500		
			V _{NOCHG} = 2.350V	2.050	2.350	2.550		
V _{DET1}	Overcharge detection voltage	R _{VDD} = 330Ω	V _{DET1} -0.020	V _{DET1}	V _{DET1} +0.020	V	B	
V _{REL1}	Overcharge release voltage	R _{VDD} = 330Ω	V _{REL1} -0.045	V _{REL1}	V _{REL1} +0.045	V	B	
t _{VDET1}	Overcharge detection delay time	V _{DD} = 3.6V → V _{DET1} +0.1V	t _{VDET1} × 0.75	t _{VDET1}	t _{VDET1} × 1.30	s	C	
t _{VREL1}	Overcharge release delay time	V _{DD} = 4.8V → V _{REL1} -0.1V	t _{VREL1} = 1.2ms	0.7	1.2	2.5	ms	C
			t _{VREL1} = 16ms	11.2	16	20.8		
V _{DET2}	Overdischarge detection voltage	Detect falling edge of supply voltage	V _{DET2} -0.035	V _{DET2}	V _{DET2} +0.035	V	D	
V _{REL2}	Overdischarge release voltage	Detect rising edge of supply voltage	V _{REL2} -0.055	V _{REL2}	V _{REL2} +0.095	V	E	
t _{VDET2}	Overdischarge detection delay time	V _{DD} = V _{DET2} +0.15V → V _{DET2} -0.1V	t _{VDET2} × 0.75	t _{VDET2}	t _{VDET2} × 1.30	ms	D	
t _{VREL2}	Overdischarge release delay time	V _{DD} = V _{DET2} -0.2V → V _{REL2} +0.25 V	0.9	1.2	1.7	ms	E	
V _{CHGDET}	Charger connection detection voltage	V _{DD} = V _{DET2} +0.020V, V _{RSSENS} = 0V	0.500	0.800	1.100	V	A	
V _{DET31}	Discharge overcurrent detection voltage 1	V _{DD} = 3.6V, V ₋ = V _{RSSENS}	V _{DET31} -0.0010	V _{DET31}	V _{DET31} +0.0010	V	F	
t _{VDET31}	Discharge overcurrent 1 detection delay time	V _{DD} = 3.6V, V _{RSSENS} = 0V → V _{DET31} +0.005V V ₋ = V _{RSSENS}	t _{VDET31} × 0.75	t _{VDET31}	t _{VDET31} × 1.30	ms	F	
V _{DET32}	Discharge overcurrent detection voltage 2	V _{DD} = 3.6V, V ₋ = V _{RSSENS}	V _{DET32} -0.002	V _{DET32}	V _{DET32} +0.002	V	F	
t _{VDET32}	Discharge overcurrent 2 detection delay time	V _{DD} = 3.6V, V _{RSSENS} = 0V → V _{DET32} +0.005V V ₋ = V _{RSSENS}	t _{VDET32} × 0.75	t _{VDET32}	t _{VDET32} × 1.30	ms	F	

(1) Refer to TEST CIRCUITS for detail information.

(2) 0 V battery charging permission supported product only

(3) 0 V battery charging inhibition supported product only

R5613LxxxXX Electrical Characteristics (Continued)

(Ta = 25°C)

Symbol	Items	Conditions		Min.	Typ.	Max.	Unit	Circuit (1)
V _{SHORT1}	Short detection voltage 1	Detect rising edge of RSENS pin voltage, V _{DD} = 3.6V, V _{RSENS} = V-	0.030V ≤ V _{SHORT1} ≤ 0.120V	V _{SHORT1} -0.004	V _{SHORT1}	V _{SHORT1} +0.004	V	F
			0.120V < V _{SHORT1} ≤ 0.200V	V _{SHORT1} -0.005		V _{SHORT1} +0.005		
t _{SHORT}	Short detection delay time (2)	V _{DD} = 3.6V, V _{RSENS} = 0V → 1V, V- = V _{RSENS}		210	280	380	μs	F
V _{SHORT2}	Short detection voltage 2	Detect rising edge of V- pin voltage, V _{DD} = 3.6V, V _{RSENS} = 0V		V _{DD} ×0.850 -0.050	V _{DD} ×0.850	V _{DD} ×0.850 +0.050	V	F
V _{REL3}	Discharge overcurrent release voltage	V _{DD} = 3.6V, V _{RSENS} = 0V	Auto Release1	V _{DD} ×0.800 -0.050	V _{DD} ×0.800	V _{DD} ×0.800 +0.050	V	F
			Auto Release2	0.010	0.100	0.250		
			Latch	V _{DD} ×0.780 -0.100	V _{DD} ×0.780	V _{DD} ×0.780 +0.100		
R _{SHORT}	Discharge overcurrent release resistance	Auto Release1: 3.2 ≤ V _{DD} ≤ 4.4V, V- = 2.93V		6.5	10.0	13.5	kΩ	F
		Auto Release2: V _{DD} = 3.6V, V- = 0.2V		20	45	70		
t _{REL3}	Discharge overcurrent release delay time	V _{DD} = 3.6V, V- = 3.6V → 0V, V _{RSENS} = 0V		6.3	8.5	11.1	ms	F
V _{DET4}	Charge overcurrent detection voltage	V _{DD} = 3.6V, V- = V _{RSENS}		V _{DET4} -0.0010	V _{DET4}	V _{DET4} +0.0010	V	G
t _{DET4}	Charge overcurrent detection delay time	V _{DD} = 3.6V, V _{RSENS} = 0V → -0.5V, V- = V _{RSENS}		t _{DET4} ×0.75	t _{DET4}	t _{DET4} ×1.30	ms	G
V _{REL4}	Charge overcurrent release voltage	V _{DD} = 3.6V, V _{RSENS} = 0V		0.010	0.100	0.250	V	G
t _{REL4}	Charge overcurrent release delay time	V _{DD} = 3.6V, V- = -0.5V → 1V, V- = V _{RSENS}		3.0	4	5.2	ms	G
V _{RDET}	RST pin function detection voltage	Detect rising edge of RST pin voltage, V _{DD} = 3.6V, V- = V _{RSENS} = 0V		V _{RDET} -0.3	V _{RDET}	V _{RDET} +0.3	V	M
V _{RREL}	RST pin function release voltage	V _{DD} = 3.6V, V _{RSENS} = 0V	RESET: Detect rising edge of V- pin voltage	0.500	0.800	1.100	V	N
			Forced Standby: Detect falling edge of V- pin voltage					

(1) Refer to TEST CIRCUITS for detail information.

(2) Short release delay time 1 is the same value as t_{REL3}.

R5613LxxxXX Electrical Characteristics (Continued)

(Ta = 25°C)

Symbol	Items	Conditions	Min.	Typ.	Max.	Unit	Circuit (1)
I _{RST}	RST pin input current, "High"	V _{DD} = 3.6V, R _{ST} = 3.6V, V ₋ = V _{RSENS} = 0V			1.2	μA	M
R _{RST}	RST pin input resistance	V _{DD} = 3.6V, R _{ST} = 3.6V, V ₋ = V _{RSENS} = 0V	3.0			MΩ	M
t _{RST}	RST pin function detection delay time	V _{DD} = 3.6V, R _{ST} = 0V → 3.6V, V ₋ = V _{RSENS} = 0V	35	50	65	ms	M
t _{RREL}	RST pin function release delay time	V _{DD} =3.6V, V _{RSENS} =0V	t _{RREL} ×0.70	t _{RREL}	t _{RREL} ×1.30	ms	N
		RESET: R _{ST} = 3.6V→0V, V ₋ = 0V					
		Forced Standby: V ₋ = 3.6V→0V, R _{ST} = 0V					
V _{OL1}	COUT pin NMOS ON voltage	I _{OL} = 50μA, V _{DD} = 4.55V		0.4	0.5	V	H
V _{OH1}	COUT pin PMOS ON voltage	I _{OH} = -50μA, V _{DD} = 3.9V	3.4	3.7		V	I
V _{OL2}	DOUT pin NMOS ON voltage	I _{OL} = 50μA, V _{DD} = 1.9V		0.2	0.5	V	J
V _{OH2}	COUT pin PMOS ON voltage	I _{OH} = -50μA, V _{DD} = 3.9V	3.4	3.7		V	K
I _{DD}	Supply current	V _{DD} =3.9V, V ₋ = 0V		2.5	4.8	μA	L
		Support for the 0 V battery charging "Inhibition" and the discharge overcurrent detection with two levels.					
		Except for the above support		2.0	4.0		
I _{STANDBY}	Standby current	V _{DD} =1.9V			0.2	μA	L
		V _{DET2} : Auto Release					
		V _{DET2} : Latch			0.04		

(1) Refer to TEST CIRCUITS for detail information.

The specifications are guaranteed by design engineering at $-20^{\circ}\text{C} \leq T_a \leq 60^{\circ}\text{C}$.

R5613LxxxXX Electrical Characteristics
($-20^{\circ}\text{C} \leq T_a \leq 60^{\circ}\text{C}$)

Symbol	Parameter	Conditions	Min.	Typ.	Max.	Unit	Circuit (1)	
V_{DD1}	Operating input voltage	$V_{DD}-V_{SS}$	1.5		5.0	V	A	
V_{STCHG}	Minimum charging voltage for 0 V battery charger (2)	$V_{DD}-V_{-}$, $V_{DD}-V_{SS} = 0\text{V}$			1.8	V	A	
V_{NOCHG}	0 V battery charging inhibition voltage (3)	$V_{DD}-V_{SS}$, $V_{DD}-V_{-} = 4\text{V}$	$V_{NOCHG} \leq 1.500\text{V}$	V_{NOCHG}	V_{NOCHG}	V_{NOCHG}	V	A
			$V_{NOCHG} = 2.200\text{V}$	1.900	2.200	2.600		
			$V_{NOCHG} = 2.350\text{V}$	2.000	2.350	2.650		
V_{DET1}	Overcharge detection voltage	$R_{VDD} = 330\Omega$	V_{DET1} -0.025	V_{DET1}	V_{DET1} +0.025	V	B	
V_{REL1}	Overcharge release voltage	$R_{VDD} = 330\Omega$	V_{REL1} -0.055	V_{REL1}	V_{REL1} +0.055	V	B	
t_{VDET1}	Overcharge detection delay time	$V_{DD} = 3.6\text{V} \rightarrow V_{DET1}+0.1\text{V}$	t_{VDET1} $\times 0.70$	t_{VDET1}	t_{VDET1} $\times 1.40$	s	C	
t_{VREL1}	Overcharge release delay time	$V_{DD} = 4.8\text{V} \rightarrow$ $V_{REL1}-0.1\text{V}$	$t_{VREL1} = 1.2\text{ms}$	0.5	1.2	3.0	ms	C
			$t_{VREL1} = 16\text{ms}$	8	16	40		
V_{DET2}	Overdischarge detection voltage	Detect falling edge of supply voltage	V_{DET2} -0.055	V_{DET2}	V_{DET2} +0.055	V	D	
V_{REL2}	Overdischarge release voltage	Detect rising edge of supply voltage	V_{REL2} -0.065	V_{REL2}	V_{REL2} +0.105	V	E	
t_{VDET2}	Overdischarge detection delay time	$V_{DD} = V_{DET2}+0.15\text{V}$ $\rightarrow V_{DET2}-0.1\text{V}$	t_{VDET2} $\times 0.70$	t_{VDET2}	t_{VDET2} $\times 1.40$	ms	D	
t_{VREL2}	Overdischarge release delay time	$V_{DD} = V_{DET2}-0.2\text{V}$ $\rightarrow V_{REL2}+0.25\text{V}$	0.84	1.20	2.00	ms	E	
V_{CHGDET}	Charger Connection Detection Voltage	$V_{DD} = V_{DET2}+0.020\text{V}$, $V_{RSENS} = 0\text{V}$	0.400	0.800	1.200	V	A	
V_{DET31}	Discharge overcurrent detection voltage 1	$V_{DD} = 3.6\text{V}$, $V_{-} = V_{RSENS}$	V_{DET31} -0.0015	V_{DET31}	V_{DET31} +0.0015	V	F	
t_{VDET31}	Discharge overcurrent 1 detection delay time	$V_{DD} = 3.6\text{V}$, $V_{RSENS}=0\text{V} \rightarrow V_{DET31}+0.005\text{V}$ $V_{-} = V_{RSENS}$	t_{VDET31} $\times 0.75$	t_{VDET31}	t_{VDET31} $\times 1.35$	ms	F	
V_{DET32}	Discharge overcurrent detection voltage 2	$V_{DD} = 3.6\text{V}$, $V_{-} = V_{RSENS}$	V_{DET32} -0.0025	V_{DET32}	V_{DET32} +0.0025	V	F	
t_{VDET32}	Discharge overcurrent 2 detection delay time	$V_{DD} = 3.6\text{V}$, $V_{RSENS} = 0\text{V} \rightarrow V_{DET32}+0.005\text{V}$ $V_{-} = V_{RSENS}$	t_{VDET32} $\times 0.70$	t_{VDET32}	t_{VDET32} $\times 1.40$	ms	F	

(1) Refer to *TEST CIRCUITS* for detail information.

(2) 0 V battery charging permission supported product only

(3) 0 V battery charging inhibition supported product only

R5613LxxxXX Electrical Characteristics (Continued) (-20°C ≤ Ta ≤ 60°C)

Symbol	Items	Conditions		Min.	Typ.	Max.	Unit	Circuit (1)
V _{SHORT1}	Short detection voltage 1	Detect rising edge of RSENS pin voltage, V _{DD} = 3.6V, V _{RSENS} = V-	0.030V ≤ V _{SHORT1} ≤ 0.120V	V _{SHORT1} -0.005	V _{SHORT1}	V _{SHORT1} +0.005	V	F
			0.120V < V _{SHORT1} ≤ 0.200V	V _{SHORT1} -0.008		V _{SHORT1} +0.008		
t _{SHORT}	Short detection delay time (2)	V _{DD} =3.6V, V _{RSENS} = 0V → 1V V- = V _{RSENS}		175	280	420	μs	F
V _{SHORT2}	Short detection voltage 2	Detect rising edge of V- pin voltage, V _{DD} = 3.6V, V _{RSENS} = 0V		V _{DD} ×0.850 -0.100	V _{DD} ×0.850	V _{DD} ×0.850 +0.100	V	F
V _{REL3}	Discharge overcurrent release voltage	V _{DD} = 3.6V, V _{RSENS} = 0V	Auto Release1	V _{DD} ×0.800 -0.100	V _{DD} ×0.800	V _{DD} ×0.800 +0.100	V	F
			Auto Release2	0.000	0.100	0.300		
			Latch	V _{DD} ×0.780 -0.200	V _{DD} ×0.780	V _{DD} ×0.780 +0.200		
R _{SHORT}	Discharge overcurrent release resistance	Auto Release1: 3.2 ≤ V _{DD} ≤ 4.4V, V- = 2.93V		5.5	10.0	14.5	kΩ	F
		Auto Release2: V _{DD} = 3.6V, V- = 0.2V		17.1	45.0	71.0		
t _{REL3}	Discharge overcurrent release delay time	V _{DD} = 3.6V, V- = 3.6V → 0V V _{RSENS} = 0 V		5.95	8.5	12.0	ms	F
V _{DET4}	Charge overcurrent detection voltage	V _{DD} = 3.6 V, V- = V _{RSENS}		V _{DET4} -0.0015	V _{DET4}	V _{DET4} +0.0015	V	G
t _{DET4}	Charge overcurrent detection delay time	V _{DD} = 3.6 V, V _{RSENS} = 0V → -0.5V, V- = V _{RSENS}		t _{DET4} ×0.70	t _{DET4}	t _{DET4} ×1.40	ms	G
V _{REL4}	Charge overcurrent release voltage	V _{DD} = 3.6V, V _{RSENS} = 0V		0.000	0.100	0.300	V	G
t _{REL4}	Charge overcurrent release delay time	V _{DD} = 3.6V, V- = -0.5V → 1V, V- = V _{RSENS}		2.8	4	5.6	ms	G
V _{RDET}	RST pin function detection voltage	Detect rising edge of RST pin voltage, V _{DD} = 3.6V, V- = V _{RSENS} = 0V		V _{RDET} -0.5	V _{RDET}	V _{RDET} +0.5	V	M
V _{RREL}	RST pin function release voltage	V _{DD} =3.6V, V _{RSENS} =0V	RESET: Detect rising edge of V- pin voltage	0.400	0.800	1.200	V	N
			Forced Standby: Detect falling edge of V- pin voltage					

(1) Refer to TEST CIRCUITS for detail information.

(2) Short release delay time 1 is the same value as t_{REL3}.

R5613LxxxXX Electrical Characteristics (Continued)

(-20°C ≤ Ta ≤ 60°C)

Symbol	Items	Conditions	Min.	Typ.	Max.	Unit	Circuit (1)
I _{RST}	RST pin input current, "High"	V _{DD} = 3.6V, R _{ST} = 3.6V, V ₋ = V _{RSENS} = 0V			3.6	μA	M
R _{RST}	RST pin input resistance	V _{DD} = 3.6V, R _{ST} = 3.6V, V ₋ = V _{RSENS} = 0V	1.0			MΩ	M
t _{RST}	RST pin function detection delay time	V _{DD} = 3.6V, R _{ST} = 0V → 3.6V, V ₋ = V _{RSENS} = 0V	25	50	75	ms	M
t _{RREL}	RST pin function release delay time	V _{DD} =3.6V, V _{RSENS} =0V RESET: R _{ST} = 3.6V→0V, V ₋ = 0V Forced Standby: V ₋ = 3.6V→0V, R _{ST} = 0V	t _{RREL} ×0.50	t _{RREL}	t _{RREL} ×1.50	ms	N
V _{OL1}	COUT pin NMOS ON voltage	I _{OL} = 50μA, V _{DD} = 4.55 V		0.4	0.5	V	H
V _{OH1}	COUT pin PMOS ON voltage	I _{OH} = -50μA, V _{DD} = 3.9 V	3.4	3.7		V	I
V _{OL2}	DOUT pin NMOS ON voltage	I _{OL} = 50μA, V _{DD} = 1.9 V		0.2	0.5	V	J
V _{OH2}	COUT pin PMOS ON voltage	I _{OH} = -50μA, V _{DD} = 3.9 V	3.4	3.7		V	K
I _{DD}	Supply current	V _{DD} =3.9V, V ₋ = 0V Support for the 0 V battery charging "Inhibition" and the discharge overcurrent detection with two levels. Except for the above support		2.5 2.0	6.0 5.0	μA	L
I _{STANDBY}	Standby current	V _{DET2} : Auto Release, V _{DD} =1.6V			0.3	μA	L
		V _{DET2} : Latch, V _{DD} =1.9V			0.1		

(1) Refer to TEST CIRCUITS for detail information.

Test Circuits

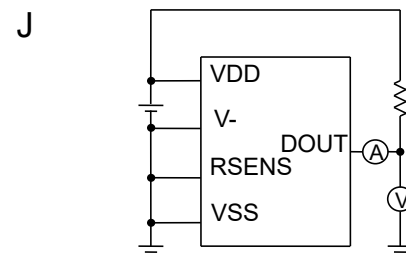
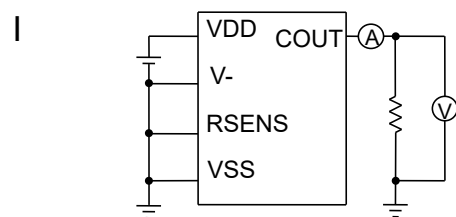
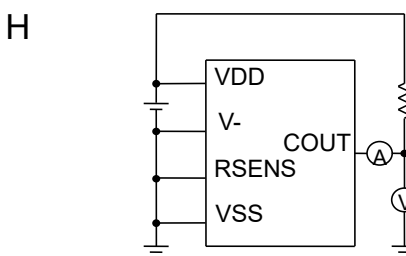
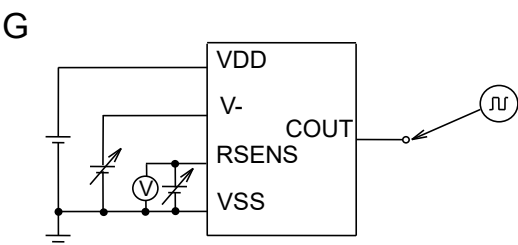
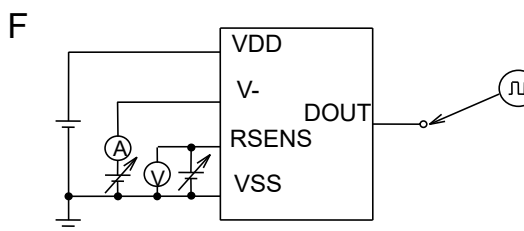
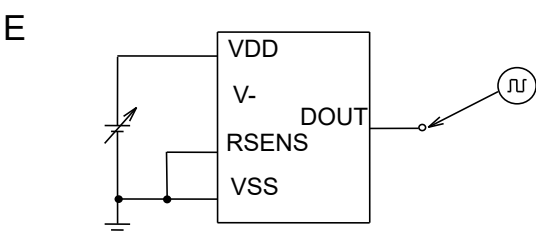
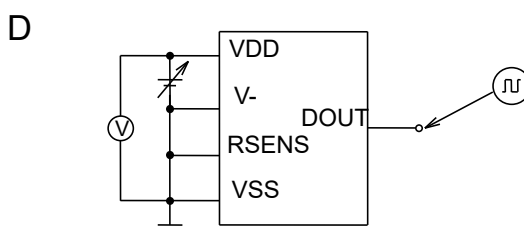
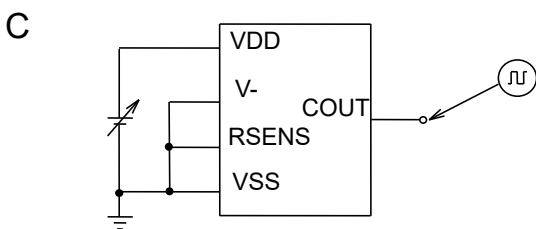
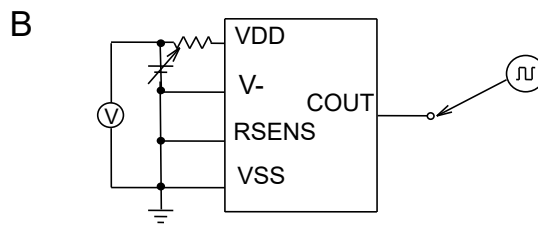
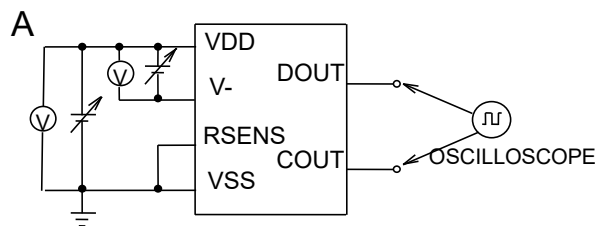

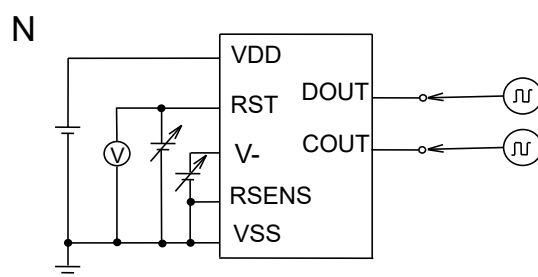
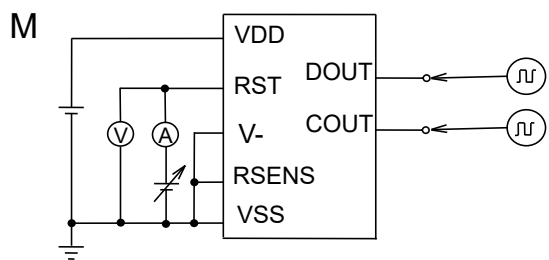
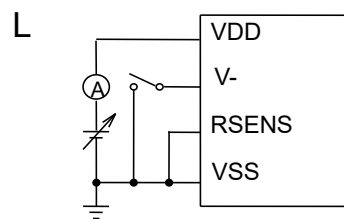
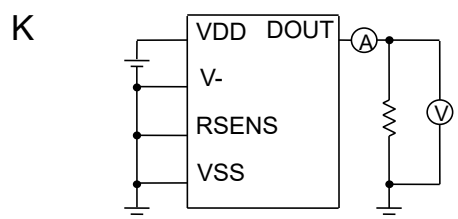

THEORY OF OPERATION

Overcharge Protection

When the overcharge detection delay time (t_{VDET1}) passes under the condition that the VDD pin voltage (V_{DD}) exceeds the overcharge detection voltage (V_{DET1}), this IC enters the overcharge state.

In this state, the COUT pin becomes Low and the charge control FET is turned off to stop charging. The V- pin voltage (V-) increases by the Vf voltage (Vf) of the internal parasitic diode than the VSS pin voltage (V_{SS}), because the discharge current flows via the parasitic diode even when the charge control FET is off.

A release from the overcharge state must meet the following pin conditions and delay time according to the selected release type.

Type	Pin Conditions	Delay Time
Auto Release	$V_- < V_{REL4}$ and $V_{DD} < V_{REL1}$ or $V_- > V_{REL4}$ and $V_{DD} < V_{DET1}$	t_{VREL1}
Latch	$V_- > V_{REL4}$ and $V_{DD} < V_{DET1}$	t_{VREL1}

Overdischarge Protection

When the overdischarge detection delay time (t_{VDET2}) passes under the condition that the VDD pin voltage (V_{DD}) falls below the overdischarge detection voltage (V_{DET2}), this IC enters the overdischarge state.

In this state, the DOUT pin becomes Low and the discharge control FET is turned off to stop discharging. The V- pin voltage (V-) decreases by the Vf voltage (Vf) of the internal parasitic diode than the VSS pin voltage (V_{SS}), because the charge current flows via the parasitic diode even when the discharge control FET is off.

In addition, when V- is pulled up to V_{DD} level and exceeds the charger detection voltage (V_{CHGDET}), the IC enters the standby state. It results in reducing the consumption current to a minimum.

A release from the overdischarge state must meet the following pin conditions and delay time according to the selected release type.

Type	Pin Conditions	Delay Time
Auto Release	$V_- > V_{CHGDET}$ and $V_{DD} > V_{REL2}$ or $V_- < V_{CHGDET}$ and $V_{DD} > V_{DET2}$	t_{VREL2}
Latch	$V_- < V_{CHGDET}$ and $V_{DD} > V_{DET2}$	t_{VREL2}

Discharge Overcurrent Protection

In order to monitor a discharge current, this IC measures a voltage difference of the sense resistor (R_{SENS}) connected between the RSENS and the VSS pins to detect the current value.

This IC has two levels of the discharge overcurrent detection voltage $1/2 (V_{\text{DET31}} / V_{\text{DET32}})$. When the discharge overcurrent detection delay time (t_{VDET31}) passes under the condition that the discharge current, which is converted through R_{SENS} for current-to-voltage conversion, exceeds V_{DET31} , this IC enters the discharge overcurrent state. In a case where V_{DET32} is enabled, this IC enters the discharge overcurrent state when the discharge overcurrent detection delay time (t_{VDET32}) passes under the condition exceeding V_{DET32} .

In this state, the DOUT pin becomes Low and the discharge control FET is turned off to shut off the discharge current.

A release from the discharge overcurrent state must meet the following pin condition and delay time according to the selected release type.

Type	Pin Condition	Delay Time	Remarks
Auto Release	$V_- < V_{\text{REL3}}$	t_{VREL3}	V_- is pulled down to the VSS level inside the IC. <small>Note1</small>
Latch	$V_- < V_{\text{REL3}}$	t_{VREL3}	V_- is pulled up to the VDD level inside the IC. <small>Note2</small>

Note1: It is possible to release the abnormal condition of the load connected to the battery pack. When the discharge overcurrent release delay time (t_{VREL3}) passes under the condition V_- falls below V_{REL3} , this IC releases from the discharge overcurrent state. V_- can be expressed by the following equation.

$$V_- = V_{\text{CELL}} \times R_{\text{SHORT}} / (R_{\text{SHORT}} + R_{V_-} + R_{\text{LOAD}})$$

V_{CELL} : Battery voltage

R_{SHORT} : Discharge overcurrent release resistance

R_{V_-} : External resistor for V_- pin

R_{LOAD} : Load resistance to a battery pack

Note2: When connecting a charger to pull V_- down, this IC releases from the discharge overcurrent state.

Short-circuit Current Protection

In order to monitor a short-circuit current, this IC measures a voltage difference of the sense resistor (R_{SENS}) connected between the RSENS and the VSS pins to detect the current value. When the short-circuit detection delay time (t_{SHORT}) passes under the condition that the short-circuit current, which is converted through R_{SENS} for current-to-voltage conversion, exceeds the short-circuit detection voltage (V_{SHORT}), this IC enters the short-circuit state.

In this state, the DOUT pin becomes Low and the discharge control FET is turned off to shut off the short-circuit current.

A release from the short-circuit state must meet the same condition and delay time as the discharge overcurrent protection.

Charge Overcurrent Protection

In order to monitor a charge current, this IC measures a voltage difference of the sense resistor (R_{SENS}) connected between the RSENS and the VSS pins to detect the current value. When the charge overcurrent detection delay time (t_{VDET4}) passes under the condition that the charge current, which is converted through RSENS for current-to-voltage conversion, falls below the charge overcurrent detection voltage (V_{DET4}), this IC enters the charge overcurrent state.

In this state, the COUT pin becomes Low and the charge control FET is turned off to shut off the charge current. A release from the charge overcurrent state must meet the following pin condition and delay time according to the selected release type.

Type	Pin Condition	Delay Time	Remarks
Auto Release	$V_- > V_{\text{REL4}}$	t_{VREL4}	V- is pulled up to the VDD level inside the IC. <small>Note</small>

Note: By disconnecting the charger, this IC releases from the charge overcurrent state.

RST Pin Function

The RST pin function has two types: RESET type and Forced-standby type.

RESET Type

The RST input pin supports a Pch open-drain output type and has an internal resistor (R_{RST}) to pull down to VSS.

When the RST pin function detection delay time (t_{RST}) passes under the condition of $V_{\text{RST}} > V_{\text{RDET}}$ (V_{RST} : the RST pin input voltage, V_{RDET} : the RST pin function detection voltage), this IC enters the RESET state.

After entering the RESET state, the IC turns off the charge and the discharge control FETs to shut off between the battery and the charger. Then protections for overcharge, overdischarge, discharge overcurrent, and short-circuit are stopped.

When the RST pin function release delay time (t_{RREL}) passes under the condition of $V_{\text{RST}} < V_{\text{RDET}}$ or $V_- > V_{\text{RREL}}$, this IC releases from the RESET state.

Forced-standby Type

On the Forced-standby type, a battery pack must not be connected with a charger when the RST pin function runs.

The RST input pin supports a CMOS output type and has an internal resistor (R_{RST}) to pull down to VSS.

When the RST pin function detection delay time (t_{RST}) passes under the condition of $V_{\text{RST}} > V_{\text{RDET}}$ (V_{RST} : the RST pin input voltage, V_{RDET} : the RST pin function detection voltage), the IC turns off the discharge control FET and pulls the V- pin up to VDD inside. Then protections for overcharge, overdischarge, discharge overcurrent, and short-circuit are stopped. After that, the IC enters the Forced-standby state when the V- pin voltage (V-) exceeds the RST pin function release voltage (V_{RREL}). It results in reducing the consumption current to a minimum. The RST pin becomes OPEN when an internal switch is turned off.

When the RST pin function release delay time (t_{RREL}) passes under the condition is transitioned from $V_- > V_{\text{RREL}}$ to $V_- < V_{\text{RREL}}$ by connecting the charger, this IC releases from the Forced-standby state. At the time of release, avoid meeting the detection condition ($V_{\text{RST}} > V_{\text{RDET}}$).

0 V Battery Charging

This IC has the selectable charging function for the battery discharged to 0 V.

0 V Battery Charge Function “Permission”

This function allows to charge to the 0 V battery by connecting the charger with the minimum charging voltage (V_{STCHG}) and more.

0 V Battery Charge Function “Inhibition”

This function inhibits to charge to the battery with the 0 V-battery charging inhibition voltage (V_{NOCHG}) or less even if connecting the charger.

Timing Charts

Overcharge voltage and Overcharge current

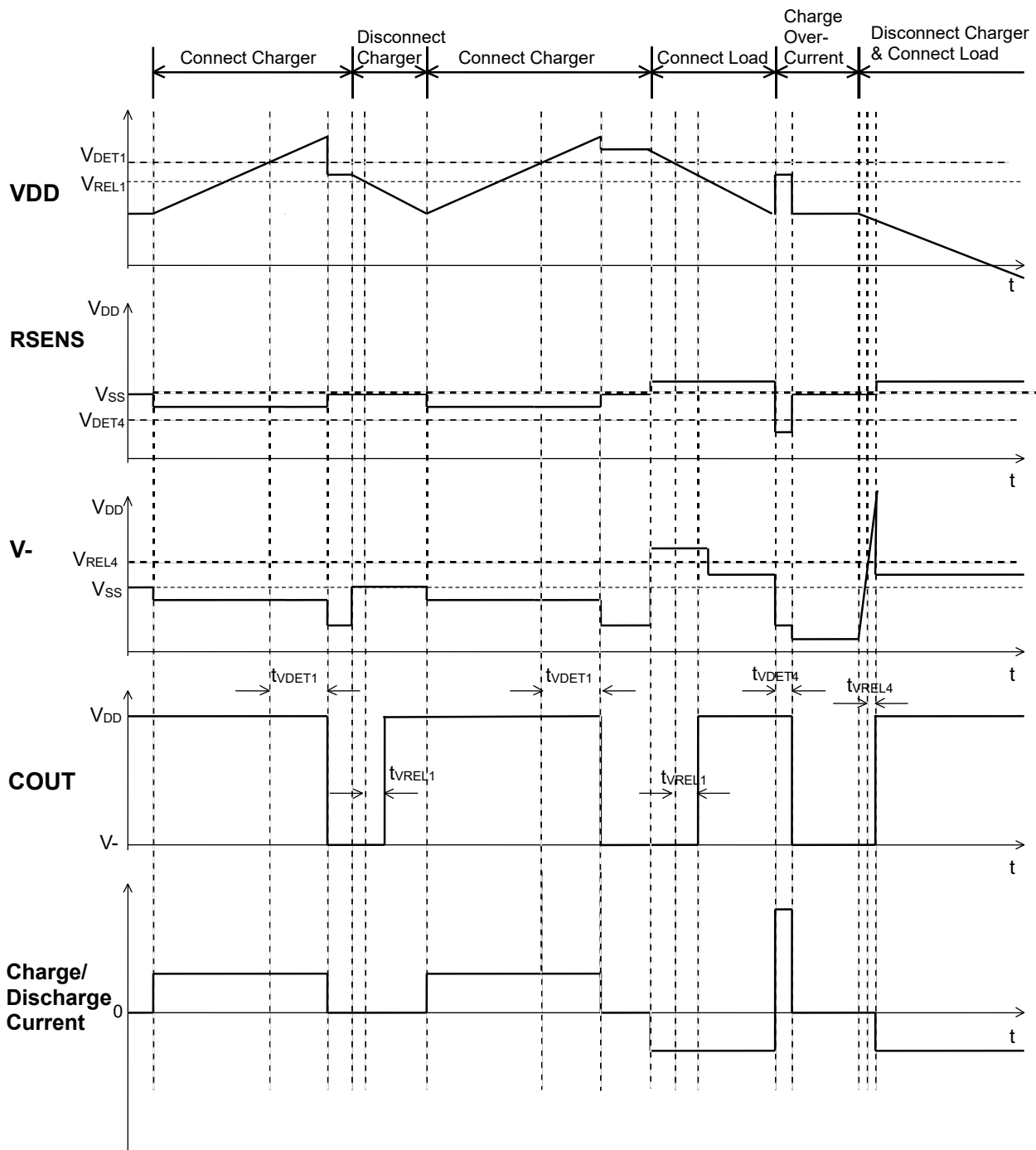

Overcharge (Auto Release type) Timing Diagram

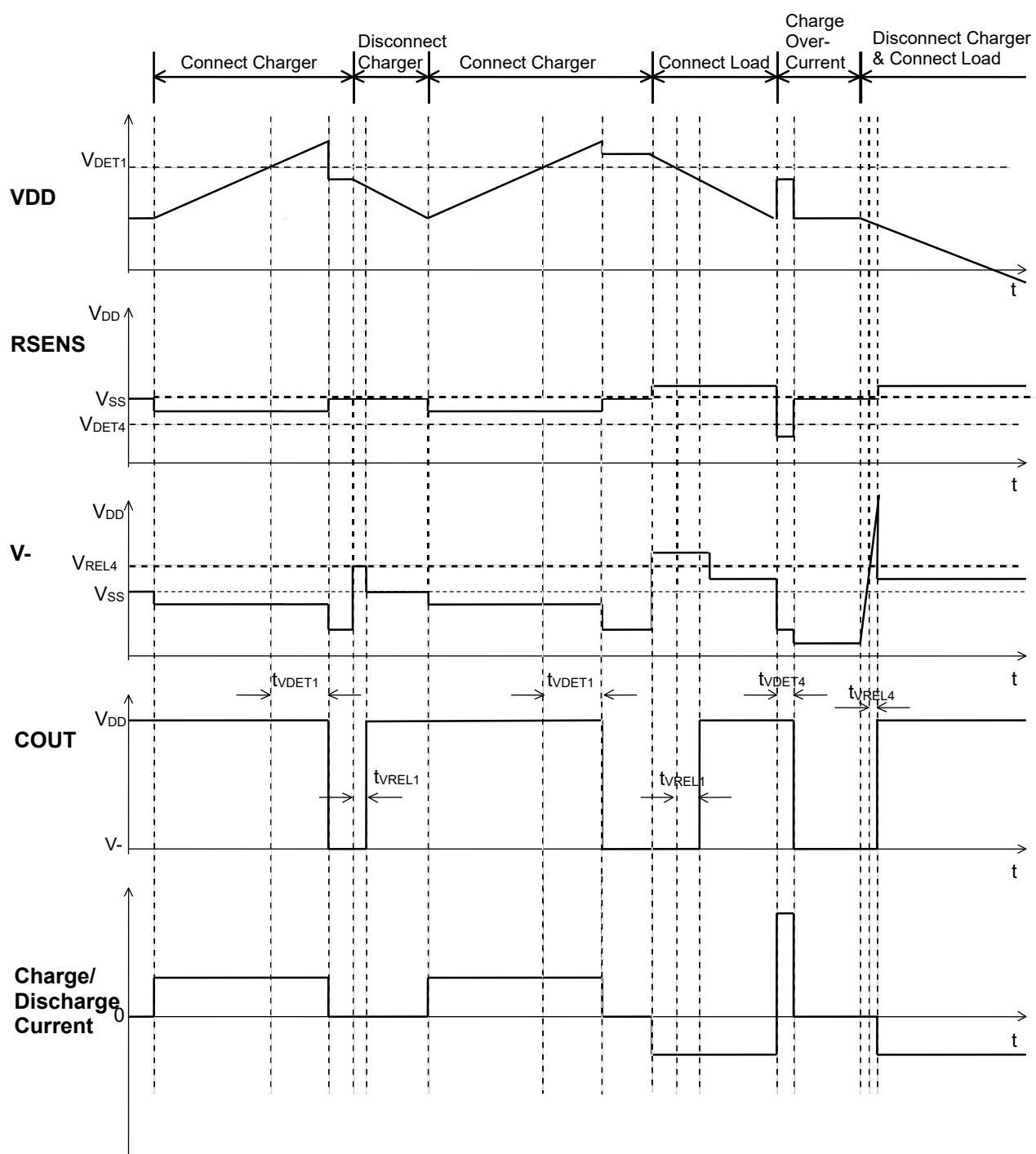

Overcharge (Latch type) Timing Diagram

Overdischarge, Discharge overcurrent, and Short-circuit

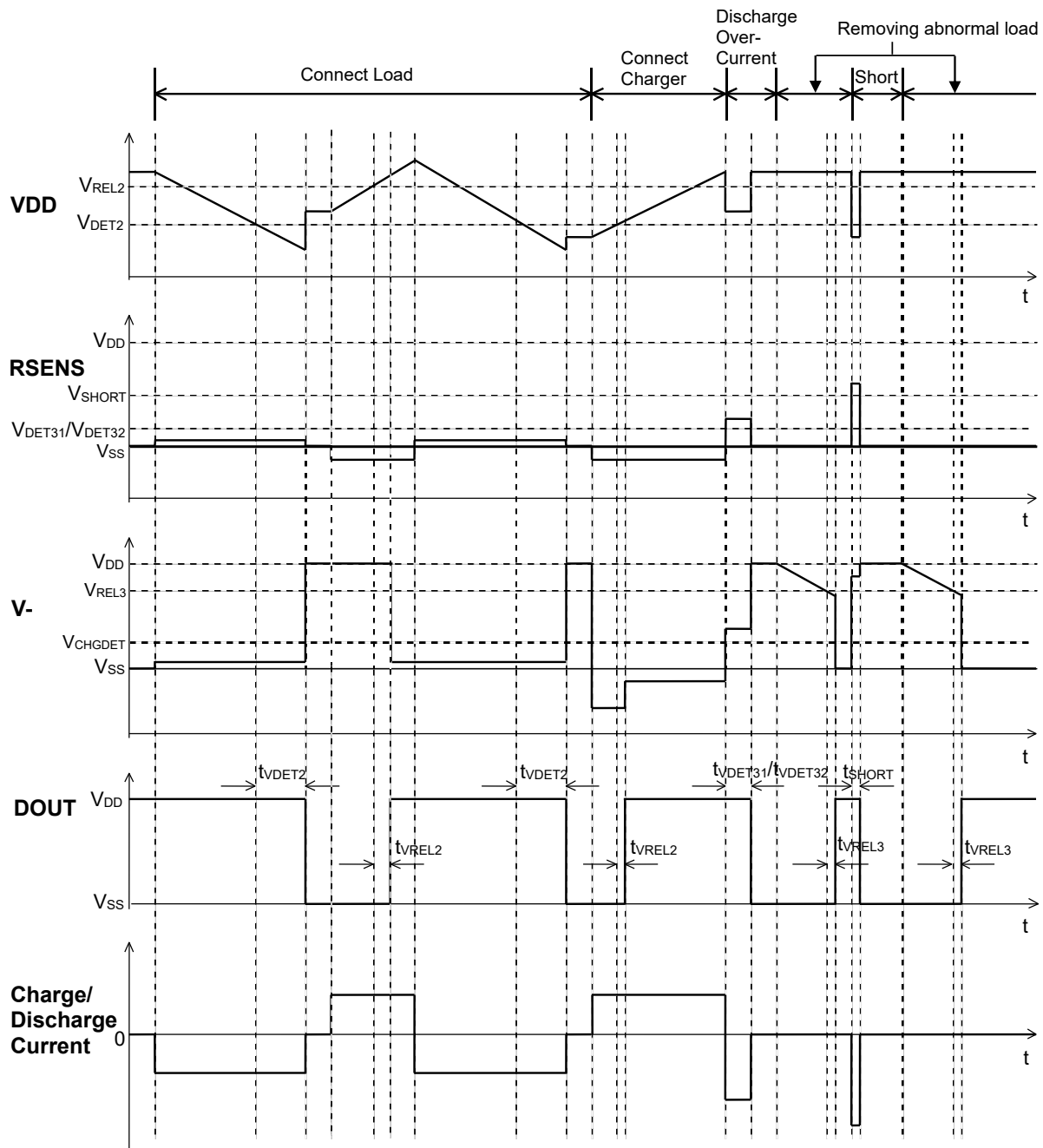

Overdischarge / Discharge Overcurrent (Auto Release type), Short-circuit Timing Diagram

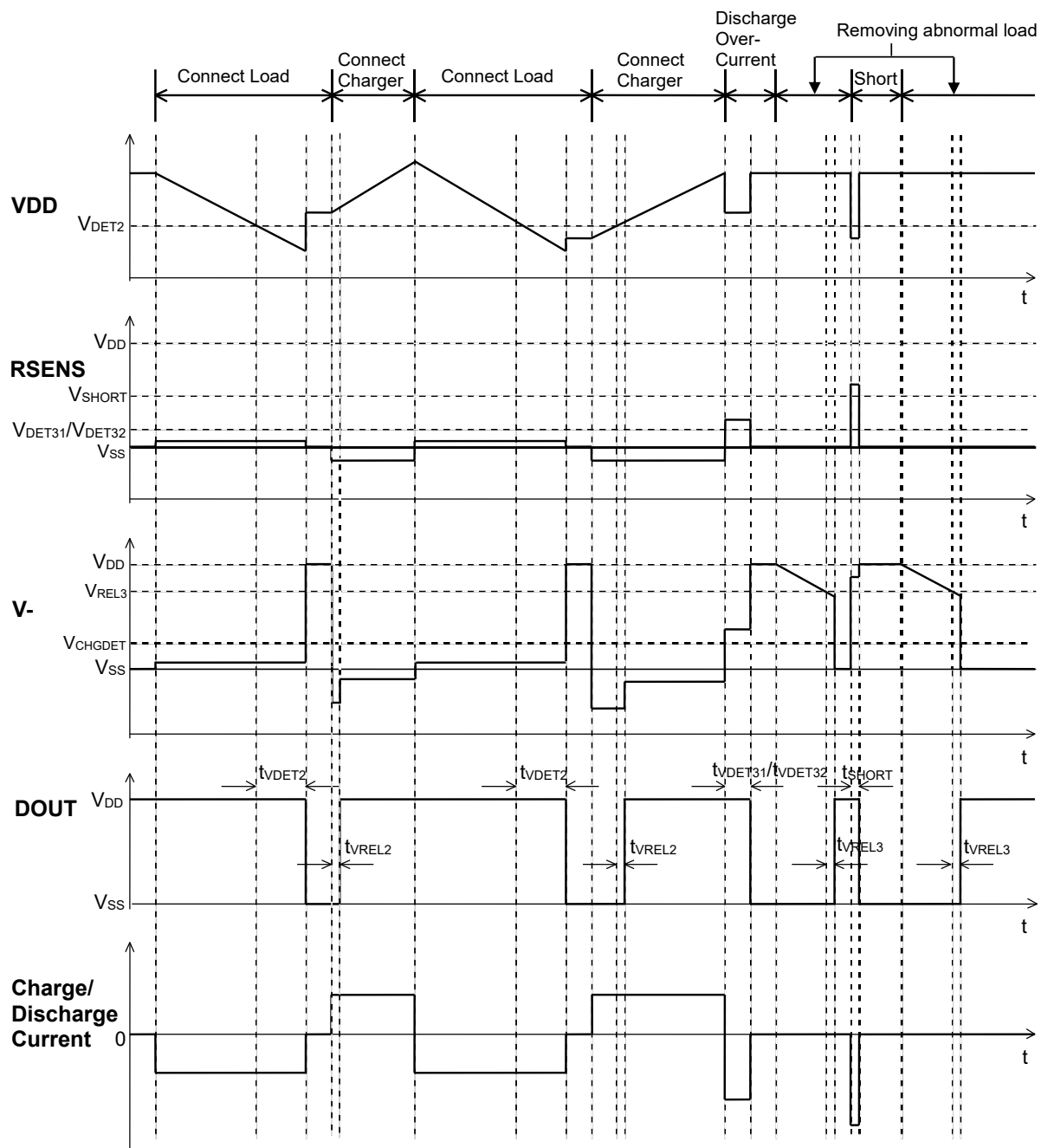

Overdischarge / Discharge Overcurrent (Latch type), Short-circuit Timing Diagram

RESET signal

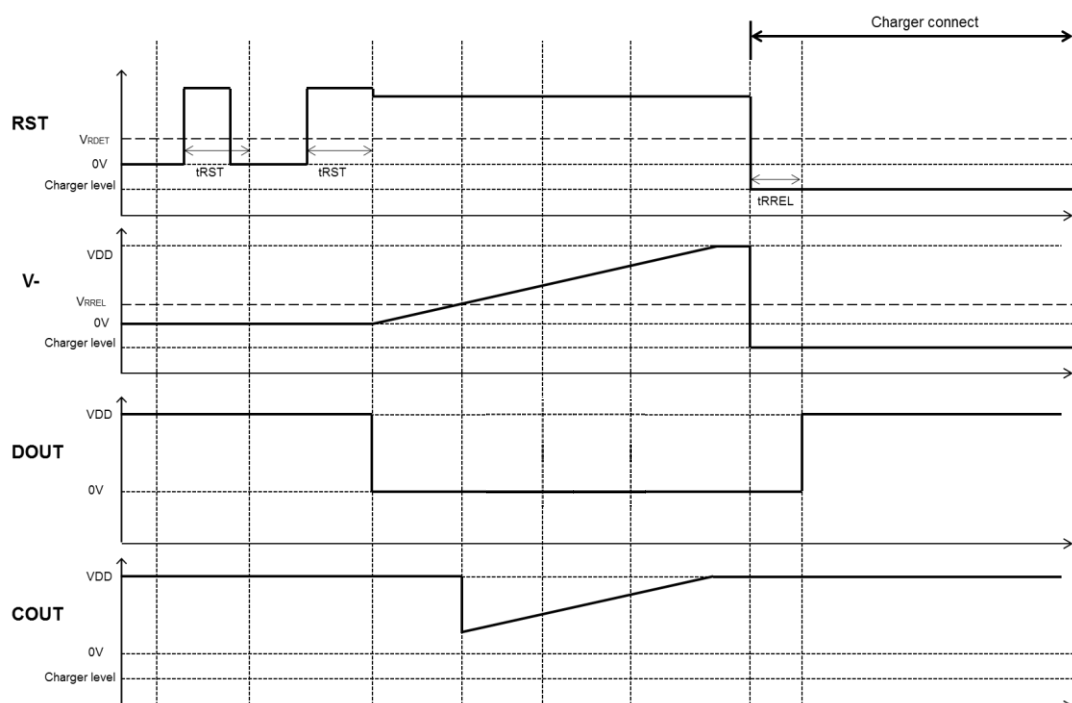
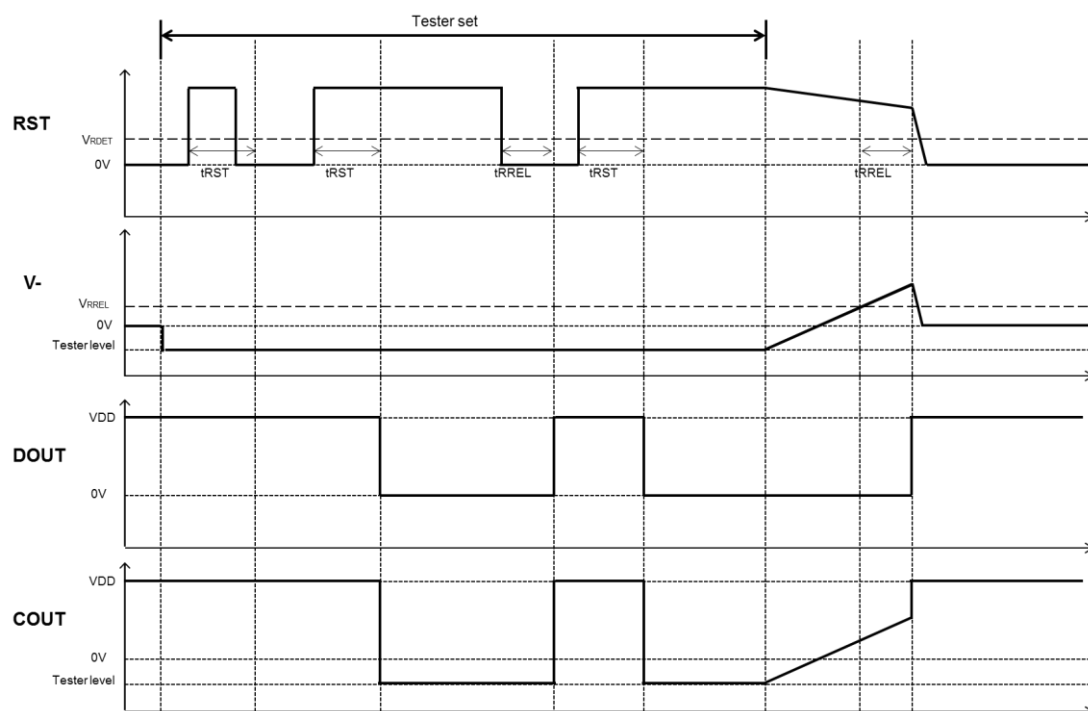

RST Pin Function (Forced-standby type) Timing Diagram

APPLICATION INFORMATION

Typical Application Circuit

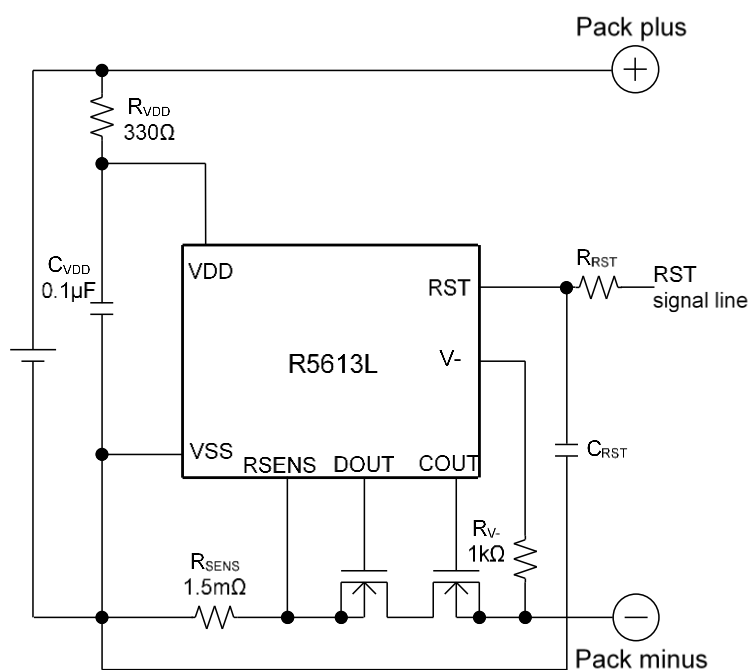

R5613LxxxXX Typical Application Circuit

External Components

Symbol	Min.	Typ.	Max.
Resistor			
R_{VDD} ⁽¹⁾		330Ω	1kΩ
R_{V-} ⁽¹⁾	–	1kΩ	1.3kΩ
R_{SENS}	–	1.5mΩ	–
R_{RST}	–	1kΩ	10kΩ
Capacitor			
C_{VDD}	0.01μF	0.1μF	1μF
C_{RST}	–	0.1μF	–

⁽¹⁾ The total resistance of R_{VDD} and R_{V-} must be 1kΩ or more.

Technical Notes on External Components

- The voltage fluctuation is stabilized with R_{VDD} and C_{VDD} . If a R_{VDD} is too large, the detection voltage rises by the conduction current at detection. To stabilize the operation, it is recommended to use a resistor of $1k\Omega$ or less for R_{VDD} and a capacitor of $0.01\ \mu\text{F}$ to $1.0\ \mu\text{F}$ for C_{VDD} .
- R_{VDD} and R_{V-} serve as a current limit resistor when the battery pack is charged with reversed polarity or a voltage of the connected charger is more than the absolute maximum rating. When using a small resistor for R_{VDD} and R_{V-} , the device's power dissipation might be exceeded. Therefore, a total of R_{VDD} and R_{V-} must be $1k\Omega$ or more. When using a large resistor for R_{V-} , the charger might not be released by re-connecting to the battery pack after the overdischarge detection. Therefore, R_{V-} must be $1.3\ k\Omega$ or less. Production variation and temperature properties are included in the value. R_{SENS} is a resistor for sensing an overcurrent. If the resistance value is too large, power loss becomes also large. By the overcurrent, if the R_{SENS} is not appropriate, the power loss may be beyond the power dissipation of R_{SENS} . Choose an appropriate R_{SENS} according to the cell specification.
- The typical application circuit diagrams are just examples. This circuit performance largely depends on the PCB layout and external components. In the actual application, fully evaluation is necessary.
- If the positive terminal and the negative terminal of the battery pack are short even though the device has the short protection circuit, a large current may flow through the FET during the short detection delay time. Therefore, select an appropriate FET with large enough current capacitance in order to endure the large current during the delay time.

Selection of External Sense Resistor and MOSFET

Short mode is detected by the current base or the relation between V_{DD} at short and total on resistance of external MOSFETs for C_{OUT} and D_{OUT} . If short must be detected by the current base determined by V_{SHORT1} , V_{SHORT2} , and R_{SENS} , the next formula must be true, otherwise, the short current limit becomes $(V_{SHORT2}) / (R_{SENS} + R_{SS}(\text{on}))$.

$$\frac{V_{SHORT2}}{R_{SENS} + R_{SS}(\text{on})} \geq \frac{V_{SHORT1}}{R_{SENS}}$$

V_{SHORT1} = Threshold value of detecting short circuit using R_{SENS} terminal [V]

V_{SHORT2} = Threshold value of detecting short circuit using V- terminal [V]

R_{SENS} : = External current sense resistance [Ω]

$R_{SS}(\text{on})$ = external MOSFETs' total ON resistance [Ω]

In the short mode, a short current is determined by the relation between R_{SENS} and V_{SHORT} value.

TECHNICAL NOTES

A peripheral component or the device mounted on PCB should not exceed a rated voltage, a rated current or a rated power. When designing a peripheral circuit, please be fully aware of the following points.

- Please evaluate the product at the PCB level before use, as some symptoms may remain that cannot be confirmed by the evaluation at the IC level.
- When using any coating or underfill to improve moisture resistance or joining strength, evaluate them adequately before using. In certain materials or coating conditions, corrosion by contained constituents, current leakage by moisture absorption, crack and delamination by physical stress can happen. If the curing temperature of the coating material or underfill material exceeds the absolute maximum rating, the electrical characteristics of this product may change.
- When performing X-ray inspection in mass production process and evaluation build stage such as the product functions and characteristics confirmation, please confirm X-ray irradiation does not exceed 1.5Gy (absorbed dose for air).

The power dissipation of the package is dependent on PCB material, layout, and environmental conditions. The following measurement conditions are based on JEDEC STD. 51.

Measurement Conditions

Item	Measurement Conditions
Environment	Mounting on Board (Wind Velocity = 0 m/s)
Board Material	Glass Cloth Epoxy Plastic (Four-Layer Board)
Board Dimensions	76.2 mm × 114.3 mm × 1.6 mm
Copper Ratio	Outer Layer (First Layer): Less than 95% of 50 mm Square Inner Layers (Second and Third Layers): Approx. 100% of 50 mm Square Outer Layer (Fourth Layer): Approx. 100% of 50 mm Square
Through-holes	φ 0.25 mm × 24 pcs

Measurement Result

(Ta = 25°C, Tjmax = 125°C)

Item	Measurement Result
Power Dissipation	1160 mW
Thermal Resistance (θja)	θja = 86°C/W
Thermal Characterization Parameter (ψjt)	ψjt = 53°C/W

θja: Junction-to-Ambient Thermal Resistance

ψjt: Junction-to-Top Thermal Characterization Parameter

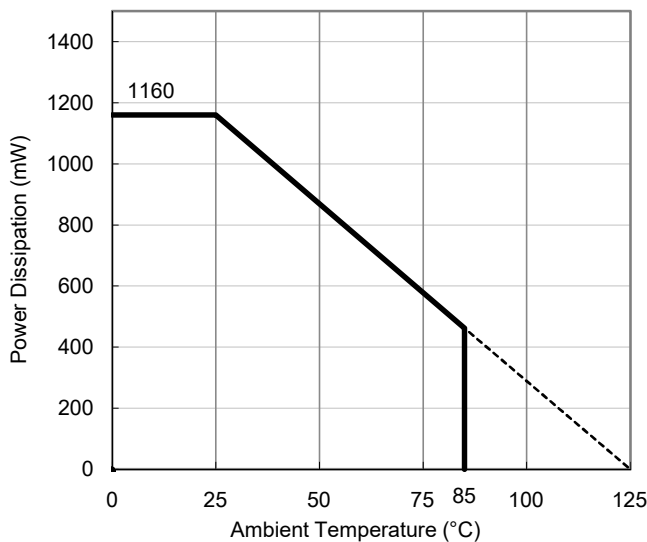

Power Dissipation vs. Ambient Temperature

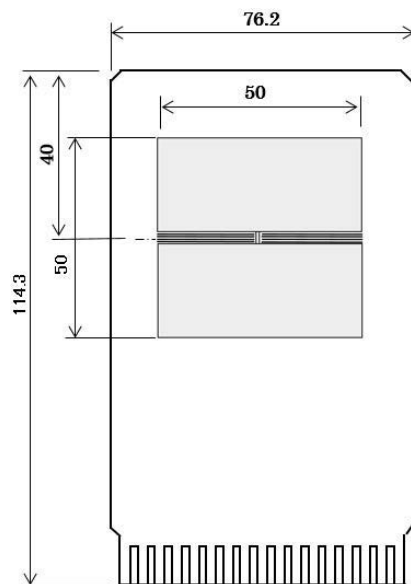

Measurement Board Pattern

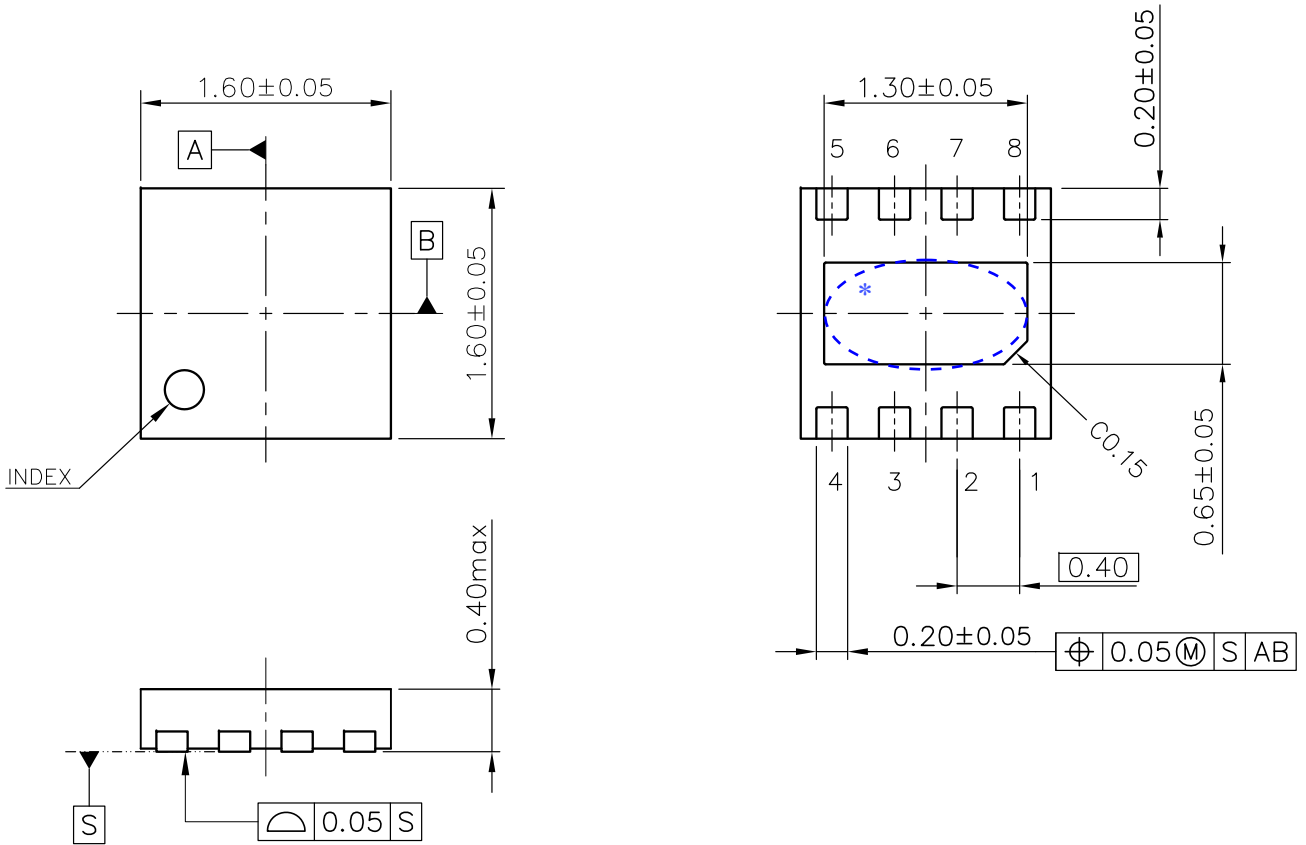

DFN1616-8B Package Dimensions (Unit:mm)

*The tab on the bottom of the package shown by blue circle is a substrate potential (V_{DD}). It is recommended that this tab be connected to the VDD pin on the board but it is possible to leave the tab floating.

①②③④: Product Code ··· Refer to *Part Marking List*

⑤⑥: Lot Number ··· Alphanumeric Serial Number

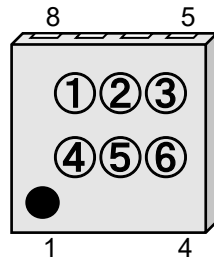

R5613L (DFN1616-8B) Part Markings

NOTICE

There can be variation in the marking when different AOI (Automated Optical Inspection) equipment is used. In the case of recognizing the marking characteristic with AOI, please contact our sales or distributor before attempting to use AOI.

R5613L Part Marking List

Product Name	①	②	③	④	Product Name	①	②	③	④
R5613L101AA	H	A	0	0	R5613L102FE	H	A	1	0
R5613L108AA	H	A	0	1	R5613L107GG	H	A	1	1
R5613L112AA	H	A	0	2	R5613L113GG	H	A	1	2
R5613L111DE	H	A	0	3	R5613L114EC	H	A	1	3
R5613L109GG	H	A	0	4	R5613L115GG	H	A	1	4
R5613L106AA	H	A	0	5	R5613L116DE	H	A	1	5
R5613L102DE	H	A	0	6	R5613L117GG	H	A	1	6
R5613L103EC	H	A	0	7	R5613L119GG	H	A	1	7
R5613L104ED	H	A	0	8	R5613L120GJ	H	A	1	8
R5613L110ED	H	A	0	9					

1. The products and the product specifications described in this document are subject to change or discontinuation of production without notice for reasons such as improvement. Therefore, before deciding to use the products, please refer to our sales representatives for the latest information thereon.
2. The materials in this document may not be copied or otherwise reproduced in whole or in part without the prior written consent of us.
3. This product and any technical information relating thereto are subject to complementary export controls (so-called KNOW controls) under the Foreign Exchange and Foreign Trade Law, and related politics ministerial ordinance of the law. (Note that the complementary export controls are inapplicable to any application-specific products, except rockets and pilotless aircraft, that are insusceptible to design or program changes.) Accordingly, when exporting or carrying abroad this product, follow the Foreign Exchange and Foreign Trade Control Law and its related regulations with respect to the complementary export controls.
4. The technical information described in this document shows typical characteristics and example application circuits for the products. The release of such information is not to be construed as a warranty of or a grant of license under our or any third party's intellectual property rights or any other rights.
5. The products listed in this document are intended and designed for use as general electronic components in standard applications (office equipment, telecommunication equipment, measuring instruments, consumer electronic products, amusement equipment etc.). Those customers intending to use a product in an application requiring extreme quality and reliability, for example, in a highly specific application where the failure or misoperation of the product could result in human injury or death should first contact us.
 - Aerospace Equipment
 - Equipment Used in the Deep Sea
 - Power Generator Control Equipment (nuclear, steam, hydraulic, etc.)
 - Life Maintenance Medical Equipment
 - Fire Alarms / Intruder Detectors
 - Vehicle Control Equipment (automotive, airplane, railroad, ship, etc.)
 - Various Safety Devices
 - Traffic control system
 - Combustion equipment

In case your company desires to use this product for any applications other than general electronic equipment mentioned above, make sure to contact our company in advance. Note that the important requirements mentioned in this section are not applicable to cases where operation requirements such as application conditions are confirmed by our company in writing after consultation with your company.

6. We are making our continuous effort to improve the quality and reliability of our products, but semiconductor products are likely to fail with certain probability. In order to prevent any injury to persons or damages to property resulting from such failure, customers should be careful enough to incorporate safety measures in their design, such as redundancy feature, fire containment feature and fail-safe feature. We do not assume any liability or responsibility for any loss or damage arising from misuse or inappropriate use of the products.
7. The products have been designed and tested to function within controlled environmental conditions. Do not use products under conditions that deviate from methods or applications specified in this datasheet. Failure to employ the products in the proper applications can lead to deterioration, destruction or failure of the products. We shall not be responsible for any bodily injury, fires or accident, property damage or any consequential damages resulting from misuse or misapplication of the products.
8. **Quality Warranty**
 - 8-1. **Quality Warranty Period**

In the case of a product purchased through an authorized distributor or directly from us, the warranty period for this product shall be one (1) year after delivery to your company. For defective products that occurred during this period, we will take the quality warranty measures described in section 8-2. However, if there is an agreement on the warranty period in the basic transaction agreement, quality assurance agreement, delivery specifications, etc., it shall be followed.
 - 8-2. **Quality Warranty Remedies**

When it has been proved defective due to manufacturing factors as a result of defect analysis by us, we will either deliver a substitute for the defective product or refund the purchase price of the defective product.
Note that such delivery or refund is sole and exclusive remedies to your company for the defective product.
 - 8-3. **Remedies after Quality Warranty Period**

With respect to any defect of this product found after the quality warranty period, the defect will be analyzed by us. On the basis of the defect analysis results, the scope and amounts of damage shall be determined by mutual agreement of both parties. Then we will deal with upper limit in Section 8-2. This provision is not intended to limit any legal rights of your company.
9. Anti-radiation design is not implemented in the products described in this document.
10. The X-ray exposure can influence functions and characteristics of the products. Confirm the product functions and characteristics in the evaluation stage.
11. WLCSP products should be used in light shielded environments. The light exposure can influence functions and characteristics of the products under operation or storage.
12. Warning for handling Gallium and Arsenic (GaAs) products (Applying to GaAs MMIC, Photo Reflector). These products use Gallium (Ga) and Arsenic (As) which are specified as poisonous chemicals by law. For the prevention of a hazard, do not burn, destroy, or process chemically to make them as gas or power. When the product is disposed of, please follow the related regulation and do not mix this with general industrial waste or household waste.
13. Please contact our sales representatives should you have any questions or comments concerning the products or the technical information.



Nisshinbo Micro Devices Inc.

Official website

<https://www.nisshinbo-microdevices.co.jp/en/>

Purchase information

<https://www.nisshinbo-microdevices.co.jp/en/buy/>