

1 to 3 Cells Li-Ion Battery Protection IC for Secondary Protection

No. EA-417-251215

OUTLINE

The R5438L is an overcharge protection IC for 1 to 3 serial cells Li-ion / Li-polymer rechargeable battery. This device provides the high-accuracy voltage detection function and the shutdown function can reduce the supply current to the minimum when all cell's voltage becomes less than the shutdown detection voltage.

FEATURES

- High Voltage Tolerant Process
Absolute Maximum Ratings 26 V
- Low Supply Current
During Operation, Cell-voltage: 3.9 V, 3-Cells Typ. 0.85 μ A
- High-accuracy Voltage Detection
Overcharge Detector Threshold ($V_{DET1n}^{(1)}$) 4.10 V to 4.70 V, in 5 mV step
Overcharge Detector Threshold Accuracy ± 0.02 V ($T_a = 25^\circ\text{C}$)
 ± 0.025 V ($0^\circ\text{C} \leq T_a \leq 60^\circ\text{C}$)
Overcharge Release Voltage ($V_{REL1n}^{(1)}$) $V_{DET1n} - 0\text{V}$ to $V_{DET1n} - 0.5\text{V}$, in 50 mV step
Overcharge Detection Delay Time 1-, 2-, 4-, or 6-sec with Delay Time Shortening Function⁽²⁾
Overcharge Release Voltage Condition Voltage Release Type
- COUT Output (CMOS Output, Active-high) Typ. 4.7 V
- Shutdown Functions
Shutdown Detector Threshold Typ. 3.5 V ± 0.3 V
Shutdown Current Max. 0.1 μ A
- 1 to 3 Cells Selectable Battery Protection
- Compact Package
DFN1814-6C 1.4mm x 1.8mm

APPLICATIONS

- Li-Ion or Li-Polymer Battery Protection

⁽¹⁾ V_{DET1n}, V_{REL1n} : n = 1, 2, 3

⁽²⁾ The delay time can be reduced down to approx. 1/90 by applying a 4 V ± 0.2 V to the VDD – VC1 pins.

SELECTION GUIDE

The overcharge and the delay time are user-selectable options.

Selection Guide

Product Name	Package	Quantity per Reel	Pb Free	Halogen Free
R5438Lxxx\$*-TR	DFN1814-6C	5,000 pcs	Yes	Yes

xxx: Specify the combination of the overcharge detector threshold (V_{DET1n}) and the overcharge release voltage (V_{REL1n})⁽¹⁾.

V_{DET1n} ⁽²⁾: 4.10 V to 4.70 V in 5 mV step

V_{REL1n} ⁽²⁾: $V_{DET1n} - 0$ V to $V_{DET1n} - 0.5$ V in 50 mV step

\$: Specify the combination of the overcharge detection delay time (t_{VDET1}) and the overcharge release delay time (t_{VREL1}). Refer to *Delay Time Code Table* for details.

Delay Time Code Table

Code	t_{VDET1} (s)	t_{VREL1} (ms)
A	2	16
B	4	16
C	6	16
D	1	16

*: Specify the function code.

Function Code Table

Code	Overcharge Released Condition	COUT Output	
A	Voltage Release	CMOS	"H" Active

⁽¹⁾ Refer to *Product Code Table* for details.

⁽²⁾ V_{DET1n}, V_{REL1n} : n = 1, 2, 3

Product Code List

The product code is determined by the combination of the settable voltage (overcharge detector threshold: V_{DET1n} and overcharge release voltage: V_{REL1n}) and the delay time (overcharge detection delay time: t_{VDET1} and overcharge release delay time: t_{VREL1}) and the function code.

Product Code Table

Product Name	Settable Voltage (V)		Delay Time	
	V_{DET1n}	V_{REL1n}	$t_{VDET1}(s)$	$t_{VREL1}(ms)$
R5438L301AA	4.450	4.150	2	16
R5438L301BA	4.450	4.150	4	16
R5438L303AA	4.350	4.050	2	16
R5438L303BA	4.350	4.050	4	16
R5438L304AA	4.400	4.100	2	16
R5438L304BA	4.400	4.100	4	16
R5438L305AA	4.300	4.000	2	16
R5438L305BA	4.300	4.000	4	16
R5438L306CA	4.450	3.950	6	16
R5438L308BA	4.400	4.000	4	16
R5438L312AA	4.550	4.150	2	16
R5438L312BA	4.550	4.150	4	16
R5438L312CA	4.550	4.150	6	16
R5438L315AA	4.500	4.150	2	16
R5438L317BA	4.500	4.200	4	16
R5438L322BA	4.600	4.150	4	16
R5438L326DA	4.550	4.200	1	16
R5438L327AA	4.300	4.200	2	16
R5438L328BA	4.600	4.250	4	16
R5438L329BA	4.650	4.300	4	16
R5438L330AA	4.200	4.100	2	16
R5438L331BA	4.700	4.350	4	16
R5438L332BA	4.540	4.200	4	16
R5438L333BA	4.275	3.975	4	16

Please contact our sales representatives if required a product code other than the above combinations.

BLOCK DIAGRAM

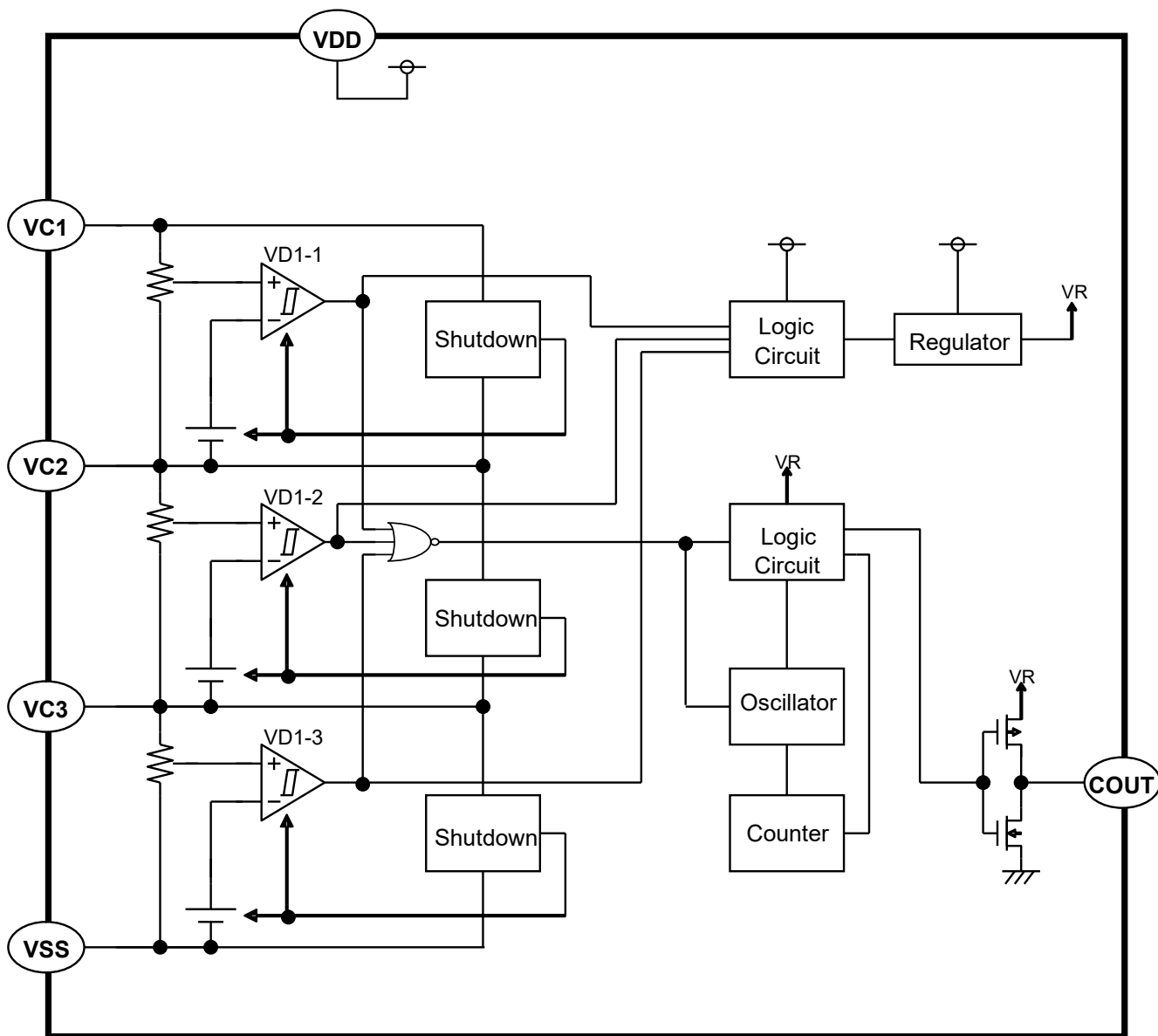

R5438L Block Diagram

PIN DESCRIPTIONS

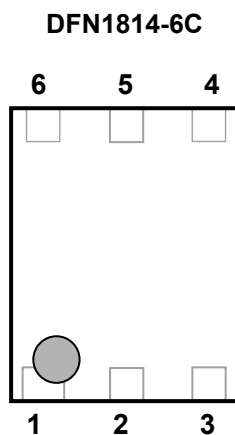

DFN1814-6C Pin Assignment

Pin No.	Symbol	Description
1	COUT	Overcharge Detection Output Pin
2	VDD	Power Supply Pin
3	VC1	CELL1 Plus Pin
4	VC2	CELL2 Plus Pin
5	VC3	CELL3 Plus Pin
6	VSS	IC Ground Pin

ABSOLUTE MAXIMUM RATINGS

Absolute Maximum Ratings

(Ta = 25°C, V_{SS} = 0 V)

Symbol	Item	Rating	Unit
V _{DD}	Power Supply Voltage	V _{C1} -0.3 to V _{C1} +6.5	V
		V _{C1} -0.3 to 26	V
V _{C1}	CELL1 Plus Pin Input Voltage	V _{C2} -0.3 to V _{C2} +6.5	V
V _{C2}	CELL2 Plus Pin Input Voltage	V _{C3} -0.3 to V _{C3} +6.5	V
V _{C3}	CELL3 Plus Pin Input Voltage	-0.3 to 6.5	V
V _{COU} T	COU T Pin Output Voltage	-0.3 to V _{OH1} +0.3	V
P _D	Power Dissipation (Standard Land Pattern)	150	mW
T _j	Junction Temperature Range	-40 to 125	°C
T _{stg}	Storage Temperature Range	-55 to 125	°C

ABSOLUTE MAXIMUM RATINGS

Electronic and mechanical stress momentarily exceeded absolute maximum ratings may cause permanent damage and may degrade the lifetime and safety for both device and system using the device in the field. The functional operation at or over these absolute maximum ratings is not assured.

RECOMMENDED OPERATING CONDITION

Symbol	Item	Rating	Unit
V _{DD}	Operating Input Voltage	1.5 to 20 /	V
		V _{C1} +5 V	
T _a	Operating Temperature Range	-40 to 85	°C

RECOMMENDED OPERATING CONDITIONS

All of electronic equipment should be designed that the mounted semiconductor devices operate within the recommended operating conditions. The semiconductor devices cannot operate normally over the recommended operating conditions, even if they are used over such conditions by momentary electronic noise or surge. And the semiconductor devices may receive serious damage when they continue to operate over the recommended operating conditions.

ELECTRICAL CHARACTERISTICS

$V_{CELLn} = CELLn$ (Ex. V_{CELL1} is a voltage difference between VC1 and VC2) $n = 1, 2, 3$, unless otherwise noted.

The specifications surrounded by are guaranteed by Design Engineering at $0^{\circ}\text{C} \leq T_a \leq 60^{\circ}\text{C}$.

R5438L Electrical Characteristics

($T_a = 25^{\circ}\text{C}$)

Symbol	Item	Conditions	Min.	Typ.	Max.	Unit	Circuit (1)
V_{DET1n}	CELLn Overcharge Detection Voltage	Detect rising edge of supply voltage	V_{DET1n} -0.020V	V_{DET1n}	V_{DET1n} +0.020V	V	A
			 V_{DET1n} -0.025V		 V_{DET1n} +0.025V		
V_{REL1n}	CELLn Overcharge Release Voltage	Detect falling edge of supply voltage	V_{REL1n} -0.050V	V_{REL1n}	V_{REL1n} +0.050V	V	A
t_{VDET1}	Overcharge Detection Delay Time	$V_{CELLn} = 3.9\text{V}$ ($n=2,3$) $V_{CELL1} = 3.9\text{V} \rightarrow 4.7\text{V}$ ($V_{DET1} \leq 4.65\text{V}$) / 4.75V ($V_{DET1} > 4.65\text{V}$)	t_{VDET1} $\times 0.8$	t_{VDET1}	t_{VDET1} $\times 1.2$	s	B
t_{VREL1}	Overcharge Release Delay Time	$V_{CELLn} = 3.9\text{V}$ ($n=2,3$) $V_{CELL1} = 4.7\text{V}$ ($V_{DET1} \leq 4.65\text{V}$) / 4.75V ($V_{DET1} > 4.65\text{V}$) $\rightarrow 3.9\text{V}$	12.8	16	19.2	ms	B
V_{SHT}	Shutdown Detection Voltage	Detect falling edge of supply voltage	3.2	3.5	3.8	V	C
V_{OH1}	C_{OUT} Pch. ON Voltage 1	$I_{OH} = 0\mu\text{A}$, $V_{CELLn} = 4.7\text{V}$ ($V_{DET1} \leq 4.65\text{V}$) / 4.75V ($V_{DET1} > 4.65\text{V}$)	4.0	4.7	5.4	V	D
				V_{DD}			
V_{OH2}	C_{OUT} Pch. ON Voltage 2	$I_{OH} = -50\mu\text{A}$, $V_{CELLn} = 4.7\text{V}$ ($V_{DET1} \leq 4.65\text{V}$) / 4.75V ($V_{DET1} > 4.65\text{V}$)	V_{OH1} -0.5V	V_{OH1} -0.1V		V	E
V_{OL}	C_{OUT} Nch. ON Voltage	$I_{OL} = 50\mu\text{A}$, $V_{CELLn} = 3.9\text{V}$		0.1	0.5	V	F
I_{SHT}	Shutdown Current	$V_{CELLn} = 3.1\text{V}$			0.1	μA	G
I_{SS}	Supply Current	$V_{CELLn} = 3.9\text{V}$		0.85	1.7	μA	G

(1) Refer to TEST CIRCUITS for detail information.

TEST CIRCUITS

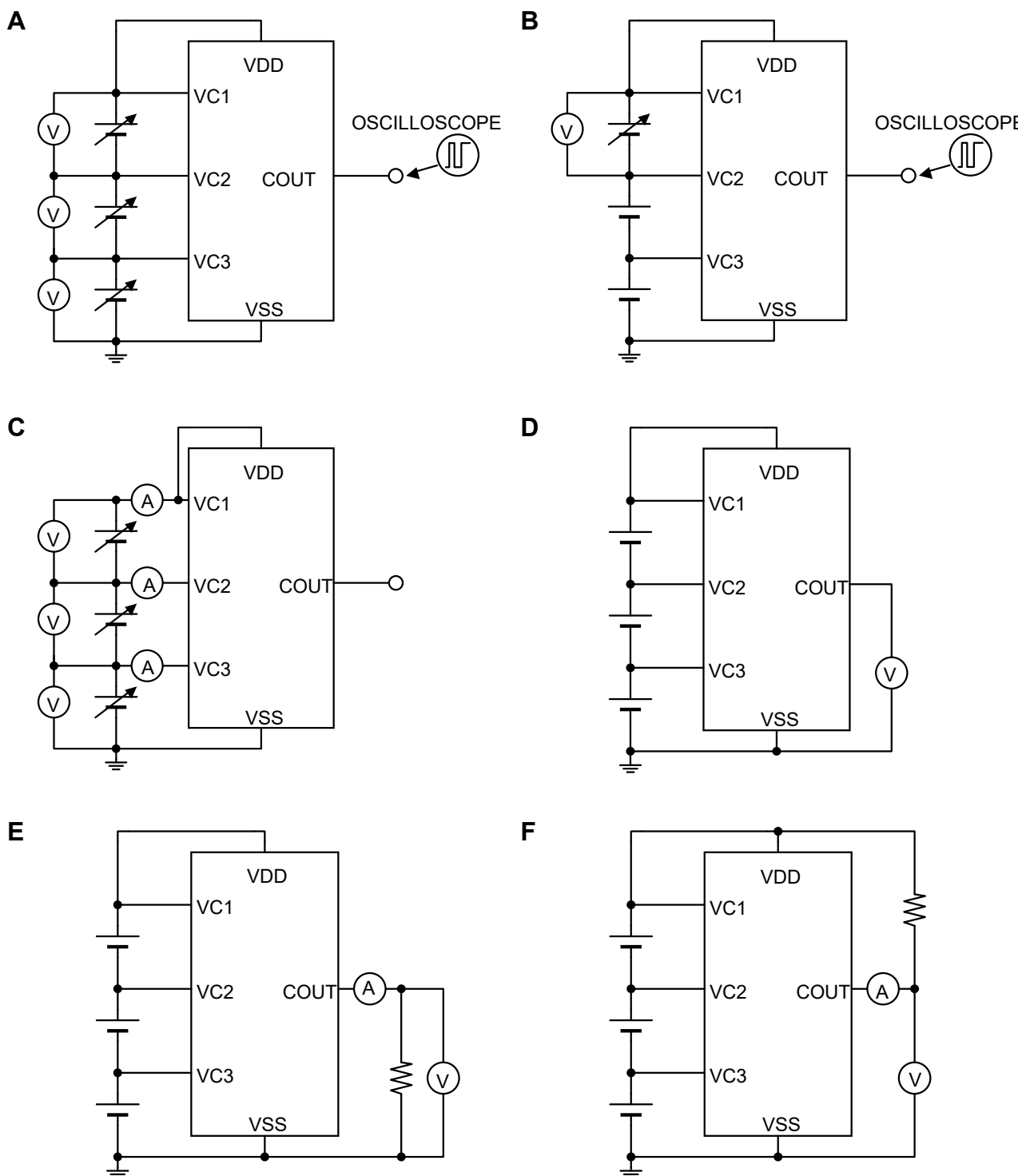

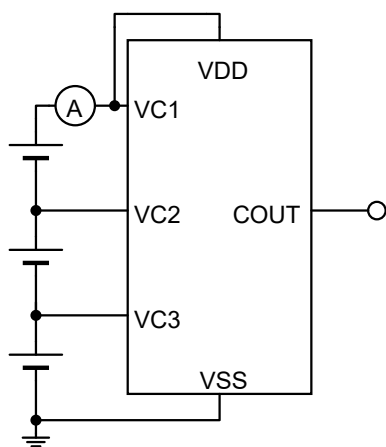
G

THEORY OF OPERATION

Overcharge Detection Circuit, VD1-n (n = 1, 2, 3)

(See the following timing chart)

While the cells are charged, the voltage between VC1 pin and VC2 pin (Cell-1 voltage), the voltage between VC2 pin and VC3 pin (Cell-2 voltage), and the voltage between VC3 pin and VSS pin (Cell-3 voltage) are supervised. If at least one of the cells' voltage becomes equal or more than the overcharge detector threshold, the overcharge is detected, and an external charge control Nch. FET turns on with COUT pin being at "H" level and by cutting a fuse on the charger path, and charge stops.

To reset the overcharge and make the COUT pin level to "L" again after detecting over-charge, in such conditions that a time when all the cells' voltages are down to a level lower than overcharge released voltage. Internal fixed output delay times for overcharge detection and release from over-charge exist. Even if one of voltage of the cells keeps its level more than the overcharge detector threshold, and output delay time passes, overcharge voltage is detected. After detecting overcharge, even if all the cell voltages become equal or less than the released voltage from overcharge, if at least one of the cells voltage becomes higher than the released voltage from overcharge within the output delay time of the release from overcharge, then overcharge is not released.

The output type of the COUT pin is CMOS output between VSS and the built-in regulator, and "H" level of COUT pin is the output voltage of the built-in regulator.

Shutdown Function

The voltage between VC1 pin and VC2 pin (Cell-1 voltage), the voltage between VC2 pin and VC3 pin (Cell-2 voltage), and the voltage between VC3 pin and VSS pin (Cell-3 voltage) are supervised. If the cell voltage becomes equal or less than the shutdown detector threshold, the overcharge detector of the cell is halted, as a result, the consumption current of IC itself (Shutdown current) is extremely reduced. If at least one of the cells voltage becomes higher than the shutdown detection voltage, the shutdown detection is released.

Delay Shortening (DS) Function

Applying a voltage of $4\text{ V} \pm 0.2\text{ V}$ between VDD and VC1 can shorten the overcharge detection delay time (t_{DET1}) into approximately 1/90, likewise, the overcharge release delay time (t_{REL1}) into approximately 1/60.

1-cell/ 2-cell Protection Alternative

By short-circuiting between cells, this device can meet as a protection IC for 1 or 3 cells placed in series.

The following table indicates pins to short-circuit depending on protected cells.

Protected Cells	Pins to short-circuit
1-cell protection	VC1 and VC2 pins, and VC3 and VSS pins
2-cell protection	VC1 and VC2 pins, or VC3 and VSS pins

If providing other connections except above short-circuit for 1 or 2 cells protection, perform thorough evaluation using the actual devices.

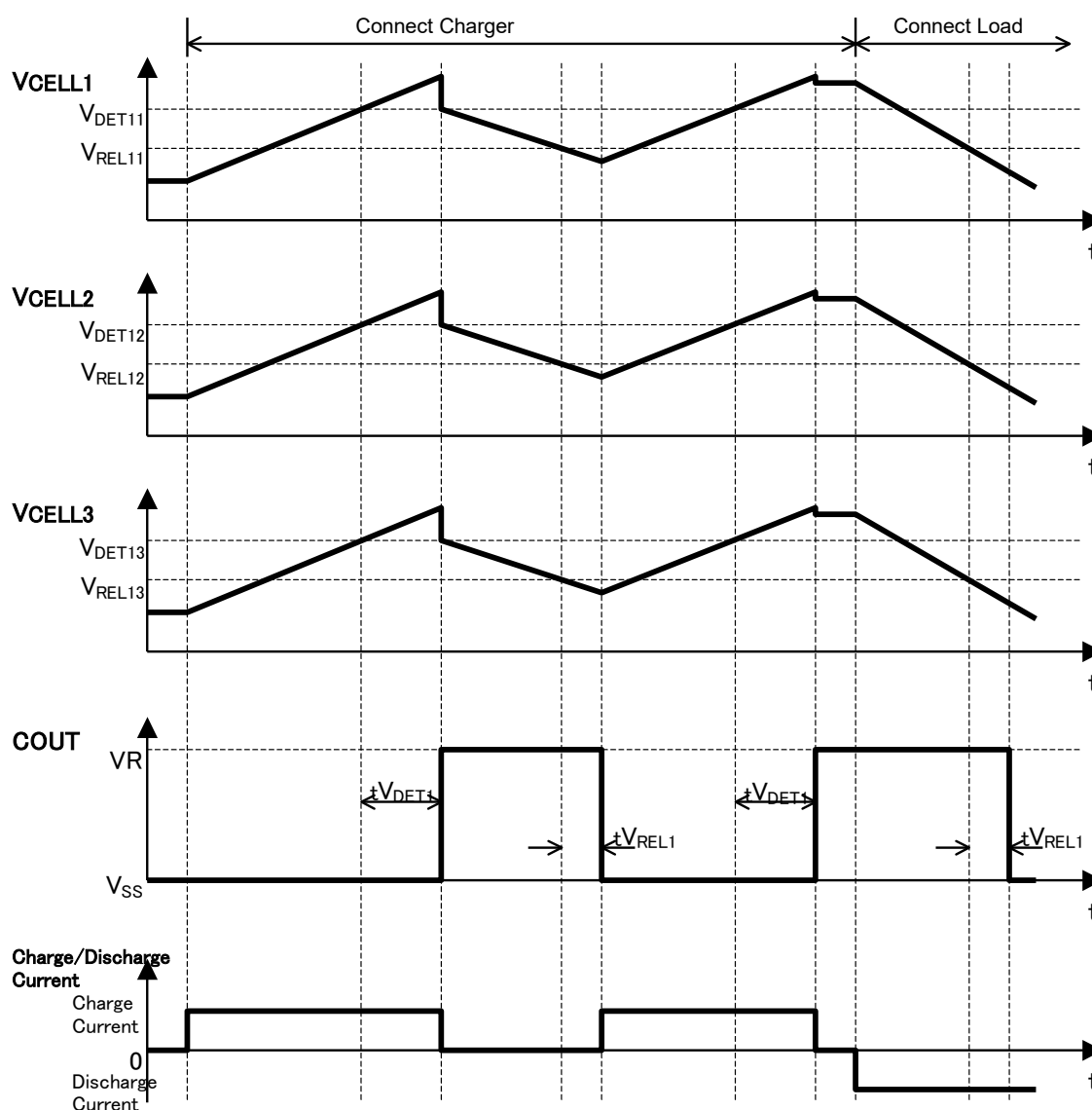

Overcharge Operation Timing Chart

APPLICATION INFORMATION

Typical Application Circuits in Normal Mode (CMOS Output, Active-high)

As for the order of cell's connection, connect a positive terminal of CELL1 as the end terminal. If connected another terminal, a fuse blowout might be caused by transiently "High" output of the COUT pin.

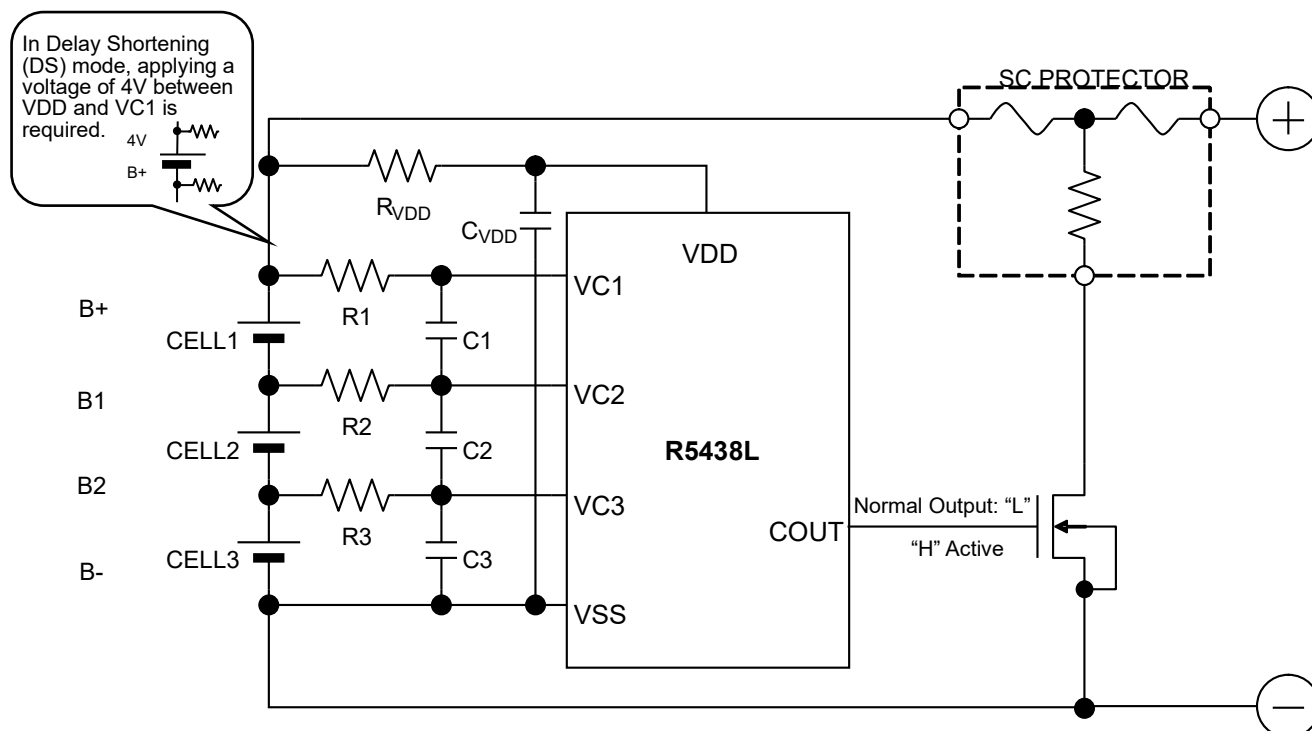

Typical Application Circuit for 3-cell Protection

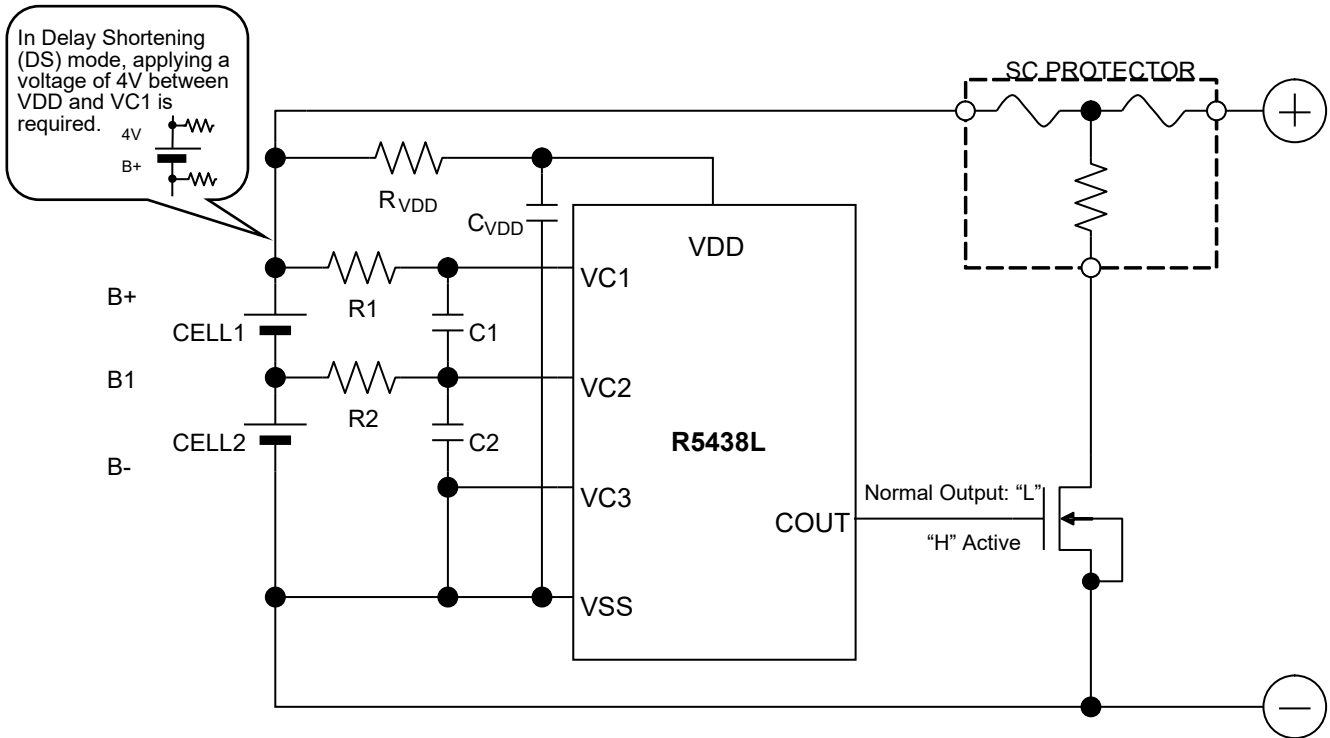

Typical Application Circuit for 2-cell Protection -1

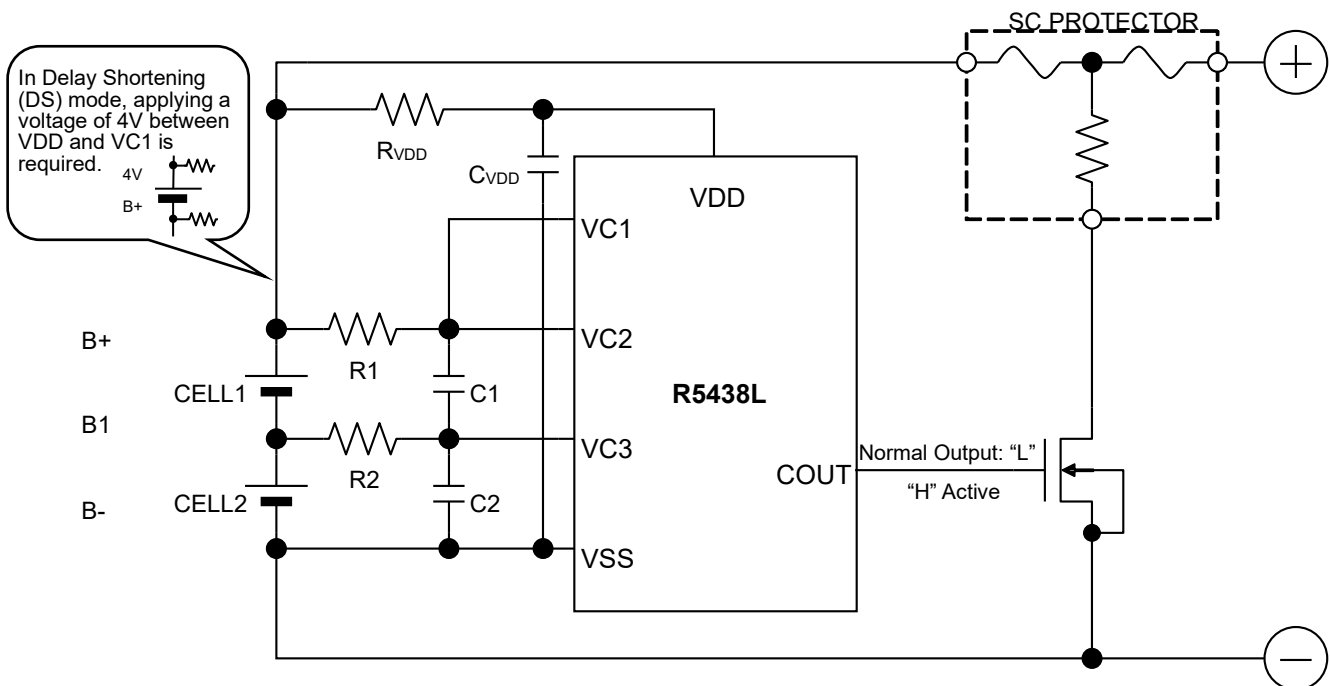

Typical Application Circuit for 2-cell Protection -2

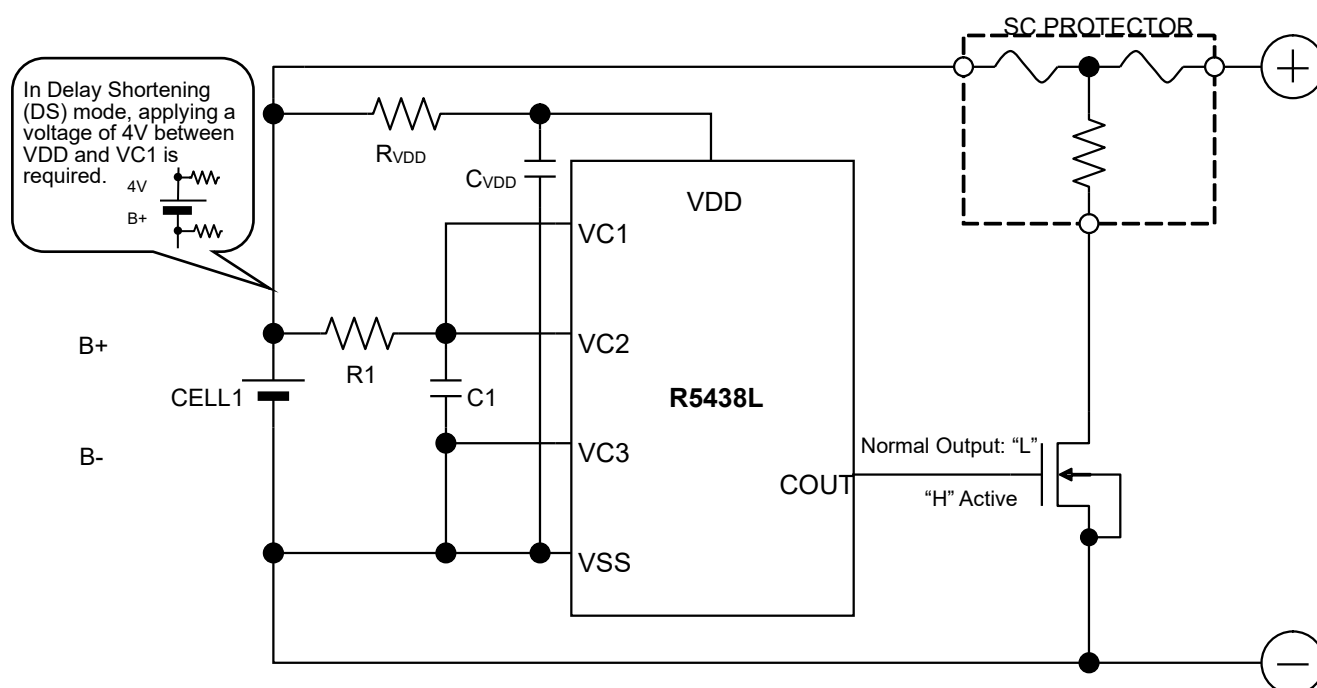

Typical Application Circuit for 1-cell Protection

External Components

Symbol	Typ.	Unit	Range
R_{VDD}	100	Ω	100 to 1000
R1	1000	Ω	330 to 1000
R2	1000	Ω	330 to 1000
R3	1000	Ω	330 to 1000
C_{VDD}	0.1	μF	0.01 to 1
C1	0.1	μF	0.01 to 1
C2	0.1	μF	0.01 to 1
C3	0.1	μF	0.01 to 1

Technical Notes on the Selection Components

- The voltage fluctuation is stabilized with R_{VDD} and C_{VDD} . If a small R_{VDD} is set, in the case of the large transient may happen to the cell voltage, by the flowing current, the IC may be unstable. If a large R_{VDD} is set, by the consumption current of the IC itself, the voltage difference between VDD pin and VC1 pin is generated, and unexpected operation may result. Therefore, the appropriate value range of R_{VDD} is from 100 Ω to 1 k Ω . To make a stable operation of the IC, the appropriate value range of C_{VDD} is from 0.01 μ F to 1.0 μ F.
- The voltage fluctuation is stabilized with R1 to R3 and C1 to C3. If a R1 to R3 is too large, by the conduction current at detection, the detector threshold may shift higher. Therefore, the appropriate value range of R1 to R3 is equal or less than 1 k Ω . To make a stable operation of the IC, the appropriate value range of C1 to C3 is 0.01 μ F or more.
- The typical application circuit diagrams are just examples. This circuit performance largely depends on the PCB layout and external components. In the actual application, fully evaluation is necessary.
- Overvoltage and the over current beyond the absolute maximum rating should not be forced to the protection IC and external components. During the time until the fuse is open after detecting overcharge, a large current may flow through the FET. Select an FET with large enough current capacity in order to endure the large current.
- To connect the SC protector, connect the SC protector to the cell must be the last.

Contact Information for Inquiries regarding SC PROTECTOR

Dexerials Corporation (Sony Chemical & Information Device Company Ltd.)

URL: <http://www.dexerials.jp>

TYPICAL CHARACTERISTICS

Part1. vs. Temperature

1) Celln Overcharge Detection Threshold vs. Temperature

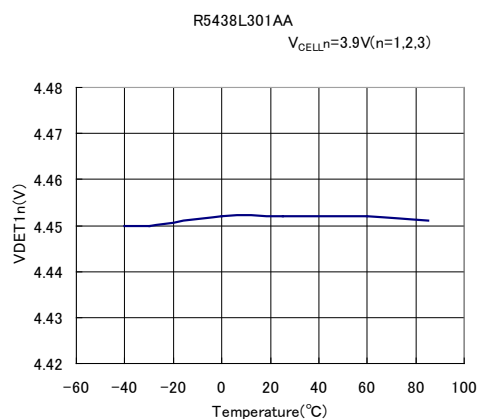

2) Celln Overcharge Release Voltage vs. Temperature

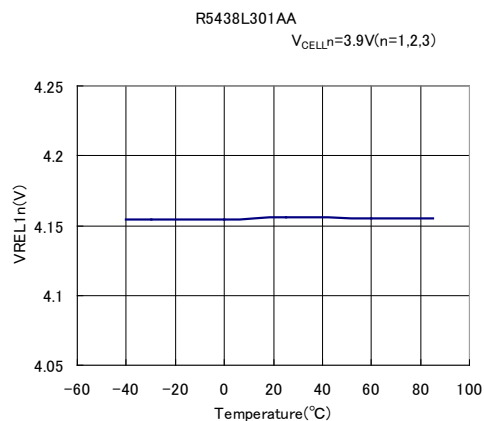

3) Overcharge Output delay Time vs. Temperature

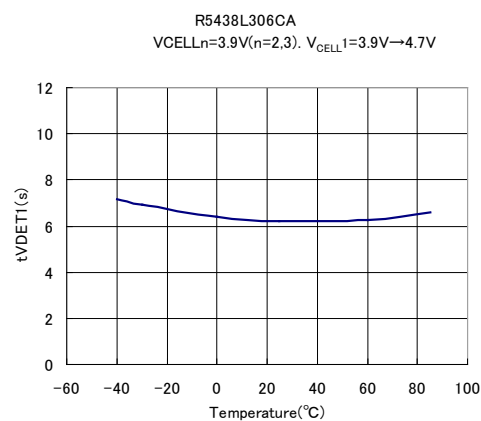
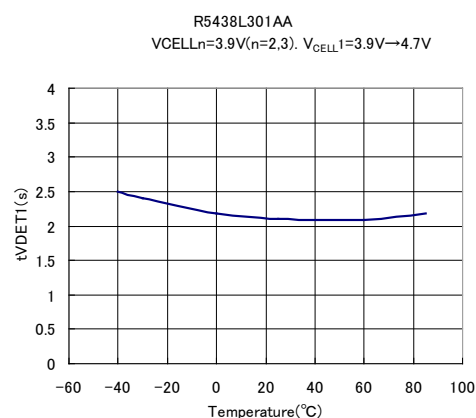

4) Released Delay Time from Overcharge vs. Temperature

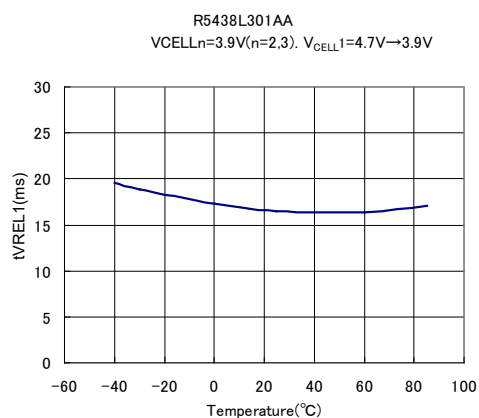

5) Celln Shutdown Threshold vs. Temperature

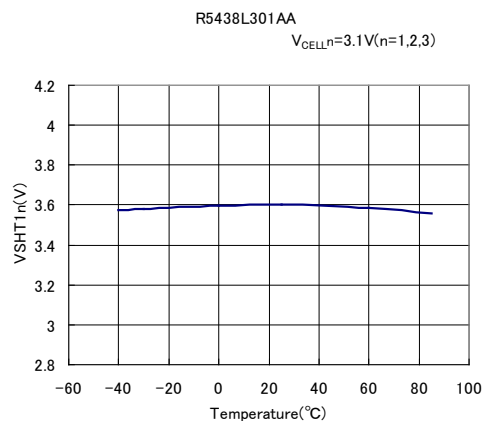

6) COUT Pch. On Voltage (No Load) vs. Temperature

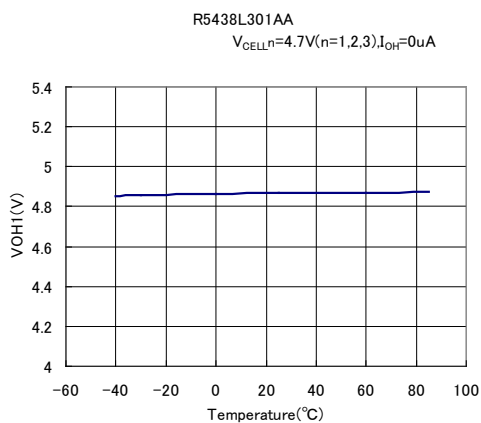

7) COUT Pch. On Voltage vs. Temperature

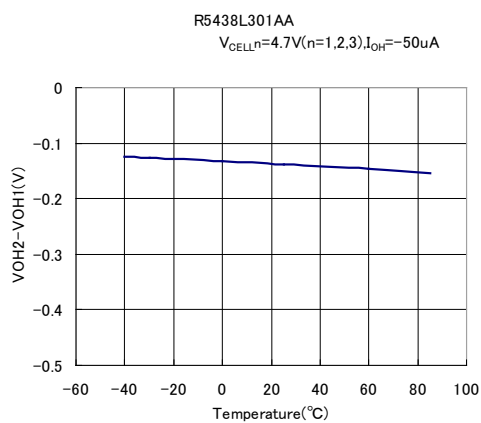

8) COUT Nch. On Voltage vs. Temperature

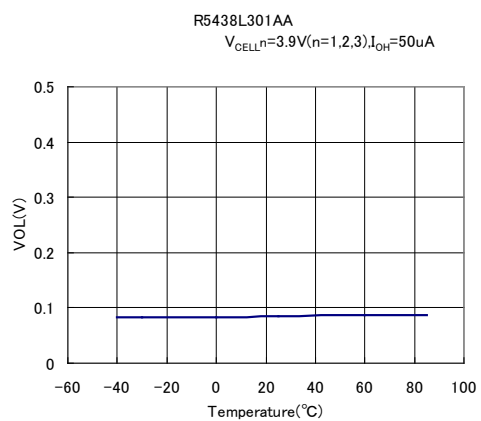

9) Shutdown Current vs. Temperature

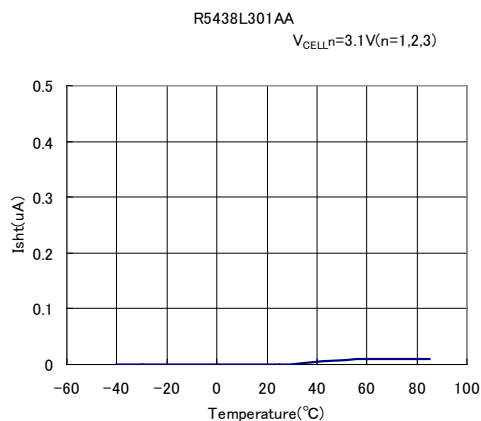

10) Supply Current vs. Temperature

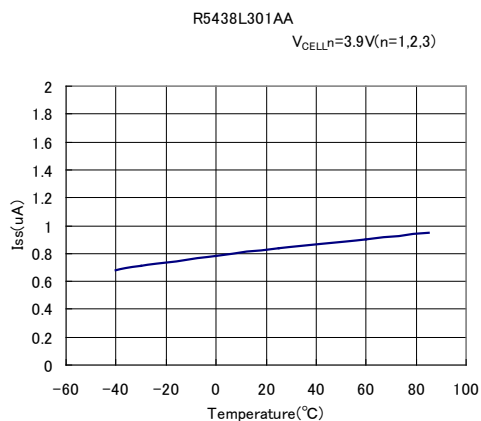

Part2. Supply Current vs. VDD (R5438L301AA)

3-cell Protection Supply Current vs. VDD

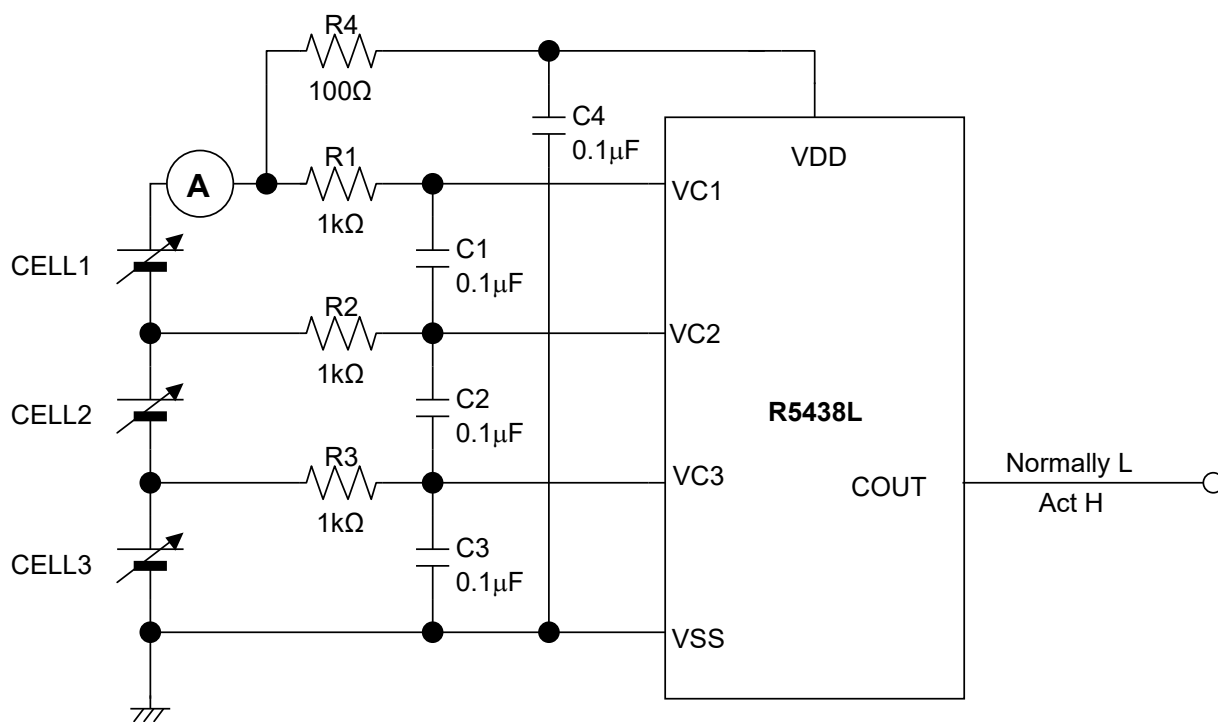
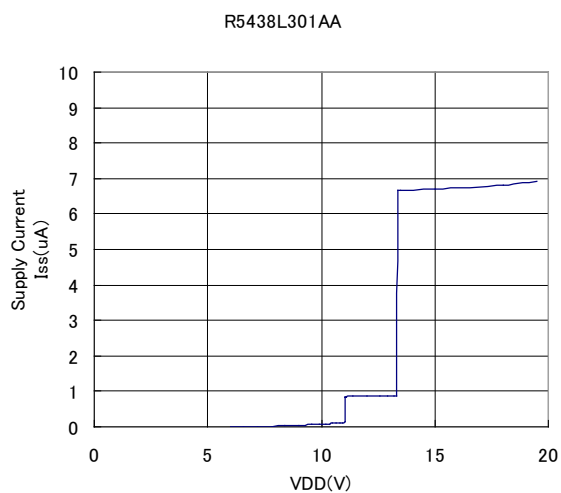

Test Circuit

Part3. vs. External Resister Dependence (R5438L301AA)
Overcharge Detection Voltage / Overcharge Release Voltage vs. R1

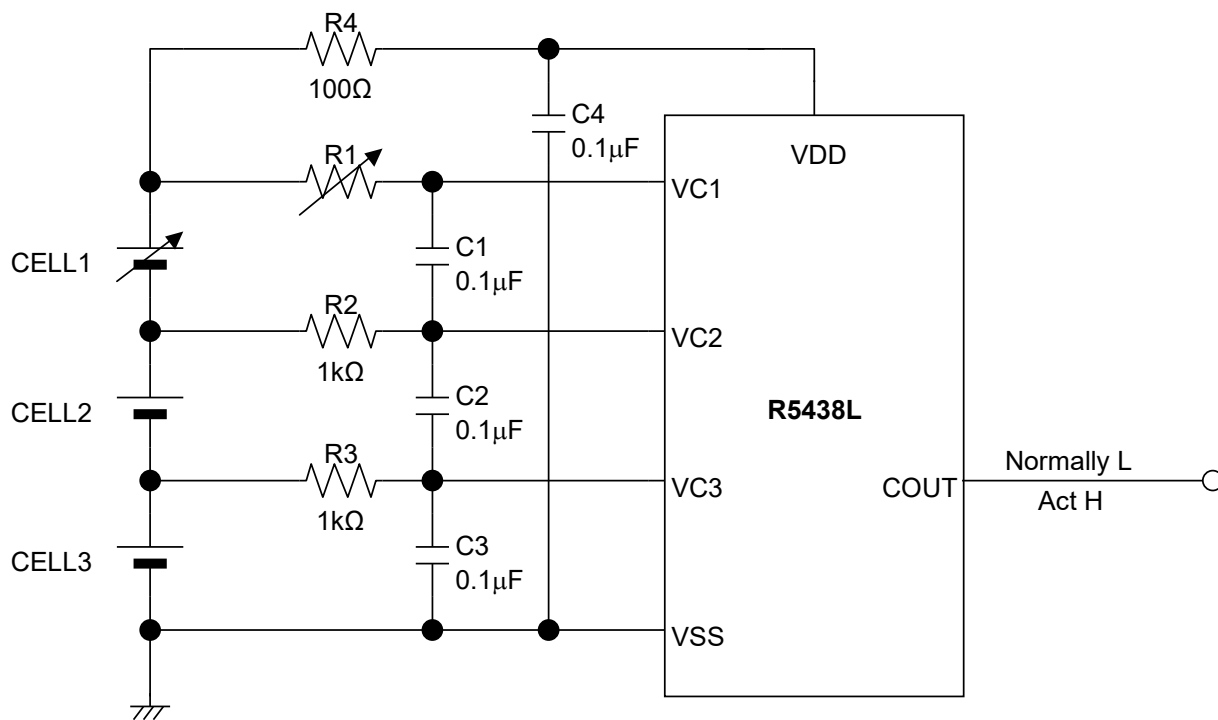
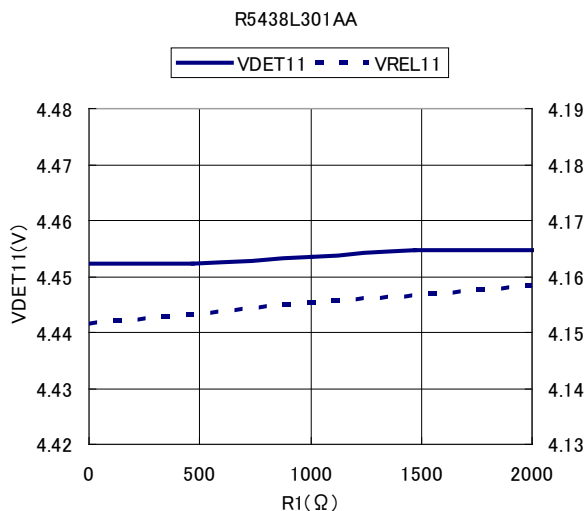

Test Circuit

TECHNICAL NOTES

A peripheral component or the device mounted on PCB should not exceed a rated voltage, a rated current or a rated power. When designing a peripheral circuit, please be fully aware of the following points.

- Please evaluate the product at the PCB level before use, as some symptoms may remain that cannot be confirmed by the evaluation at the IC level.
- When using any coating or underfill to improve moisture resistance or joining strength, evaluate them adequately before using. In certain materials or coating conditions, corrosion by contained constituents, current leakage by moisture absorption, crack and delamination by physical stress can happen. If the curing temperature of the coating material or underfill material exceeds the absolute maximum rating, the electrical characteristics of this product may change.
- When performing X-ray inspection in mass production process and evaluation build stage such as the product functions and characteristics confirmation, please confirm X-ray irradiation does not exceed 1.5Gy (absorbed dose for air).

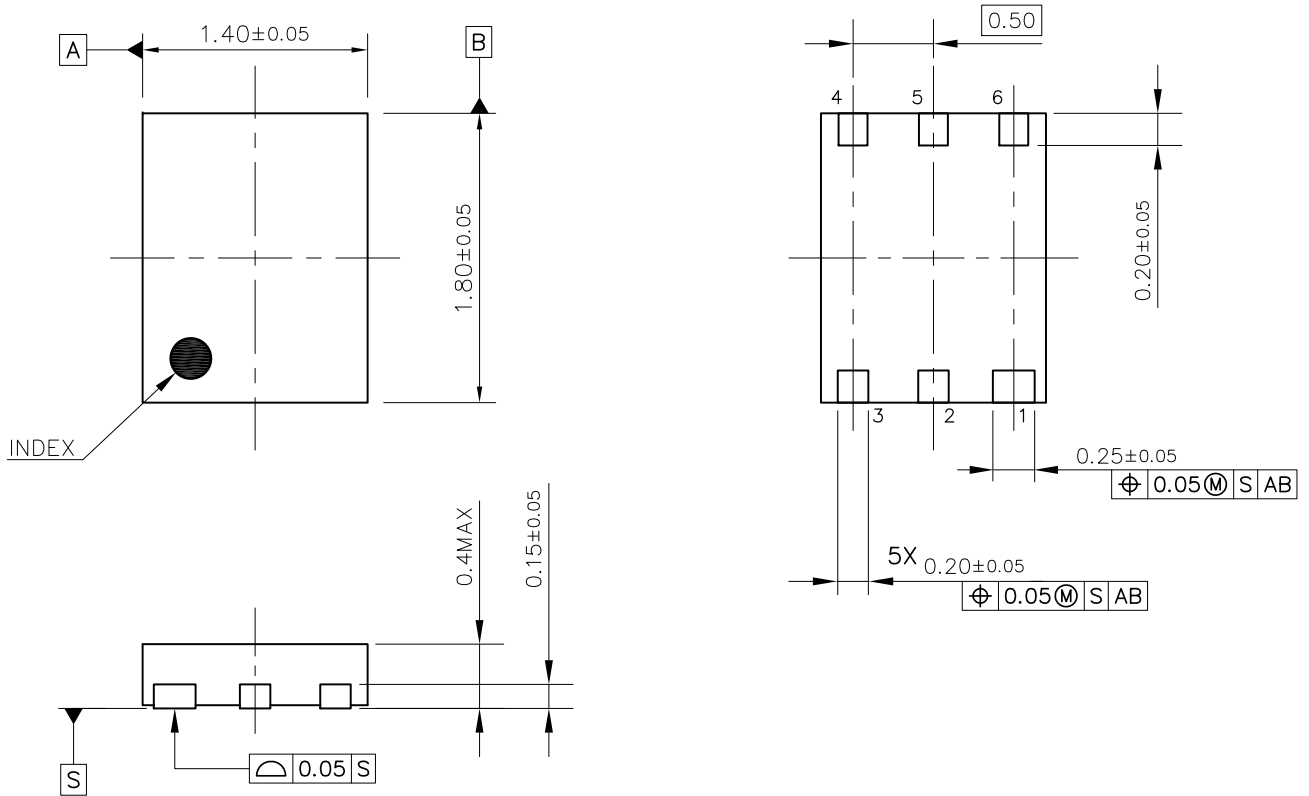

DFN1814-6C Package Dimensions (Unit: mm)

①②: Product Code ... Refer to *Part Marking List*

③④: Lot Number ... Alphanumeric Serial Number

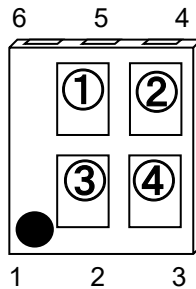

R5438L (DFN1814-6C) Part Markings

NOTICE

There can be variation in the marking when different AOI (Automated Optical Inspection) equipment is used. In the case of recognizing the marking characteristic with AOI, please contact our sales or distributor before attempting to use AOI.

R5438LxxxxA Part Marking List

Product Name	①	②	Product Name	①	②
R5438L301AA	H	A	R5438L329BA	J	D
R5438L306CA	H	B	R5438L330AA	J	E
R5438L301BA	H	C	R5438L331BA	J	F
R5438L305BA	H	D	R5438L332BA	J	G
R5438L308BA	H	E	R5438L312CA	J	H
R5438L305AA	H	F	R5438L333BA	J	J
R5438L303AA	H	G			
R5438L312BA	H	H			
R5438L304AA	H	J			
R5438L304BA	H	K			
R5438L312AA	H	L			
R5438L303BA	H	M			
R5438L315AA	H	N			
R5438L317BA	H	P			
R5438L322BA	H	R			
R5438L326DA	H	S			
R5438L327AA	H	Y			
R5438L328BA	J	B			

1. The products and the product specifications described in this document are subject to change or discontinuation of production without notice for reasons such as improvement. Therefore, before deciding to use the products, please refer to our sales representatives for the latest information thereon.
2. The materials in this document may not be copied or otherwise reproduced in whole or in part without the prior written consent of us.
3. This product and any technical information relating thereto are subject to complementary export controls (so-called KNOW controls) under the Foreign Exchange and Foreign Trade Law, and related politics ministerial ordinance of the law. (Note that the complementary export controls are inapplicable to any application-specific products, except rockets and pilotless aircraft, that are insusceptible to design or program changes.) Accordingly, when exporting or carrying abroad this product, follow the Foreign Exchange and Foreign Trade Control Law and its related regulations with respect to the complementary export controls.
4. The technical information described in this document shows typical characteristics and example application circuits for the products. The release of such information is not to be construed as a warranty of or a grant of license under our or any third party's intellectual property rights or any other rights.
5. The products listed in this document are intended and designed for use as general electronic components in standard applications (office equipment, telecommunication equipment, measuring instruments, consumer electronic products, amusement equipment etc.). Those customers intending to use a product in an application requiring extreme quality and reliability, for example, in a highly specific application where the failure or misoperation of the product could result in human injury or death should first contact us.
 - Aerospace Equipment
 - Equipment Used in the Deep Sea
 - Power Generator Control Equipment (nuclear, steam, hydraulic, etc.)
 - Life Maintenance Medical Equipment
 - Fire Alarms / Intruder Detectors
 - Vehicle Control Equipment (automotive, airplane, railroad, ship, etc.)
 - Various Safety Devices
 - Traffic control system
 - Combustion equipment

In case your company desires to use this product for any applications other than general electronic equipment mentioned above, make sure to contact our company in advance. Note that the important requirements mentioned in this section are not applicable to cases where operation requirements such as application conditions are confirmed by our company in writing after consultation with your company.

6. We are making our continuous effort to improve the quality and reliability of our products, but semiconductor products are likely to fail with certain probability. In order to prevent any injury to persons or damages to property resulting from such failure, customers should be careful enough to incorporate safety measures in their design, such as redundancy feature, fire containment feature and fail-safe feature. We do not assume any liability or responsibility for any loss or damage arising from misuse or inappropriate use of the products.
7. The products have been designed and tested to function within controlled environmental conditions. Do not use products under conditions that deviate from methods or applications specified in this datasheet. Failure to employ the products in the proper applications can lead to deterioration, destruction or failure of the products. We shall not be responsible for any bodily injury, fires or accident, property damage or any consequential damages resulting from misuse or misapplication of the products.
8. **Quality Warranty**
 - 8-1. **Quality Warranty Period**

In the case of a product purchased through an authorized distributor or directly from us, the warranty period for this product shall be one (1) year after delivery to your company. For defective products that occurred during this period, we will take the quality warranty measures described in section 8-2. However, if there is an agreement on the warranty period in the basic transaction agreement, quality assurance agreement, delivery specifications, etc., it shall be followed.
 - 8-2. **Quality Warranty Remedies**

When it has been proved defective due to manufacturing factors as a result of defect analysis by us, we will either deliver a substitute for the defective product or refund the purchase price of the defective product.

Note that such delivery or refund is sole and exclusive remedies to your company for the defective product.
 - 8-3. **Remedies after Quality Warranty Period**

With respect to any defect of this product found after the quality warranty period, the defect will be analyzed by us. On the basis of the defect analysis results, the scope and amounts of damage shall be determined by mutual agreement of both parties. Then we will deal with upper limit in Section 8-2. This provision is not intended to limit any legal rights of your company.
9. Anti-radiation design is not implemented in the products described in this document.
10. The X-ray exposure can influence functions and characteristics of the products. Confirm the product functions and characteristics in the evaluation stage.
11. WLCSP products should be used in light shielded environments. The light exposure can influence functions and characteristics of the products under operation or storage.
12. Warning for handling Gallium and Arsenic (GaAs) products (Applying to GaAs MMIC, Photo Reflector). These products use Gallium (Ga) and Arsenic (As) which are specified as poisonous chemicals by law. For the prevention of a hazard, do not burn, destroy, or process chemically to make them as gas or power. When the product is disposed of, please follow the related regulation and do not mix this with general industrial waste or household waste.
13. Please contact our sales representatives should you have any questions or comments concerning the products or the technical information.



Nisshinbo Micro Devices Inc.

Official website

<https://www.nisshinbo-microdevices.co.jp/en/>

Purchase information

<https://www.nisshinbo-microdevices.co.jp/en/buy/>